

(12) INTERNATIONAL APPLICATION PUBLISHED UNDER THE PATENT COOPERATION TREATY (PCT)

(19) World Intellectual Property Organization
International Bureau



(43) International Publication Date
10 May 2001 (10.05.2001)

PCT

(10) International Publication Number
WO 01/32086 A1

- (51) International Patent Classification⁷: **A61B 17/14**
- (21) International Application Number: PCT/US00/30213
- (22) International Filing Date:
1 November 2000 (01.11.2000)
- (25) Filing Language: English
- (26) Publication Language: English
- (30) Priority Data:
09/432,351 2 November 1999 (02.11.1999) US
- (71) Applicant and
(72) Inventor: **SHRAGA, Steven** [US/US]; 9433 Byron Avenue, Surfside, FL 33154 (US).
- (74) Agents: **MATOS, Peter, A. et al.**; Malloy & Malloy, P.A., 2800 S.W. Third Avenue, Historic Coral Way, Miami, FL 33129 (US).
- (81) Designated States (*national*): AE, AG, AL, AM, AT, AU, AZ, BA, BB, BG, BR, BY, BZ, CA, CH, CN, CR, CU, CZ, DE, DK, DM, DZ, EE, ES, FI, GB, GD, GE, GH, GM, HR, HU, ID, IL, IN, IS, JP, KE, KG, KP, KR, KZ, LC, LK, LR, LS, LT, LU, LV, MA, MD, MG, MK, MN, MW, MX, MZ, NO, NZ, PL, PT, RO, RU, SD, SE, SG, SI, SK, SL, TJ, TM, TR, TT, TZ, UA, UG, UZ, VN, YU, ZA, ZW.
- (84) Designated States (*regional*): ARIPO patent (GH, GM, KE, LS, MW, MZ, SD, SL, SZ, TZ, UG, ZW), Eurasian patent (AM, AZ, BY, KG, KZ, MD, RU, TJ, TM), European patent (AT, BE, CH, CY, DE, DK, ES, FI, FR, GB, GR, IE, IT, LU, MC, NL, PT, SE, TR), OAPI patent (BF, BJ, CF, CG, CI, CM, GA, GN, GW, ML, MR, NE, SN, TD, TG).
- Published:**
— *With international search report.*
- For two-letter codes and other abbreviations, refer to the "Guidance Notes on Codes and Abbreviations" appearing at the beginning of each regular issue of the PCT Gazette.*

(54) Title: A SINGLE USE LANCET ASSEMBLY

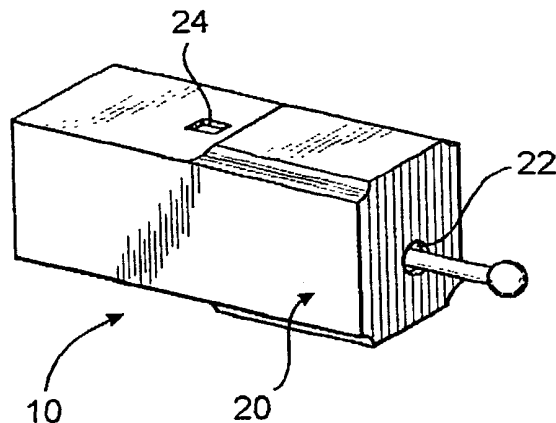

(57) Abstract: A single use lancet device (10) having a housing (20) with an open interior (28), an access opening (22) with a piercing tip (34), a driving assembly (38) structured to move a lancet (30), and a restrictor assembly (60) having a shoulder (62) and a restrictor panel (64).

WO 01/32086 A1



DescriptionA SINGLE USE LANCET ASSEMBLY5 BACKGROUND OF THE INVENTIONField of the Invention

The present invention relates to a single use lancet assembly which is substantially compact, yet effective for piercing a patient's finger or other body part to obtain a blood sample. The
10 single use lancet device is further configured to be substantially safe to transport and to ensure that subsequent uses of a contaminated lancet tip cannot occur.

15 Description of the Related Art

Lancets are commonly utilized instruments which are employed both in hospitals and other medical facilities, as well as by private individuals, such as diabetics, in order to prick or pierce a patient's skin, typically on a finger of a patient,
20 thereby leading to the generation of a blood sample which can be collected for testing. Because of the wide spread use of such lancets, there are a variety of lancet devices which are available for utilization by patients and/or practitioners in a variety of different circumstances.

For example, a typical lancet may merely include a housing with a sharp piercing tip that is pushed into the patient's skin. More commonly, however, lancet devices, which house a piercing tip and/or a lancet, have been developed which effectively encase and fire the lancet into the patient's skin, thereby eliminating the
30 need for the person taking the sample to actually push the lancet tip into the skin.

Within the various types of specialized lancet devices, one variety are typically configured for multiple and/or repeated uses, while another category is particularly configured for single use, after which the entire device is disposed of. Looking in
35 particular to the single use, disposable lancet devices, such devices typically include a housing which contains and directs or

drives a piercing tip into the patient's skin, and which is disposed of along with the used lancet. Naturally, so to make such disposable devices cost effective for frequent use, such devices tend to be rather simplistic in nature providing only a sufficient mechanism for firing, and not overly complicating the design so as to minimize that cost.

While existing single use devices are generally effective for achieving the piercing of the skin required for effective operation, such single use, disposable devices typically do not incorporate a large number of safety features to ensure the safe use and disposal of the device. For example, one primary area of safety which must be addressed with all lancet devices pertains to the purposeful and/or inadvertent reuse of a contaminated lancet. Unfortunately, most currently available single use lancet devices are configured such that after a use thereof has been achieved, it is possible for a patient to re-cock the device, thereby allowing for a subsequent, inappropriate use.

As a result, it would be highly beneficial to provide a single use lancet device which is substantially compact and disposable, can be manufactured in a substantially cost effective manner, and which nevertheless is substantially safe to utilize, affirmatively preventing re-use, once contaminated.

Summary of the Invention

The present invention relates to a single use lancet device configured to pierce a patient's skin and be useable only a single time, thereby preventing reuse of a contaminated lancet piercing tip. In particular, the present single use lancet device includes a housing having an open interior area and an access opening defined therein. The housing is preferably compact and includes a lancet disposed within its open interior.

Looking to the lancet, it is preferably of the type which includes a body and a piercing tip. It is the piercing tip which includes the pointed configuration structured to penetrate or pierce a patient's skin for the drawing of blood. Moreover, the lancet is cooperatively disposed within the open interior of the

housing such that the lancet may move between at least a cocked orientation and a piercing orientation wherein the patient's skin is penetrated by the piercing tip.

Also operatively associated with the lancet is a driving assembly. The driving assembly is structured to move or drive the lancet, at least temporarily, into the piercing orientation from the cocked orientation. Preferably, however, the device is configured such that the cocked orientation is generally maintained until affirmatively released by a user. Along these lines, the present single use lancet device also includes an actuation button operatively associated with the lancet. The actuation button is structured to protrude from the housing, at least when the lancet is disposed in the cocked orientation, so as to be effectively actuatable. When the lancet is in the cocked orientation, the actuation assembly maintains the lancet in that cocked orientation, however, when it is actuated, such as by being pushed inward, the lancet is released from the cocked orientation and the driving assembly propels the lancet at least temporarily into its piercing orientation wherein the piercing tip protrudes through the access opening of the housing.

In order to ensure that lancet device can only be used a single time, the present single use lancet device further includes abutment structure cooperatively disposed between the housing and the lancet. The abutment structure is configured to prevent the lancet from moving into the cocked orientation after movement into the piercing orientation. Preferably, the abutment structure includes a shoulder element and a restrictor panel operatively associated with the lancet and the housing. In particular, the shoulder element is structured to pass over the restrictor panel when the lancet moves from its cocked orientation to its piercing orientation. Conversely, however, when a user attempts to move the lancet back into the cocked orientation after it moved into the piercing orientation, the restrictor panel abuts the shoulder element preventing further movement. As a result, movement of the lancet into the cocked orientation is prevented once the lancet has been used a single time, and subsequent uses of a contaminated

lancet are prevented.

Brief Description of the Drawings

5 For a fuller understanding of the nature of the present invention, reference should be had to the following detailed description taken in connection with the accompanying drawings in which:

Figure 1 is a perspective illustration of an embodiment of the single use lancet device of the present invention;

10 Figure 2 is a side cross section view of the single use lancet device of the present invention in an unused, initially uncocked orientation;

Figure 3 is a side cross section view of the single use lancet device of the present invention in a cocked orientation;

15 Figure 4 is a side cross section view of the single use lancet device of the present invention after it has moved into a piercing orientation from the cocked orientation;

Figure 5 is a front cross section view of the single use lancet device of the present invention; and

20 Figure 6 is a side cross section view of another embodiment of the single use lancet device of the present invention after the lancet has moved from the cocked orientation through the piercing orientation.

25 Like reference numerals refer to like parts throughout the several views of the drawings.

Detailed Description of the Preferred Embodiment

Shown throughout the Figures, the present invention is directed towards a single use lancet device, generally indicated
30 as 10. In particular, the single use lancet device 10 of the present invention includes a housing, generally indicated as 20. The housing 20 is preferably substantially small and compact, and may be made of one or a plurality of segments, preferably of a generally rigid, disposable material, such as plastic. The
35 housing 20 includes an at least partially opened interior 28 and at least one access opening 22 defined therein. The open interior

28 of the housing 20 is preferably sized and configured to effectively receive a lancet, generally 30 therein.

In particular, the lancet device 10 of the present invention also comprises a lancet 30. The lancet 30 preferably includes a body 32 and a piercing tip 34. The piercing tip 34 is what will be used to pierce a person's skin so as to draw blood to be utilized for a sample and or test procedure. Moreover, the body 32 may be the shaft of the piercing tip 34 and/or an additional structure such as that depicted in the figures. Regardless, however, the lancet 30 is structured to move within the open interior 28 of a housing 20, preferably at least between a cocked orientation, as depicted in Figure 3, and a piercing orientation wherein the piercing tip 34 of lancet 30 at least temporarily protrudes through the access opening 22.

Looking in further detail to the illustrated lancet device 10, and the path of movement of the lancet 30 within the housing 20, when the lancet device 10 is initially obtained for use, the lancet 30 is preferably maintained in an un-used, initially un-cocked and pre-fired orientation, as best seen in Figure 2. In this initially un-cocked and pre-fired orientation a protective cover 40 preferably extends into the open interior 28 of the housing 20 so as to at least partially and removably cover the piercing tip 34 of the lancet 30, thereby maintaining the safety and sterility of the piercing tip 34 when not being used. In this regard, the protective cover 40 may be formed from a variety of preferably rigid materials and is structured to protrude from the housing 20. Furthermore, the protective cover 40 may include an enlarged head 42 configured to facilitate grasping thereof.

Preferably utilizing the protective cover 40, the protective cover 40 is structured to be pushed inwardly into the housing by a user, as depicted by the arrows on Figure 2, thereby pushing the lancet 30 further into the housing 20. Such pushing of the lancet 30 into the housing 20 results in a positioning of the lancet 30 in its cocked orientation, best illustrated in Figure 3. Once in the cocked orientation, the protective cover 40 is then structured to be removable from the piercing tip 34, such as by a twisting

thereof, thereby leaving the piercing tip 34 complete exposed for use.

The single use lancet of the present invention further includes a driving assembly, generally 38. The driving assembly 38 is particularly configured to move the lancet 30 at least temporarily into its piercing orientation wherein the piercing tip 34 protrudes through the access opening 22 of the housing 20 a desired amount. In particular, if desired a depth adjustment structure could be positioned at the access opening to control the amount which the piercing tip protrudes from the housing 20. For example, a threaded washer type element could be adjustably secured to the housing 20 in generally surrounding relation to the access opening 22.

Looking further to the driving assembly, preferably the driving movement occurs when the lancet 30 is released from its cocked orientation. In the illustrated embodiment, the driving assembly 38 includes a biasing element operatively disposed between the lancet 30 and the housing 20. Moreover, in the illustrated embodiment a spring is preferably utilized, however, it is recognized that a variety of other driving assemblies can be utilized, including a wedge assembly, a hammer type assembly and/or a resilient material plate, segment or extension, all of which may be configured to move the lancet 30 from the cocked orientation into the piercing orientation. Further, it is preferred that based upon the sizing of the housing 20 and the nature and size of the driving assembly 38, that after the lancet 30 has moved into the piercing orientation wherein the piercing tip 34 protrudes through the access opening 22, the lancet tends to be retracted back into the housing, as best illustrated in Figure 4. As a result, the used piercing tip 34 is effectively concealed within the housing 20 subsequent to usage, protecting against inadvertent engagement between a person and the used piercing tip 34.

In order to retain, and subsequently effectively release the lancet 30 from its cocked orientation, the single use lancet of the present invention further includes an actuation assembly,

generally, 50. Although a variety of different actuation assemblies may be incorporated so as to retain and then release the lancet 30 from its cocked orientation, which in the illustrated embodiment allows the driving assembly to be released from its compressed orientation, the actuation assembly 50 includes an actuation button 52. In the illustrated embodiment, the actuation button 52 is structured to at least temporarily protrude from the housing 20, such as through an actuation aperture 24. Furthermore, the actuation button 52 is preferably secured, either directly or indirectly to the lancet 30, so as to generally restrict movement of the lancet 30 from the cocked orientation when it protrudes from the housing 20. As a result, the cocked orientation is maintained while the actuation button protrudes from the housing 20. Specifically, in the illustrated embodiment, the actuation button 52 extends from the body 32 of the lancet 30 by a biased segment, and as such, by abutting the housing 20 within the actuation opening 24, movement of the lancet 30 from the cocked orientation is prevented. When, however, the actuation button 52 is actuated, such as by being pushed inwardly, into the housing, it is at least temporarily concealed within the housing 20, removing the abutting engagement and allowing the lancet 30 to freely move within the housing 20, at least temporarily into the piercing orientation. Although the preceding defines the illustrated actuation assembly, it is understood that a variety of alternative actuation assemblies, such as including separate elements to retain and to release the lancet may also be provided, and or including structures which are actually part of the driving assembly, may also be provided.

Looking in particular to Figure 5, movement of the lancet 30 through the housing 20 is preferably maintained in a substantially linear path by a guide assembly. In the illustrated embodiment, the guide assembly includes at least one guide ridge 33 protruding from the body 32 of the lancet 30, and at least one corresponding guide track 25 structured to movably receive the guide ridge 33 therein. The guide track 25 preferably extends at least partially along a length of the open interior 28 of the housing 20 so as to

maintain the guide ridge 33 effectively therein during a necessary range of motion of the lancet 30. As depicted in Figure 5, preferably a pair of guide ridges 33 are disposed on opposite sides of the lancet body 32, with a corresponding pair of oppositely disposed guide tracks 25 being defined in the housing. It is of course, however, understood that the guide tracks 25 need not necessarily be directly defined in the housing 20, but may be additional elements secured therein, and conversely the guide track(s) may be defined in or on the lancet body 32, with the guide ridge(s) extending inwardly from the housing 20.

The single use lancet 10 of the present invention further includes a restrictor assembly, generally 60. The restrictor assembly 60 is structured to substantially prevent the lancet 30 from moving back into the cocked orientation of Figure 3 after it has moved, even momentarily, into the piercing orientation wherein a patient's skin may be pierced and the piercing tip 34 become contaminated. In particular, the restrictor assembly 60 is structured such that when the lancet 30 is disposed in the initially un-cocked orientation, as best seen in Figure 2, movement of the lancet 30 back into the cocked orientation can effectively result despite the restrictor assembly 60. After, however, the lancet 30 has moved into its piercing orientation wherein the piercing 34 has protruded through the access opening 22 of the housing 20, the restrictor assembly is configured such that the lancet 30 can no longer be pushed back into the cocked orientation. As a result, a patient, can neither accidentally nor purposefully reuse the single use lance 10 of the present invention after it has been fired.

In the illustrated embodiment, the restrictor assembly 60 includes an abutment structure cooperatively disposed between the housing 20 and the lancet 30. The abutment structure is configured to physically prevent movement of the lancet back into the cocked orientation. Preferably, the abutment structure comprises a shoulder element 62 and a restrictor panel 64 configured to freely pass one another when the lancet 30 moves from the cocked orientation to the piercing orientation, but also

configured to abut one another upon attempted movement of the lancet 30 back into the cocked orientation after it has moved into the piercing orientation. Looking to Figure 4, the illustrated shoulder element 62 includes an at least partially sloped and preferably biased configuration, such as an elongate biased finger that at least partially retracts inward towards the body 32 of the lancet 30 so as to facilitate passage thereof past the restrictor panel 64. In this regard, preferably mating sloped surfaces are provided on the shoulder element 62 and the restrictor panel 64, thereby facilitating the slided passages past one another, and indeed, promoting an at least partial retraction of the shoulder element 62 to further facilitate this passage past one another, upon movement of the lancet 30 in a first direction towards the access opening 22 of the housing 20. The shoulder element 62 is also, however, structured to generally expand after it has passed the restrictor panel 64, such as back into its normal unretracted and/or un-compressed orientation, such that it will abut the restrictor panel 64 upon attempted movement of the lancet 30 in a second direction opposite the access opening 22 of the housing 20.

Although an opposite configuration could be just as effectively utilized, in the illustrated embodiment, the biased finger 62 of the shoulder element extends from the lancet 30, preferably generally toward the piercing tip 34 of the lancet 30., while the restrictor panel 64 protrudes from the housing 20, extending into the open interior 28 of the housing 20. Along these lines, the restrictor panel 64 includes a protruding element preferably with the aforementioned sloped configuration which downwardly slopes away from the piercing tip 34 of the lancet 30 facilitating the aforementioned slided passage past the shoulder element 62.

So as to provide generally secure movement restriction through effective abutment, both the shoulder element 62 and the restrictor panel 64 each preferably include abutment surfaces 63 and 65, respectively. The abutment surfaces 63 and 65 are structured to generally engage and abut one another, as best

illustrated in Figure 4, thereby preventing movement of the lancet 30 back into the cocked orientation. In the illustrated embodiment, the abutment surfaces 63, 65 are generally flat, although it is recognized that interlocking fingers or wedges, and/or other types of engaging structures that prevent relative movement in at least one direction could also be effectively utilized.

Addressing further the restrictor assembly of the present invention, it is understood that a variety of different restrictor assemblies may be effectively utilized which prevent movement of a lancet 30 back into a cocked orientation after the lancet 30 has moved sufficiently forward and/or has moved into the piercing orientation. As such, the embodiment illustrated in Figures 2 through 5 is merely a single illustration of a preferred contemplated embodiment, and other alternative embodiments are also considered within the scope of the restrictor assembly of the present invention. By way of example, and looking specifically to Figure 6, the actuation button 52 itself may comprise part of the restrictor assembly. In such an embodiment, a restrictor panel 25 is defined in the housing 20, and the actuation button 52 as part of the biased finger of the shoulder element, includes an abutment surface 54 which engages a confronting surface of the restrictor panel 25. In such an embodiment, the initially uncocked orientation provides for the actuation button 52 to be initially disposed rearward of the restrictor panel 25 so as to permit movement of the lancet 30 at least initially into the cocked orientation. Moreover, in this embodiment, the previous embodiment, and/or any other alternative embodiment, if desired, the protective cover 40 may be equipped with an interior shield segment or other configuration which extends into the housing and maintains the biased finger of the shoulder element 62, or another component of the restrictor assembly, in a generally compressed and/or retracted orientation until the protective cover 40 is removed. As a result, in such an embodiment, so long as the protective cover 40 is maintained on the piercing tip 34, the lancet 30 is always able to return the cocked orientation.

Preferably, however, re-positioning of the protective cover onto the piercing tip in such a manner as to be able to "reset" the lancet 30, allowing to move once again into the cocked orientation will be prevented.

5 Since many modifications, variations and changes in detail can be made to the described preferred embodiment of the invention, it is intended that all matters in the foregoing description and shown in the accompanying drawings be interpreted as illustrative and not in a limiting sense. Thus, the scope of
10 the invention should be determined by the appended claims and their legal equivalents.

Now that the invention has been described,

Claims

1. A single use lancet device comprising:

a housing, said housing including an at least partially open interior and an access opening defined therein;

5 a lancet, said lancet including a body and a piercing tip;
said lancet disposed in said open interior of said housing and structured to move at least between a cocked orientation and a piercing orientation;

10 a driving assembly structured to move said lancet at least temporarily into said piercing orientation; and

a restrictor assembly structured to substantially prevent said lancet from moving substantially towards and into said cocked orientation after said lancet has moved at least temporarily into said piercing orientation.

15 2. A single use lancet as recited in claim 1 wherein said driving assembly includes a biasing element operatively disposed between said lancet and said housing.

3. A single use lancet as recited in claim 2 wherein said biasing element comprises a spring.

20 4. A single use lancet as recited in claim 1 further comprising an actuation assembly structured to release said lancet from said cocked orientation.

25 5. A single use lancet as recited in claim 4 wherein said actuation assembly comprises a button structured to at least temporarily protrude from said housing when said lancet is disposed in said cocked orientation.

30 6. A single use lancet as recited in claim 5 wherein said button is secured to said lancet and is structured to abut said housing when protruding therethrough so as to retain said lancet in said cocked orientation until disengaged from said abutting engagement.

35 7. A single use lancet as recited in claim 6 wherein said button is structured to be at least temporarily concealed by said housing after said lancet has moved out of said cocked orientation.

8. A single use lancet as recited in claim 1 wherein said

restrictor assembly comprises and abutment structure cooperatively disposed between said housing and said lancet and structured to prevent said lancet from moving into said cocked orientation after movement into said piercing orientation.

5 9. A single use lancet as recited in claim 8 wherein said abutment structure comprises a shoulder element and a restrictor panel, said restrictor panel and said shoulder element structured to pass one another upon said lancet moving from said cocked orientation to said piercing orientation, and to abut one another
10 upon attempted movement of said lancet into said cocked orientation after movement into said piercing orientation.

 10. A single use lancet as recited in claim 9 wherein said shoulder element includes a sloped, at least partially biased configuration structured to at least partially retract to
15 facilitate passage of said restrictor panel and said shoulder element past one another in a first direction corresponding movement of said lancet from said cocked orientation to said piercing orientation, and to expand subsequent said passage past
20 one another in said first direction such that said shoulder element and said restrictor panel abut one another upon movement towards one another in a second direction generally opposite said first direction.

 11. A single use lancet as recited in claim 9 wherein said shoulder element comprises a biased finger extending from said
25 lancet, and said restrictor panel comprises a protruding element protruding from said housing.

 12. A single use lancet as recited in claim 11 wherein said protruding element includes a sloped configuration which
30 downwardly slopes away from said piercing tip of said lancet so as to facilitate passage thereof past said biased finger upon said lancet moving in a first direction towards said access opening.

 13. A single use lancet as recited in claim 12 wherein said biased finger comprises an actuation button structured to release
said lancet from said cocked orientation.

35 14. A single use lancet as recited in claim 1 further comprising a guide assembly operatively disposed between said

lancet and said housing and structured to guide a substantially linear movement of said lancet through said housing.

15. A single use lancet as recited in claim 14 wherein said guide assembly comprises at least one guide ridge protruding from said body of said lancet, and at least one corresponding guide track structured to movably receive said guide ridge therein and extending at least partially along a length of said open interior of said housing.

16. A single use lancet as recited in claim 1 further comprising a protective cover structured to at least partially and removably cover said piercing tip of said lancet at least prior to movement of said lancet into said cocked orientation.

17. A single use lancet as recited in claim 16 wherein said protective cover is structured to protrude from said access opening of said housing and is structured to be pushed by a user so as to position said lancet into said cocked orientation.

18. A single use lancet device comprising:

a housing, said housing including an at least partially open interior and an access opening defined therein;

a lancet, said lancet including a body and a piercing tip; said lancet disposed in said open interior of said housing and structured to move at least between a cocked orientation and a piercing orientation;

a driving assembly structured to move said lancet at least temporarily into said piercing orientation;

a shoulder element and a restrictor panel operatively associated with said lancet and said housing, said shoulder element structured to pass over said restrictor panel upon said lancet moving from said cocked orientation to said piercing orientation, and to abut said restrictor panel upon attempted movement of said lancet into said cocked orientation after movement into said piercing orientation so as to substantially prevent said lancet from moving substantially towards and into said cocked orientation after said lancet has moved at least temporarily into said piercing orientation; and

an actuation button structured to at least temporarily

protrude from said housing when said lancet is disposed in said cocked orientation so as to maintain said lancet in said cocked orientation.

5 19. A single use lancet as recited in claim 18 wherein said shoulder element comprises said actuation button.

20. A single use lancet as recited in claim 18 wherein said shoulder element extends from said lancet and said restrictor panel is at least partially secured to said housing.

10 21. A single use lancet as recited in claim 18 further comprising a protective cover structured to at least partially and removably cover said piercing tip of said lancet at least prior to movement of said lancet into said cocked orientation.

15 22. A single use lancet as recited in claim 21 wherein said protective cover is structured to protrude from said access opening of said housing and is structured to be pushed by a user so as to position said lancet into said cocked orientation.

20 23. A single use lancet as recited in claim 18 wherein said shoulder element comprises a biased finger extending from said lancet generally towards said piercing tip of said lancet, and said restrictor panel comprises a protruding element disposed in said housing.

25 24. A single use lancet as recited in claim 23 wherein said protruding element includes a sloped configuration which downwardly slopes away from said piercing tip of said lancet so as to facilitate passage thereof past said biased finger upon said lancet moving in a first direction towards said access opening.

30 25. A single use lancet as recited in claim 18 further comprising at least one guide ridge protruding from said body of said lancet, and at least one corresponding guide track structured to movably receive said guide ridge therein and extending at least partially along a length of said open interior of said housing so as to guide substantially linear movement of said lancet within said housing.

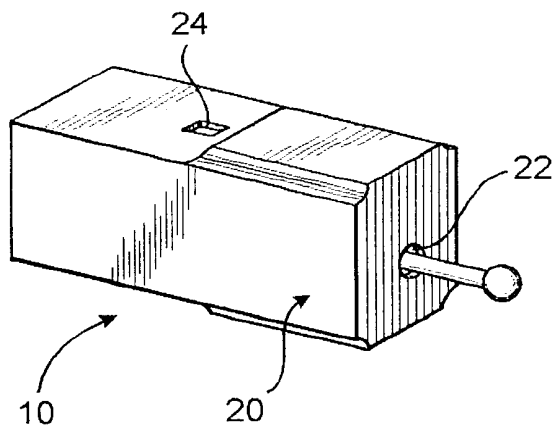

FIG. 1

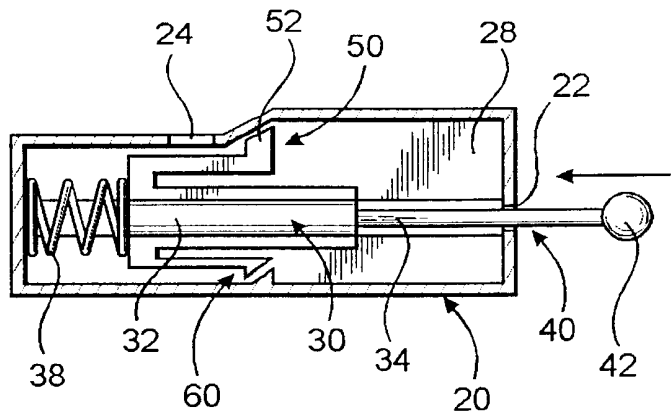

FIG. 2

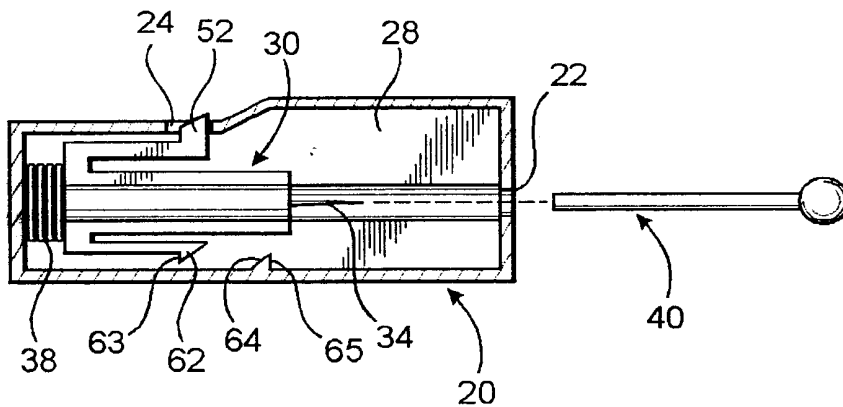

FIG. 3

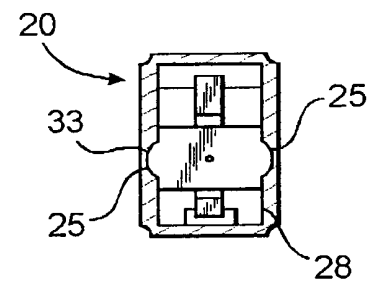

FIG. 5

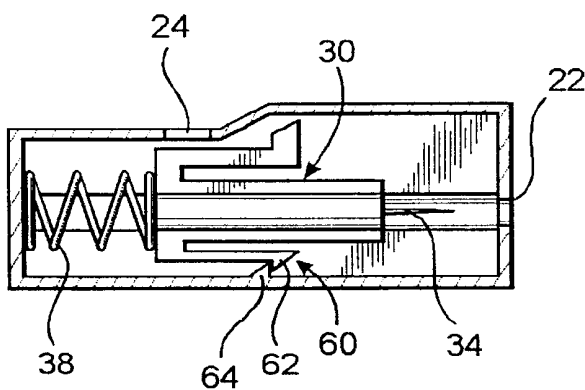

FIG. 4

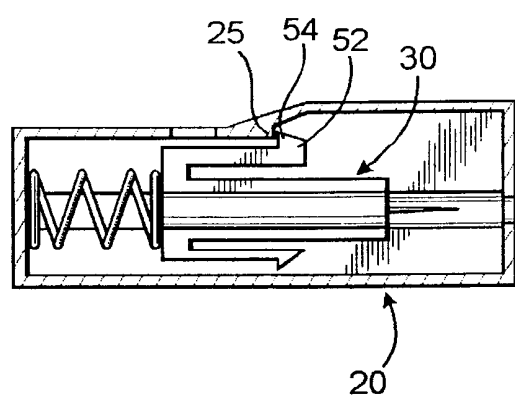

FIG. 6

INTERNATIONAL SEARCH REPORT

International application No.

PCT/US00/30213

A. CLASSIFICATION OF SUBJECT MATTER

IPC(7) : A61B 17/14

US CL : 606/183

According to International Patent Classification (IPC) or to both national classification and IPC

B. FIELDS SEARCHED

Minimum documentation searched (classification system followed by classification symbols)

U.S. : 606/183, 181, 182, 184, 185, 186

Documentation searched other than minimum documentation to the extent that such documents are included in the fields searched

Electronic data base consulted during the international search (name of data base and, where practicable, search terms used)

C. DOCUMENTS CONSIDERED TO BE RELEVANT

Category*	Citation of document, with indication, where appropriate, of the relevant passages	Relevant to claim No.
X	US 5,707,384 (Kim) 13 January 1998 (13/01/98) all	1-25
X	US 5,954,738 (LeVauhn et al.) 21 September 1999, (21/09/99) all	1

Further documents are listed in the continuation of Box C. See patent family annex.

- * Special categories of cited documents:
- *A* document defining the general state of the art which is not considered to be of particular relevance
- *E* earlier document published on or after the international filing date
- *L* document which may throw doubts on priority claim(s) or which is cited to establish the publication date of another citation or other special reason (as specified)
- *O* document referring to an oral disclosure, use, exhibition or other means
- *P* document published prior to the international filing date but later than the priority date claimed
- *T* later document published after the international filing date or priority date and not in conflict with the application but cited to understand the principle or theory underlying the invention
- *X* document of particular relevance; the claimed invention cannot be considered novel or cannot be considered to involve an inventive step when the document is taken alone
- *Y* document of particular relevance; the claimed invention cannot be considered to involve an inventive step when the document is combined with one or more other such documents, such combination being obvious to a person skilled in the art
- *g* document member of the same patent family

Date of the actual completion of the international search 16 JANUARY 2001	Date of mailing of the international search report 25 JAN 2001
--	---

Name and mailing address of the ISA/US Commissioner of Patents and Trademarks Box PCT Washington, D.C. 20231 Facsimile No. (703) 305-3230	Authorized officer Vikki Hoa Trinh <i>(Signature)</i> Telephone No. (703) 308-8238
---	--