

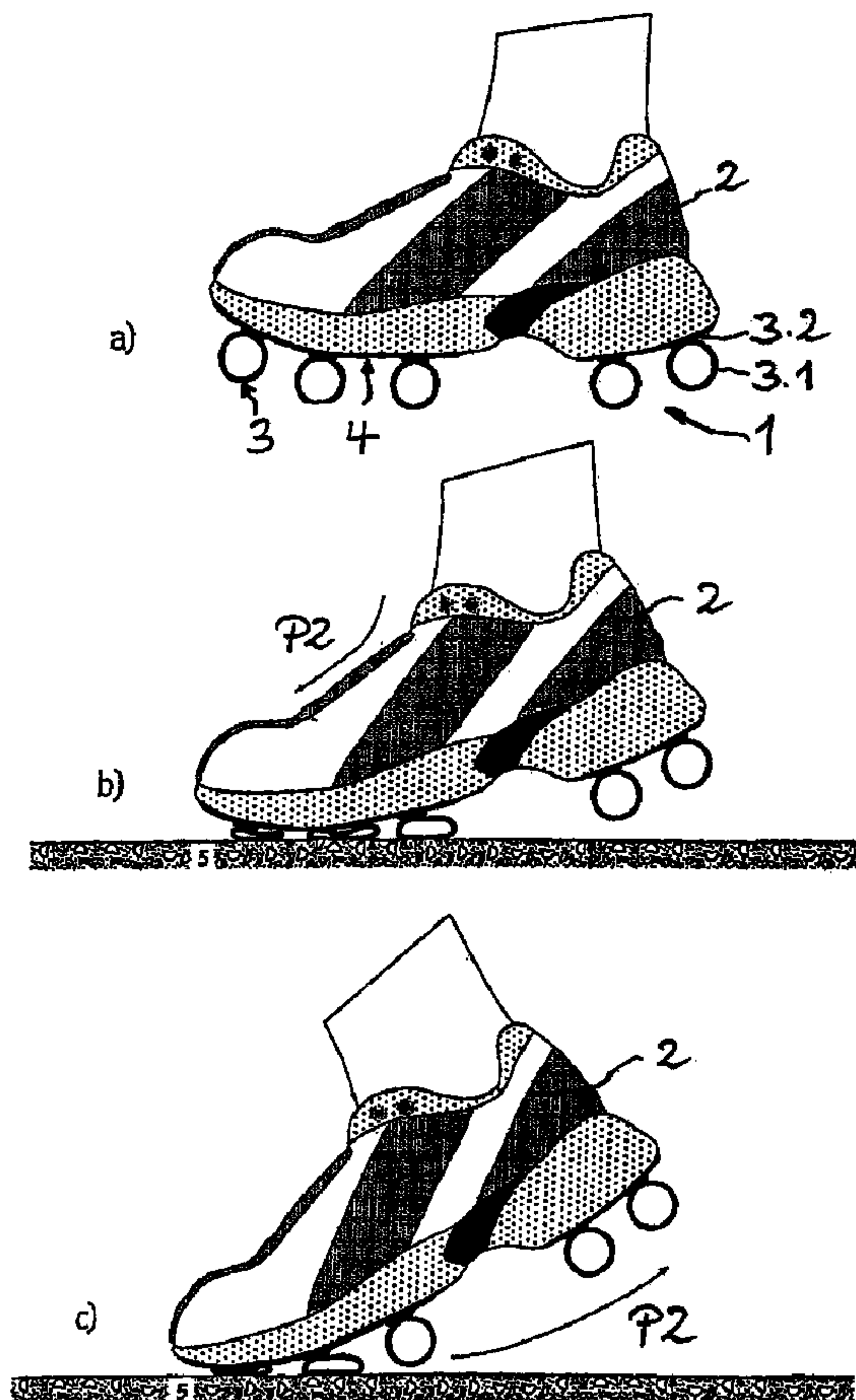

(86) Date de dépôt PCT/PCT Filing Date: 2003/06/05  
 (87) Date publication PCT/PCT Publication Date: 2003/12/18  
 (45) Date de délivrance/Issue Date: 2009/08/11  
 (85) Entrée phase nationale/National Entry: 2004/12/01  
 (86) N° demande PCT/PCT Application No.: CH 2003/000356  
 (87) N° publication PCT/PCT Publication No.: 2003/103430  
 (30) Priorités/Priorities: 2002/06/06 (CH964/02);  
 2003/03/10 (CH369/03)

(51) Cl.Int./Int.Cl. *A43B 13/18* (2006.01),  
*A43B 13/20* (2006.01), *A43B 13/36* (2006.01),  
*A43B 3/24* (2006.01), *A63B 25/10* (2006.01)  
 (72) Inventeur/Inventor:  
 BRAUNSCHWEILER, H. G., CH  
 (73) Propriétaire/Owner:  
 GLIDE'N LOCK GMBH, CH  
 (74) Agent: SIM & MCBURNEY

(54) Titre : SEMELLE D'USURE  
 (54) Title: OUTSOLE



(57) Abrégé/Abstract:

An outsole (1, 3), in particular, for athletic shoes (2) can be realized with a significant elastic deformability in the tangential direction so as to also achieve a superior shock-absorption when the foot contacts the ground obliquely and with a slight propulsive force.

**(57) Abrégé(suite)/Abstract(continued):**

According to the invention, the sole (1) essentially is only rigid to a tangential deformation beyond at least one critical point of deformation in the region that is deformed to this critical point. This results in a correspondingly increased stability for the runner in the respective point of contact or load application. The runner is also able to push off from the point of load application without any loss in distance. A floating effect on the sole is prevented. The sole can be affixed, as a whole or in a plurality of parts, also detachably to an intermediate sole (4) of the shoe (2).

S10083

ABSTRACT

An outsole (1, 3), in particular, for athletic shoes (2) can be realized with a significant elastic deformability in the tangential direction so as to also achieve a superior shock-absorption when the foot contacts the ground obliquely and with a slight propulsive force. According to the invention, the sole (1) essentially is only rigid to a tangential deformation beyond at least one critical point of deformation in the region that is deformed to this critical point. This results in a correspondingly increased stability for the runner in the respective point of contact or load application. The runner is also able to push off from the point of load application without any loss in distance. A floating effect on the sole is prevented. The sole can be affixed, as a whole or in a plurality of parts, also detachably to an intermediate sole (4) of the shoe (2).

(Figure 1).

S10083

OUTSOLETECHNICAL FIELD

The present invention pertains to an outsole, in particular, for athletic shoes which can also be elastically deformed in the tangential direction.

In this context, the term deformation in the tangential direction refers to a deformation in the direction tangential or parallel to the plane of the outsole or its outer surface which, for example, is caused by shearing. Such a deformation differs from a deformation in the direction perpendicular to the plane of the outsole or its outer surface which, for example, is caused by compression. On a horizontal surface, the tangential direction approximately coincides with the horizontal direction, and the perpendicular direction approximately coincides with the vertical direction.

STATE OF THE ART

Outsoles with elastically resilient outsoles are known in numerous variations, wherein different elastic materials of various hardnesses are used. There also exist outsoles with embedded air or gel cushions. These cushions are intended to elastically absorb the shocks that occur while running and to thusly protect, in particular, the joints of the runner while simultaneously providing a comfortable running experience.

Most athletic shoes currently available on the market have spring characteristics that primary provide a spring effect in the vertical direction or in the direction perpendicular to the running surface, namely in the form of a compression of the sole. However, these outsoles are relatively rigid in the horizontal or tangential direction and do not yield

sufficiently if the runner's foot contacts the ground obliquely and with a slight propulsive force. This rigidity in the horizontal or tangential direction is required because a more significant deformability of the sole in the horizontal direction would inevitably result in a floating effect. This would negatively influence the stability of the runner. In addition, the runner would lose at least a certain distance with each step because the sole would initially have to slightly deform in the respectively opposite direction when the runner pushes off in the running direction. Naturally, this floating effect can already be observed in known athletic shoes to a certain degree.

#### EXPLANATION OF THE INVENTION

The present invention is based on the objective of disclosing an outsole with a simple design which makes it possible to eliminate the above-described floating effect and can also be realized sufficiently soft and resilient in the tangential direction.

This objective is attained with an outsole that can also be deformed in the tangential direction and is characterized by the fact that it essentially is only rigid to a tangential deformation beyond at least one critical point of deformation in the region that is deformed to this critical point.

If the at least one critical point of deformation and the load exerted upon the outsole required to reach this critical point of deformation are suitably chosen by adjusting the hardness or resilience of the outsole accordingly, the sole according to the invention can be realized such that it is also soft and resilient tangentially over a broad range of deformation, and that the critical point of deformation is only reached to a

locally limited degree while running, namely in the zone of the sole that is subjected to the maximum load, and only around the time at which this maximum load occurs.

This not only results in a sufficient shock absorption if the runner's foot contacts the ground obliquely and/or with a slight propulsive force, but also in a superior stability at the respective point of impact or load application, from which the runner is able to directly push off again without any loss in distance. The previously described floating effect is prevented in this fashion.

It goes without saying that the critical point of deformation, at which the tangential deformability of the sole according to the invention is terminated, depends on the type of deformation. The deformation does not necessarily have to occur exclusively in the tangential direction. A critical deformation can also be reached during a purely perpendicular or vertical deformation.

According to one preferred embodiment of the invention, the critical point of deformation is only reached after a tangential and/or perpendicular deformation path that is greater than 20 % of the deformable thickness of the sole, if applicable, even greater than 50 % of this thickness. The absolute deformation value may easily reach a few cm.

With respect to constructive considerations and the materials used, the outsole according to the invention may, in principle, be realized in different ways. Various embodiments are described below with reference to the figures. The following description only pertains to those embodiments in which, for example, two layers of the sole are separated, in particular, by an elastically deformable element, and in which the deformable element has a sufficient deformability and makes it possible to achieve a frictional, non-positive and/or positive engagement between

the two layers, namely while essentially preventing the two layers from being displaced parallel to one another.

In a further development of the invention, the sole can be provided with means for detachable fixing to an intermediate sole of a shoe. If the sole is executed as multi-part in this case, the individual parts can be attached independently of one another and/or, e.g. in the event of wear, can be individually exchanged. In this situation, differently constructed parts could also be made available and/or individual designs could be produced which are especially adapted to the respective needs and the running style of the individual runner.

In accordance with an aspect of the present invention, there is provided an outsole for athletic shoes, comprising an elastic deformability also in the tangential direction so that a sufficient cushioning effect is achieved even if the tread of the foot is inclined and somewhat slipping, wherein the outsole encompasses two layers, which are separated by means of at least one elastically deformable element, wherein the element, in response to reaching a critical point deformation, enables a mutual frictionally engaged, non-positive or positive contact of the two layers and a prevention of a parallel displaceability of the two layers so that a secure footing on the region, which is deformed to such an extent, is given.

In accordance with an aspect of the present invention, there is provided an outsole for athletic shoes, wherein the outsole is elastically deformable in the tangential direction so that a sufficient cushioning effect is achieved even if the tread of the foot is inclined and somewhat slipping, wherein the outsole comprises two layers, which are separated by means of at least one elastically deformable element, wherein the element, in response to reaching a critical point deformation, enables a mutual frictionally engaged, non-positive or positive contact of

the two layers and a prevention of a parallel displaceability of the two layers so that a secure footing on the region, which is deformed to such an extent, is given.

BRIEF EXPLANATION OF THE FIGURES

The invention is described in greater detail below with reference to embodiments that are illustrated in the figures. The figures show:

Figure 1, a side view of an athletic shoe with an outsole according to a first embodiment of the invention, namely a) while not being subjected to a load, b) while being subjected to a transversely forward load and c) while pushing off;

Figure 2, a rear view of the athletic shoe shown in Figure 1, namely a) while not being subjected to a load and b) while being subjected to a laterally oblique load;

Figure 3, detailed representations of the hollow elements of the outsole shown in Figure 1, namely a) while not being subjected to a load, b) while being subjected to transversely forward load and c) while being subjected to a vertical load;

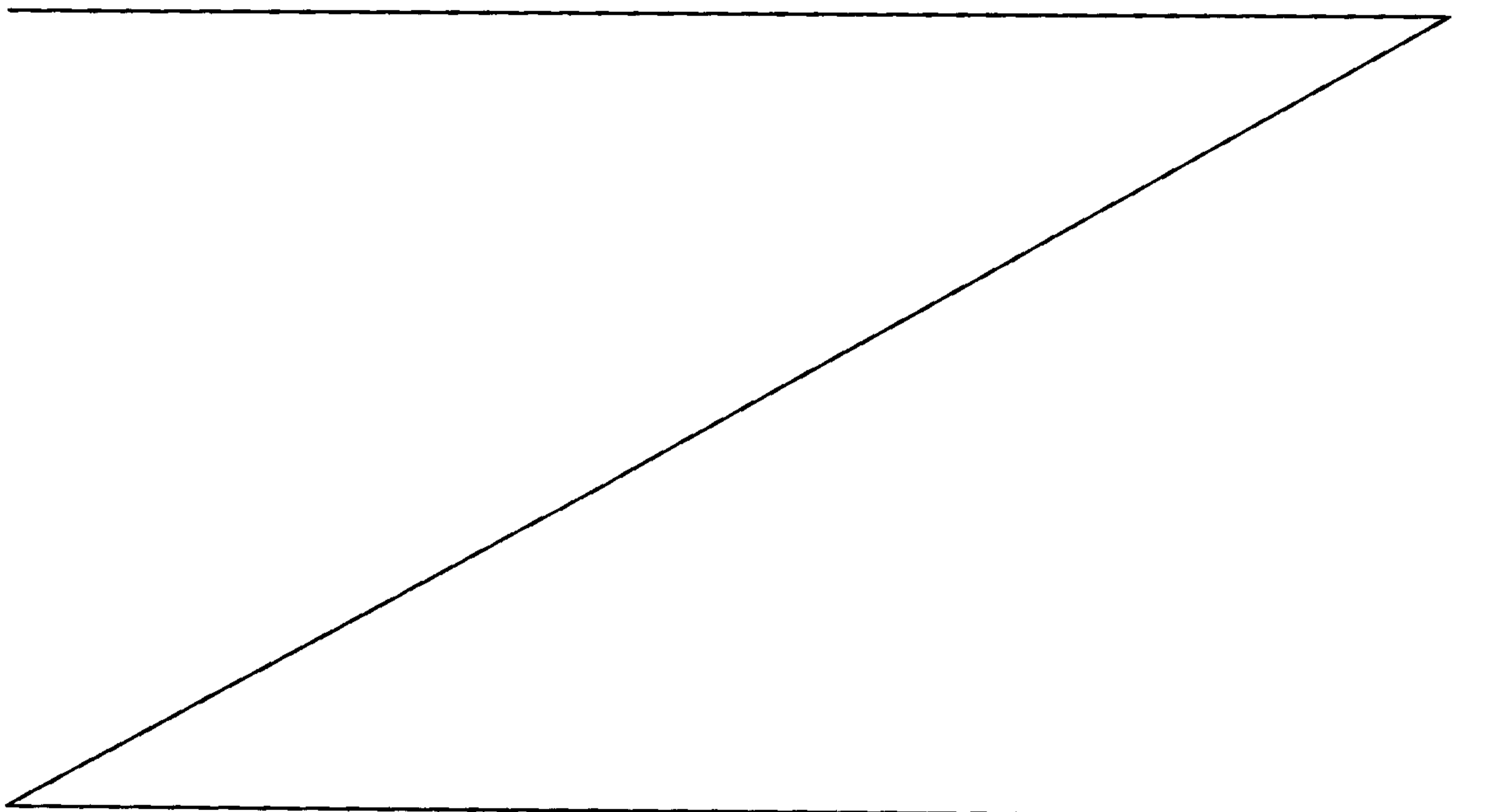



Figure 4, a side view of another embodiment of an outsole according to the invention which comprises tubular hollow elements between the two layers, namely a) while not being subjected to a load and b) while being subjected to a transversely forward load;

Figure 5, a side view of an embodiment of an outsole according to the invention which is divided into a ball section and a heel section and comprises two layers that are connected to one another by means of deformable webs, namely a) while not being subjected to a load and b) while being subjected to a transversely forward load;

Figure 6, an outsole according to the invention with an enclosed volume that is filled with a medium,

Figure 7, a partially sectioned representation of a further outsole according to the invention which is provided with a tothing;

Figure 8, the sports shoe from Fig. 1, wherein according to a further development of the invention, parts of the outsole are or can be detachably affixed to an intermediate sole;

Figure 9, the sports shoe from Fig. 8 viewed from behind under a) and b) with various numbers of detachably attached sole portions adjacent to one another;

Figure 10, a hollow element for an outsole according to the invention somewhat modified compared with the hollow elements from Fig. 3;

Figure 11, a further embodiment of an individual sole element for an outsole according to the invention.

EMBODIMENTS OF THE INVENTION

One embodiment of the invention is initially described below with reference to Figure 1. Although this embodiment does not necessarily represent the most preferred embodiment of the invention, it suffices for explaining the essential characteristics of the invention.

Figure 1 shows a running shoe 2 that is equipped with an outsole 1 according to the invention. The outsole 1 is formed by a plurality of profile-like hollow elements 3 that contain tubular parts 3.1 and are fixed to the underside of an intermediate sole 4 of the running shoe 1 with webs 3.2 that are integrally formed thereon, e.g., by means of bonding. The hollow elements 3 are, for example, manufactured from a rubber material that is able to at least partially deform in an elastic fashion under the loads that occur while running. The material preferably has a high static friction with respect to other materials, but also with respect to itself. Several hollow elements 3 are arranged behind one another in the longitudinal direction of the running shoe 2, wherein a gap remains in the region between the ball and the heel. The hollow elements 3 may respectively extend over the entire width of the running shoe 2. However, it would also be conceivable to arrange two or more hollow elements 3 laterally adjacent to one another as shown in Figure 2.

For example, if the running shoe 2 is subjected to a transversely forward load when it contacts the ground as illustrated by the arrow P1 in Figure 1 b), the tubular parts 3.1 are, if their dimensions are chosen accordingly, completely compressed after an initial elastic absorption of the load in the form of a vertical and horizontal deformation. This leads to a frictional engagement between their upper shell 3.1.1 and their lower shell 3.1.2 (see Figure 3). This frictional engagement generates such a high

resistance to an additional deformation of the tubular parts 3.1 that they practically can only be additionally deformed by the remaining elasticity of the material, i.e., to a negligible degree. In this position and in this state of the outsole 1, the runner is in contact with the ground 5 in such a way that a horizontal shift practically can no longer take place. This means that the runner has a superior stability.

In addition, the runner is able to push off from the position shown in Figure 2 for the next step as illustrated in Figure 1 c) without any loss in distance, namely because the previously described frictional engagement between the tubular parts 3.1 practically makes it impossible for these parts to horizontally deform to a noteworthy degree in the direction of the load that occurs while pushing off and is indicated by the arrow P2. Naturally, one prerequisite for this is that the load exerted upon the deformed region of the sole is maintained between the time at which the foot contacts the ground and the time at which the runner pushes off again. However, this is usually the case when running normally.

Figure 2 shows the running shoe 2 according to Figure 1 in the form of a rear view, namely while a) not being subjected to a load and b) while being subjected to a laterally oblique load. In this case, a compression of the tubular parts 3.1 of the hollow elements 3 can also take place such that a frictional engagement between their upper shells 3.1.1 and their lower shells 3.1.2 is produced. This means that the runner wearing the running shoe 2 is in contact with the ground 5 in such a way that a practically unyielding lateral stability is achieved.

The previously described embodiment is characterized by extremely long deformation paths. Between the state shown in Figure 1 a) in which no load is exerted upon the outsole

and the state shown in Figure 1 b) in which the frictional engagement occurs, these deformation paths may easily amount to more than 20 %, if applicable, even more than 50 %. The shoe shown in Figures 1 and 2 causes the runner to "float on clouds," but the runner never has an unstable sensation and is always directly and solidly in contact with the ground.

Figure 3 shows a detailed representation of the hollow elements 3 according to Figure 1, namely while a) not being subjected to a load and b) while being subjected to a tangential load. A deformation under a vertically downward acting load is shown in part c) of this figure. This part elucidates how the previously described advantages with respect to the stability of the runner and the ability of the runner to push off without any loss in distance are also achieved under a purely vertical load.

The outsole 6 shown in Figure 4 also comprises tubular hollow elements 6.1 that, for example, consist of a rubber material. However, the hollow elements are arranged between an upper layer 6.2 and a lower layer 6.3 in this case and rigidly connected to the respective layers. The two layers 6.2 and 6.3 extend over the entire surface of the outsole. The upper layer 6.2 may, in principle, be formed by a layer that is provided anyhow or by an intermediate layer of the shoe. The lower layer 6.3 could also be provided with a profile. The function of the outsole 6 that is shown in Figure 4 while a) not being subjected to a load basically is identical to that of the outsole 1 described above with reference to Figure 2. When the tubular hollow elements 6.1 are compressed, a frictional engagement between their upper shell and their lower shell is, in particular, also produced in this case as shown in part b) of Figure 4. The deformation of the hollow elements 6.1 under a load is, however, distributed over a larger area due to the thrust effect exerted by the lower layer 6.3.

In the embodiment shown in Figure 5, two separate parts 7.1 and 7.2 are respectively provided for the ball region and the heel region of the outsole 7. It would, in principle, also be conceivable to realize such a separate design in the other discussed embodiments. In addition, simple webs 7.1.3 and 7.2.3 that can be elastically deformed are arranged between the respective upper layers 7.1.1 and 7.2.1 and the respective lower layers 7.1.2 and 7.2.2. Under a load, these webs lie flatly between the two outer layers as, for example, illustrated in part b) of Figure 5. If a material with a high coefficient of friction is used for the outer layers and the webs, a frictional engagement similar to that described above is produced in the situation shown in Figure 5 b). This means that the upper and the lower layers take over part of the function of the above-described upper and lower shells of the tubular parts shown in Figure 1. The function of the webs, in contrast, is approximately identical to that of the flanks of the tubular parts. Two such flanks that are arranged opposite of one another are identified by the reference symbols 3.1.3 and 3.1.4 in Figure 3.

In the outsole 8 shown in Figure 6, no elastic elements are provided between an upper layer 8.1 and a lower layer 8.2. The upper and the lower layer are connected by peripheral side elements 8.3 such that a closed volume 8.4 is formed. This closed volume is filled with a fluid, in particular, a gas such as air or, for example, a gel. In this case, it is important that the outsole can be deformed under the loads that occur while running to such a degree that, as shown in part b), the upper layer 8.1 and the lower layer 8.2 can contact one another in the region subjected to the load. A frictional engagement with the above-described properties is also produced in this case if a material with a high coefficient of friction is chosen for both layers.

If an incompressible gel is used as the medium for filling the volume 8.4, the entire volume or parts thereof need to be elastically expandable in order to achieve the desired effect. If the volume 8.4 is filled with a gas, it would be possible to provide an additional valve 8.5, e.g., in the heel region. The elastic properties and the resilience of the outsole could then be changed by varying the gas pressure in order to adapt the outsole to, for example, the weight or the running characteristics of a specific runner.

Instead of producing a frictional engagement as in the previously described embodiments, it would be possible to alternatively or additionally produce a positive engagement as shown in the partially illustrated outsole 9 according to Figure 7. In this case, a tothing is, for example, arranged between an upper layer 9.1 and a lower layer 9.2.

According to a further development of the invention, the sole can be provided with means which allow it to be detachably affixed to an intermediate sole of the shoe. The sole can in this case be detachably affixed as a whole, in parts or also merely with reference to individual parts. Figure 8 shows a running shoe 2 in which the entire sole 1, but in individual parts, is detachably affixed to an intermediate sole 4 of the running shoe 2. In this case, as in the example from Fig. 1, the sole 1 is formed by a plurality of profile-shaped hollow elements 3 which have tubular sections 3.1 and are detachably affixed to the underside of the intermediate sole 4 with moulded-on webs 3.2 or are only provided for detachable affixing to the underside of the intermediate sole 4 with reference to the hollow elements arranged in the ball area. As can be clearly seen from the enlarged section A in Fig. 8, a so-called hook and loop fastener 10 which can be made many times and can be detached again, is used as the fixing means, wherein the webs 3.2 of the hollow elements 3 are provided with the layer 10.1 of the hook and loop fastener

which is constructed as hook-shaped. Accordingly, the intermediate sole 4 is provided with the complementary layer 10.2 of the hook and loop fastener 10, i.e., constructed as loop-shaped, preferably over the entire area. The two layers of the hook and loop fastener can each be fixedly glued to the hollow elements on the one hand and to the intermediate sole on the other hand.

The detachable fixing has the advantage that if necessary, the sole according to the invention can only be attached to the intermediate sole as required, e.g. directly before and for a training run and the shoe can otherwise also be used without this sole. This particularly makes sense when the sole according to the invention is provided to achieve long spring deflections, e.g. with relatively voluminous hollow elements. In order to protect the intermediate sole and the loop layer of the hook and loop fastener preferably attached thereto, in this case an alternatively attachable protective layer could also be provided per hook and loop fastener, which however is not shown here.

The detachable fixing on the other hand has the advantage that a worn sole can be replaced with a new one. In the case of a multi-part construction of the sole as in the example from Fig. 8 individual parts could also be exchanged whereby, for example, non-uniform wear of the sole caused by the individual running style of each runner could also be taken into account. In this case, however, each runner could make up his own sole with optimum shock-absorbing properties for him, for example, by a special arrangement of the individual parts. As an example of this, Fig. 9 shows the running shoe from Fig. 8 in two views from behind wherein under a) and b) respectively two and three rows of hollow elements 3 are arranged adjacent to one another in the heel area. For an individual shaping of the sole according to the invention, however, differently constructed parts with different properties

could be made available by the manufacturer. As an example of this, Fig. 8 shows a hollow element 3' arranged in the main loading area of the sole, which is provided with a greater wall thickness and as a result, for example, is somewhat more rigid with respect to deformation than the remaining hollow elements.

Figure 10 also shows a hollow element 3" somewhat modified compared with the hollow elements from Fig. 3 for an outsole according to the invention, wherein this hollow element 3" is provided with a flat base surface. In addition, the wall thickness of the element is not constructed as the same throughout. It has been shown that with the form shown, an even better feeling of standing and an improved push-off from the point of contact can be achieved.

Finally, Fig. 11 shows a schematic diagram of a further embodiment of an individual sole element 11 for an outsole according to the invention which has a vertically oriented tubular section instead of a horizontal one.

With respect to the previously described embodiments, it should be noted that individual elements or characteristics thereof may, if applicable, also be utilized in combination with other embodiments. This applies, for example, to the division of the outsole into a ball section and a heel section, as well as to the arrangement of a profile. Frictional engagement means and positive engagement means may be utilized individually or in combination. The embodiments shown in Figures 4 or 5 could be combined with the embodiment shown in Figure 6, wherein an elastic and/or shock-absorbing medium or fluid would be introduced into corresponding hollow spaces in the embodiments according to Figure 4 or 5. Vice versa, mechanical spring elements or shock-absorption elements could be additionally provided in Figure 6. In the further development of the invention in



which the sole according to the invention can be detachably affixed as a whole or at least parts thereof, to an intermediate sole, instead of a hook and loop fastener with a hook-shaped layer and a loop-shaped or felt-like layer, a hook and loop fastener with two hook-shaped layers adapted to one another can also be used wherein such a hook and loop fastener has a higher adhesive force. The detachable connection could alternatively or additionally also be made using a special, re-detachable adhesive.

## LIST OF REFERENCE SYMBOLS

1	Outsole
2	Running shoe
3,3',3"	Hollow elements
3.1	Tubular parts of the hollow elements 3
3.2	Webs of the hollow elements 3
3.1.1	Upper shell of the tubular parts 3.1
3.1.2	Lower shell of the tubular parts 3.1
3.1.3, 4.1.4	Flanks of the tubular parts 3.1
4	Intermediate sole
5	Ground
6	Outsole
6.1	Tubular hollow elements of the outsole 6
6.2	Upper layer of the outsole 6
6.3	Lower layer of the outsole 6
7	Outsole
7.1	Ball section of the outsole 7
7.2	Heel section of the outsole 7
7.1.1, 7.2.1	Upper layer of the outsole sections 7.1 and 7.2
7.1.2, 7.2.2	Lower layer of the outsole sections 7.1 and 7.2
7.1.3, 7.2.3	Deformable webs
8	Outsole
8.1	Upper layer of the outsole 8
8.2	Lower layer of the outsole 8
8.3	Peripheral side parts of the outsole 8
8.4	Volume of the outsole 8
8.5	Valve on the outsole 8
9	Outsole
9.1	Upper layer of the outsole 9
9.2	Lower layer of the outsole 9
10	Hook and loop fastener
10.1	Hook-shaped layer of the hook and loop fastener 10

- 10.12 Loop-shaped layer of the hook and loop fastener 10
- 11 Sole element with vertical tube
- P1 Arrow indicating the load when contacting the ground
- P2 Arrow indicating the load when pushing off

CLAIMS

1. An outsole for athletic shoes, wherein the outsole is elastically deformable in the tangential direction so that a sufficient cushioning effect is achieved even if the tread of the foot is inclined and somewhat slipping, wherein the outsole comprises two layers, which are separated by means of at least one elastically deformable element, wherein the element, in response to reaching a critical point deformation, enables a mutual frictionally engaged, non-positive or positive contact of the two layers and a prevention of a parallel displaceability of the two layers so that a secure footing on the region, which is deformed to such an extent, is given.
2. The outsole according to claim 1, wherein the critical point deformation is only reached after a tangential and/or vertical deformation that is greater than 20% of the deformable thickness of the outsole.
3. The outsole according to claim 1, wherein the critical point deformation is reached only after a tangential and/or vertical deformation that is greater than 50% of the deformable thickness of the outsole.
4. The outsole according to any one of claims 1-3, wherein the outsole is provided with at least one elastically deformable hollow element that contains one or more hollow spaces.
5. The outsole according to claim 4, wherein the hollow element comprises a deformable tubular section.
6. The outsole according to claim 4 or 5, wherein several hollow elements are arranged behind one another in the longitudinal direction of the outsole.

7. The outsole according to claim 4, wherein the hollow element contains two outer layers that are connected to one another by deformable webs such that several hollow spaces are formed.
8. The outsole according to claim 4, wherein the hollow element contains at least one chamber that is filled with a fluid.
9. The outsole according to claim 8, wherein the hollow element contains at least one air-filled chamber that is elastically deformable by compressing the air contained therein.
10. The outsole according to claim 9, wherein the air-filled into the chamber is subjected to a higher pressure than the atmospheric pressure.
11. The outsole according to any one of claims 1 to 10, wherein said outsole is provided with means for detachable fixing to an intermediate sole of a shoe.
12. The outsole according to claim 11, wherein said outsole is constructed as multi-part and wherein the individual parts are detachably attachable as desired at different points locations or in different designs to the intermediate sole.
13. The outsole according to any one of claims 11 or 12, wherein it is constructed as multi-part and that at least two of its parts have a different shaping or elasticity.
14. The outsole according to any one of claims 11 to 13, wherein the means for detachable fixing comprise a part of a hook and loop fastener and wherein the intermediate

sole is provided with the complementary part of this hook and loop fastener.

15. The outsole according to claim 14, wherein the means comprise a part of the hook and loop fastener provided with hooks.

1/6

Fig 1a)

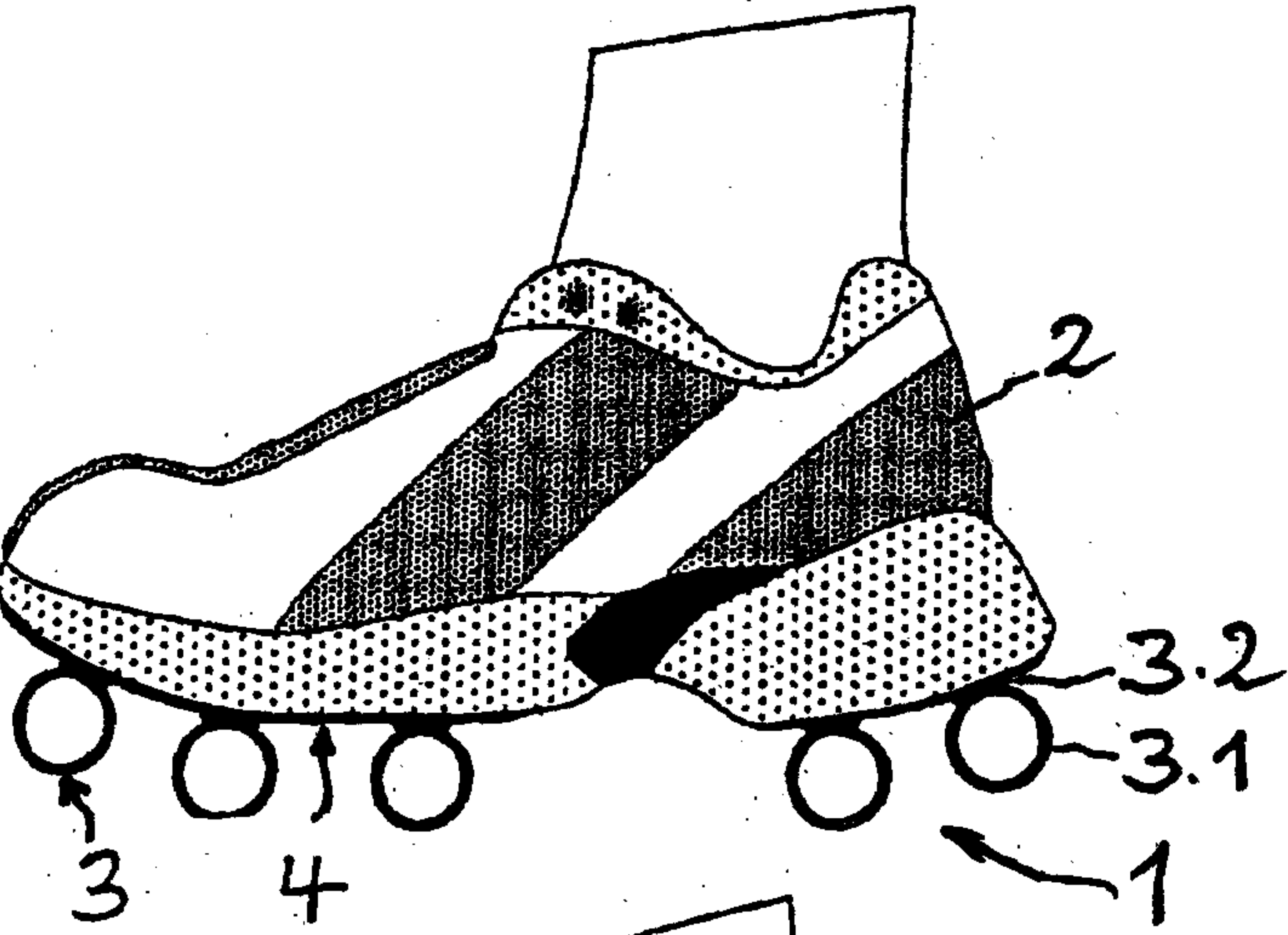

Fig 1b)

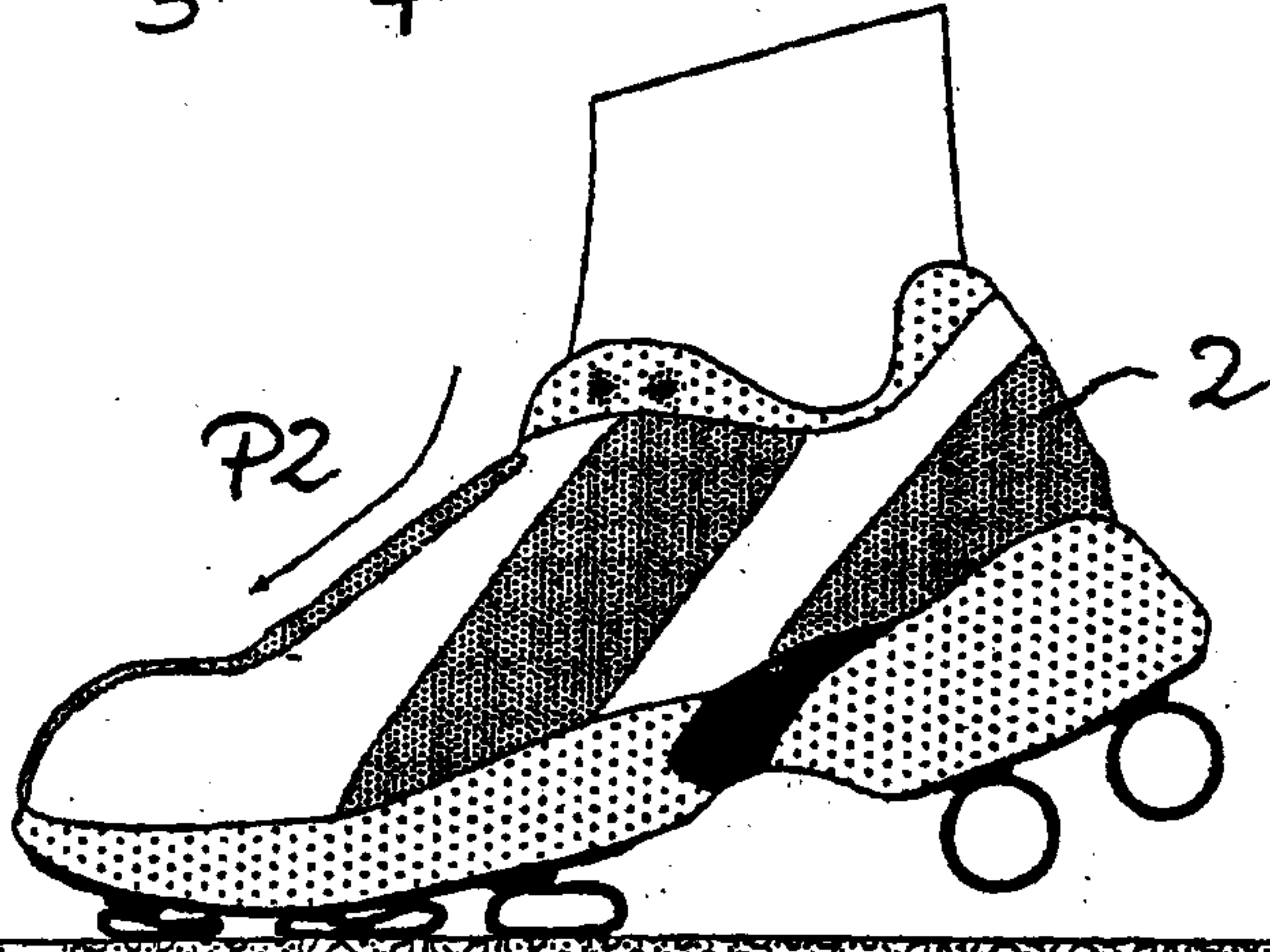
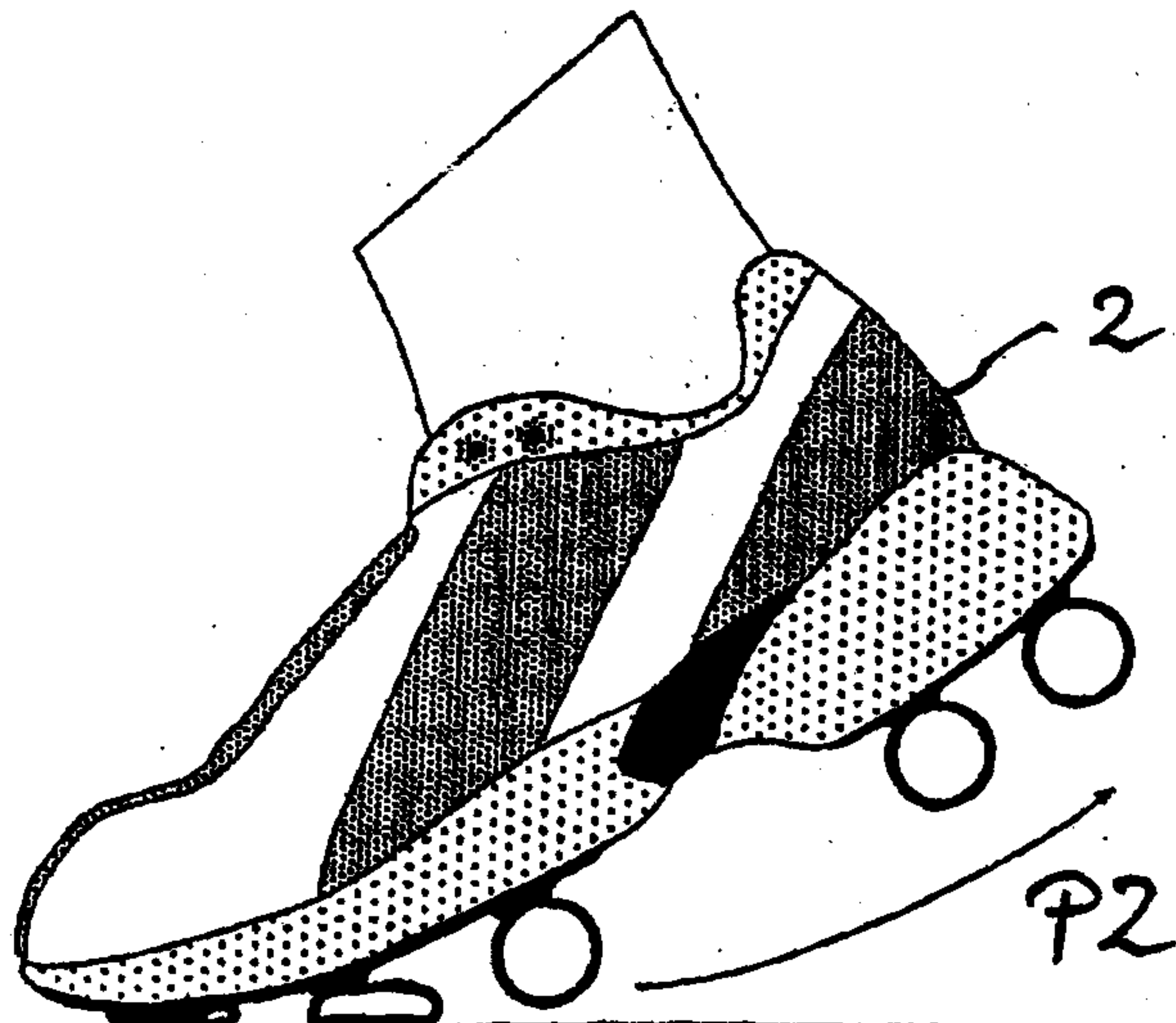

Fig 1c)



2/6

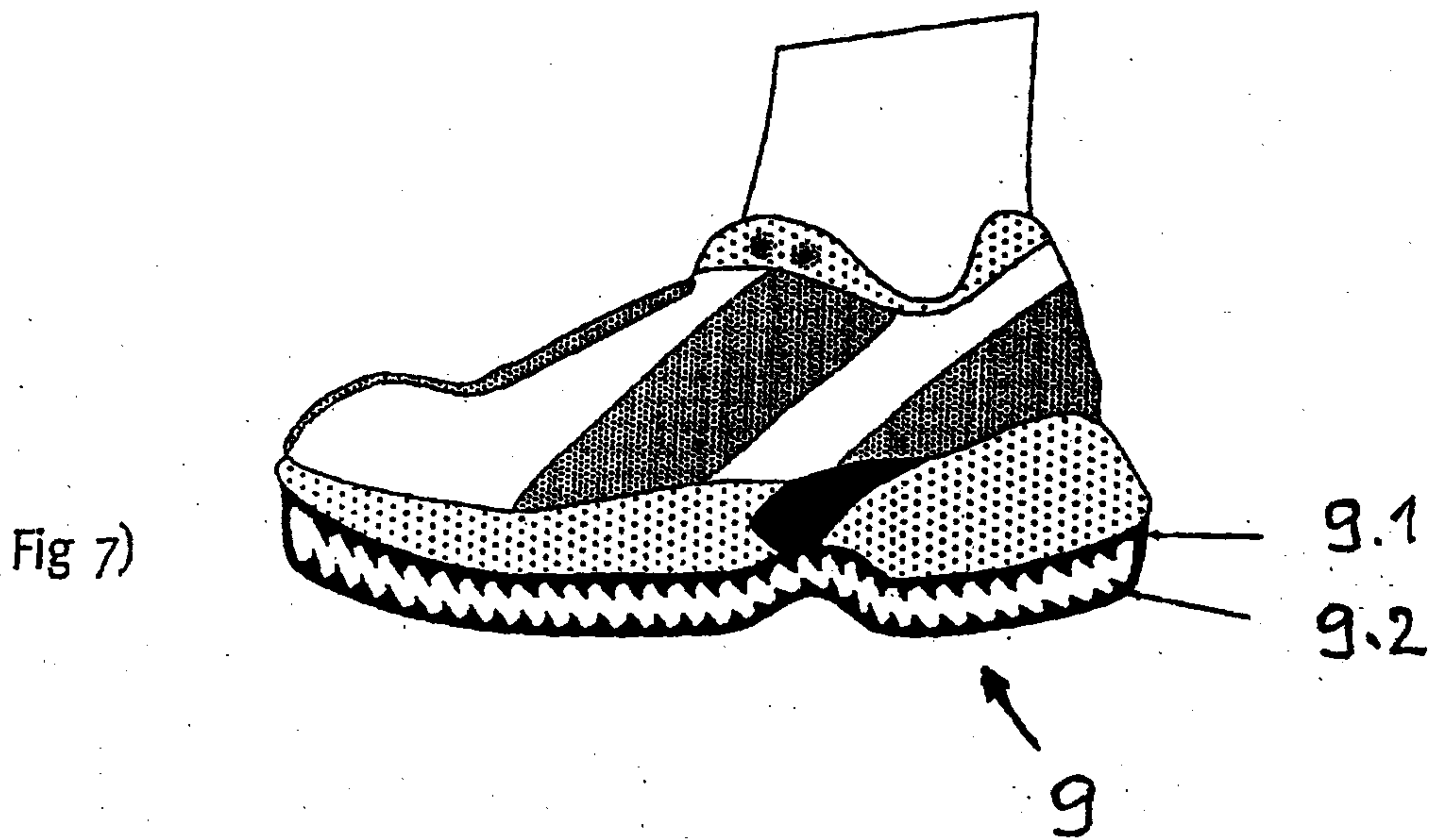
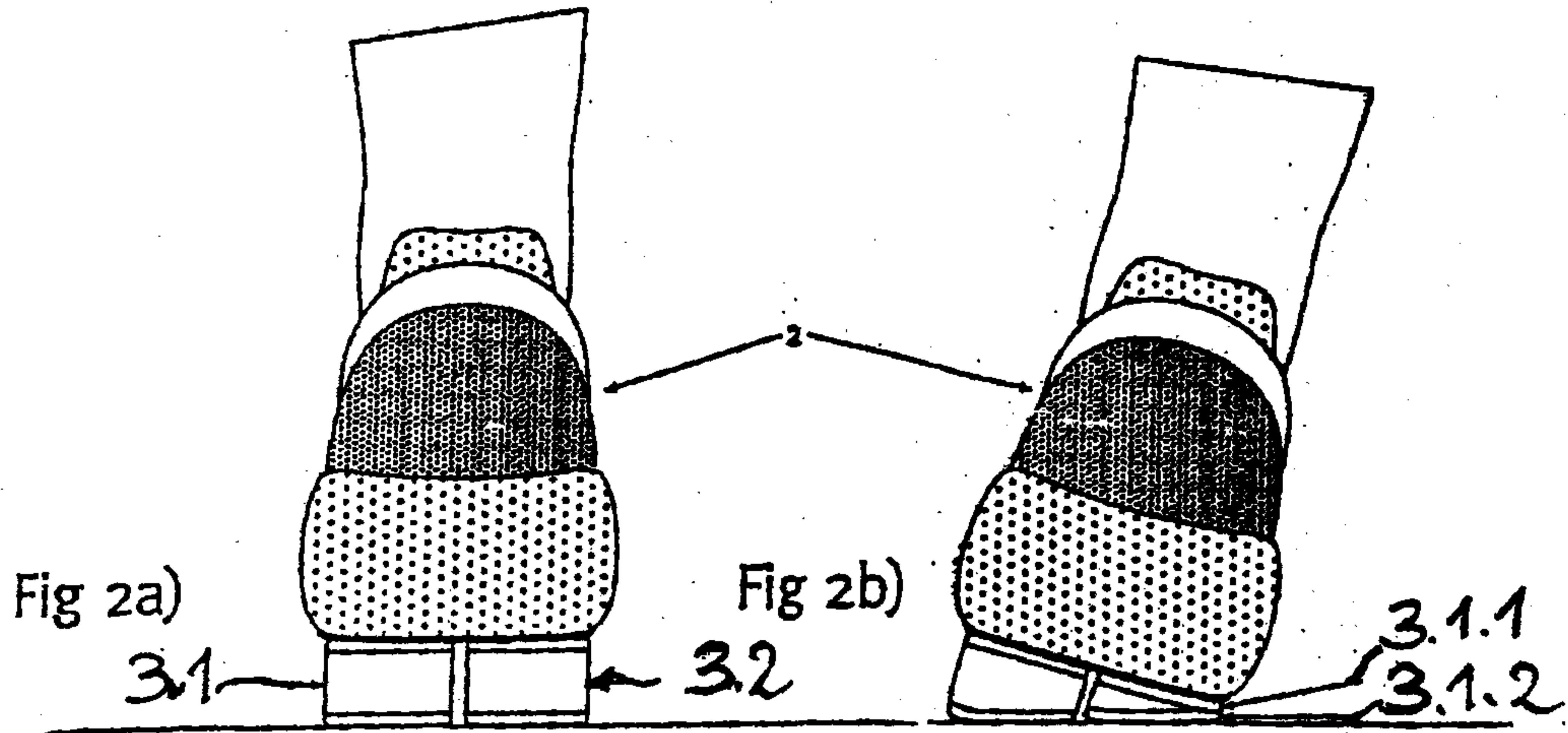



Fig 3a)

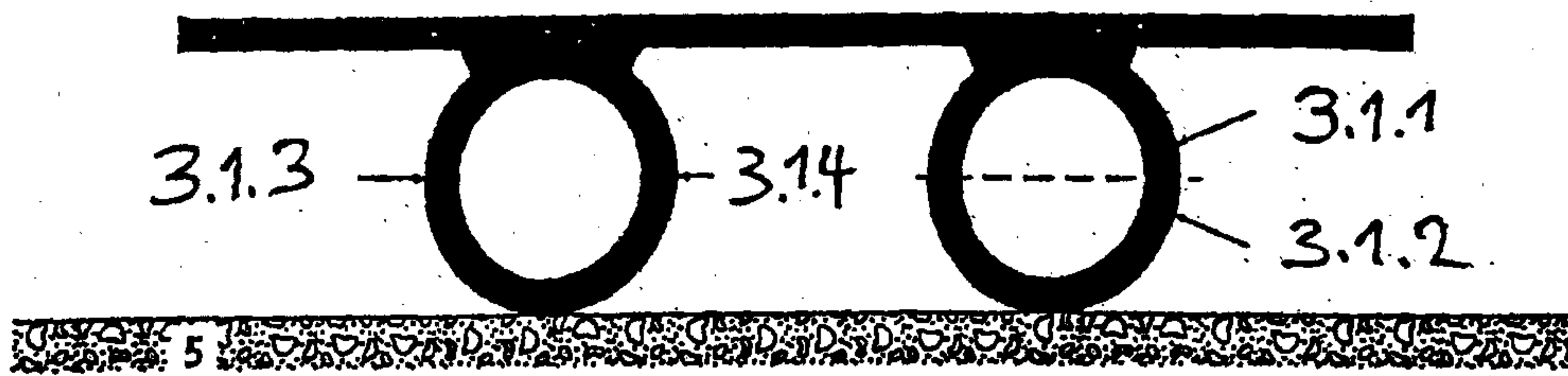

Fig 3b)

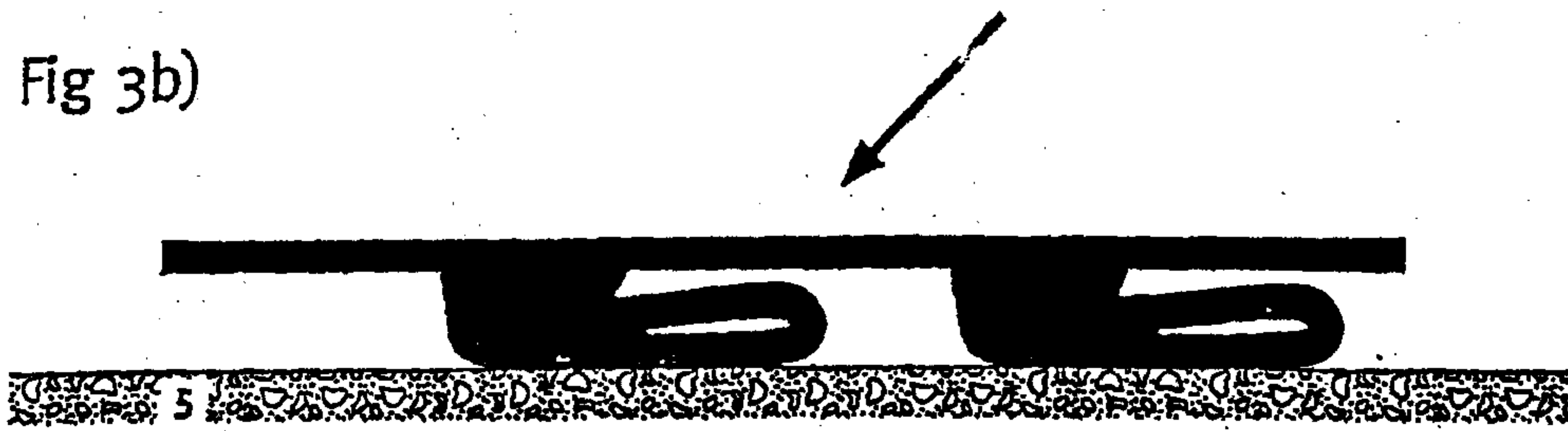
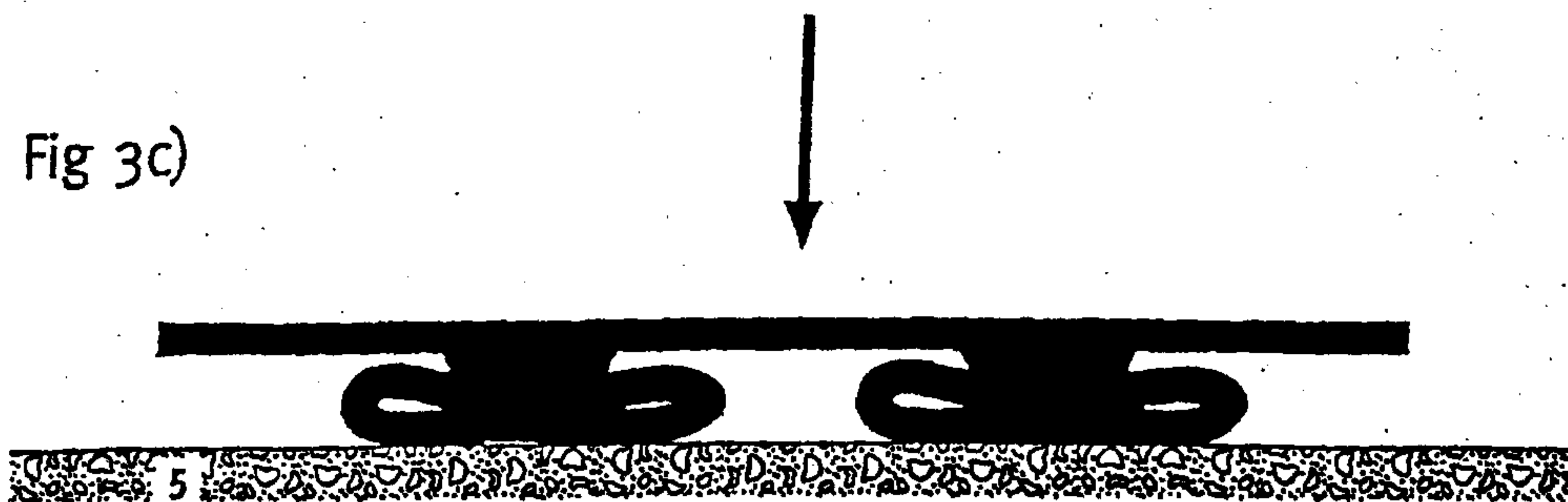

Fig 3c)



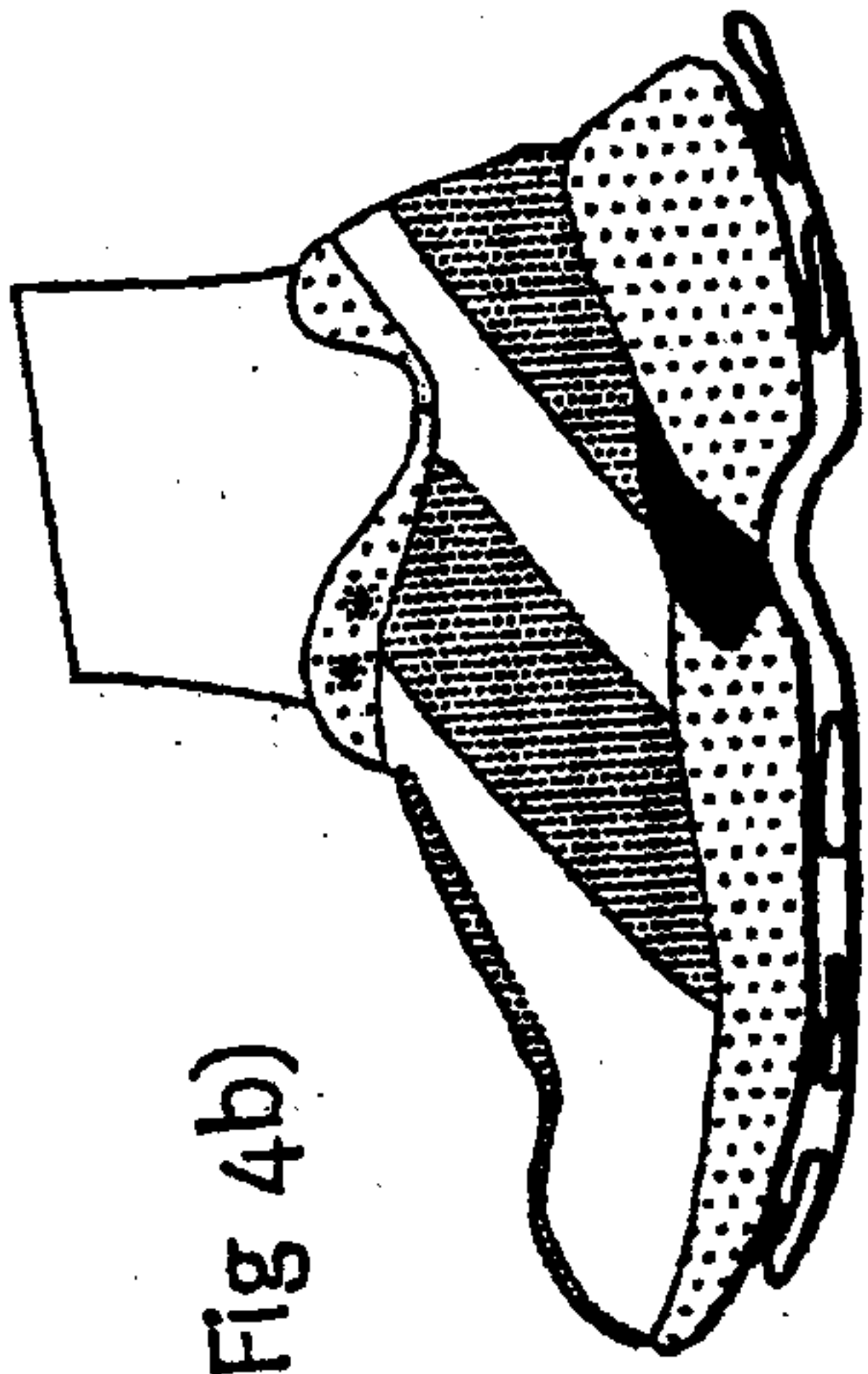

Fig 4b)

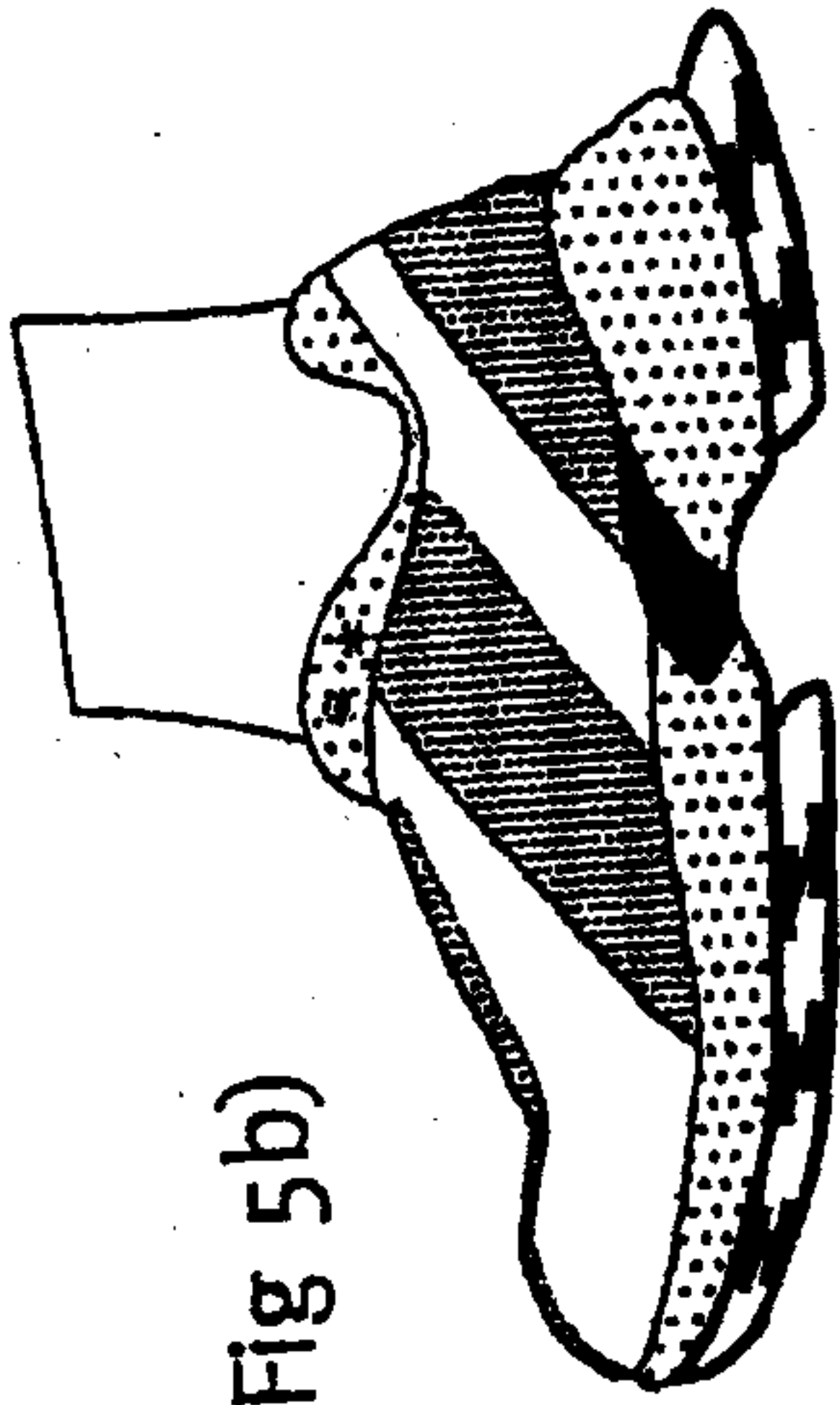

Fig 5b)

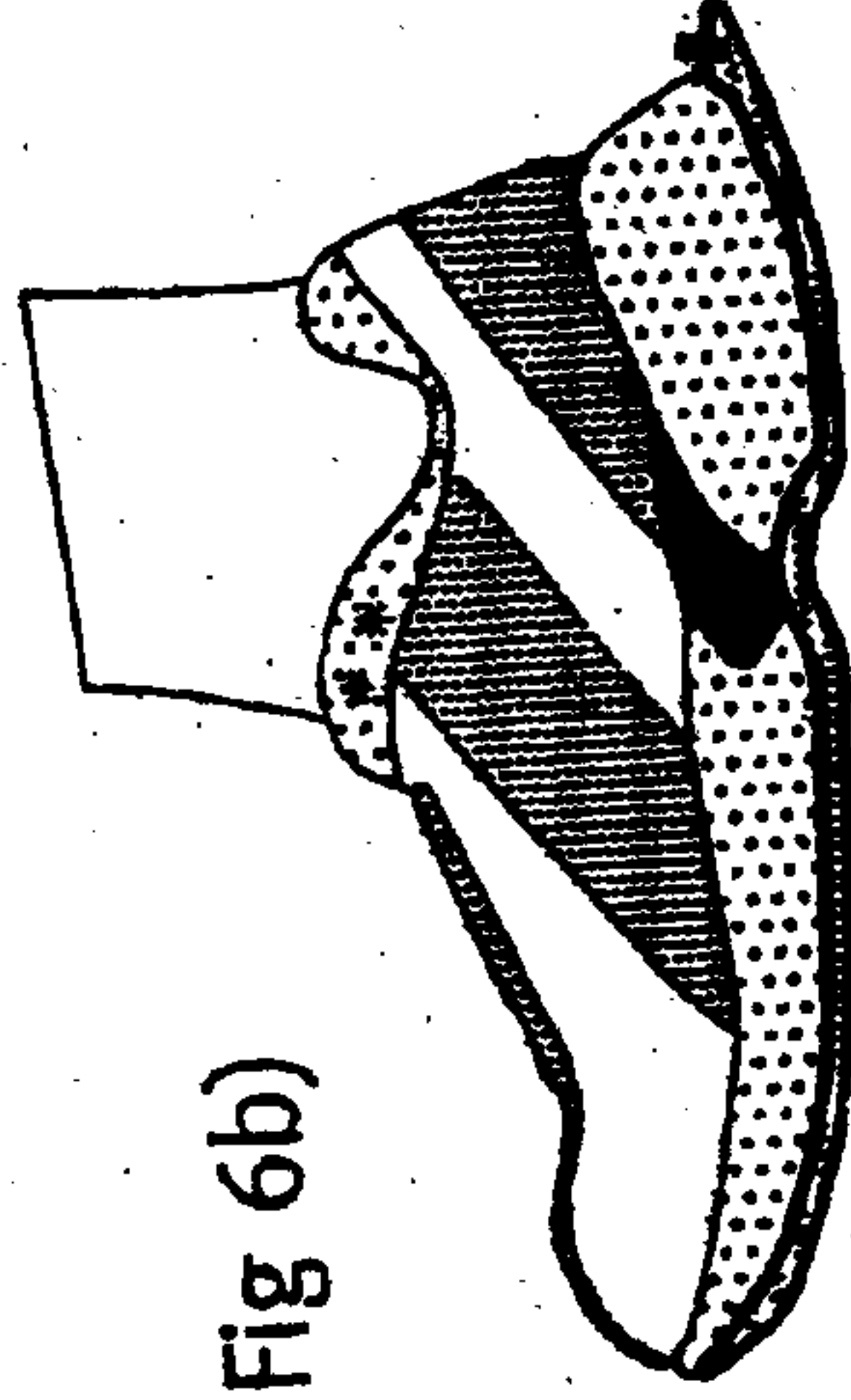

Fig 6b)

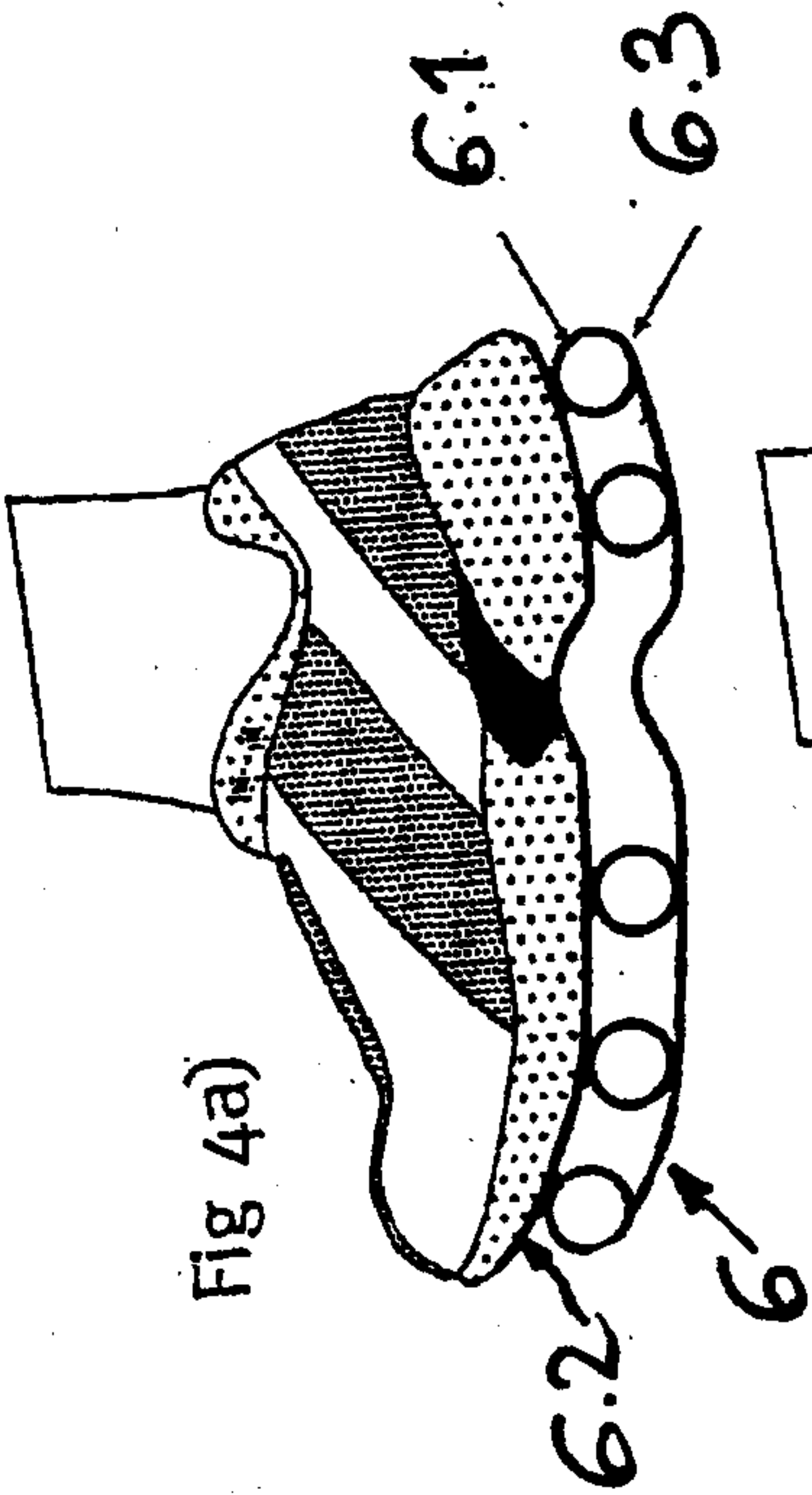

Fig 4a)

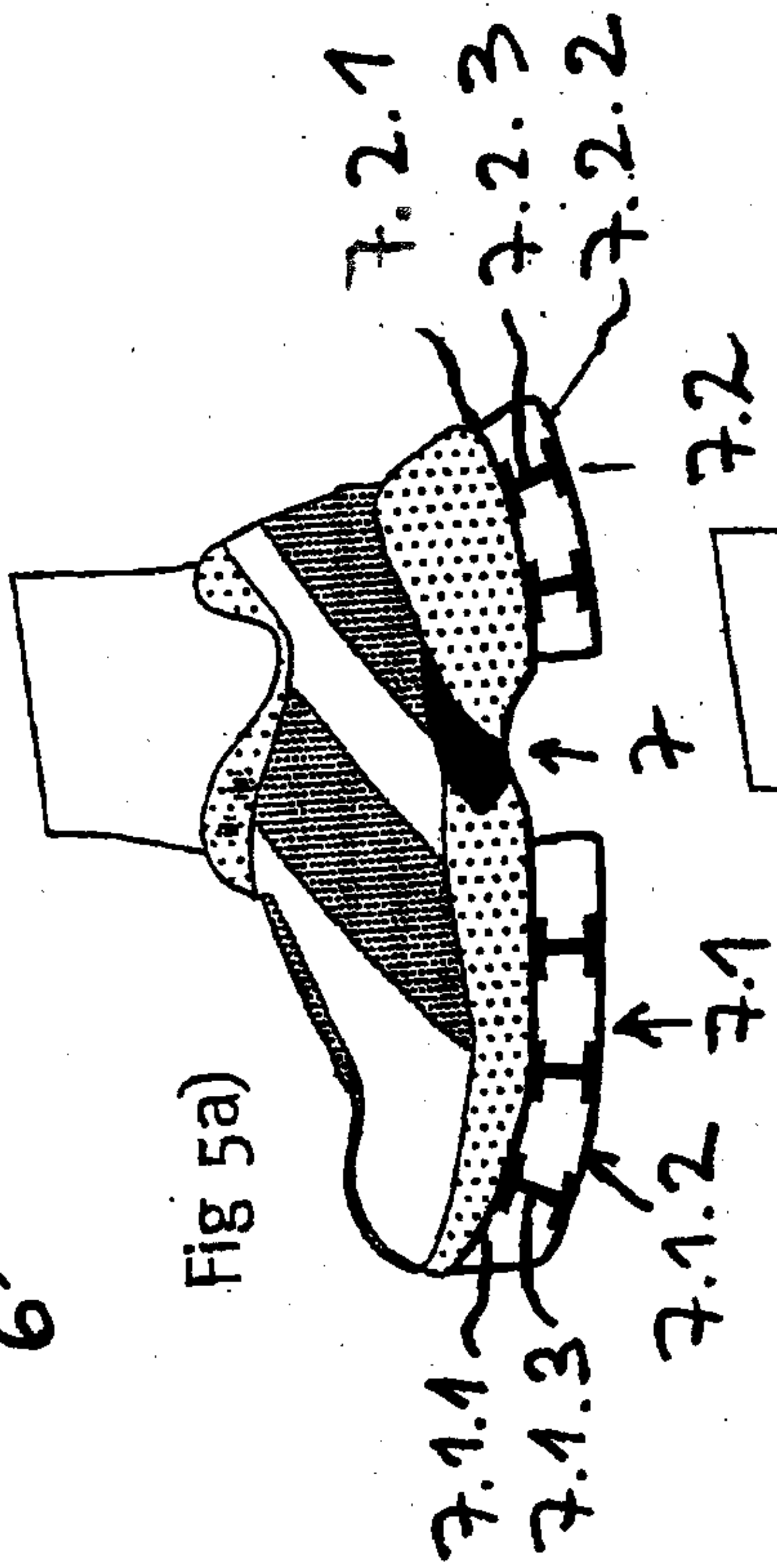

Fig 5a)

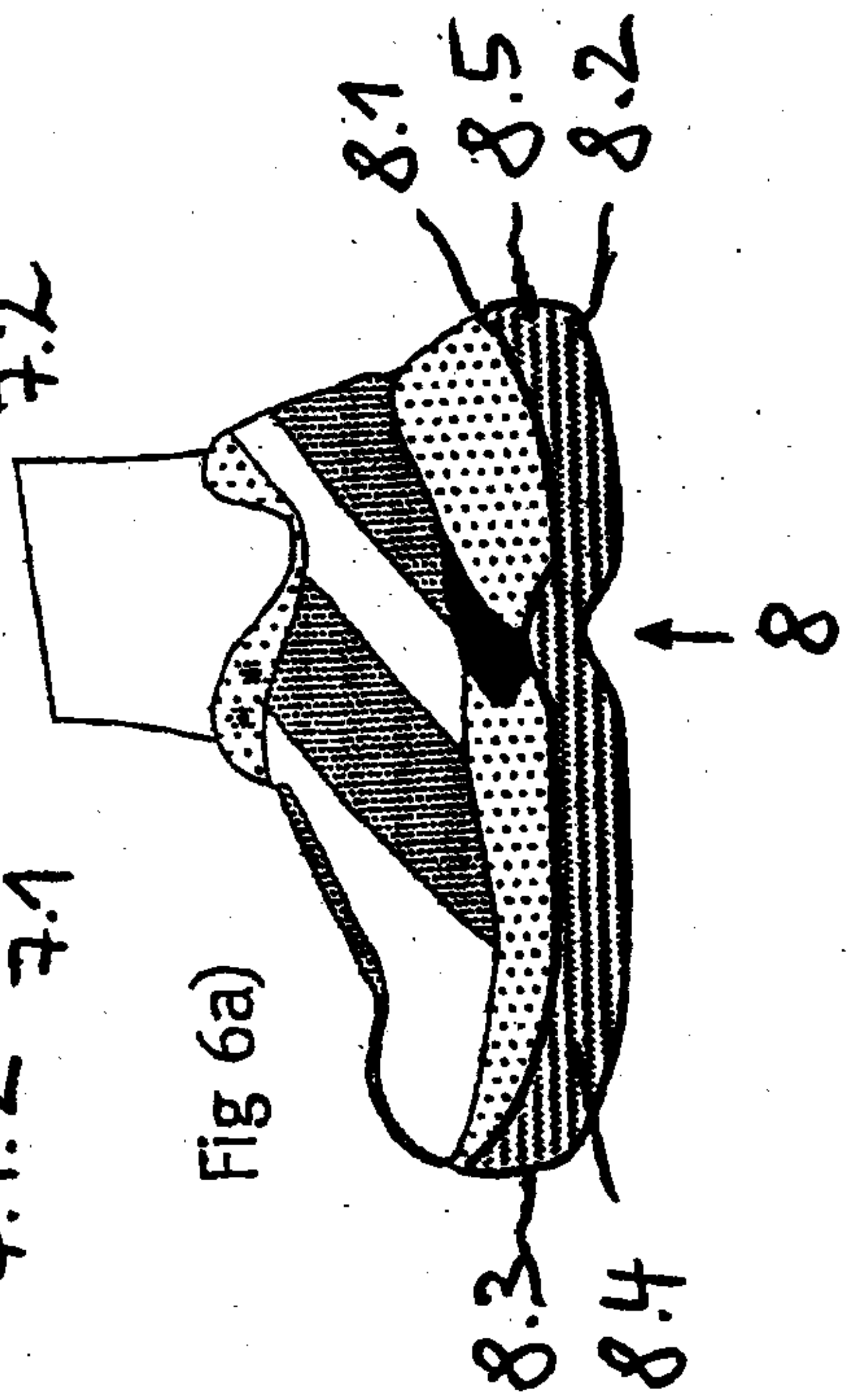

Fig 6a)

5/6

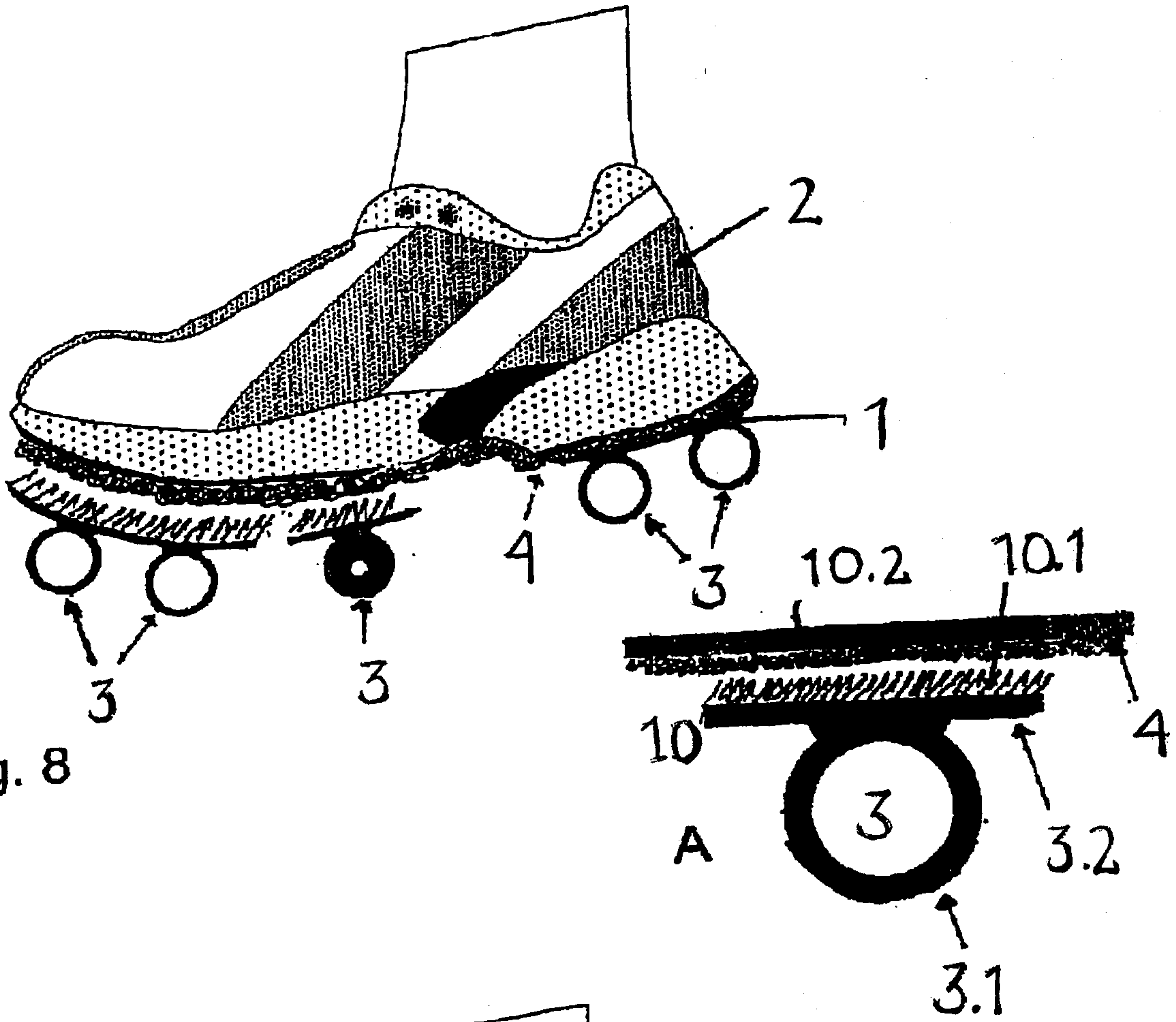

Fig. 8

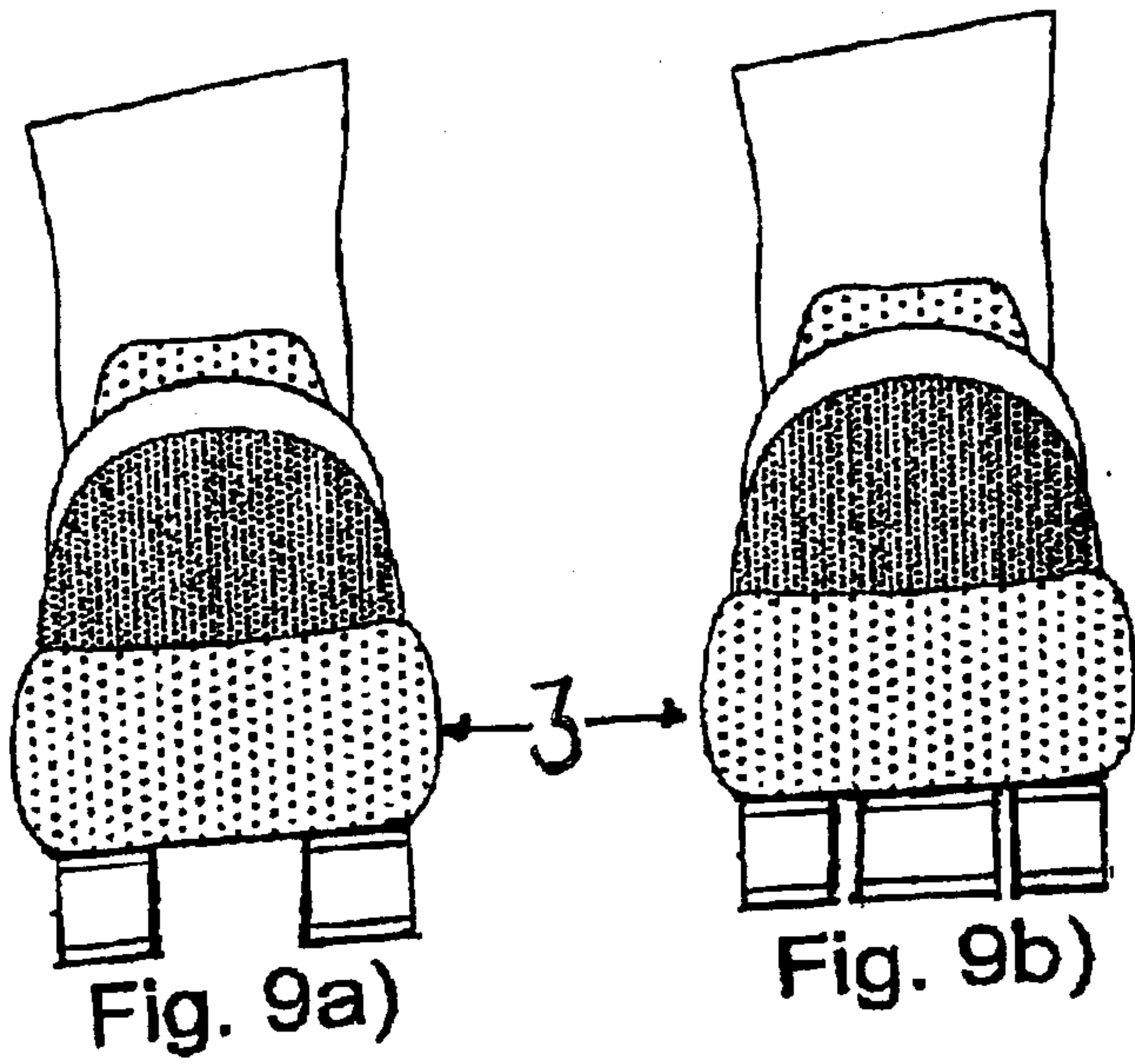

Fig. 9a)

Fig. 9b)

6/6



Fig. 10

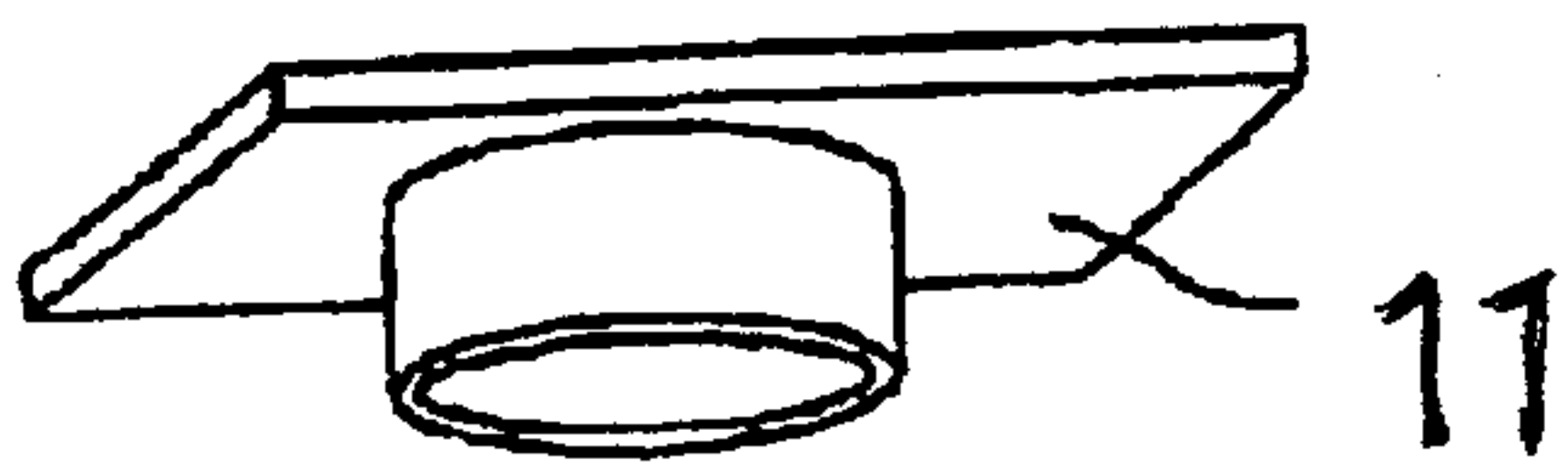

Fig. 11

