

(19) World Intellectual Property Organization
International Bureau



(43) International Publication Date
25 October 2007 (25.10.2007)

PCT

(10) International Publication Number
WO 2007/120371 A2

(51) International Patent Classification:
A47C 1/02 (2006.01)

(21) International Application Number:
PCT/US2007/001409

(22) International Filing Date: 18 January 2007 (18.01.2007)

(25) Filing Language: English

(26) Publication Language: English

(30) Priority Data:
60/792,367 14 April 2006 (14.04.2006) US
11/483,700 10 July 2006 (10.07.2006) US

(63) Related by continuation (CON) or continuation-in-part (CIP) to earlier application:
US 11/483,700 (CON)
Filed on 10 July 2006 (10.07.2006)

(71) Applicant (for all designated States except US):
LA-Z-BOY INCORPORATED [US/US]; 1284 N.
Telegraph Road, Monroe, Michigan 48126 (US).

(72) Inventor; and

(75) Inventor/Applicant (for US only): LAPOINTE, Larry
P. [US/US]; 1066 Substation Road, Temperance, Michigan
48182 (US).

(74) Agents: KELLER, Paul A. et al.; HARNESS, DICKEY
& PIERCE, P.L.C., P.o. Box 828, Bloomfield Hills, Michi-
gan 48303 (US).

(81) Designated States (unless otherwise indicated, for every kind of national protection available): AE, AG, AL, AM, AT, AU, AZ, BA, BB, BG, BR, BW, BY, BZ, CA, CH, CN, CO, CR, CU, CZ, DE, DK, DM, DZ, EC, EE, EG, ES, FI, GB, GD, GE, GH, GM, GT, HN, HR, HU, ID, IL, IN, IS, JP, KE, KG, KM, KN, KP, KR, KZ, LA, LC, LK, LR, LS, LT, LU, LV, LY, MA, MD, MG, MK, MN, MW, MX, MY, MZ, NA, NG, NI, NO, NZ, OM, PG, PH, PL, PT, RO, RS, RU, SC, SD, SE, SG, SK, SL, SM, SV, SY, TJ, TM, TN, TR, TT, TZ, UA, UG, UZ, VC, VN, ZA, ZM, ZW.

(84) Designated States (unless otherwise indicated, for every kind of regional protection available): ARIPO (BW, GH, GM, KE, LS, MW, MZ, NA, SD, SL, SZ, TZ, UG, ZM, ZW), Eurasian (AM, AZ, BY, KG, KZ, MD, RU, TJ, TM), European (AT, BE, BG, CH, CY, CZ, DE, DK, EE, ES, FI, FR, GB, GR, HU, IE, IS, IT, LT, LU, LV, MC, NL, PL, PT, RO, SE, SI, SK, TR), OAPI (BF, BJ, CF, CG, CI, CM, GA, GN, GQ, GW, ML, MR, NE, SN, TD, TG).

Declarations under Rule 4.17:

- as to applicant's entitlement to apply for and be granted a patent (Rule 4.17(ii))
- as to the applicant's entitlement to claim the priority of the earlier application (Rule 4.17(iii))

Published:

- without international search report and to be republished upon receipt of that report

For two-letter codes and other abbreviations, refer to the "Guidance Notes on Codes and Abbreviations" appearing at the beginning of each regular issue of the PCT Gazette.

(54) Title: ROCKING RECLINING CHAIR

(57) Abstract: A furniture item includes a support member and a rotatably pinned mechanism operable in rocking and reclining motions. The mechanism includes first and second side plates; a first pair of forward link members each rotatably connected to one of the side plates; a pantograph linkage set connected to the first pair of forward link members to extend and retract a footrest assembly in the reclining motion; and a drive rod rotatable between the side plates. Rotating the drive rod extends or retracts the pantograph linkage set. An escutcheon connected to the drive rod has a snap-engaged handle to manually rotate the drive rod. At least one U-shaped spring connected between the support member and the mechanism allows rocking motion. A seat pan has flat body springs extending over a seat pan aperture to support an occupant. A detent at one end of each flat spring engages the seat pan.

WO 2007/120371 A2

ROCKING RECLINING CHAIR

CROSS-REFERENCE TO RELATED APPLICATIONS

[0001] This application claims the benefit of U.S. Utility Application No. 5 11/483,700, filed on October 7, 2006, which claims the benefit of U.S. Provisional Application No. 60/792,367, filed on April 14, 2006. The disclosure of the above application is incorporated herein by reference.

FIELD

[0002] The present disclosure relates to furniture member operating 10 mechanisms and to a device and method for operating a reclining furniture member assembly.

BACKGROUND

[0003] The statements in this section merely provide background information related to the present disclosure and may not constitute prior art.

[0004] Conventionally, reclining articles of furniture (i.e., chairs, sofas, 15 loveseats, and the like) require a mechanism to bias a leg rest assembly in the extended and stowed positions. Known mechanisms commonly include a large number of moving parts that tends to increase the manufacturing time and costs associated with the furniture.

[0005] Most reclining rocking chairs include an upholstered chair frame 20 supported from a stationary base assembly in a manner permitting the chair frame to "rock" freely with respect to the base assembly. In order to provide enhanced comfort and convenience, many rocking chairs also include a "reclinable" seat assembly and/or an "extensible" leg rest assembly. For example, combination 25 platform rocking/reclining chairs, as disclosed in Applicant's U.S. Patent Nos. 3,096,121 and 4,179,157, permit reclining movement of the seat assembly and actuation of the leg rest assembly independently of the conventional "rocking" action. The leg rest assembly is operably coupled to a drive mechanism to permit the seat occupant to selectively move the leg rest assembly between its normally 30 retracted (i.e., stowed or retracted) and elevated (i.e., extended or protracted) positions. The drive mechanism is manually-operated and includes a handle which, when rotated by the seat occupant, causes concurrent rotation of a drive

rod for extending or retracting the leg rest assembly. Disadvantages of known mechanisms for providing these functions include a large quantity of parts, and their requirement of one or several spring biasing elements to permit retraction of the various chair components from their extended positions.

5 **[0006]** As an additional comfort feature, a latching mechanism may also be provided for releasably retaining the chair frame in one or more rearwardly rocked or "tilted" positions on the base assembly following extension of the leg rest assembly towards its extended position. In this manner, normal "rocking" action of the rocking chair is inhibited until the leg rest assembly is returned to its normally "stowed" position. Known leg rest mechanisms also provide multiple functional positions, which can be reached using a detente mechanism, which temporarily holds the leg rest at each successive position. Disadvantages of these mechanism designs result as the furniture member rocks backward when the leg rest is moved between the successive positions, and due to the multiple components required to engage and disengage the mechanisms. An improved mechanism is therefore desirable to eliminate the above disadvantages.

10
15

SUMMARY

[0007] According to several embodiments of a rocking reclining chair of the present disclosure, a furniture member includes a support member. A mechanism rotatably pinned to the support member is adapted for both rocking and reclining motions. The mechanism includes opposed first and second side plates; a first pair of forward link members each rotatably connected to one of the first and second side plates; a second pair of rear link members each rotatably connected to one of the first and second side plates; a pantograph linkage set connected to the first pair of forward link members and operable to extend and retract a footrest assembly; and a drive rod supported for rotatable motion between the first and second side plates, rotation of the drive rod operable to each of extend and retract the pantograph linkage set. An escutcheon is selectively and releasably connected to a first end of the drive rod.

20
25
30

The escutcheon has a plurality of connection apertures individually selectable to vary a working length of the drive rod and a width between the first and second side plates.

[0008] According to further embodiments, a furniture member having rocking and reclining functions includes a support member. A mechanism is rotatably pinned to the support member and adapted for both rocking and reclining motions. The mechanism includes opposed first and second side plates; a first pair of forward link members each rotatably connected to one of the first and second side plates; a second pair of rear link members each rotatably connected to one of the first and second side plates; a pantograph linkage set connected to the first pair of forward link members and operable to extend and retract a footrest assembly; and a drive rod supported for rotatable motion between the first and second side plates, rotation of the drive rod operable to each of extend and retract the pantograph linkage set. A base frame supports the support member. At least one biasing member is connected between the base frame and the support member to permit forward and backward rocking motions of the furniture member.

[0009] According to still further embodiments, a furniture member frame includes a seat pan having a homogenous body and a clearance aperture created within a perimeter of the body. A plurality of flat body spring elements are individually non-fastenably connected using a detent element to one of a forward and a rearward facing edge of the seat pan and suspended above the clearance aperture in a non-weight bearing condition. A back frame has opposed first and second back braces, the back frame rotatably supported with respect to the seat pan, the back frame rotatable between each of a fully upright position and a fully reclined position. At least one lumbar flat body spring having a looped feature with a detent element created at opposed ends, the lumbar flat body spring non-fastenably connected to each of the first and second back braces using the looped feature and the detent element.

[0010] According to yet still further embodiments, an escutcheon is selectively and releasably connected to a first end of the drive rod. A handle is snap-engageable on the escutcheon. The handle operates to manually rotate the drive rod.

[0011] According to additional embodiments, a toggle lever is connected to and rotatable in cooperation with the drive rod. A stop drive link is

rotatably connected to each of the first and second side plates. The stop drive link operates in contact with the toggle lever to support the foot rest assembly in successive ratcheting positions.

[0012] Further areas of applicability will become apparent from the description provided herein. It should be understood that the description and specific examples are intended for purposes of illustration only and are not intended to limit the scope of the present disclosure.

DRAWINGS

[0013] The drawings described herein are for illustration purposes only and are not intended to limit the scope of the present disclosure in any way.

[0014] Figure 1 is a perspective view of an un-upholstered rocking reclining chair of the present disclosure;

[0015] Figure 2 is a perspective view of a base frame of the chair of figure 1;

[0016] Figure 3 is side elevational view of the chair of Figure 1 in a fully upright and non-extended position;

[0017] Figure 4 is a side elevational view similar to Figure 3, showing the chair in a fully forward rocked position;

[0018] Figure 5 is a side elevational view similar to Figure 3, showing the chair in a fully rearward rocked position;

[0019] Figure 6 is a side elevational view similar to Figure 3, showing the legrest in a fully extended position;

[0020] Figure 7 is a side elevational view similar to Figure 6, further showing the backrest in a fully reclined position;

[0021] Figure 8 is a side elevational view of the mechanism for the chair of Figure 1;

[0022] Figure 9 is a side elevational view similar to Figure 8, with the legrest mechanism portion partially extended;

[0023] Figure 10 is a side elevational view similar to Figure 8, with the legrest mechanism portion approximately mid-extended;

[0024] Figure 11 is a side elevational view similar to Figure 8, with the legrest mechanism portion fully extended;

[0025] Figure 12 is a side elevational view of a portion of the mechanism in the fully upright position and disengaged from the pawl;

[0026] Figure 13 is a side elevational view similar to Figure 12 of the portion of the mechanism in the legrest extended position having the pawl engaged with the ratchet;

[0027] Figure 14 is a side elevational view of a toggle lever and biasing element of the present disclosure;

[0028] Figure 15 is perspective view of an assembly of a handle, escutcheon, and toggle lever onto a drive rod of the present disclosure;

[0029] Figure 16 is an exploded assembly view of the configuration of Figure 15;

[0030] Figure 17 is a perspective elevational view of an escutcheon engagement drive end of the present disclosure;

[0031] Figure 18 is a perspective assembly view of an escutcheon and handle assembly of the present disclosure;

[0032] Figure 19 is a front perspective view showing the chair of Figure 1 in the legrest and backrest fully extended positions;

[0033] Figure 20 is a rear elevational view of the back frame of the chair of Figure 1;

[0034] Figure 21 is a partial elevational view taken at view 21 of Figure 3;

[0035] Figure 22 is a side elevational view similar to Figure 12 of another embodiment of ratchet and pawl design;

[0036] Figure 23 is the side elevational view of Figure 22, with the chair rotated rearwardly;

[0037] Figure 24 is the side elevational view of Figure 22, with the chair rotated forwardly;

[0038] Figure 25 is the side elevational view of Figure 22, with the legrest extended, resulting in rotation of the mechanism and engagement of the pawl;

[0039] Figure 26 is a perspective view of another embodiment of a base frame modified from the base frame of Figure 2;

[0040] Figure 27 is a perspective view of another embodiment of a back frame; and

[0041] Figure 28 is an end elevational view of the back frame of Figure 27.

DETAILED DESCRIPTION

5 **[0042]** The following description is merely exemplary in nature and is not intended to limit the present disclosure, application, or uses. It should be understood that throughout the drawings, corresponding reference numerals indicate like or corresponding parts and features.

[0043] Referring generally to Figure 1, a rocking reclining chair 10 includes a body 12, a base frame 14 supporting the body 12, and a mechanism 16 supported by both the base frame 14 and body 12. Body 12 is divisible into each of a chair frame section 18 and a back frame section 20. Chair frame section 18 includes a seat pan 22 which according to several embodiments includes a unitary piece of material such as plywood, composite material, or similar structurally homogenous, jointless body. A clearance aperture 24 is provided in seat pan 22 providing downward displacement space for an occupant of rocking reclining chair 10. Mechanism 16 includes linkages, motion inserts, and connecting members that are similar to United States Patent application 11/328,722 filed January 10, 2006, entitled "WALL PROXIMITY RECLINING CHAIR WITH IN-LINE LINKAGE MECHANISM", the subject matter of which is incorporated herein by reference.

[0044] Chair frame 18 further includes a first arm support 26 and an opposite second arm support 28. First arm support 26 is connected to a first front post 30 and second arm support 28 is connected to a second front post 32. Each of the first and second arm supports 26, 28 are connected to their respective front posts 30, 32 using a mortise/tenon joint 34. The mortise/tenon joints 34 are selected to maximize the joint strength for the joined components which are substantially perpendicular to each other. A double-notched joint 36 is created by notching each of seat pan 22 and both first and second front posts 30, 32 to mechanically join seat pan 22 to each of the first and second arm supports 26, 28.

[0045] Chair frame 18 still further includes each of a first and second lower rail 38, 40 connected to first and second front posts 30, 32 respectively. First and second lower rails 38, 40 are connected to each of first and second front posts 30, 32 using a rabbet joint 42. Chair frame 18 also includes each of a first and second rear post 44, 46. First rear post 44 is connected to both first arm support 26 and first lower rail 38. Similarly, second rear post 46 is connected to both second arm support 28 and second lower rail 40. A first filler post 48 is connected between first arm support 26 and the connection area between first rear post 44 and first lower rail 38. Similarly, a second filler post 50 is connected between second arm support 28 and the joint created between second rear post 46 and second lower rail 40. First and second filler posts 48, 50 provide a curved geometry to visually complete the rearward section of chair frame 18.

[0046] Back frame 20 includes a first back brace 52 and a second back brace 54 having an upper cross rail 56 and a lower cross rail 58 connected between first and second back braces 52, 54. For appearance and to provide suitable area for upholstery, a first back extension 60 is connected to first back brace 52 and a second back extension 62 is connected to second back brace 54. Each of the first and second back extensions 60, 62 can be connected to their respective first and second back brace 52, 54 using each of a first extension spacer 64 and a second extension spacer 66. A foot rest panel 68 is mechanically coupled to mechanism 16 and extendable from the stowed position shown.

[0047] Referring now generally to Figure 2, base frame 14 is created by connecting each of three substantially equivalent members including a first side channel 70, a second side channel 72 and a first cross channel 74. An overlapping joint 76, 76' is created at the connection between first side channel 70 and first cross channel 74 and between second side channel 72 and first cross-channel 74 respectively. A foot mount fastener 78 is used to threadably fasten a fixed foot 80, 80' to each of first side channel 70 and second side channel 72 respectively. Each fixed foot 80, 80' can be non-adjustable or in alternate embodiments can also be height adjustable. An adjustable height foot

81, 81' is used at the overlapping joints 76, 76' to permit height adjustability of base frame 14. Each of the first and second side channels and first cross channel, 70, 72, 74 include a first flange 82 and a second flange 84 oriented substantially perpendicular to first flange 82, defining a substantially L-shaped member. A plurality of apertures 86 are created in each of the second flanges 84. A first U-shaped leaf spring 88 is fastenably connected using apertures 86 to the second flange 84 of first side channel 70. Similarly, a second U-shaped leaf spring 90 is fastenably connected using apertures 86 to second flange 84 of second side channel 72. First and second U-shaped leaf springs 88, 90 are created of spring steel in several embodiments and are operable to permit a rocking motion for rocking reclining chair 10. Each of the first and second U-shaped leaf springs 88, 90 directly abut the second flange 84 of their appropriate side channels. A stiffener brace 92 is positioned in direct contact with each of the first and second U-shaped leaf springs 88, 90 and fastened through the appropriate leaf spring and second flange using a plurality of fasteners 96.

[0048] Base frame 14 further includes a pawl 98 which in several embodiments is created of a spring steel, and includes an attachment end 100 connected to an attachment brace 94 using a pawl mount fastener 102. Attachment brace 94 is constructed similar to first and second side channels 70, 72 and first cross channel 74 but is of different length. Attachment brace 94 is mounted to stiffener brace 92 and to second flange 84 of first cross channel 74 using a plurality of fasteners 96. Pawl 98 further includes a ratchet engaging end 104 which in several embodiments is a polymeric member fixed or non-releasably connected to a distal end of pawl 98. Ratchet engaging end 104 can also be releasably connected to pawl 98 if replacement is anticipated.

[0049] Referring now to Figure 3, chair frame 18 can further include a reinforcing brace 106 angularly positioned between seat pan 22 and each of first and second front posts 30, 32. Reinforcing braces 106 provide additional rigidity for chair frame 18. Mechanism 16 includes a lower flange' 108 of a mechanism support member 110. Lower flange 108 provides apertures for a plurality of fasteners 112 which are used to fastenably connect each of first and second U-shaped leaf springs 88, 90 to lower flange 108 on opposed sides of mechanism

16. The weight of an occupant of rocking reclining chair 10 is supported by each of a first plurality of flat body springs 114 and a second plurality of flat body springs 116. Flat body springs 114, 116 are defined having a width substantially greater than a thickness. In several embodiments, flat body springs 114, 116 are created of spring steel, or an elastically deflectable polymeric or composite material. Each of the first plurality of flat springs 114 are connected to seat pan 22 at a forward facing edge 115 of seat pan 22. Conversely, each of the second plurality of flat springs 116 are connected to a rearward facing edge 117 of seat pan 22. For example, a looped end 118 of each of the first plurality of flat springs 114 is pre-formed to substantially conform to the geometry of seat pan 22.

[0050] Each of the first plurality of flat springs 114 also includes a free end 120 which when an occupant is not present is freely suspended above seat pan 22, and upon receiving the weight of the occupant is deflected downward into a contact position with seat pan 22 and thereafter allow flat springs 114 to compress vertically, while translating in contact with seat pan 22. Similarly, a looped end 122 is created for each of the connections between the second plurality of flat springs 116 and the rearward facing edge of seat pan 22. A free end 124 similar to free end 120 is provided at a forward end of each of the second plurality of flat springs 116 and function similar to free ends 120 of the first plurality of flat springs 114. A longitudinally rigid connecting member 126 which can be created of the same material as first and second flat springs 114, 116 is positioned substantially perpendicular to each of the first and second plurality of flat springs 114, 116 and used to join each of the first and second plurality of flat springs 114 and 116. The connection between each of the first and second plurality of flat springs 114, 116 to seat pan 22 is created by the detent elements which are described in reference to Figure 21. Each of the first and second plurality of flat springs 114, 116 has the free ends 120, 124 freely suspended above seat pan 22 in a non-weight or non-load bearing condition, defined as a condition with no occupant on chair 10. Each of the free ends 120, 124 slidably contact seat pan 22 in a load or weight bearing condition, defined as occupant seated on chair 10 and downwardly loading the first and second

plurality of flat springs 114, 116. Due to the use of detent elements, no fasteners are required to engage any of the first or second plurality of flat springs 114, 116 with seat pan 22. This reduces the time of construction as well as the cost of rocking reclining chair 10. Frictional engagement of the respective looped ends
5 118, 122 with seat pan 22 occurs in the weight bearing condition.

[0051] At least one and in several embodiments a plurality of flat springs are also used to help support the weight of an occupant to back frame 20. For this purpose, at least one first lumbar flat spring 128 is connected to each of the first and second back braces 52, 54. In several embodiments a
10 second lumbar flat spring 130 is also connected to both first and second back braces 52, 54. First and second lumbar flat springs 128, 130 each also include opposed looped ends each similar to looped ends 118, 122 such that no mechanical fasteners are required to engage first or second lumbar flat springs 128, 130 with either of first or second back braces 52, 54. According to other
15 embodiments, only a single lumbar flat spring is used, or three or more lumbar flat springs can be used. Material for the first and second back braces 52, 54 can be a spring steel, or material providing similar elastic properties.

[0052] Mechanism 16 can further include each of a toggle lever 132, a forward support link 134, and a rear support link 136. Toggle lever 132 is
20 connected to a drive rod 138 which in several embodiments is square or rectangular in shape, can be solid or in tubular form, and is created of a metal or composite material. In several embodiments, toggle lever 132 is created of a polymeric material and each of the forward support link 134, rear support link 136, and drive rod 138 are created of a steel material. Each of the forward and
25 rear support links 134, 136 are rotatably connected to mechanism support member 110 to allow motion of various components of mechanism 16. Figure 3 shows rocking reclining chair 10 in a closed, or fully upright, non-extended, and non-rocked position.

[0053] Referring now generally to Figure 4, rocking reclining chair 10 is
30 shown in a forward rocked position which is achieved when an occupant leans forward and body 12 rotates about an arc of rotation "A" with respect to both first and second U-shaped leaf springs 88, 90. The position of back frame 20 with

respect to base frame 14 and the orientation of each of forward and rear support links 134, 136 with respect to mechanism support member 110 are unchanged in the fully forward rocked position with respect to the position of rocking reclining chair 10 shown in Figure 3. Foot rest panel 68 is also positioned in the withdrawn or fully retracted position similar to its position shown in Figure 3.

5 [0054] As best seen in reference to Figure 5, a fully rearward rocked position of rocking reclining chair 10 is shown. To reach this position, the weight of the occupant is positioned rearward with respect to first and second U-shaped leaf springs 88, 90 to rotate rocking reclining chair 10 from the fully upright position shown in Figure 3 about an arc of rotation "B" with respect to each of the first and second U-shaped leaf springs 88, 90. In the fully rearward rocked position, each of the first and second filler posts 48, 50 are retained above the elevation of fixed feet 80, 80' so no other component of rocking reclining chair 10 contacts a ground or floor surface other than the support feet. Similar to the fully forward rocked position shown in Figure 4, no other component of rocking reclining chair 10 is displaced with respect to the fully upright position shown in Figure 3 when the rocking reclining chair 10 is repositioned to the fully rearward rocked position.

15 [0055] Referring now to Figure 6, rocking reclining chair 10 is repositioned from the upright position shown in Figure 3 to a leg rest fully extended position. To accomplish this, drive rod 138 is rotated counter-clockwise in a drive rod rotation arc "C" which releases toggle lever 132. Each of forward and rear support links 134 and 136 rotate with respect to each of a first and second pinned joint 140, 142 respectively, to allow portions of mechanism 16 to displace in a translation direction "D". This translation permits foot rest panel 68 to be displaced about a leg rest extension arc "E" with pantograph linkages 144 extending forward and outward. As forward and rear support links 134, 136 rotate, each of first and second filler posts 48, 50 rotate and lower with respect to base frame 14 in a substantially downward arc "F". Each of first and second front posts 30, 32 are repositioned from a substantially upright or vertical position within an angle of rotation α which reorients the occupant toward a slightly upward viewing angle identified generally as a "TV position". Back frame

20 does not rotate during the displacement of foot rest panel 68, and mechanism support member 110 remains substantially parallel to base frame 14.

[0056] Each of a first and a second motion insert 146, 148 which are pre-connected to a connecting plate 150 include respectively a first elongated slot 152 and a second elongated slot 154. An upper end of forward support link 134 is pinned via a first motion pin 156 positioned within first elongated slot 152. Similarly, rear support link 136 is pinned via a second motion pin 158 positioned within second elongated slot 154. In the foot rest fully extended position shown, each of the first and second motion pins 156, 158 are positioned substantially in their forward-most position with respect to each the first and second elongated slots 152, 154.

[0057] Referring now generally to Figure 7, rocking reclining chair 10 is further shown having back frame 20 rotated rearward from the leg rest fully extended position shown in Figure 6 to achieve a fully reclined position of rocking reclining chair 10. A seat back support arm 160, 160' (160' is not shown in this view) which are connected to each of first and second back braces 52, 54 are rotatably pinned using seat back rotation pins 162, 162' (162' is not visible in this view). First and second back braces 52, 54 are therefore rotatable about a seat back arc of rotation "G" about seat back rotation pins 162, 162' to reach the fully reclined position. The fully reclined position is achieved with the weight of the occupant directed toward back frame 20 causing back frame 20 to rotate about seat back arc of rotation "G". As also shown in Figure 7, in the fully reclined position, first and second motion pins 156, 158 are displaced within each of their respective first and second elongated slots 152, 154 to a fully rearward position within the first and second elongated slots 152, 154.

[0058] Also during displacement of back frame 20 to the fully reclined position, a pin 163 connected between seat back support arm 160 and an arc link 164 causes rotation of a rotating link 165. Rotation of rotating link 165 causes an upward and forward displacement of both first and second filler posts 48, 50 which reduces rearward displacement of back frame 20, thereby reducing the amount of wall clearance required behind rocking reclining chair 10 to achieve the fully reclined position. In several embodiments, a wall clearance

dimension "Z" of eight to ten inches is required between back frame 20 and a wall 166 when back frame 20 is in the fully upright position to allow back frame 20 to rotate toward wall 166 and reach the fully reclined position. A stop drive link 167 is also connected to connecting plate 150. Stop drive link 167 rotates
5 when drive rod 138 is rotated until stop drive link 167 contacts a rotation stop pin 168 which prevents further rotation of foot rest panel 68. A stop drive member 169 is also connected to drive rod 138 which is also rotatably connected to stop drive link 167 which functions to limit the rotation of drive rod 138.

[0059] Referring now generally to Figure 8, mechanism 16 is more
10 clearly shown in the fully upright position of rocking reclining chair 10 with respect to an occupant's left hand side of mechanism 16. Part numbers having prime values are therefore substantially equivalent to the same parts on the operator's right hand side of mechanism 16. A foot rest mount plate 170 is provided at distal ends of each of the pantograph linkages 144, 144' to which
15 foot rest panel 68 is fastened. A cam 171 is also provided which allows the installer and/or the user to select the amount of downward force that is required to move foot rest panel 68 from the fully upright to the fully extended position. Cam 171 provides at least two and in several embodiments three alternate positions sequentially selectable to allow an increasing amount of weight to be
20 borne by the leg rest assembly. Therefore the manufacturer or user can adjust mechanism for a lighter weight or heavier weight occupant to maintain the leg rest fully extended position before motion back to the leg rest fully upright position is allowed.

[0060] Stop drive link 167' is pinned for rotation with stop drive
25 member 169'. Stop drive link 167' is further rotatably mounted to connecting plate 150' and can rotate about a mounting pin 179' when various cam surfaces of toggle lever 132' in response to rotation of drive rod 138 contact an arm 175' of stop drive link 167'. A biasing element 172, 172' which in several
30 embodiments is a coiled spring biases stop drive link 167 or stop drive link 167' to an over-center position helping to maintain the fully upright position of mechanism 16. Arm 175' contacts a first cam surface 177' of toggle lever 132' in the fully upright position.

[0061] Referring now to Figure 9, foot rest mount plate 170 is shown in a partially extended position which results when drive rod 138 is rotated about arc of rotation "H" which displaces stop drive member 169' connected to a displacement link 173'. Displacement link 173' in turn displaces each of a substantially parallel pair of first and second foot rest motion links 176', 178'. First and second foot rest motion links 176', 178' in turn are pinned to and displace pantograph linkages 144'. Drive rod 138 rotates toggle lever 132' which in turn rotates arm 175' of stop drive link 167' (counterclockwise as viewed in Figure 9) by contact of a curved second cam surface 181' of toggle lever 132' with arm 175'.

[0062] As best seen in reference to Figure 10, continued rotation of drive rod 138 about arc of rotation "H" further displaces foot rest mount plate 170. Drive rod 138 continues to rotate toggle lever 132' which in turn rotates arm 175' of stop drive link 167' (counterclockwise as viewed in Figure 10) by contact with a substantially flat third cam surface 183' of toggle lever 132'.

[0063] As best seen in reference to Figure 11, the fully extended position of foot rest mount plate 170 is reached when arm 175' of stop drive link 167' contacts rotation stop pin 168'. Toggle lever 132' rotates arm 175' of stop drive link 167' (counterclockwise as viewed in Figure 11) by contact with a substantially flat fourth cam surface 185' of toggle lever 132' which forces arm 175' into contact with stop pin 168', preventing further rotation of stop drive link 167', toggle lever 132' and drive rod 138. At the fully extended position, forward and rear support links 134', 136' have rotated with respect to mechanism support member 110' allowing mechanism 16 to fully translate in the translation direction "D".

[0064] Referring now to Figure 12, when rocking reclining chair 10 is in the fully upright position having forward and rear support links 134, 136 in their substantially upright position shown, the forward and rear support links 134, 136 are co-rotatably connected using a cross link 180 pinned at opposite ends using first and second motion pins 156, 158. A first cross brace 182 is connected between forward support links 134, 134' and a second cross brace 184 is similarly connected between each of the rear support links 136, 136'. In several

embodiments, a ratchet 186 is fixedly connected to first cross brace 182. Ratchet 186 provides a plurality of teeth 188. In the fully upright position shown, the ratchet engaging end 104 of pawl 98 does not contact any of teeth 188.

[0065] Referring now to Figure 13, as foot rest panel 68 is extended
5 and each of forward and rear support links 134, 136 rotate about first and second pinned joints 140, 142, cross link 180 together with forward and rear support links 134, 136 are repositioned in the translation direction "D" which moves ratchet 186 to the right as shown in Figure 13 until ratchet engaging end 104 of pawl 98 engages in a first engagement position 190 between any first two
10 of the teeth 188. Engagement of ratchet engaging end 104 in the first engagement position 190 helps retain foot rest panel 68 in the extended position. Disengagement of ratchet engaging end 104 and return to the position shown in Figure 12 is accomplished by rearward rotation of forward and rear support links 134, 136 and movement of cross link 180 substantially in a return direction "J".
15 While in the leg rest extended position, further backward rotation of foot rest panel 68 will reposition ratchet engaging end 104 between any subsequent pair of the teeth 188 which retains the foot rest panel 68 at multiple, increasing elevations with respect to a floor or support surface.

[0066] As best seen in reference to Figure 14, toggle lever 132
20 includes a toggle body 192 to which is connected a toggle extension 194. This is accomplished by aligning a male tab 195 of toggle extension 194 with a female slot 196 of toggle body 192 and rotating toggle extension 194 to the position shown. Toggle extension 194 is thereafter prevented from dislocation from toggle body 192 unless and until male tab 195 is rotated to re-align with female
25 slot 196. Toggle body 192 further includes a first bearing member 197 having a substantially rectangular aperture 198 created therein. Rectangular aperture 198 receives drive rod 138. A second bearing member 200 includes a circular aperture 202. A keyed aperture 204 having a female slot 205 similar to female slot 196 is provided for an alternate installation location of toggle extension 194
30 for embodiments having rocking reclining chair 10 operated by a latch release mechanism (not shown). Toggle extension 194 includes multiple apertures including a first adjustment aperture 208, a second adjustment aperture 210 and

a third adjustment aperture 212. Adjustment apertures 208, 210 and 212 are adapted to receive a first hooked end 214 of a biasing element 216. A second hooked end 218 of biasing element 216 is connected to structure extending from connecting plate 150. By positioning first hooked end 214 in any one of the first, second or third adjustment apertures 208, 210, or 212 an over-center biasing force can be either increased or decreased which affects the amount of torque applied to drive rod 138 to release mechanism 16 from the fully upright position and into for example the leg rest extended position.

[0067] As best seen in reference to Figure 15, toggle lever 132 is shown as it is nominally positioned on drive rod 138. At one end of drive rod 138 a handle 220 is connected which is used to manually rotate drive rod 138 to either release or engage mechanism 16 in either the extended or retracted positions. Handle 220 is connected to an escutcheon 222. Escutcheon 222 can be positioned along various locations of drive rod 138 to allow a single drive rod 138 to be used in multiple width embodiments of rocking reclining chair 10. A releasable pin 224 is provided to engage escutcheon 222 with drive rod 138. A total length or spacing "S" of the assembly is determined by the location that releasable pin 224 is placed. The ability to control spacing "S" provides the manufacturer the option to multiple assemblies of the handle 220, escutcheon 222, and drive shaft 138 which allows the same parts to be used in furniture members having a plurality of widths.

[0068] Referring now generally to Figure 16, for adjusting both toggle lever 132 and escutcheon 222 on drive rod 138, a tubular portion 226 of escutcheon 222 includes a plurality of apertures 228. Each of the apertures 228 are created as opposed pairs having an alternate or secondary one of the apertures oppositely positioned (not visible in this view) about tubular portion 226. Drive rod 138 includes an escutcheon engagement end 230 having at least one and in several embodiments a plurality of pin alignment apertures 232. To engage escutcheon 222 on drive rod 138 the tubular portion 226 is slidably disposed over the escutcheon engagement end 230 until one of the plurality of apertures 228 aligns with one of the pin alignment apertures 232. Releasable

pin 224 is then inserted through the aligned ones of apertures 228 and pin alignment apertures 232 to releasably engage escutcheon 222.

[0069] Escutcheon 222 further includes a skirt 234 having a diameter large enough to visually cover an aperture created through upholstered sections of rocking reclining chair 10 necessary for insertion of tubular portion 226. An engagement drive end 236 is created in several embodiments by co-molding engagement drive end 236 with skirt 234. Engagement drive end 236 includes a substantially rectangular drive rod receiving through aperture 238 which is sized to correspond to the geometry of drive rod 138 and to provide external dimensions which are suitable for engaging engagement drive end 236 with handle 220.

[0070] Toggle lever 132 further includes a toggle tube portion 240 which also includes at least one and in several embodiments a plurality of tube apertures 242 which are aligned with corresponding apertures of drive rod 138. A second releasable pin 244 is thereafter received in the aligned ones of tube apertures 242 through toggle tube portion 240 and the corresponding tube apertures of drive rod 138. According to several embodiments drive rod 138 can also include a generally-U-shaped portion 246. U-shaped portion 246 is provided in several embodiments to increase a clearance below the first and second plurality of flat springs 114, 116 which support the occupant of rocking reclining chair 10 when a weight of an occupant downwardly deflects the flat springs 114, 116, and to provide clearance for motion of the first pair of forward link members 134, 134' and the second pair of rear link members 136, 136', as well as any other moving elements of mechanism 16.

[0071] As best seen in reference to both Figures 17 and 18, installation of handle 220 on escutcheon 222 proceeds as follows. Engagement drive end 236 is provided with at least one sloped engagement tooth 248 which includes a raised edge 250 facing skirt 234. Sloped engagement tooth 248 can be provided on at least one of the flat faces created on the substantially rectangularly shaped engagement drive end 236. An engagement drive end receiving portion 251 of handle 220 receives the generally rectangularly shaped engagement drive end 236 in a correspondingly sized and shaped engagement drive aperture 252

created in receiving portion 251. To insert handle 220 onto escutcheon 222, a pitched alignment slot 254 aligned with and directed toward engagement drive aperture 252 is aligned with sloped engagement tooth 248. Handle 220 is engaged with engagement drive end 236 by displacement in a handle attachment direction "K". Thereafter, handle 220 is pressed or hammered to drive sloped engagement tooth 248 past pitched alignment slot 254 until the raised edge 250 and sloped engagement tooth 248 engage within a tooth engagement aperture 256 also created with the engagement drive aperture 252, defining a snap fit. Sloped engagement tooth 248 is designed to elastically and not permanently deflect during installation so raised edge 250 can thereafter provide a retention capability to prevent handle 220 from being removed from engagement drive end 236. This snap fit connection is therefore intended to be a substantially permanent connection, however the skilled practitioner will recognize that a sufficient force can be applied to remove handle 220 if desired.

[0072] Referring now to Figure 19, the weight of an occupant displaces first and second flat springs 114 and 116 in a downward direction "L". The free ends 120, 124 of flat springs 114, 116 initially deflect in the downward direction "L" until they contact seat pan 22. Thereafter, the free ends 120, 124 can longitudinally displace, in sliding contact with seat pan 22. For example the free ends 124 of flat springs 116 displace in a forward direction "M". The free ends 120 of flat springs 114 will oppositely displace. Flat springs 114 and 116 can also deflect into clearance aperture 24 of seat pan 22, creating greater weight bearing capacity for chair 10.

[0073] Referring now generally to Figure 20, back frame 20 is viewed from a rear side looking forward. From this orientation it is evident that first and second lumbar flat springs 128, 130 can be created having a curved geometry, and in the example shown the curved geometry presents an upwardly directed arc whose tangent is greatest at the center location positioned between the connecting points of each of first and second lumbar flat springs 128, 130 with their connections at first and second back braces 52, 54. In several additional embodiments, first and second lumbar flat springs 128, 130 can also be

substantially straight or can be curved in an opposite orientation from that shown.

[0074] Referring now to Figure 21, first and second flat springs 114, 116 each include a bend location 258. Bend locations 258 transition the curving portion of the spring body used for support of the occupant into a flattened portion of the spring positioned proximate to the looped ends. Only looped end 122 is shown for first flat springs 116. Flat springs 114 are oppositely installed. The looped end 122 turns a portion of the spring to face substantially forward and below seat pan 22. A curved portion or detent 260 is created defining an engagement end of each of the first and second flat springs 114, 116. Each detent 260 is received within a detent cavity 262 created in seat pan 22. Because the width across looped ends 118 and 122 is substantially equal to a thickness of seat pan 22, an elastic spring force is created when detents 260 are pressed over the ends of seat pan 22. This spring force initially displaces and thereafter retains the detents 260 in the detent cavities 262 to resist removal of the flat springs. Each of the free ends 120, 124 is defined by a concavely upward curving portion which when abutted with seat pan 22 under the weight of the occupant allows the flat springs to longitudinally lengthen and displace along a plane defined by the upward facing surface of seat pan 22. This sliding motion of the spring free ends occurs as the springs deflect when loaded with the occupant's weight, and as the springs return to the unloaded or freely extending position shown in Figure 21 when the weight of the occupant is removed.

[0075] Referring now generally to Figure 22, in several embodiments, a ratchet 264 and pawl 266 are modified from ratchet 186 and pawl 98. Pawl 266 includes a rearwardly facing catch end 268. Ratchet 264 includes a plurality of upwardly directed teeth 270, which are oppositely oriented with respect to the generally downwardly directed teeth 188 of ratchet 186. Also provided in this view is an extended length U-shaped leaf spring 272, which replaces both first and second U-shaped leaf springs 88, 90 with a single leaf spring. Leaf spring 272 also eliminates the need for stiffener brace 92 and attachment brace 94 of Figure 2.

[0076] With reference to Figure 23, a rearward rocking motion of chair 10 about leaf spring 272 does not result in contact between catch end 268 and teeth 270. Pawl 266 is retained in the non-engaged, non-deflected condition. Catch end 268 does not engage teeth 270 because forward and rear support links 134, 136 do not rotate as chair 10 rocks rearwardly about leaf spring 272.

[0077] With reference to Figure 24, a forward rocking motion of chair 10 about leaf spring 272 also does not result in contact between catch end 268 and any of teeth 270, however, catch end 268 can contact a ledge 274 created in ratchet 264. Engagement of catch end 268 with ledge 274 provides a positive stop to further forward rotation of chair 10. Catch end 268 does not engage teeth 270 during forward rocking motion because forward and rear support links 134, 136 do not rotate as chair 10 rocks forwardly about leaf spring 272.

[0078] Referring now to Figures 13 and 25, as the leg rest of chair 10 is extended outwardly, forward and rear support links 134, 136 (as well as links 134' and 136' not visible in this view) rotate about first and second pinned joints 140, 142 in a clockwise direction as viewed in Figure 25. Cross link 180 and ratchet 264 effectively translate in translation direction "D" which positions teeth 270 for engagement by catch end 268. Further movement in translation direction "D" deflects pawl 266 as shown, placing pawl 266 in tension. This operation is opposite to the operation of ratchet 186 and pawl 98, wherein pawl 98 is placed in compression when teeth 188 of ratchet 186 engage attachment end 100. Because pawl 266 operates in tension, a body thickness "N" of pawl 266 can be reduced relative to a corresponding body thickness of pawl 98. This reduces weight and cost of pawl 266.

[0079] Referring now in general to Figures 2 and 26, in several embodiments, a base frame 275 is modified from base frame 14. Use of U-shaped leaf spring 272 in base frame 275 permits the elimination of first cross channel 74, stiffener brace 92, and attachment brace 94 from the configuration of base frame 14 (shown in Figure 2). A width "P" of leaf spring 272 is greater than first and second leaf springs 88 and 90, thereby increasing torsional strength and resistance to fore/aft deflection of leaf spring 272, permitting elimination of the above described items. A spring cavity 276 faces rearwardly

or opposite to the corresponding spring cavities of springs 88, 90. Leaf spring 272 can further include a spring extension flange 278 which provides additional support surface area for installation of a mounting flange 280 of pawl 266 using pawl mount fastener 102. Leaf spring 276 can also be connected to each of the
5 second flanges 84 of first and second side channels 70, 72 using fasteners 96. A cut-out area 282 can be provided as necessary for additional deflection clearance for pawl 266. In operation, leaf spring 272 permits both forward and rearward rocking or rotation of chair 10.

[0080] Referring now to Figures 27 and 28, a back frame 284 is
10 modified from back frame 20 and is created of a single piece frame element 286 similar to seat pan 22. A clearance aperture 288 is also provided in frame element 286 to provide for displacement of first and second lumbar flat springs 128, 130 (not shown). First and second back braces 52, 54 are provided similar
15 to back frame 20. First and second back extensions 60, 62 are provided to support upholstery sections (not shown) similar to back frame 20. First and second mounting brackets 290, 292 are fastenably connected to each of first and second back braces 52, 54 and are adapted to be connected to mechanism 16
--- to permit rotation of back-frame 284. In several embodiments, an upper oriented cross element 294 has a width "Q" of approximately 63.5 cm (25.4 in) and can
20 be narrower than a lower oriented cross element 296 having a width "R" of approximately 67.1 cm (26.4 in). A total height "T" of frame element 286 can be approximately 43.7 cm (17.2 in).

CLAIMS

What is claimed is:

1. A furniture member, comprising:
- 5 a support member;
- a mechanism rotatably connected to the support member and adapted for both rocking and reclining motions, including:
- opposed first and second side plates;
- 10 a first pair of forward link members each rotatably connected to one of the first and second side plates;
- a pantograph linkage set connected to the first pair of forward link members and operable to extend and retract a footrest assembly; and
- 15 a drive rod supported for rotatable motion between the first and second side plates, rotation of the drive rod operable to each of extend and retract the pantograph linkage set; and
- an escutcheon selectively and releasably connected to a first end of the drive rod, the escutcheon having a plurality of connection apertures individually selectable to vary a working length of the drive rod and a width
- 20 between the first and second side plates.
2. The furniture member of Claim 1, further comprising:
- a base frame having a plurality of rotatable pinned connections operable to rotatably support the mechanism; and
- 25 at least one U-shaped biasing member connected between the base frame and the mechanism operable to permit forward and backward rocking motions of the furniture member.
3. The furniture member of Claim 2, wherein the support member further comprises first and second side elements.
4. The furniture member of Claim 3, wherein the at least one U-
- 30 shaped biasing member further comprises first and second biasing members, each connected to one of the first and second side elements.

5. The furniture member of Claim 3, wherein the at least one U-shaped biasing member further comprises a single extended length biasing member connected to both of the first and second side elements.

6. The furniture member of Claim 1, further comprising a releasable pin insertable through an individual one of the plurality of connection apertures and the drive rod.

7. The furniture member of Claim 2, wherein the base frame comprises first and second lateral members and one transverse member coupled to the first and second lateral members.

8. The furniture member of Claim 1, further comprising:
a second pair of rear link members each rotatably connected to one of the first and second side plates and adapted for co-rotation with the first pair of rear link members; and

a U-shaped central portion the drive rod provided for motion clearance for the first pair of forward link members and the second pair of rear link members.

9. A furniture member having rocking and reclining functions, comprising: -

a support member;

a mechanism rotatably pinned to the support member and adapted for both rocking and reclining motions, including:

opposed first and second side plates;

a first pair of forward link members each rotatably connected to one of the first and second side plates;

a second pair of rear link members each rotatably connected to one of the first and second side plates;

a pantograph linkage set connected to the first pair of forward link members and operable to extend and retract a footrest assembly; and

a drive rod supported for rotatable motion between the first and second side plates, rotation of the drive rod operable to each of extend and retract the pantograph linkage set;

a base frame operable to support the support member; and
at least one biasing member connected between the base frame
and the support member operable to permit forward and backward rocking
motions of the furniture member.

5 10. The furniture member of Claim 9, further comprising:
a first cross brace connecting the first pair of forward link members;
and
a second cross brace connecting the second pair of rear link
members.

10 11. The furniture member of Claim 10, further comprising:
a pawl assembly connected to the first cross brace; and
a ratchet connected to the support member;
wherein a forward rotation of the first pair of forward link members
moves the pawl assembly into an engaged position with the ratchet, the ratchet
15 being in compression.

12. The furniture member of Claim 11, wherein the pawl assembly
further comprises a plurality of substantially downward directed teeth.

20 13. The furniture member of Claim 10, further comprising:
a pawl assembly connected to the second cross brace; and
a ratchet connected to the support member;
wherein a forward rotation of the first pair of forward link members
moves the pawl assembly into an engaged position with the ratchet, the ratchet
being in tension.

25 14. The furniture member of Claim 13, wherein the pawl assembly
further comprises a plurality of substantially upward directed teeth.

30 15. The furniture member of Claim 9, further comprising:
first and second lateral elements of the base frame;
wherein the at least one biasing member further includes first and
second U-shaped springs each connected between the support member and
one of first and second lateral elements of the base frame.

16. The furniture member of Claim 9, further comprising:
first and second lateral elements of the base frame;

wherein the at least one biasing member further comprises an extended length U-shaped spring connected between the first and second lateral elements of the base frame.

17. A furniture member frame, comprising:

5 a seat pan having a homogenous body and a clearance aperture created within a perimeter of the body;

a plurality of flat body spring elements individually non-fastenably connected using a detent element to one of a forward and a rearward facing edge of the seat pan and suspended above the clearance aperture in a non-weight bearing condition;

10 a back frame having opposed first and second back braces, the back frame rotatably supported with respect to the seat pan, the back frame rotatable between each of a fully upright position and a fully reclined position; and

15 at least one lumbar flat body spring having a looped feature with a detent element created at opposed ends, the lumbar flat body spring non-fastenably connected to each of the first and second back braces using the looped feature and the detent element.

20 18. The furniture member frame of Claim 17, wherein the plurality of flat body spring elements further comprises a first group of elements each connected using the detent element to the forward facing portion of the seat pan, each element of the first group further including a first free end freely suspended above the seat pan proximate the rearward facing portion of the seat pan in the non-weight bearing condition.

25 19. The furniture member frame of Claim 18, wherein the plurality of flat body spring elements further comprises a second group of elements each connected using the detent element to the rearward facing portion of the seat pan, each element of the second group further including a second free end freely suspended above the seat pan proximate the forward facing portion of the seat pan in the non-weight bearing condition.

30 20. The furniture member of Claim 19, wherein each of the first and second free ends further define a concave shape, the first and second free ends

slidably contacting the seat pan in a weight bearing condition wherein the plurality of flat body spring elements is downwardly deflectable by a weight of an occupant of the furniture member.

5 21. The furniture member of Claim 17, further comprising a substantially longitudinally rigid connecting member connected to and perpendicularly oriented with respect to the plurality of flat body spring elements.

22. The furniture member of Claim 17, further comprising first and second front posts and first and second rear posts each connected to the seat pan using a notched joint.

10 23. The furniture member of Claim 22, further comprising first and second arm supports connected to individual ones of the first and second front posts using a mortise and tenon joint.

15 24. The furniture member of Claim 23, further comprising first and second lower rails each connected to individual ones of the first and second front posts and the first and second rear posts using a plurality of open notched joints.

25. The furniture member of Claim 17, wherein the seat pan comprises a single sheet of plywood material.

26. The furniture member of Claim 17, wherein the seat pan comprises a single sheet of polymeric material.

20 27. A furniture member, comprising:
a support member;
a mechanism rotatably pinned to the support member and adapted for both rocking and reclining motions, including:

25 opposed first and second side plates;
a first pair of forward link members each rotatably connected to one of the first and second side plates;

a pantograph linkage set connected to the first pair of forward link members and operable to extend and retract a footrest assembly;
and

30 a drive rod supported for rotatable motion between the first and second side plates, rotation of the drive rod operable to each of extend and retract the pantograph linkage set;

an escutcheon selectively and releasably connected to a first end of the drive rod; and

a handle snap-engageable on the escutcheon, the handle operable to manually rotate the drive rod.

5 28. The furniture member of Claim 27, further comprising a base frame operable to support the support member.

29. The furniture member of Claim 28, comprising at least one biasing member connected between the base frame and the support member operable to permit forward and backward rocking motions of the furniture member.

10 30. The furniture member of Claim 27, wherein the escutcheon further comprises:

a tubular portion operable to receive the drive rod;

a skirt having a diameter larger than the tubular portion; and

15 an engagement drive end extending outwardly from the skirt and oppositely oriented with respect to the tubular portion, the engagement drive end operable to receive the handle.

20 31. The furniture member of Claim 30, wherein the handle comprises an engagement drive end-receiving portion having an engagement drive aperture corresponding in shape to a substantially rectangular shape of the engagement drive end.

32. The furniture member of Claim 31, wherein the handle further comprises:

a pitched engagement slot created at the engagement drive aperture; and

25 a tooth engagement aperture aligned with the pitched engagement slot.

30 33. The furniture member of Claim 32, wherein the engagement drive end of the escutcheon further comprises a sloped engagement tooth extending outwardly from the engagement end and operable to engage within the tooth engagement aperture defining a snap-fit of the handle with the escutcheon.

34. The furniture member of Claim 27, wherein the escutcheon comprises a plurality of connection apertures individually selectable to receive a

releasable pin to vary a working length of the drive rod and a width between the first and second side plates.

35. A furniture member, comprising:

a support member;

5 a mechanism rotatably pinned to the support member and adapted for at least a reclining motion, including:

opposed first and second side plates;

a first pair of forward link members each rotatably connected to one of the first and second side plates;

10 a second pair of rear link members each rotatably connected to one of the first and second side plates;

a pantograph linkage set connected to the first pair of forward link members and operable to extend and retract a legrest assembly; and

15 a drive rod supported for rotatable motion between the first and second side plates, rotation of the drive rod operable to each of extend and retract the pantograph linkage set;

-- a toggle-lever assembly connected to and rotatable in cooperation with the drive rod; and

20 a stop drive link rotatably connected to each of the first and second side plates, the stop drive link operable in contact with the toggle lever to support the legrest assembly in successive ratcheting positions.

25 36. The furniture member of Claim 35, further comprising a biasing element connected between the stop drive link and each of the first and second side plates, the biasing element operable to bias the stop drive link to an over-center position when the furniture member is in a fully upright position.

37. The furniture member of Claim 35, further comprising a rotation stop pin connected to each of the first and second side plates operable to define a maximum rotated position of the stop drive link.

30 38. The furniture member of Claim 35, wherein the toggle lever assembly further comprises:

a toggle body having a female slot positioned proximate a circular aperture; and

5 a toggle extension rotatably coupled to the toggle body, the toggle extension including a male tab adapted to be received in the female slot, rotation of the toggle extension relative to the toggle body operable to retain the male tab out of alignment with the female slot.

39. The furniture member of Claim 38, further comprising:

a plurality of aligned adjustment apertures created in the toggle extension; and

10 a biasing element having opposed hooked ends, a first one of the hooked ends engageable within a predetermined one of the plurality of adjustment apertures to one of increase and decrease a legrest assembly retention force.

40. The furniture member of Claim 38, wherein the toggle body further
15 comprises a first bearing member having a substantially rectangularly shaped aperture operable to receive the drive rod.

41. The furniture member of Claim 38, wherein the toggle body further
-- -- comprises a keyed aperture having a second female slot, the keyed aperture
defining a second installation location for the toggle extension.

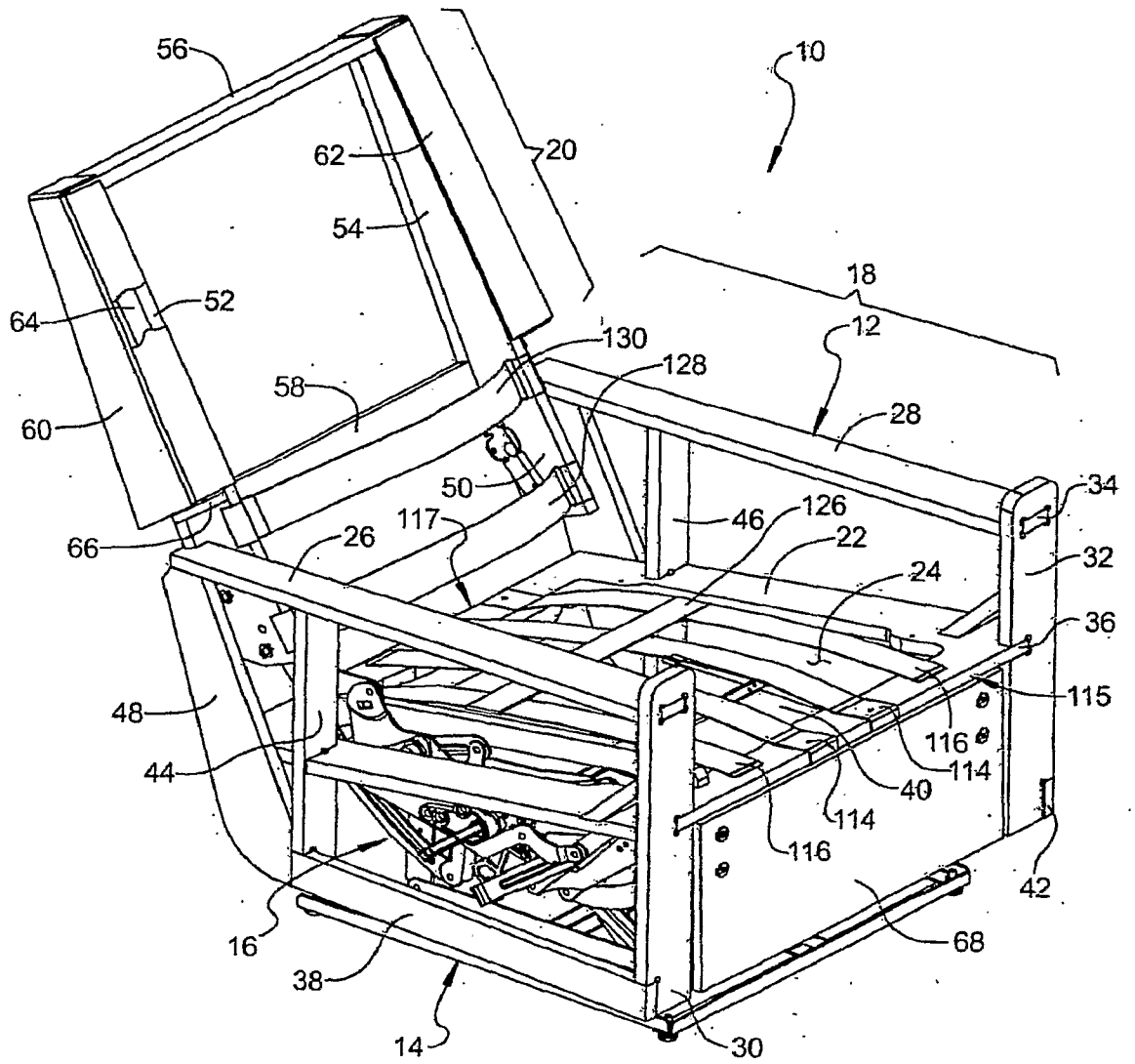

FIG 1

2/27

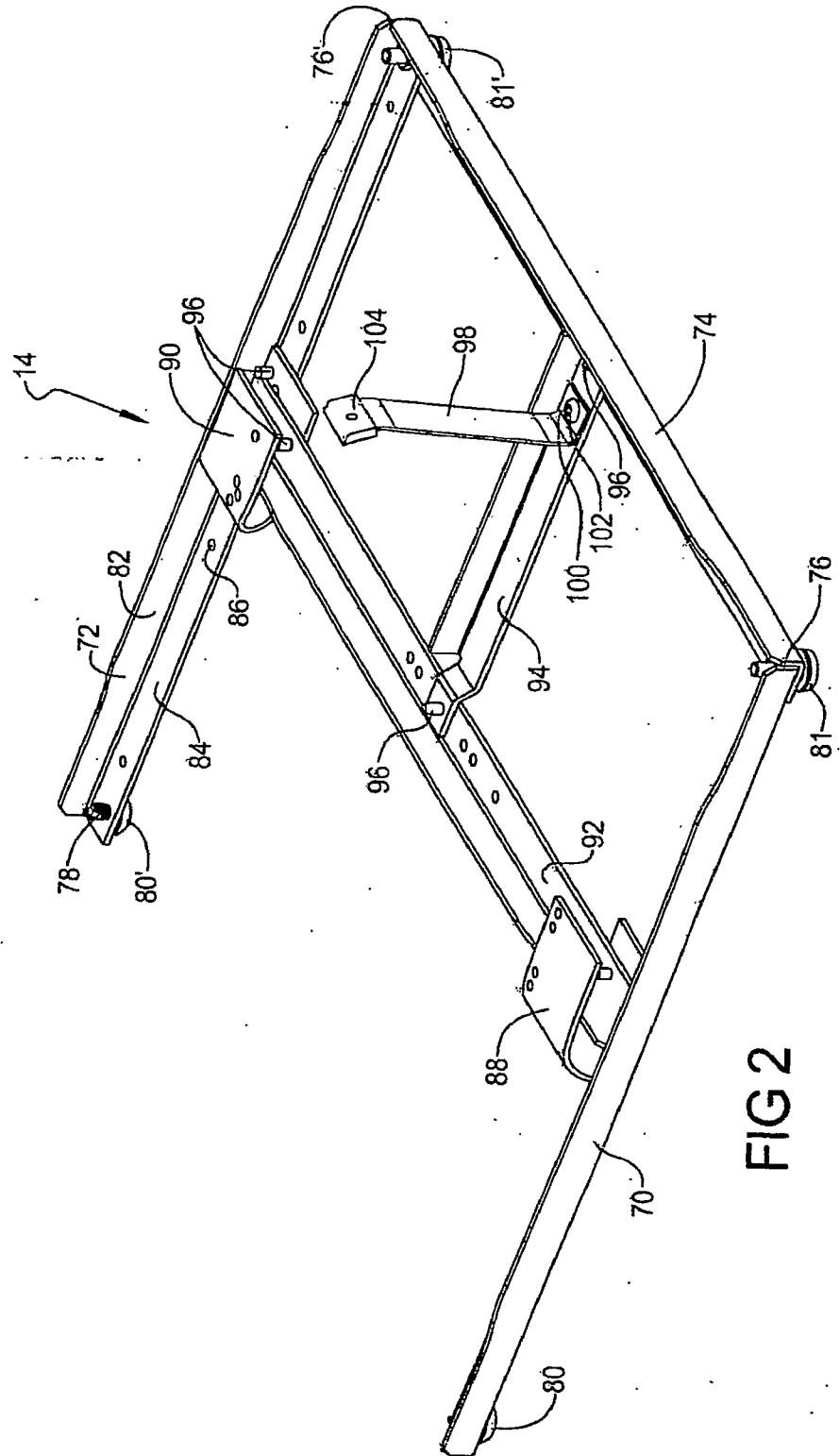

FIG 2

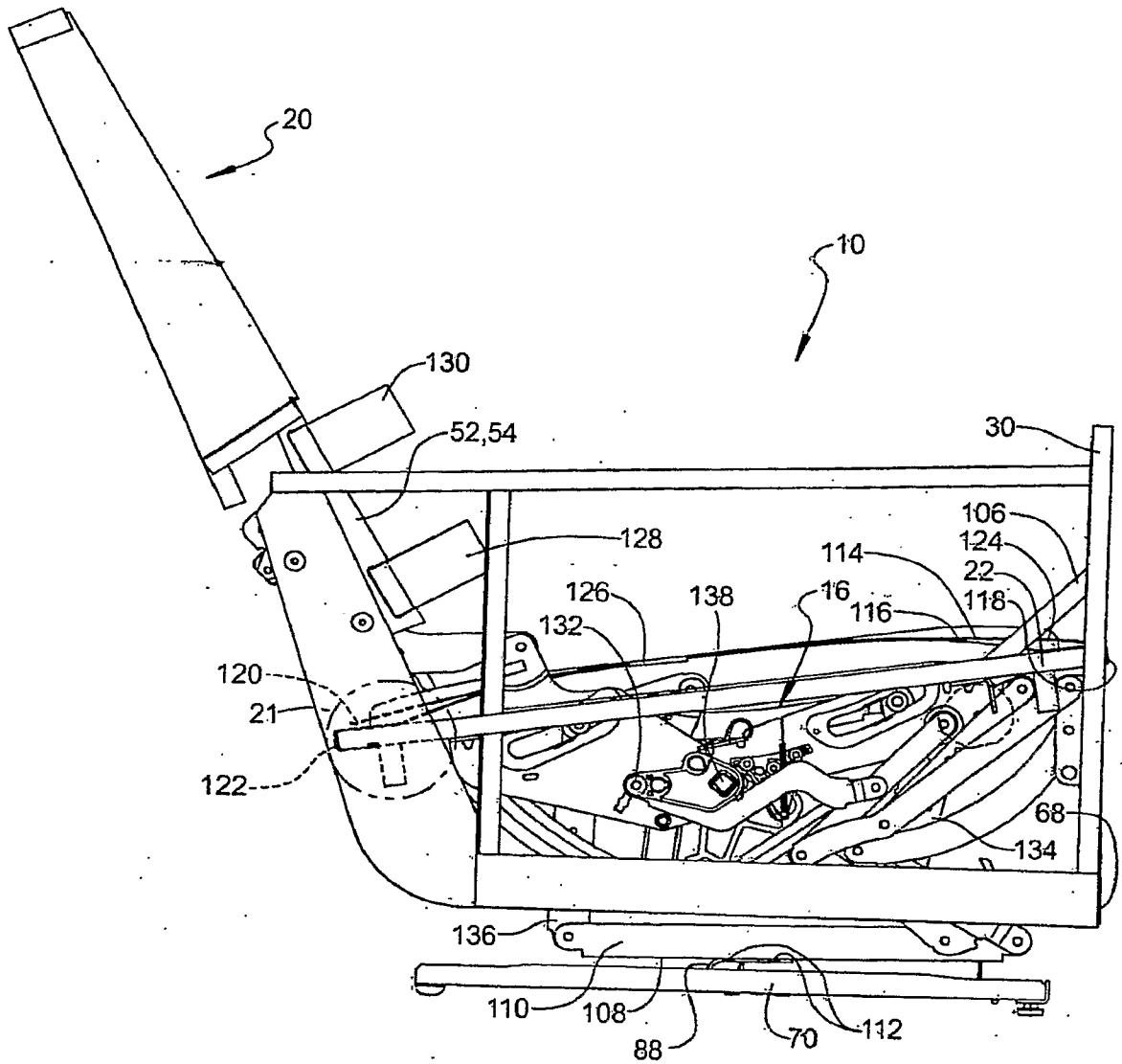

FIG 3

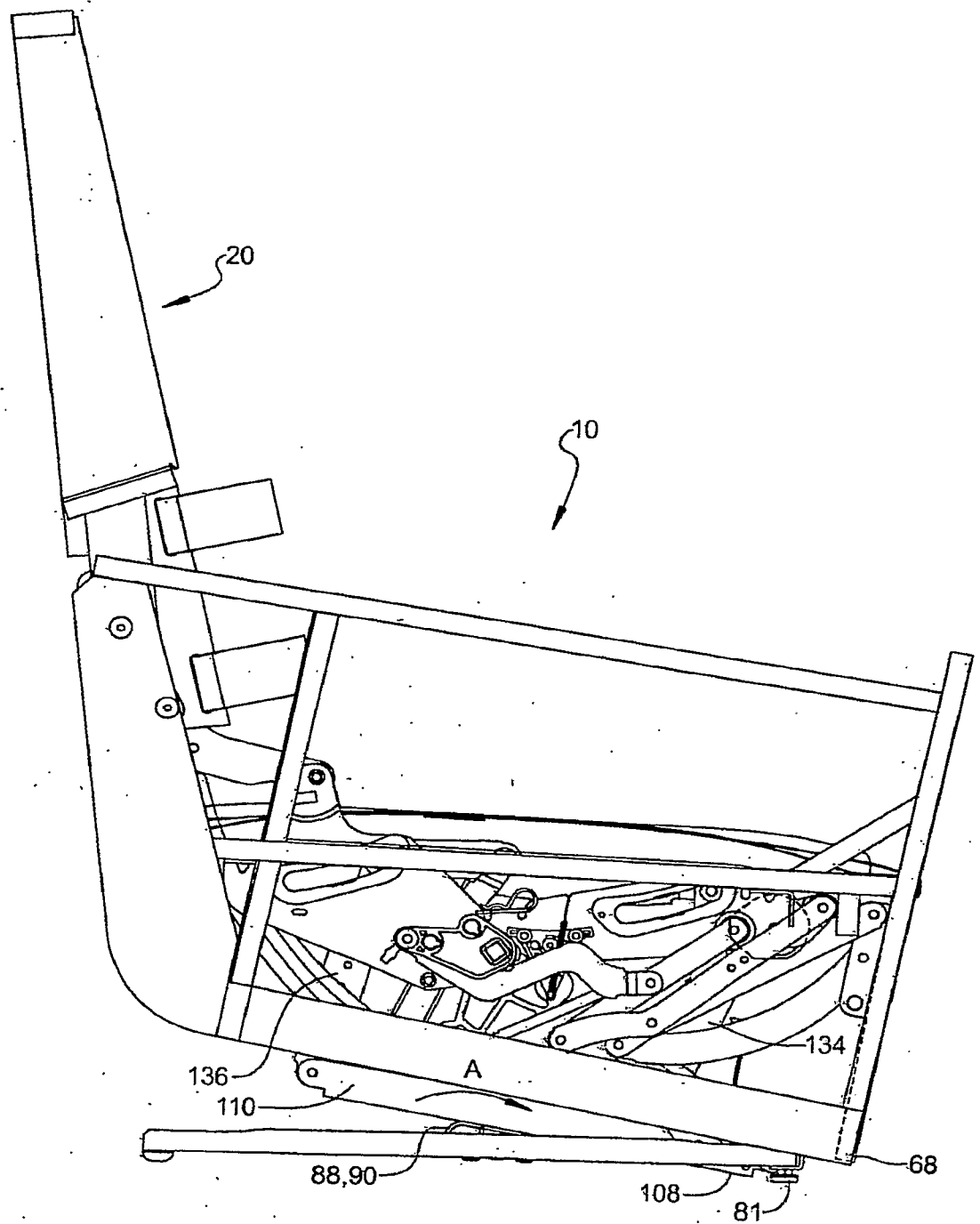
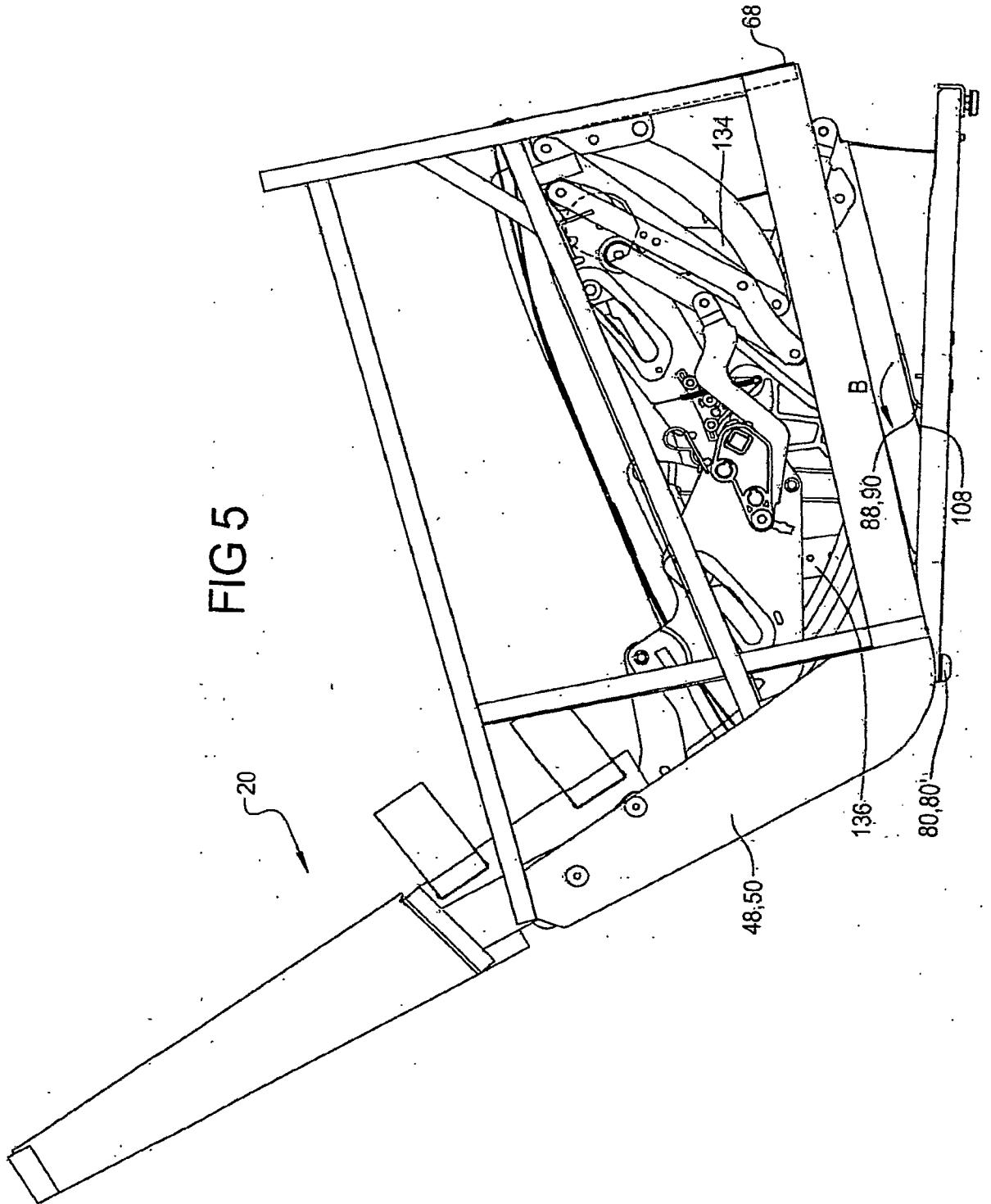
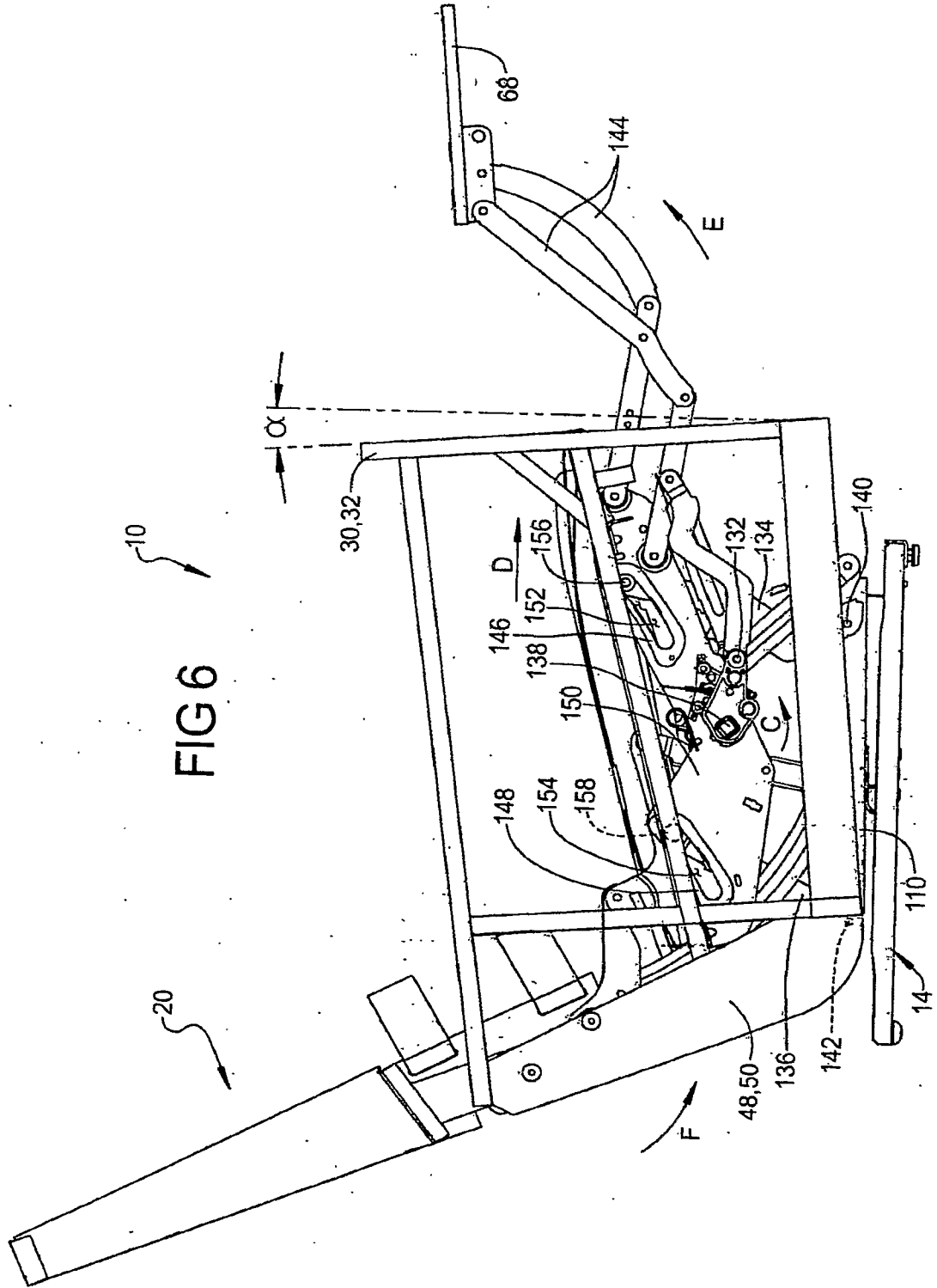

FIG 4

5/27



6/27



7/27

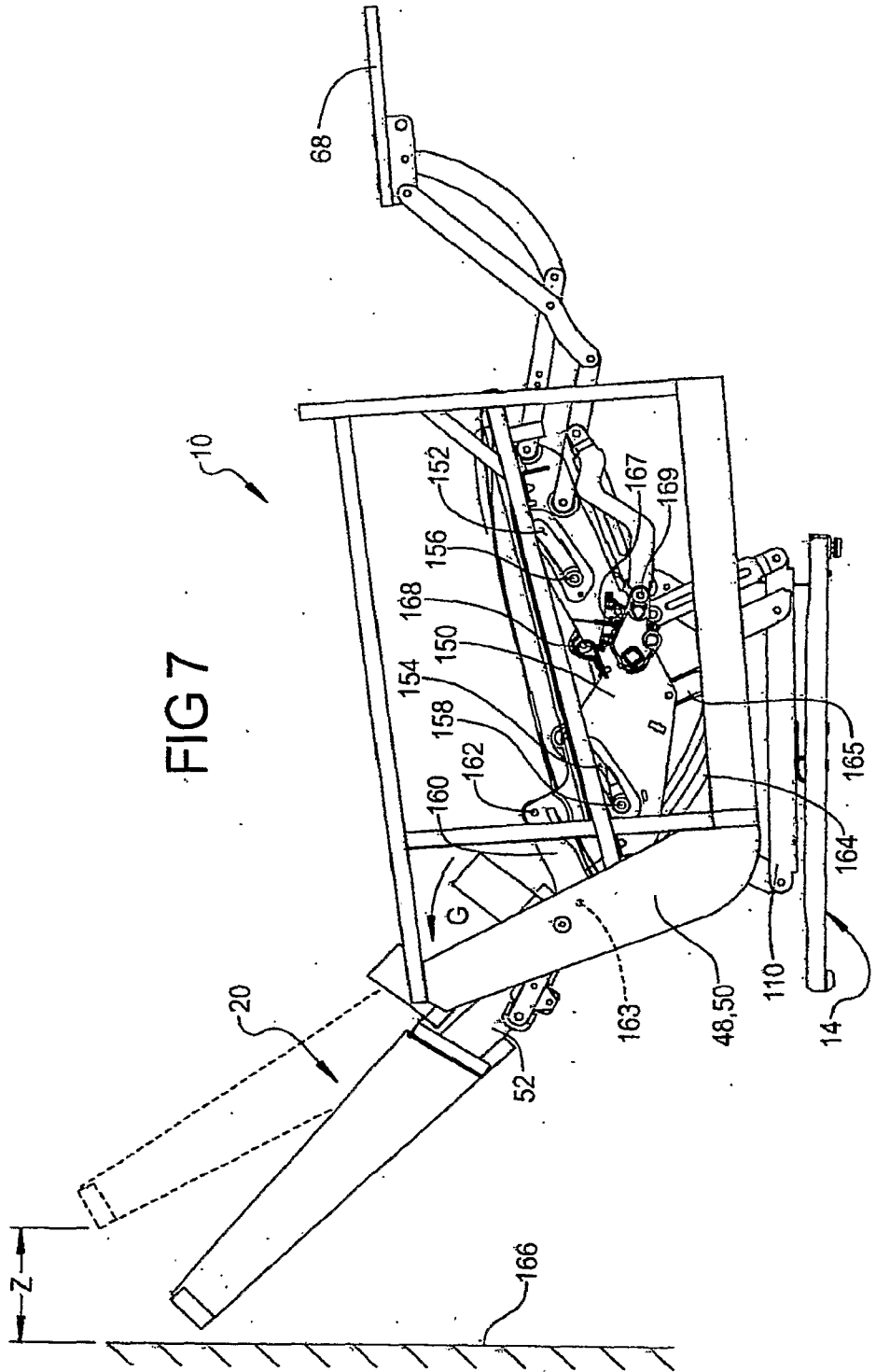

8/27

FIG 8

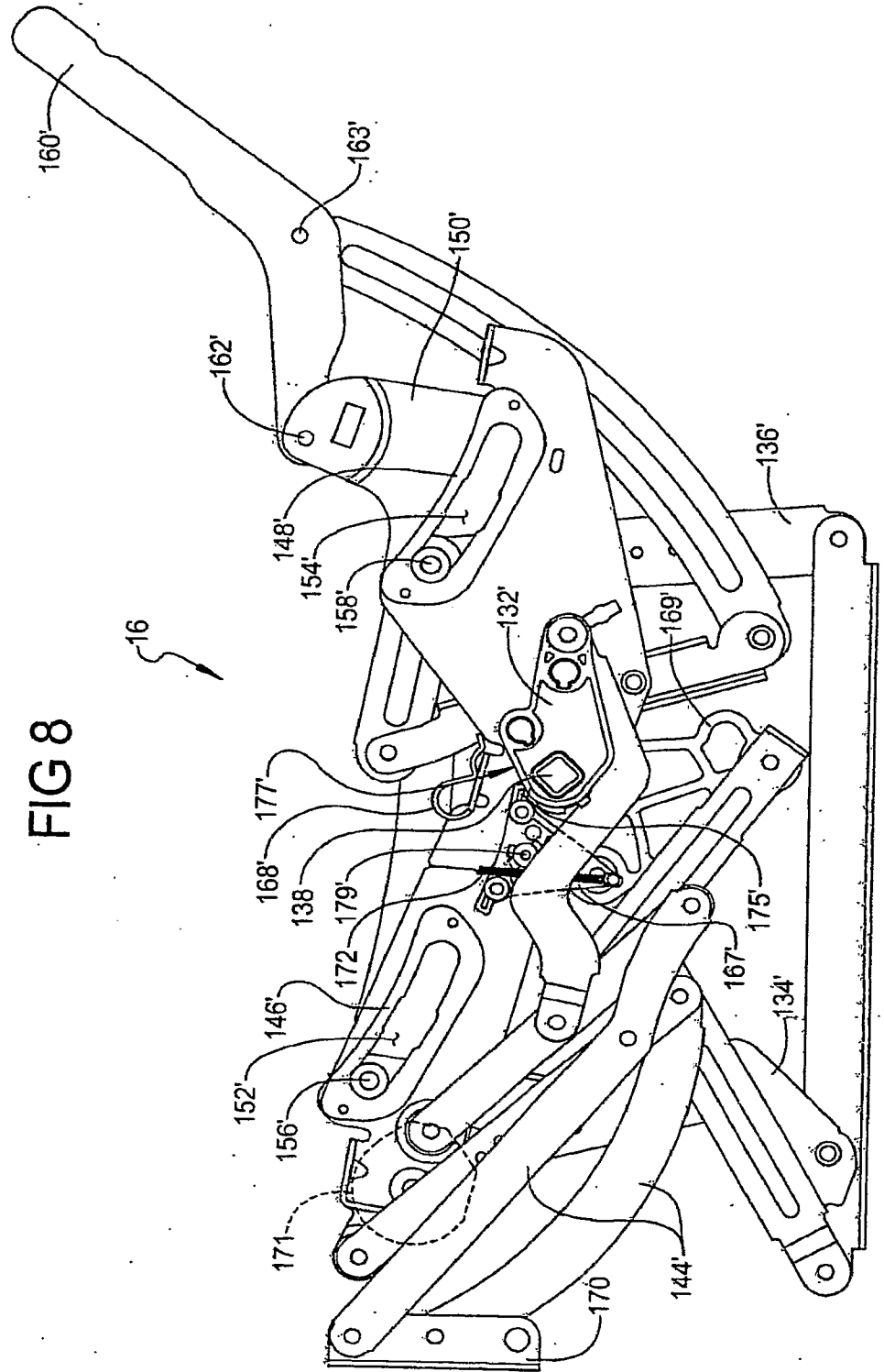

9/27

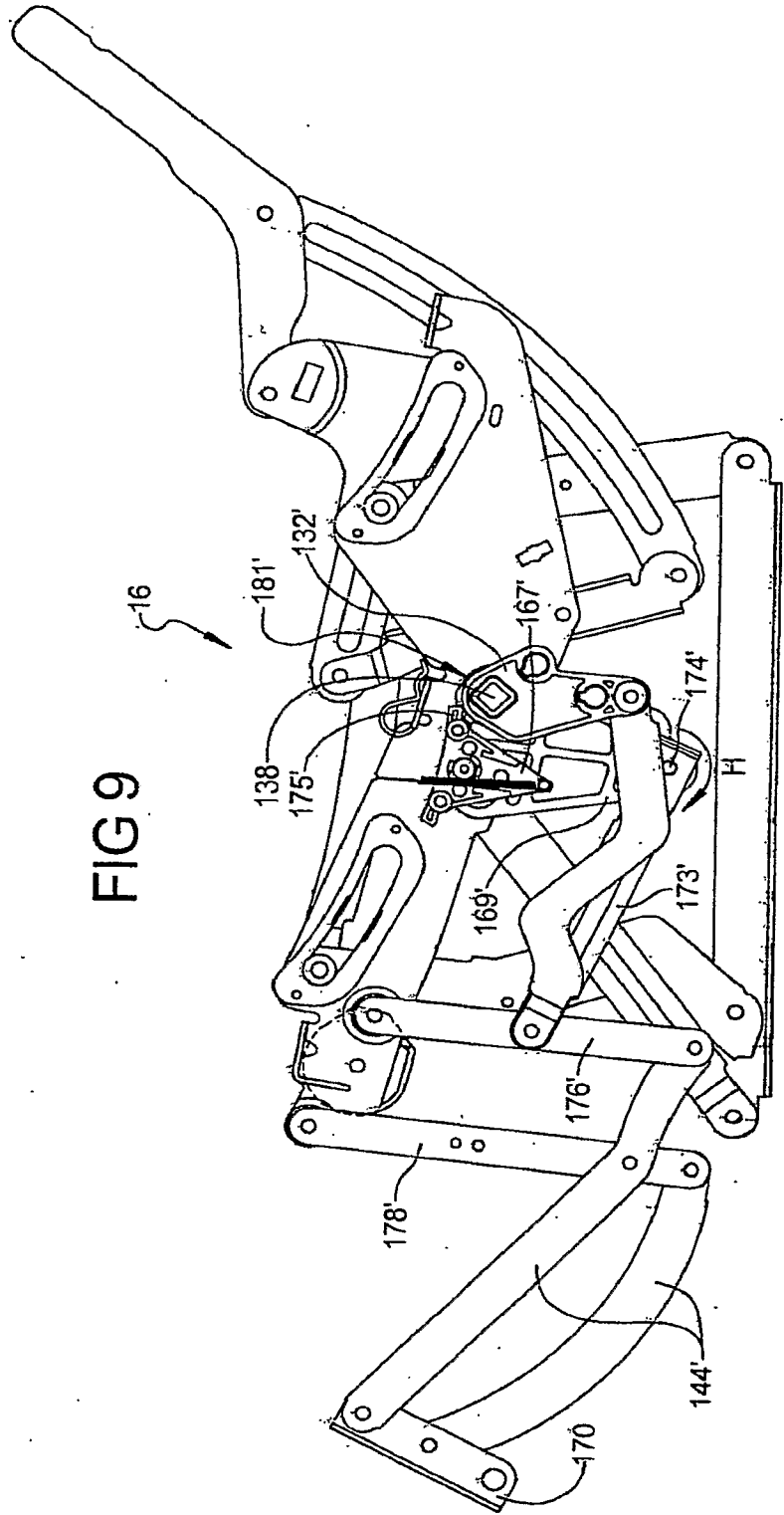
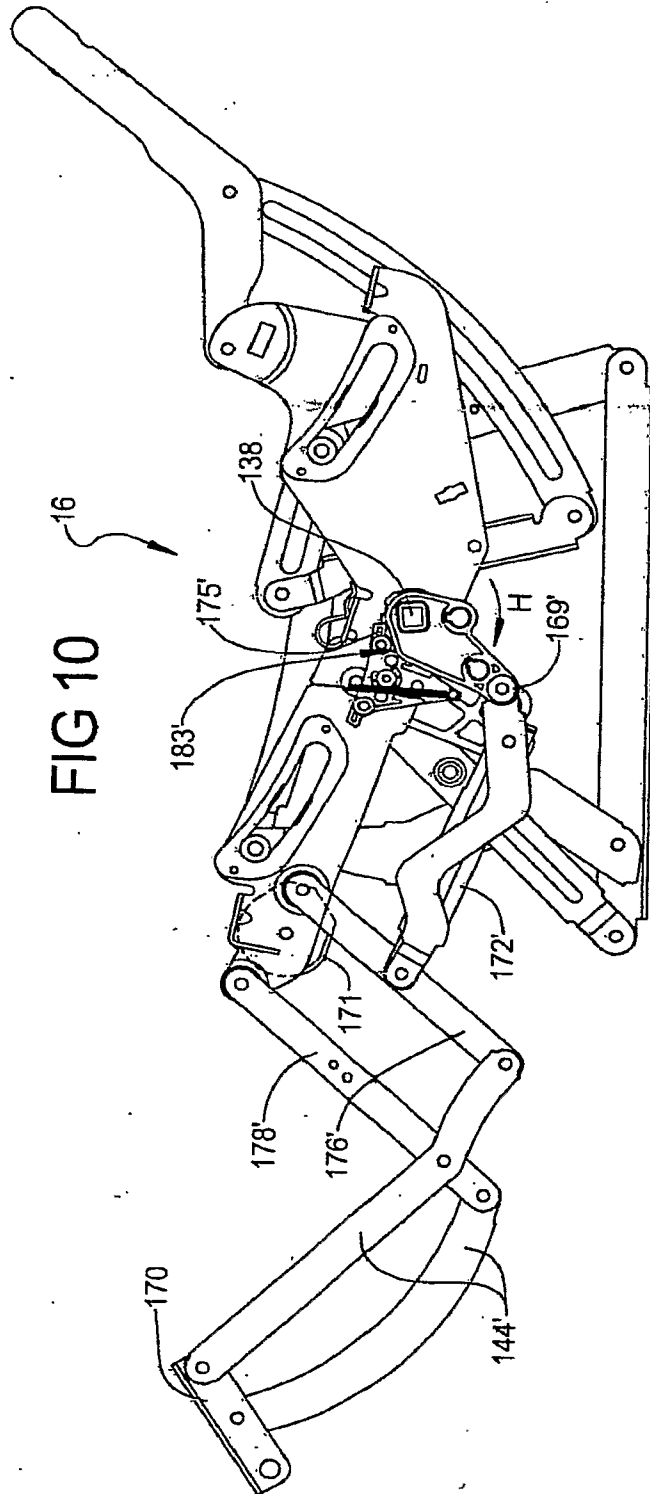

FIG 9

10/27



11/27

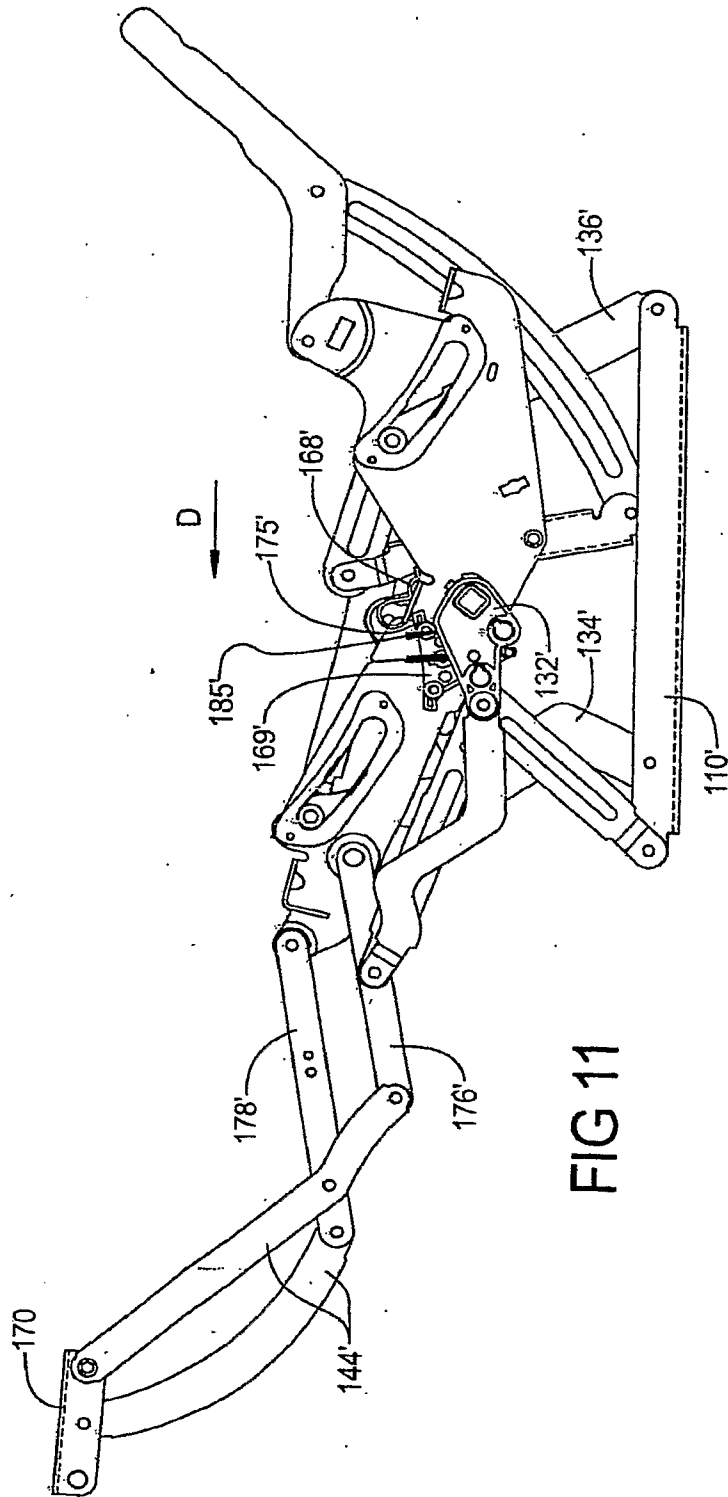

FIG 11

12/27

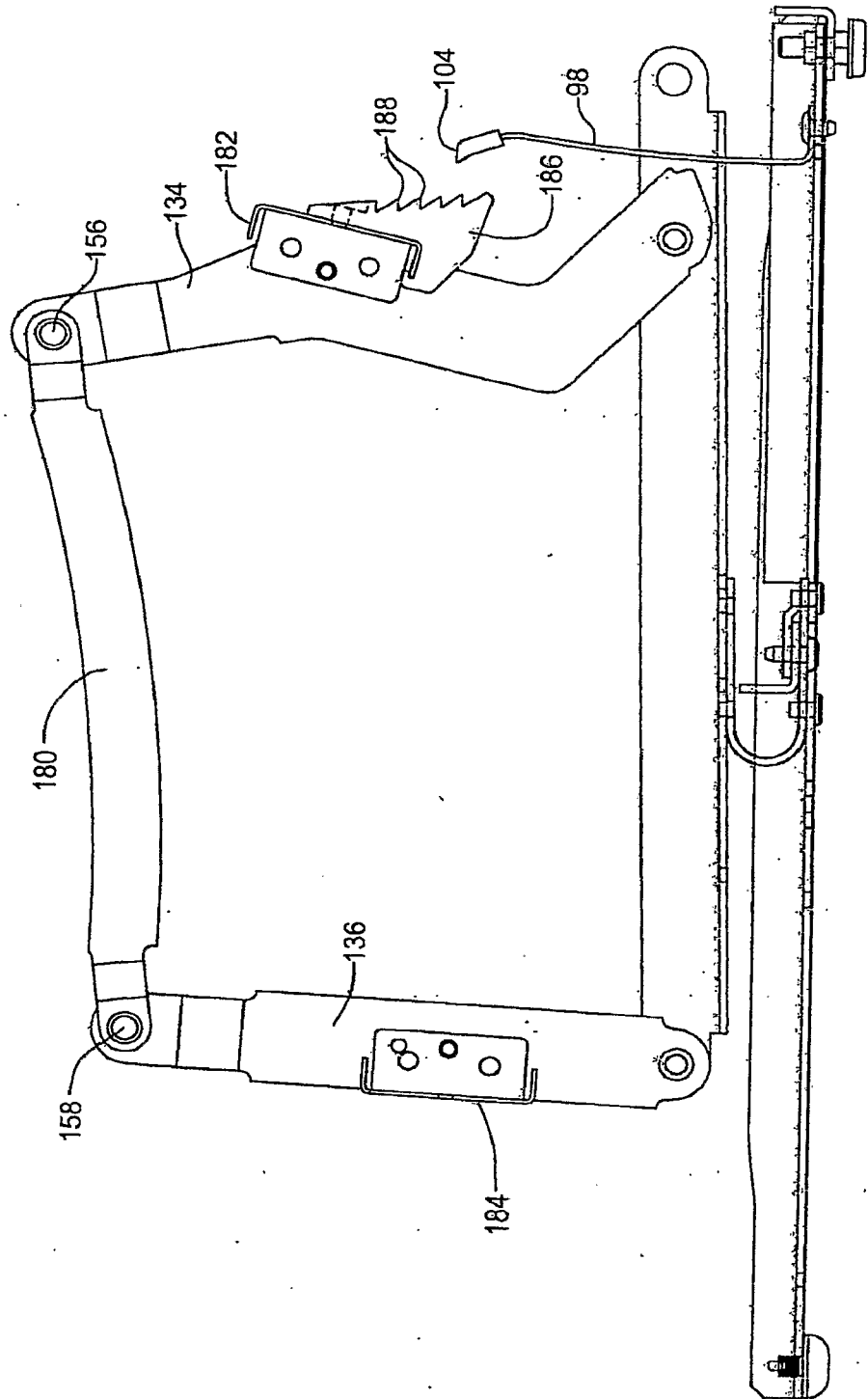

FIG 12

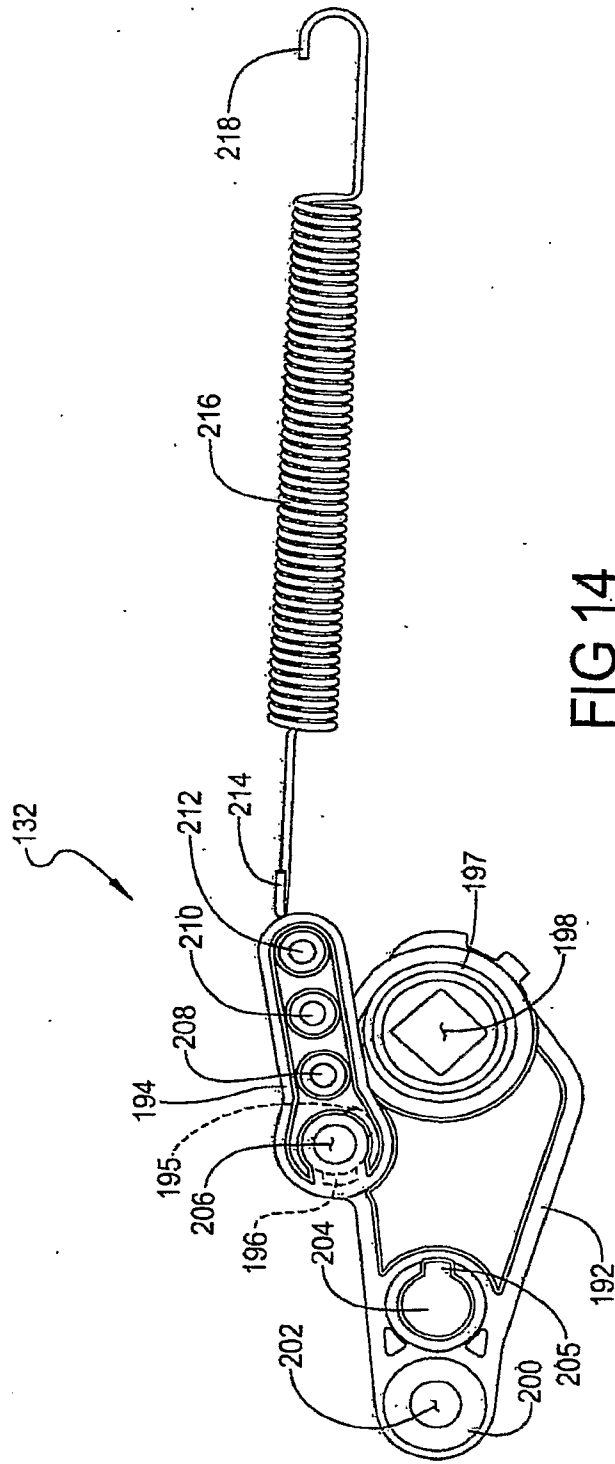
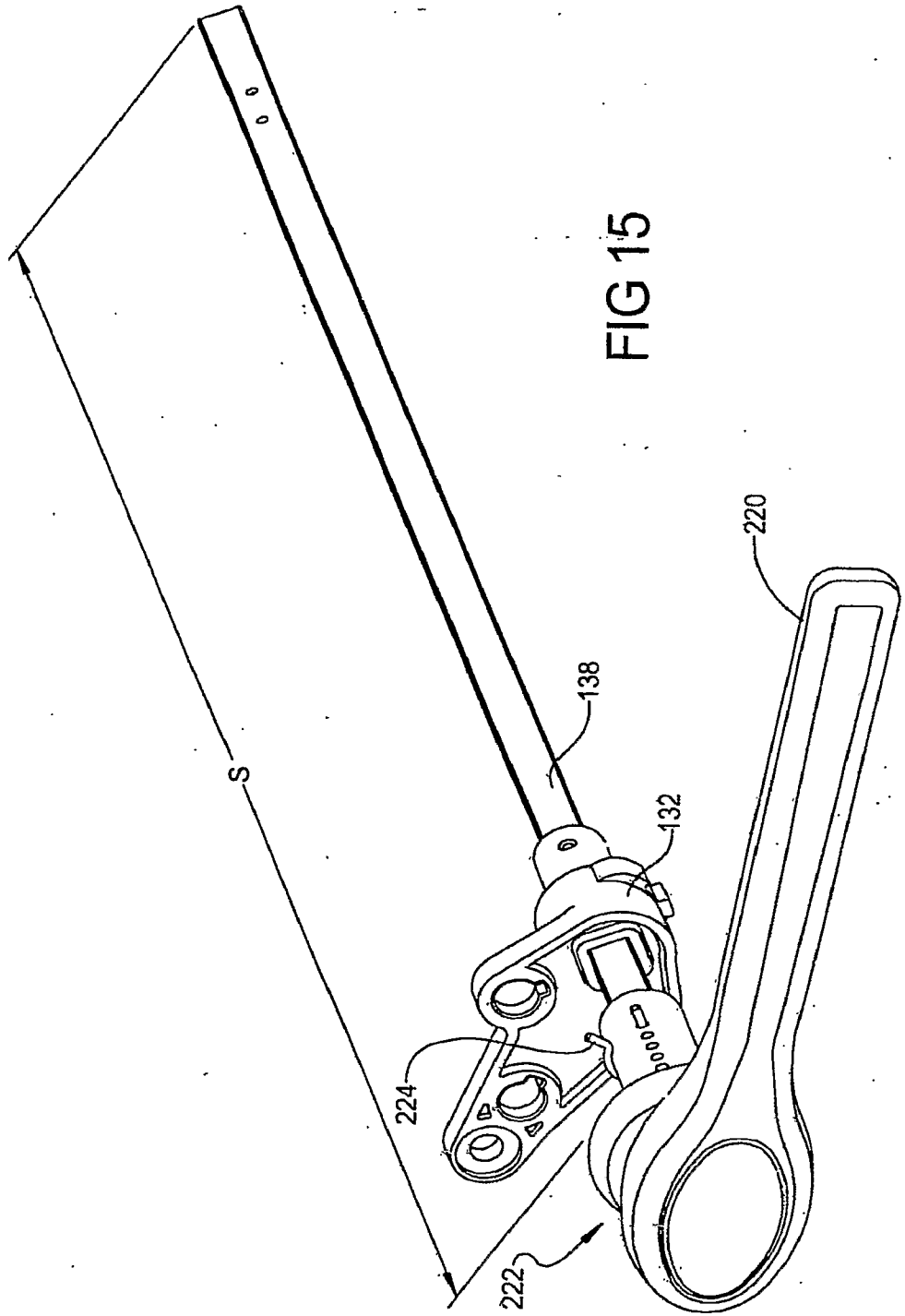

FIG 14



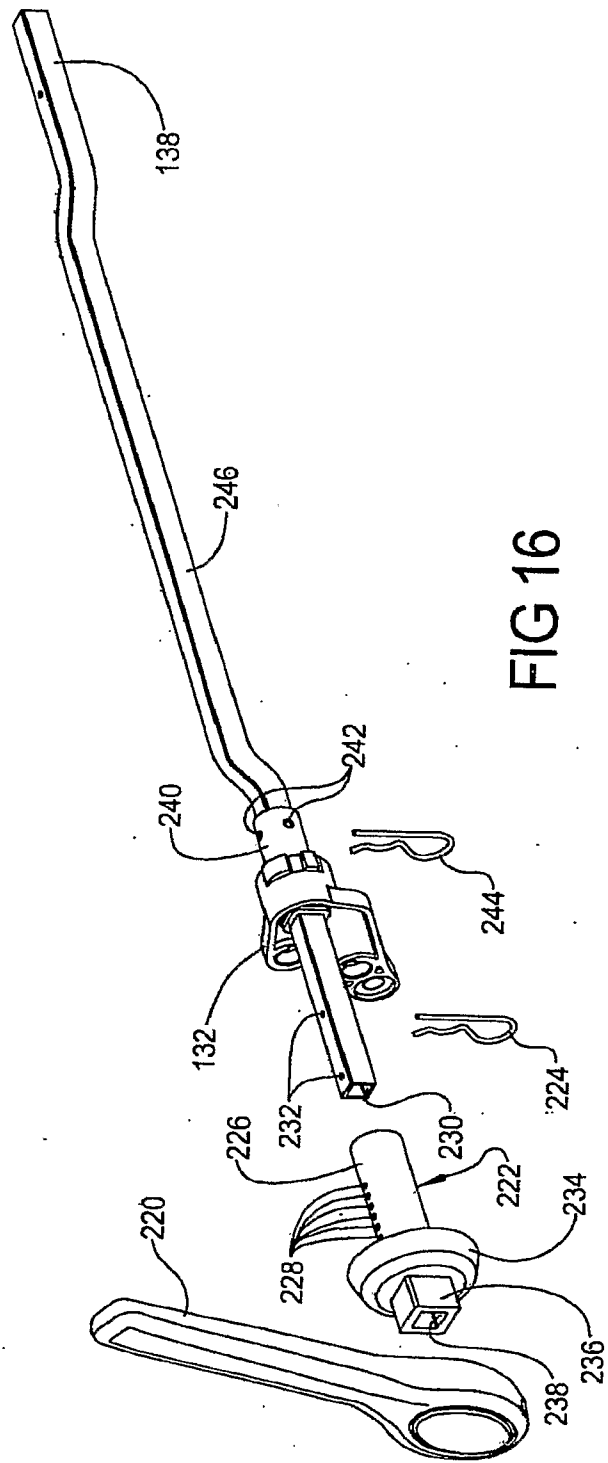

FIG 16

FIG 17

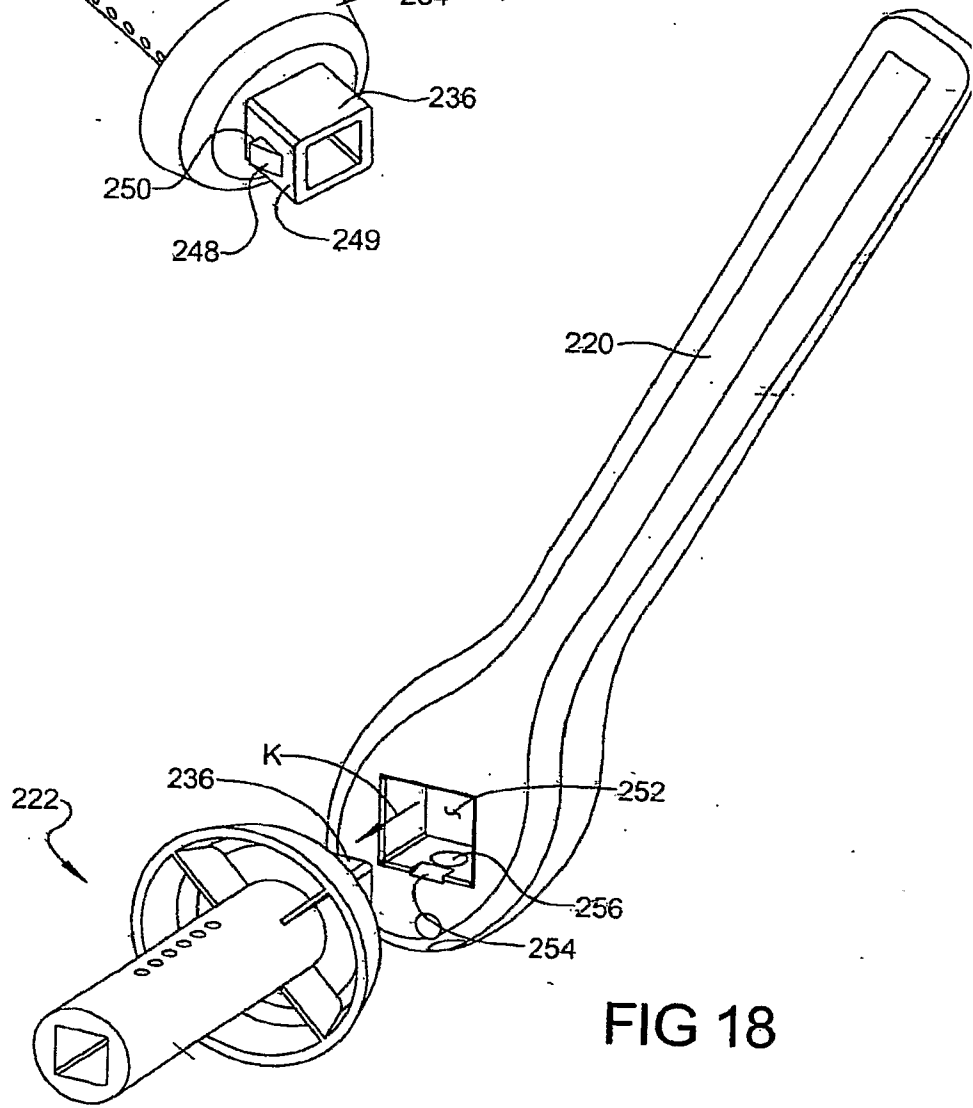
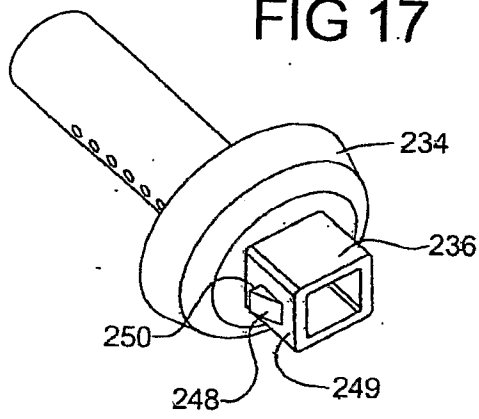

FIG 18

18/27

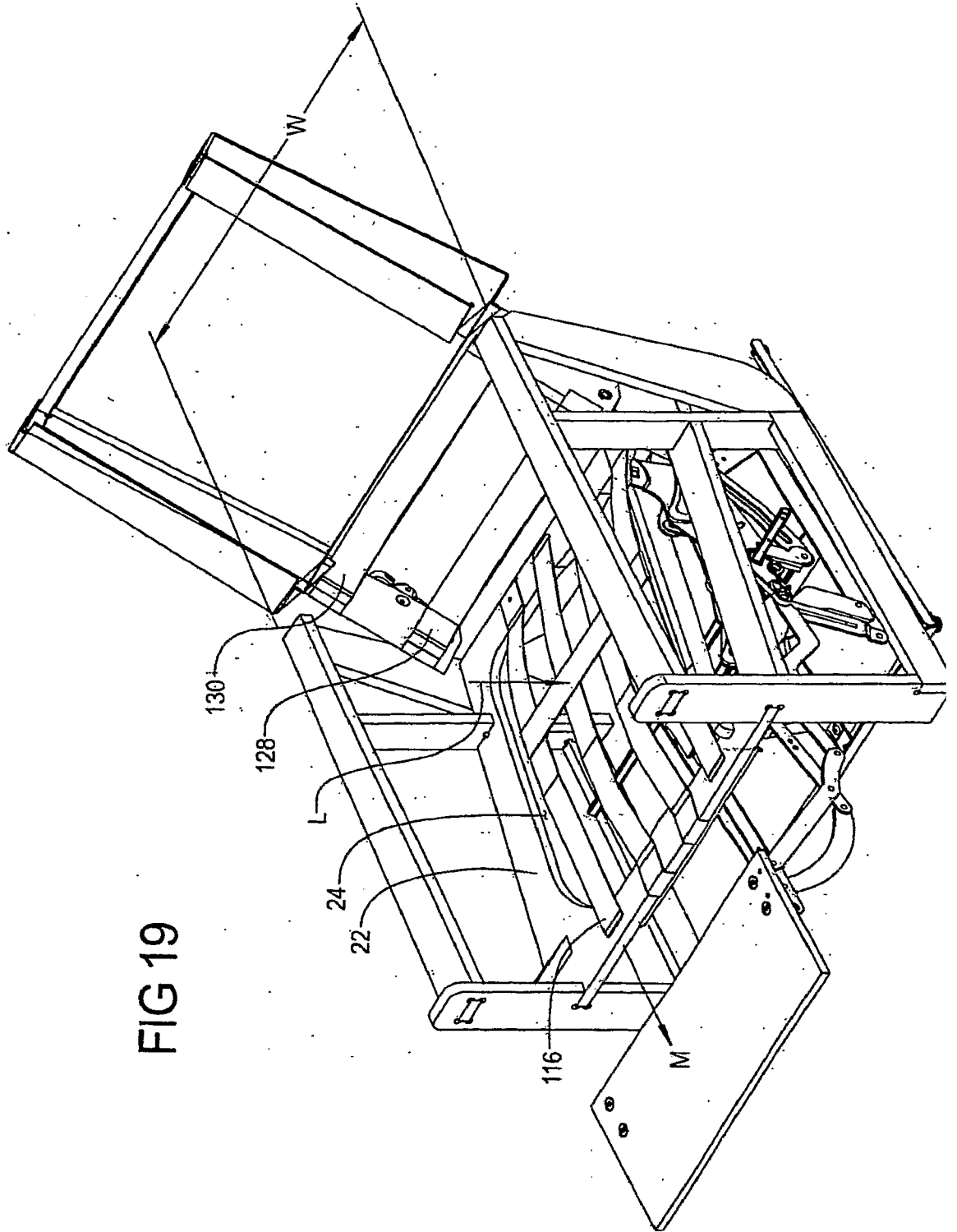

FIG 19

19/27

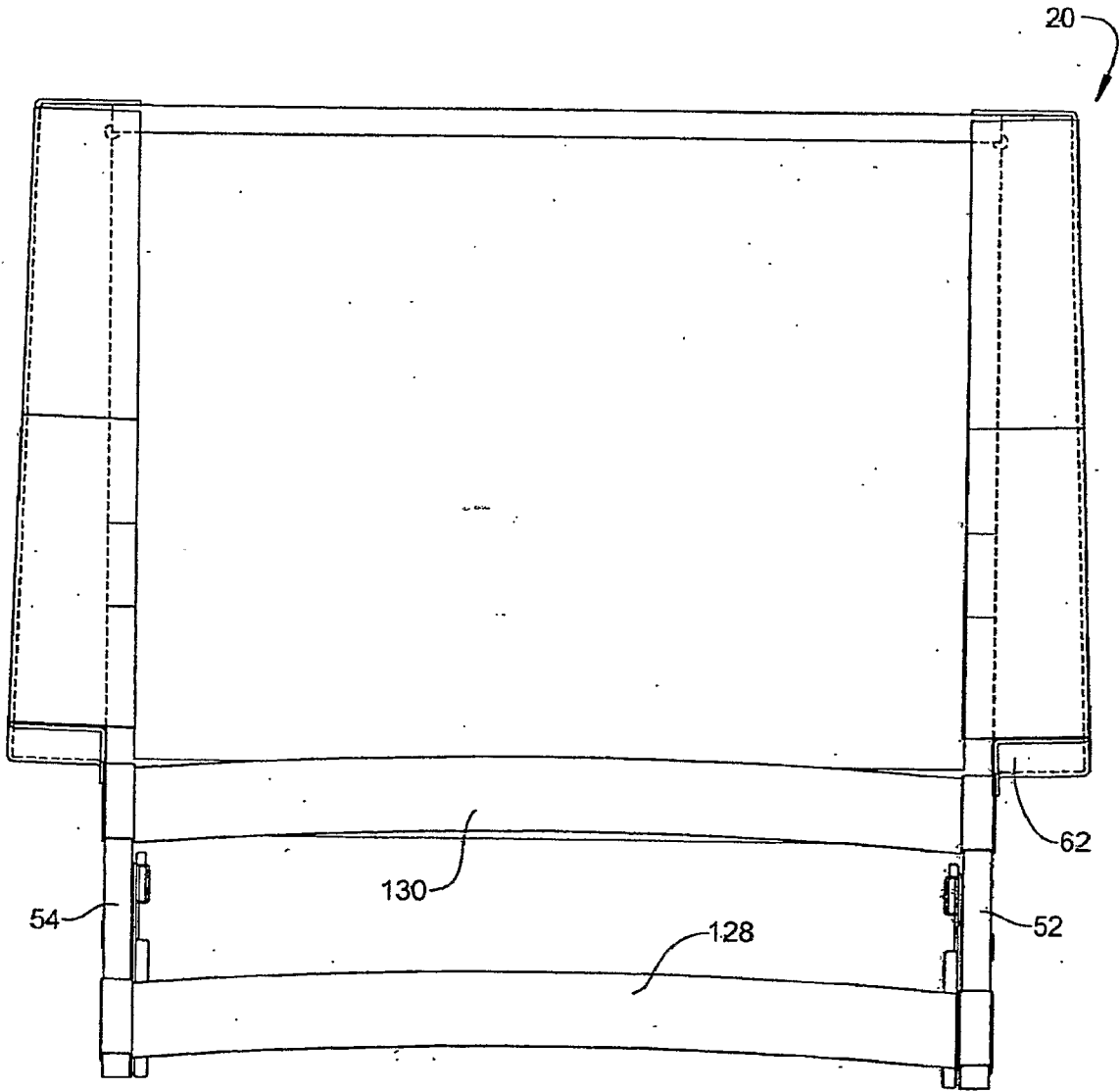

FIG 20

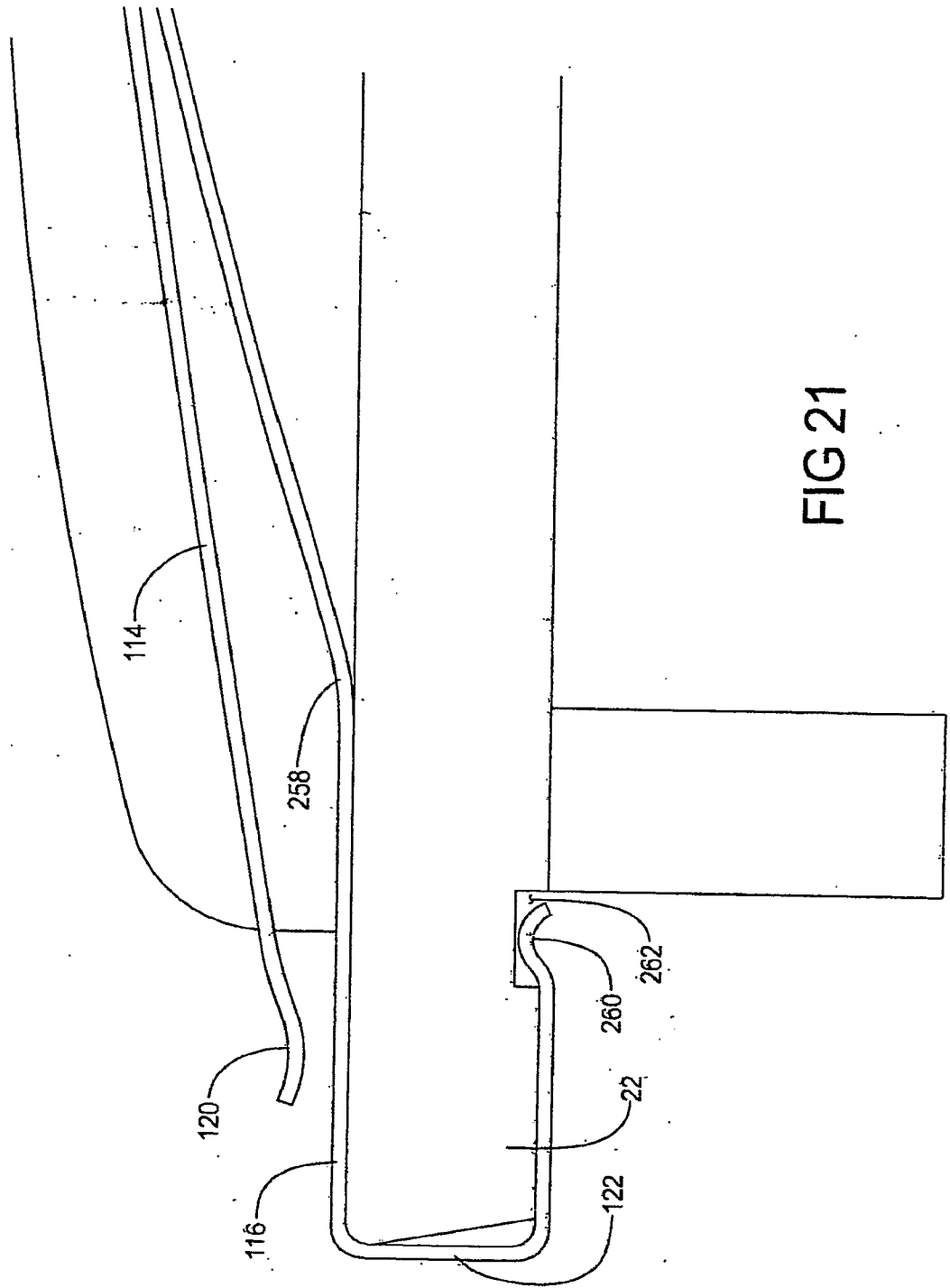

FIG 21

21/27

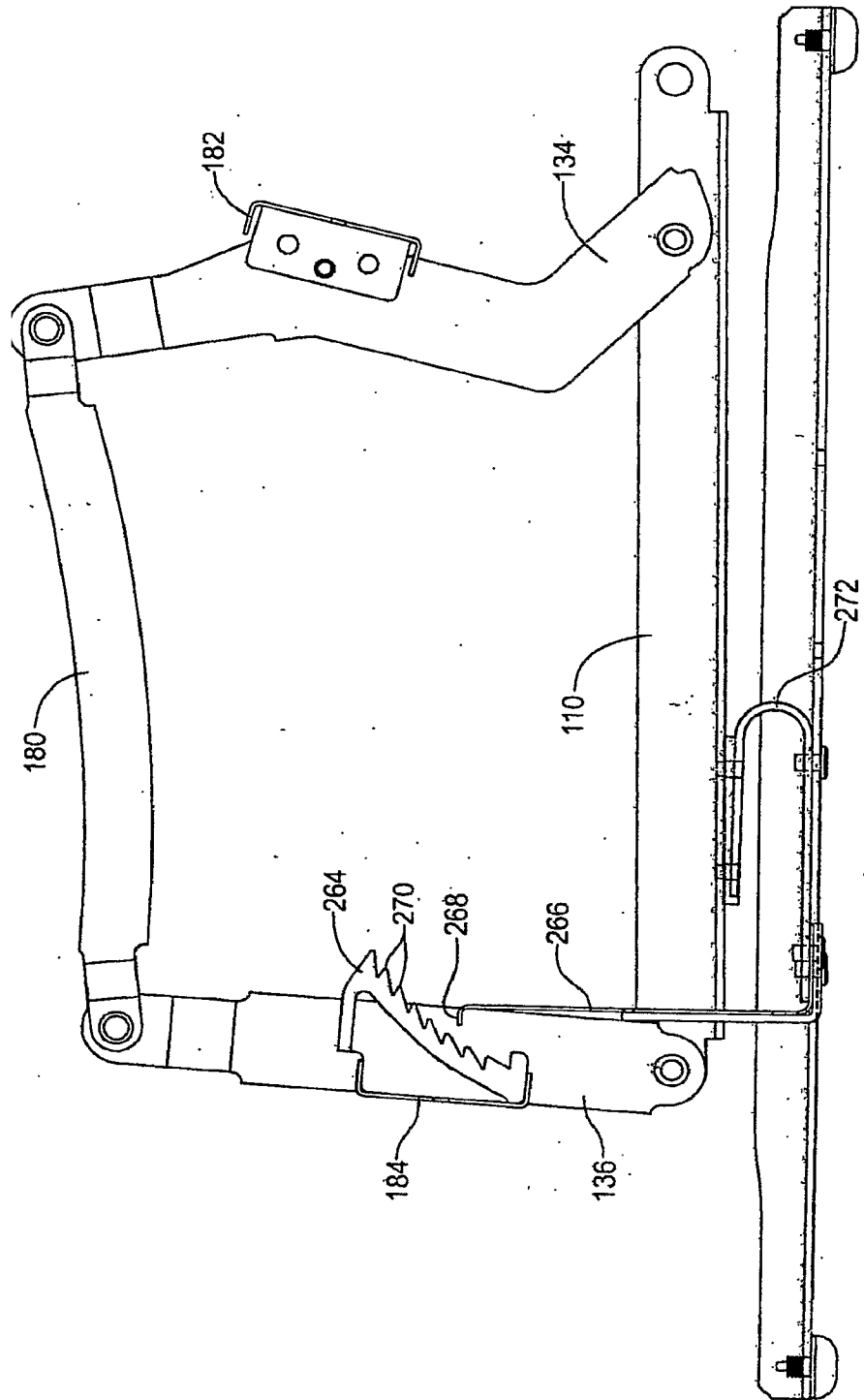

FIG 22

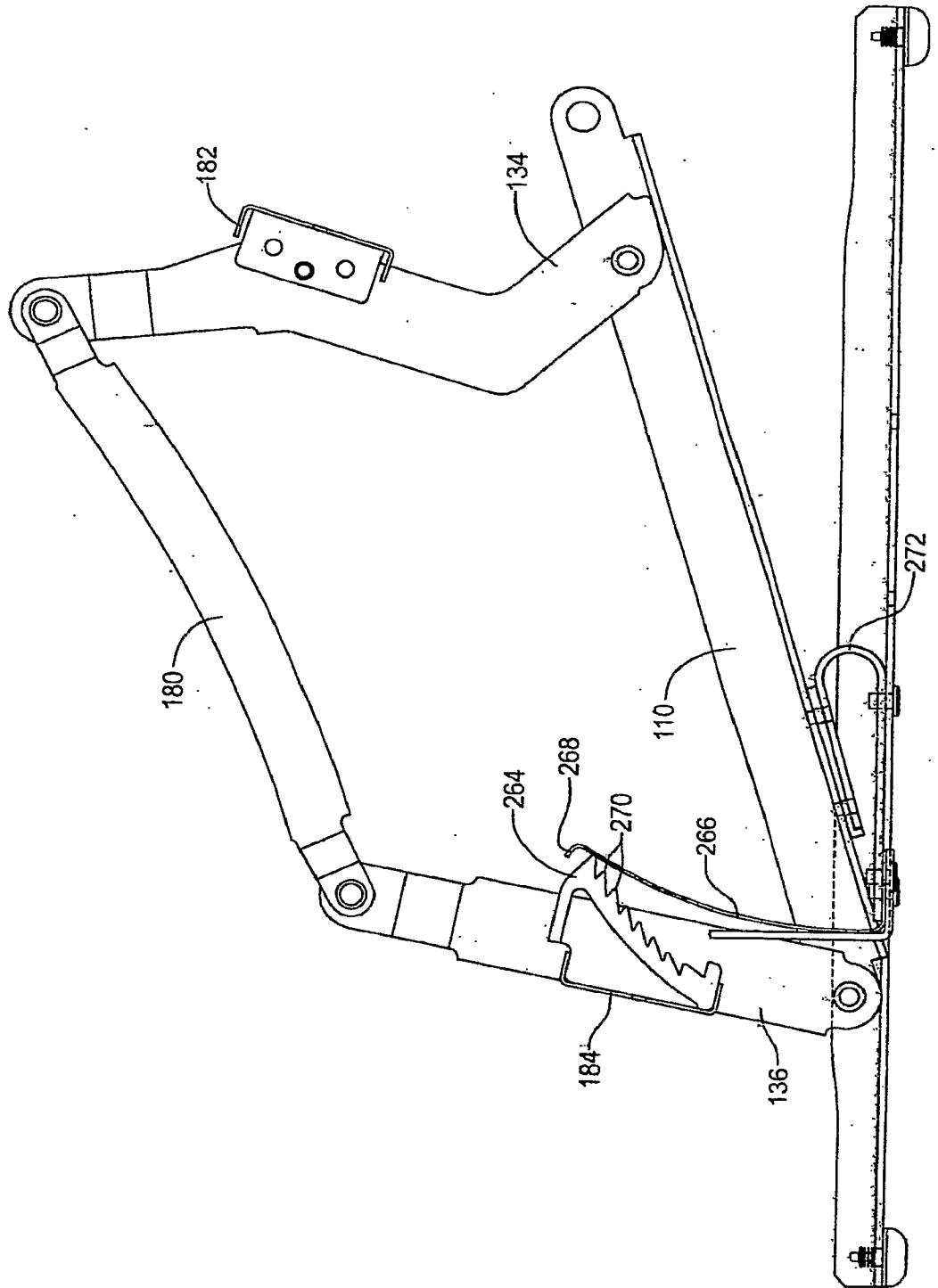

FIG 23

23/27

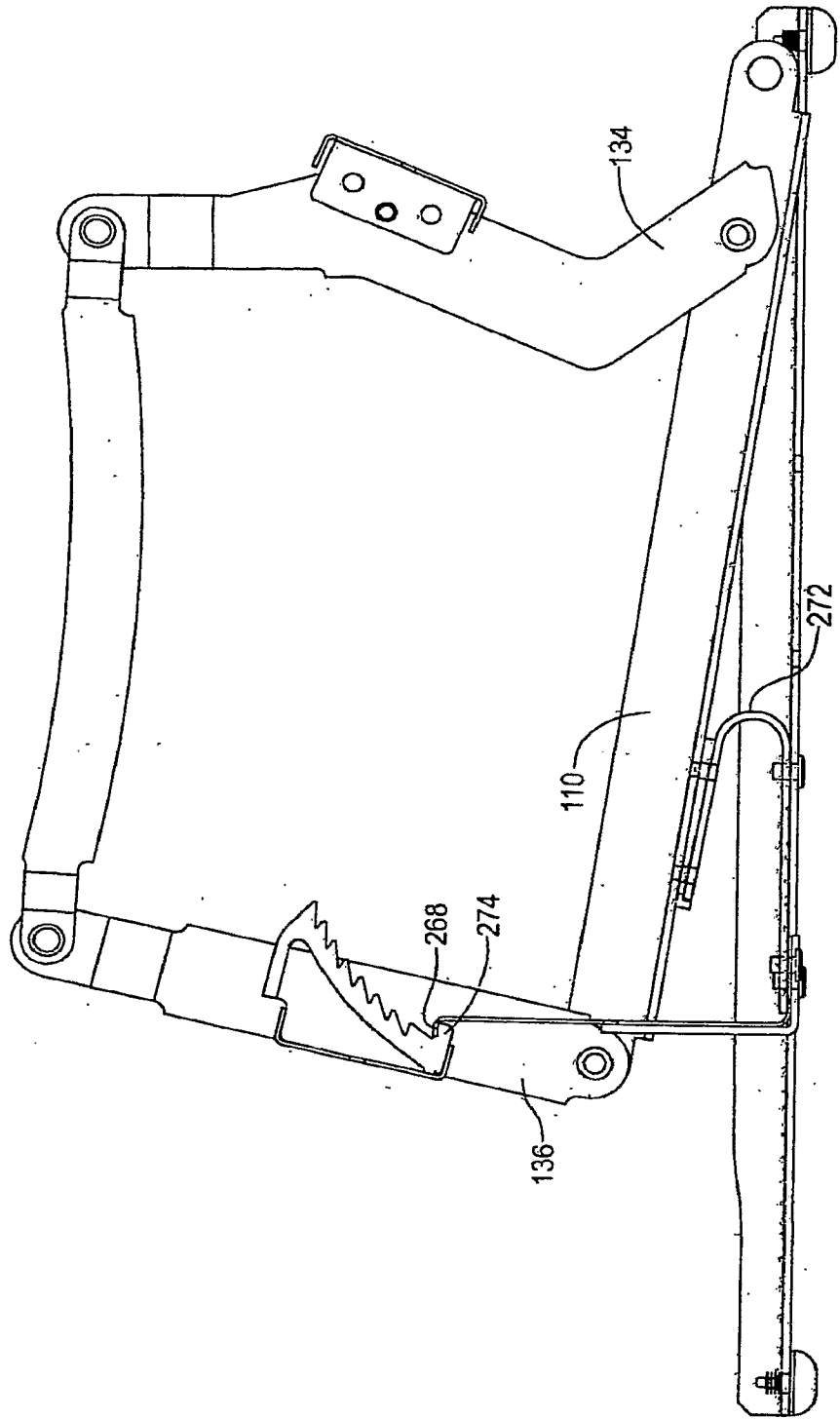

FIG 24

26/27

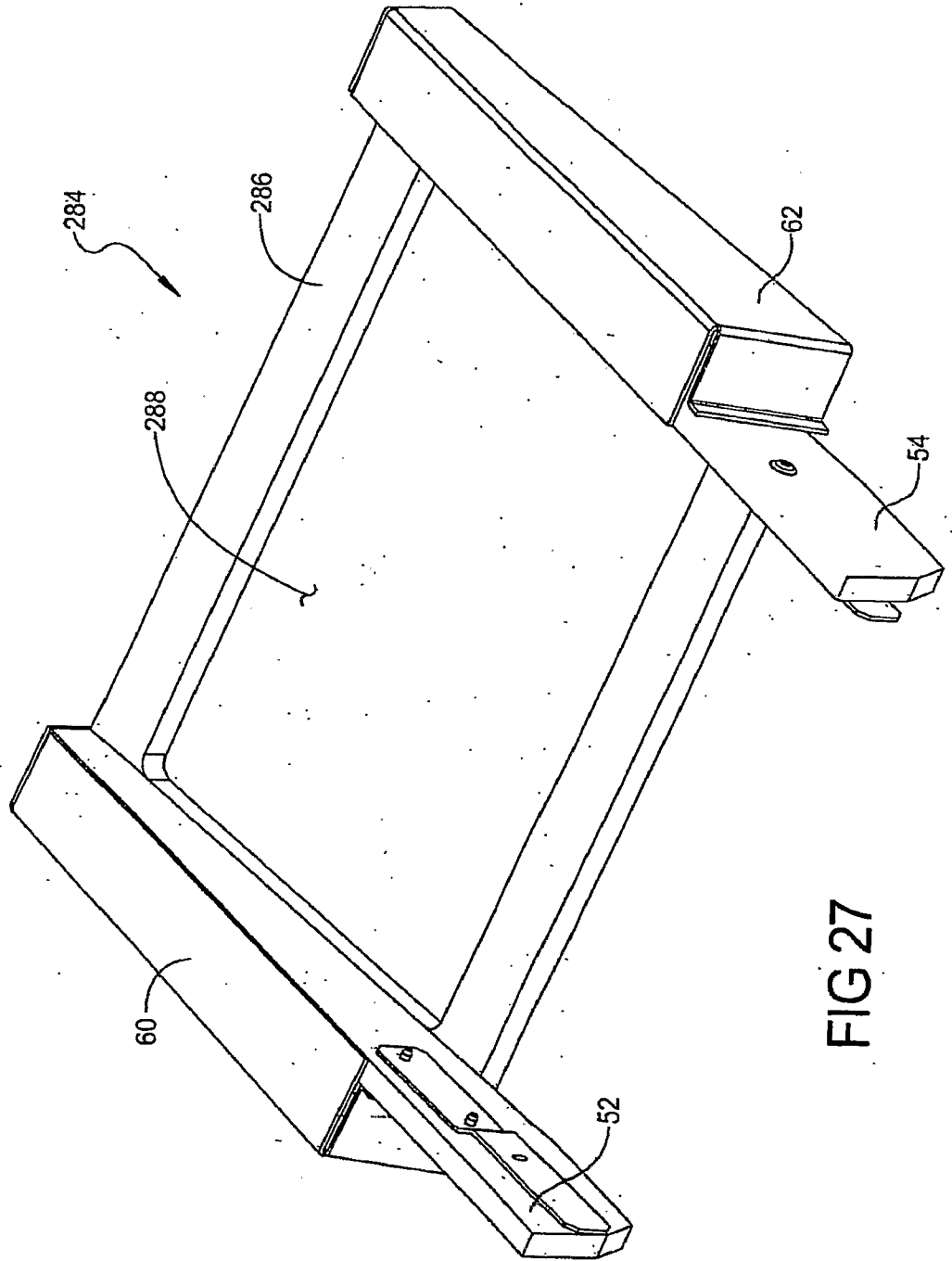

FIG 27

27/27

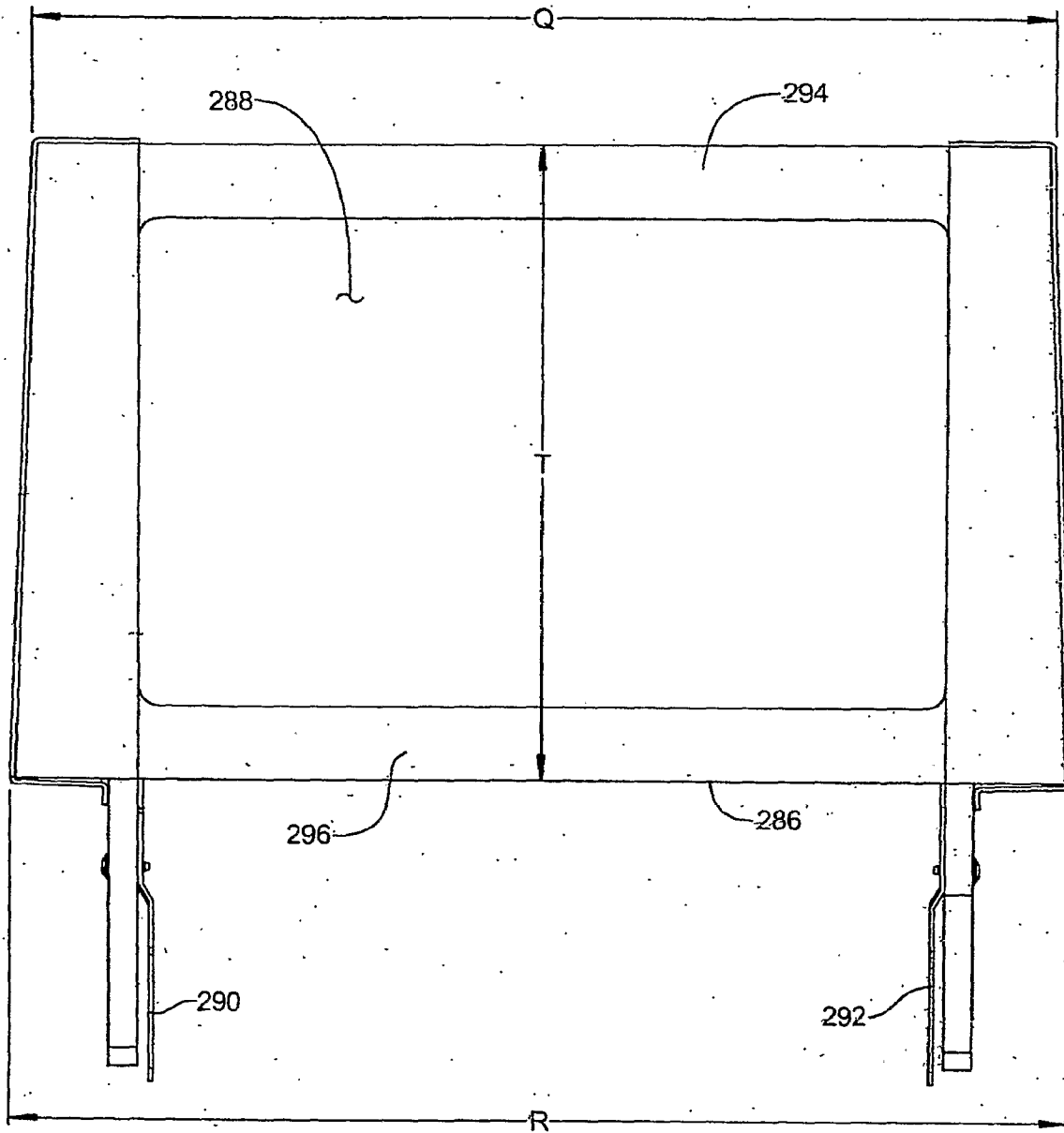

FIG 28