

(21) Application No: **2303715.3**
 (22) Date of Filing: **14.03.2023**
 (30) Priority Data:
 (31) **2208141** (32) **01.06.2022** (33) **GB**

(51) INT CL:
E06B 7/10 (2006.01) **E06B 7/02** (2006.01)
F24F 13/18 (2006.01)
 (56) Documents Cited:
GB 2571072 A **GB 2299664 A**
GB 2276235 A

(71) Applicant(s):
Glazpart Limited
21b Wildmere Road, Wildmere Industrial Estate,
Banbury, Oxfordshire, OX16 3JU, United Kingdom
 (72) Inventor(s):
Mark O'Mahoney
Lewis Smith
 (74) Agent and/or Address for Service:
Boult Wade Tennant LLP
Salisbury Square House, 8 Salisbury Square,
LONDON, EC4Y 8AP, United Kingdom

(58) Field of Search:
 INT CL **E06B, F24F**
 Other: **SEARCH PATENT**

(54) Title of the Invention: **Vent for a window frame**
 Abstract Title: **Trickle vent with a frame that defines a slot**

(57) A trickle or background vent 100 for a window frame, where the trickle vent has a frame which defines a full perimeter of a slot in the window frame. The vent frame comprises a frame body 10 and a cover attachment 18. The vent also has a cover member 20 that has a frame attachment 28 which is pivotally attached to the cover attachment which may be a hinge. The cover member may be positioned in an open position to allow airflow through the vent; or a closed position where airflow is blocked, and the cover member completely envelops the frame body. The cover member may be in the form of a single piece or several different portions where each portion may be independently movable. The vent frame also has window fixings 14, to attach the vent to a frame, where each fixing has a protrusion or peg with deformable arms. A window assembly comprising a window frame and the vent, and a method of fitting the vent are also disclosed.

Figure 2

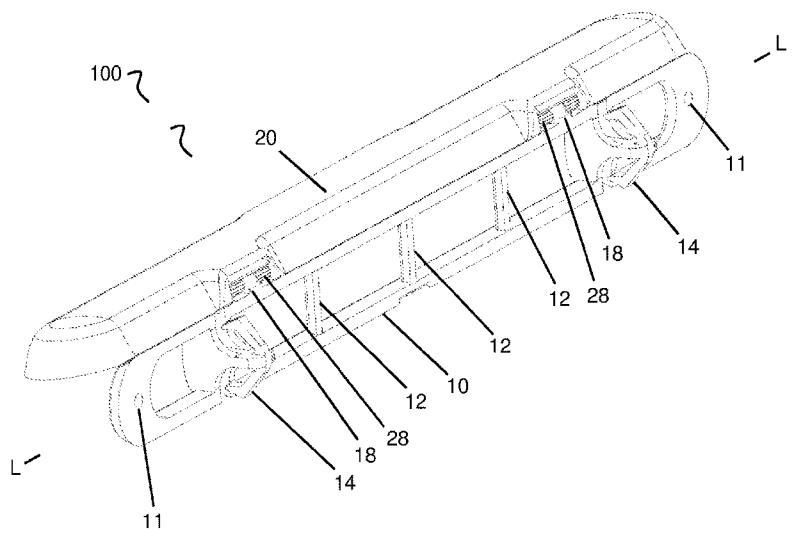

Figure 1

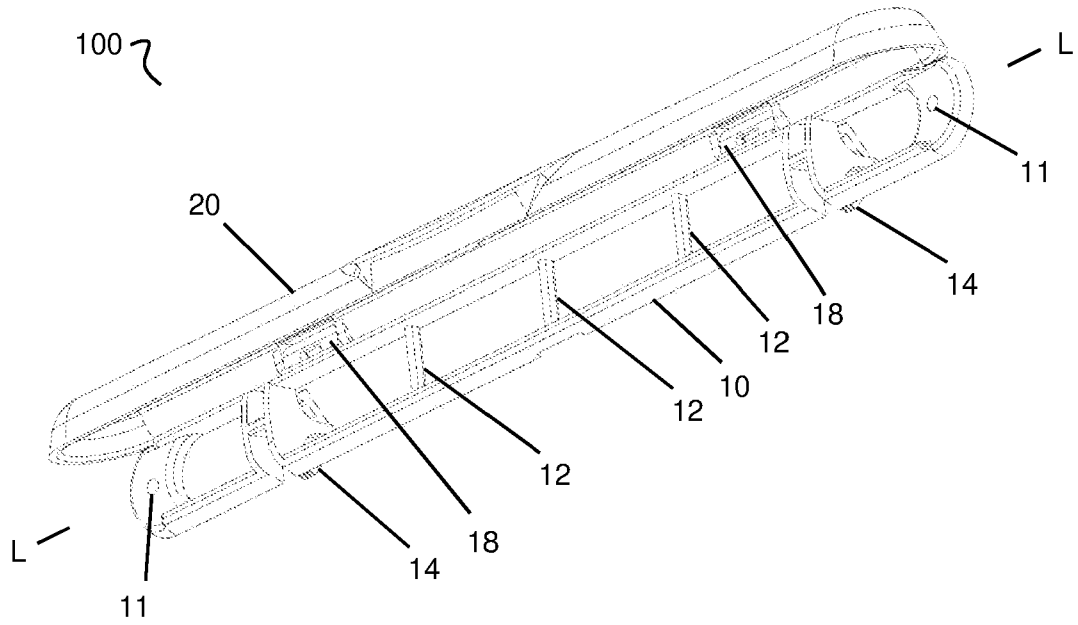

Figure 2

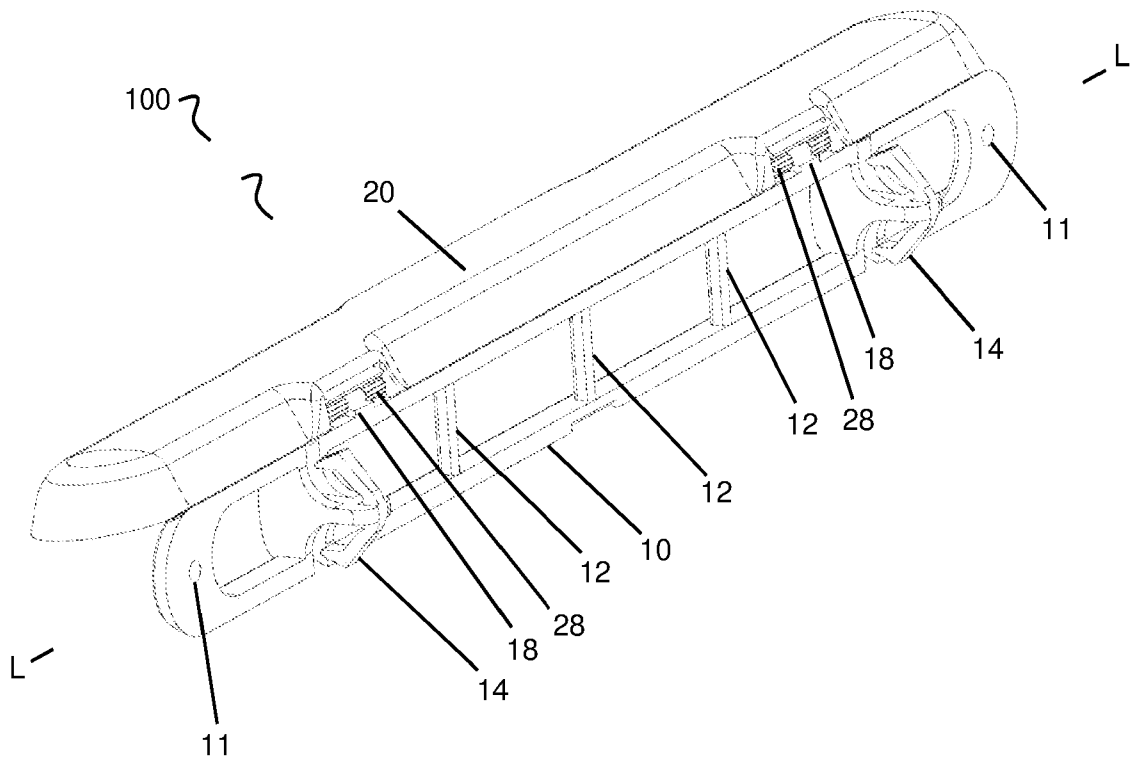

Figure 3

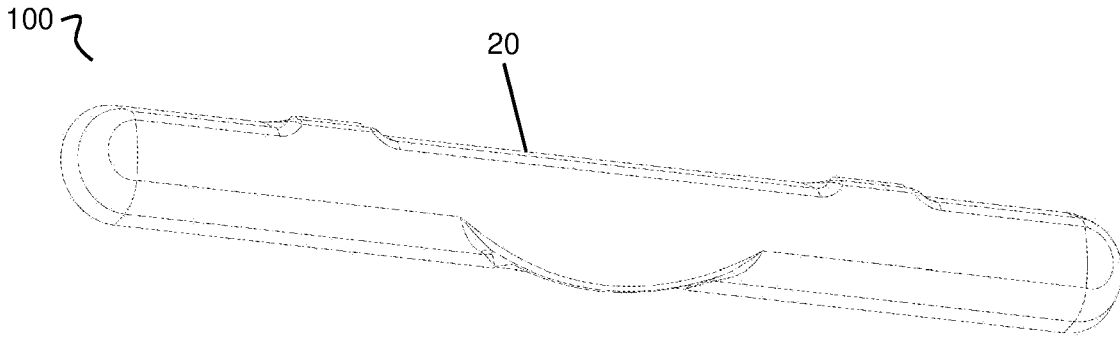

Figure 4

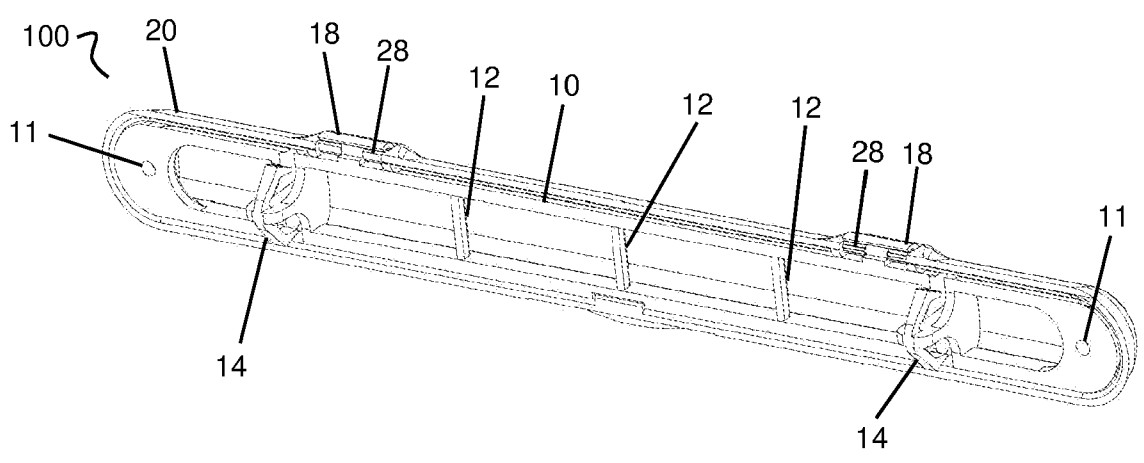

Figure 5

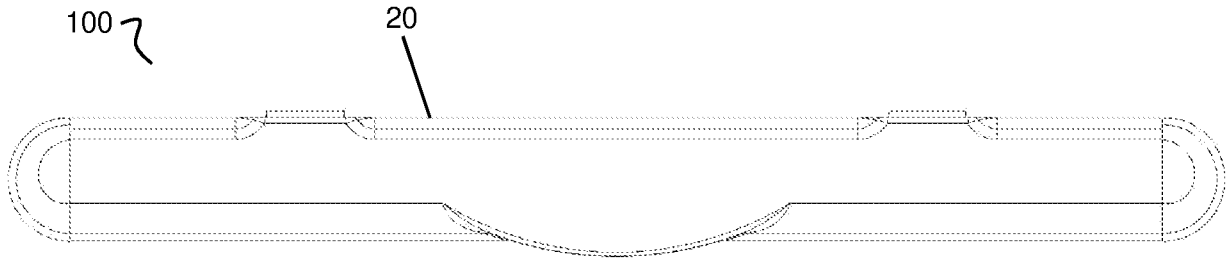

Figure 6

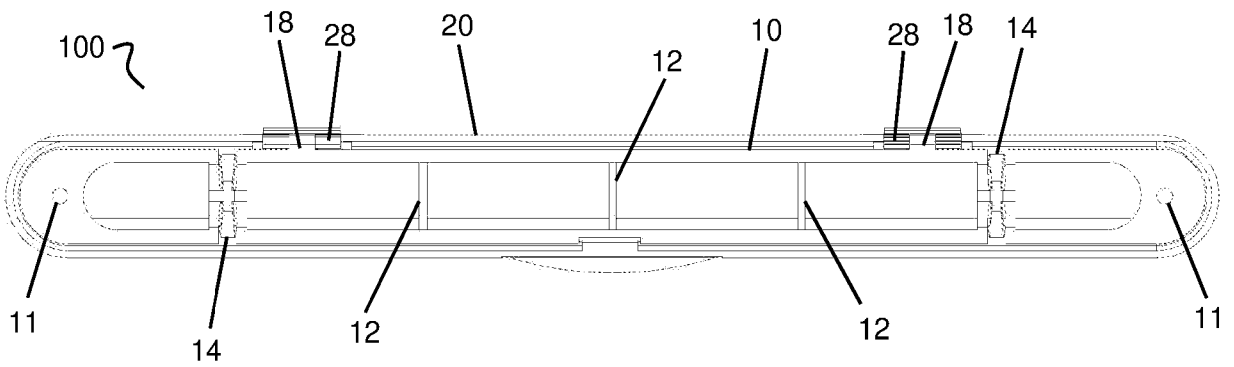

Figure 7

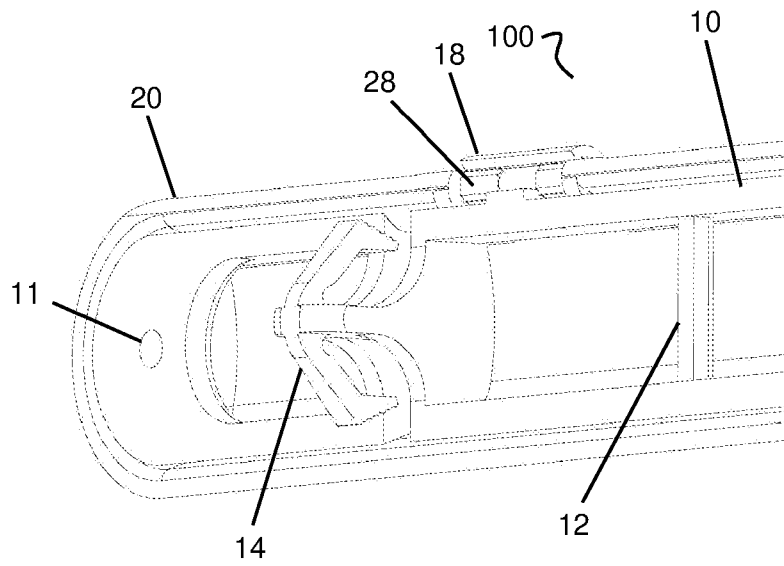

Figure 8

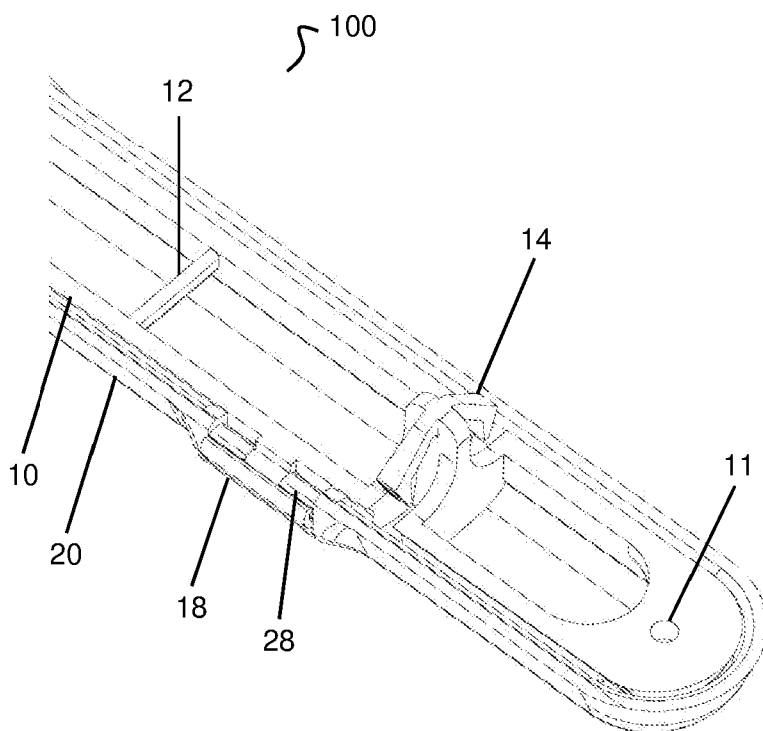
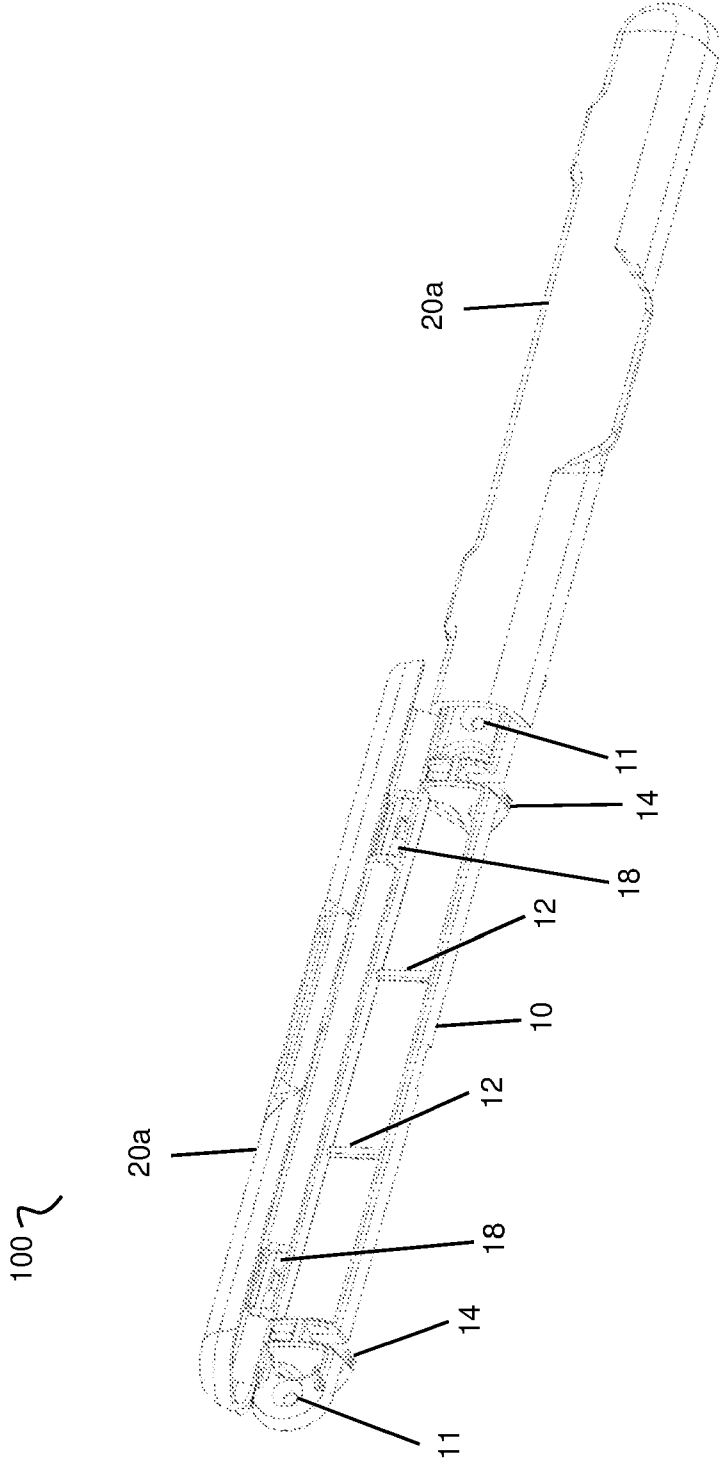

Figure 9



100 ~

Figure 10

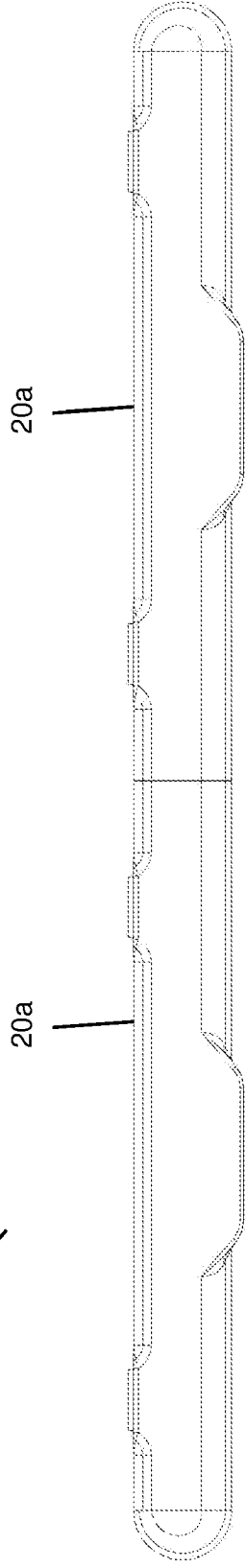

Figure 11

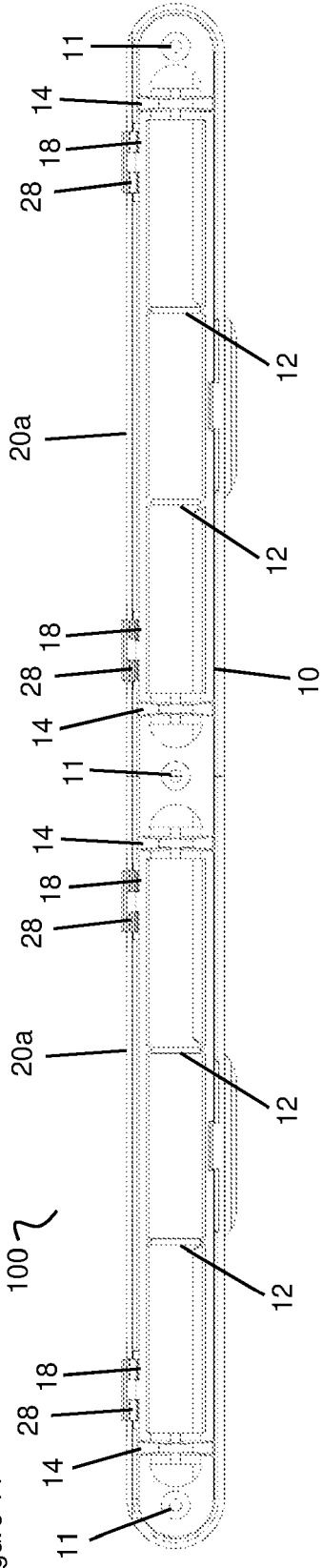

Figure 12

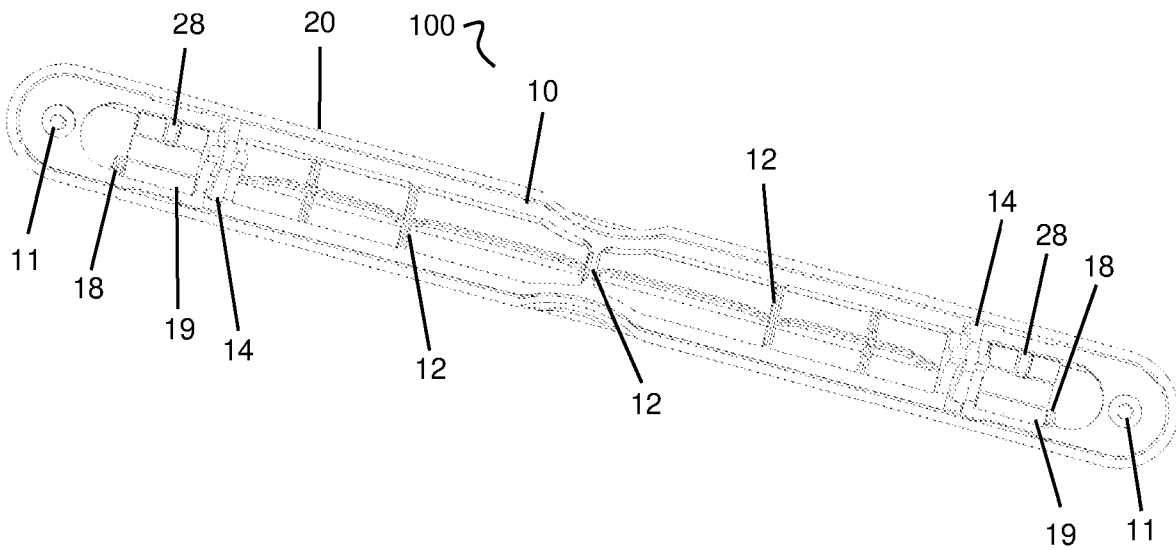

Figure 13

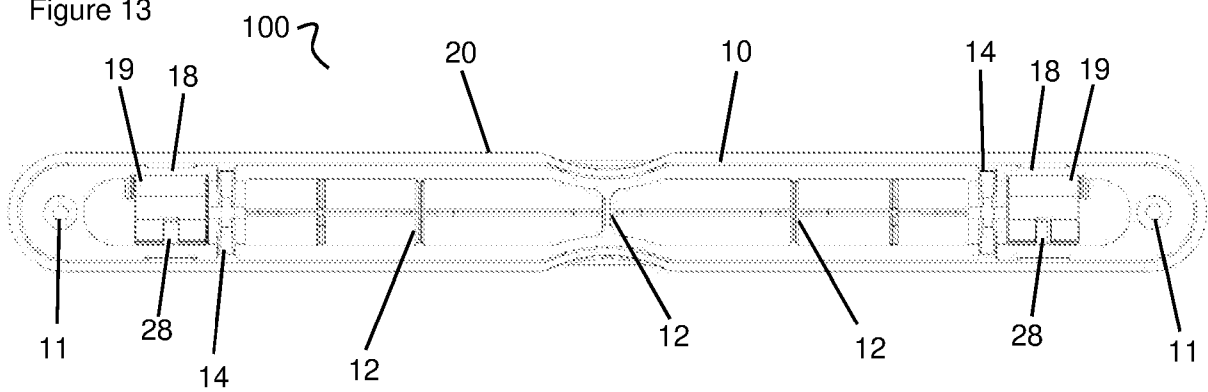

Figure 14

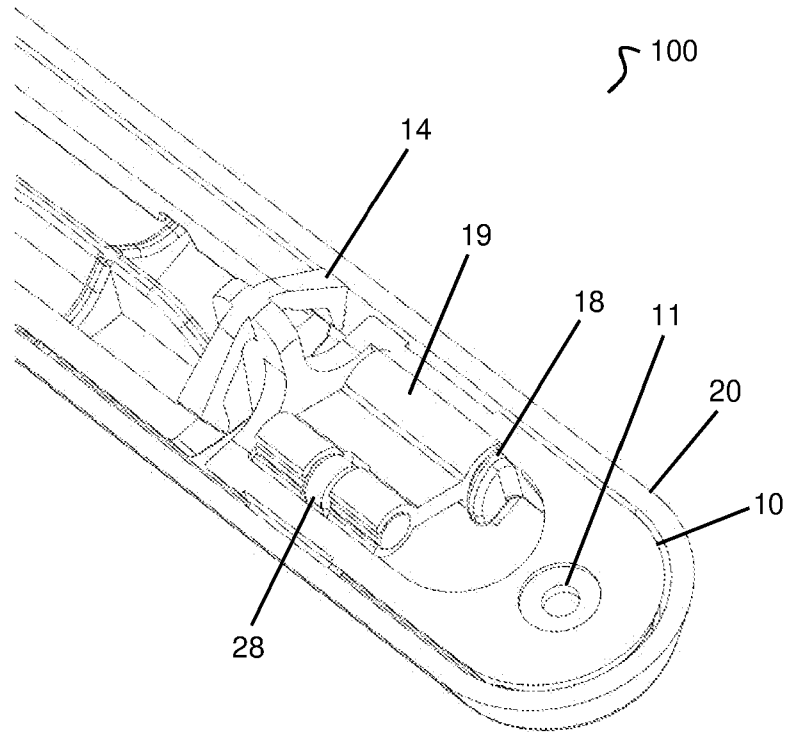

Figure 15

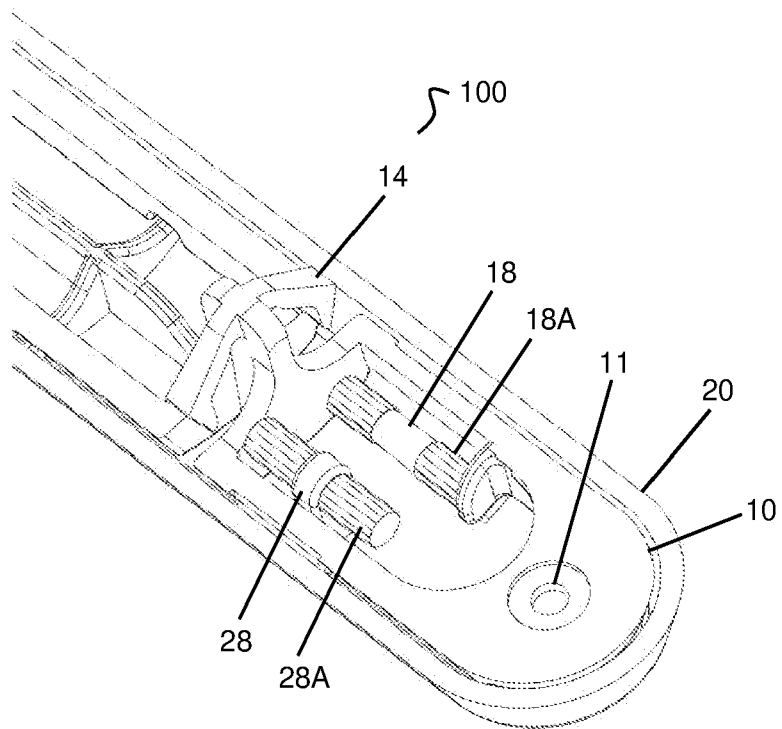

Figure 16

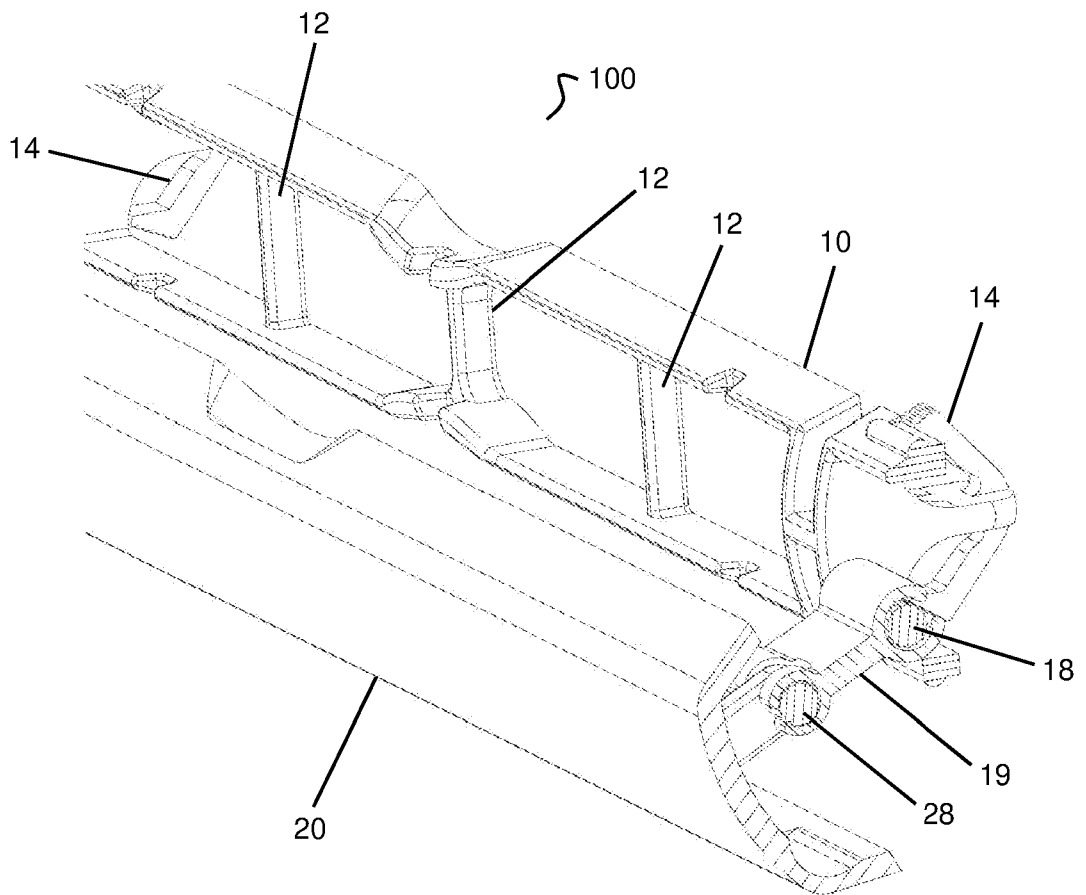
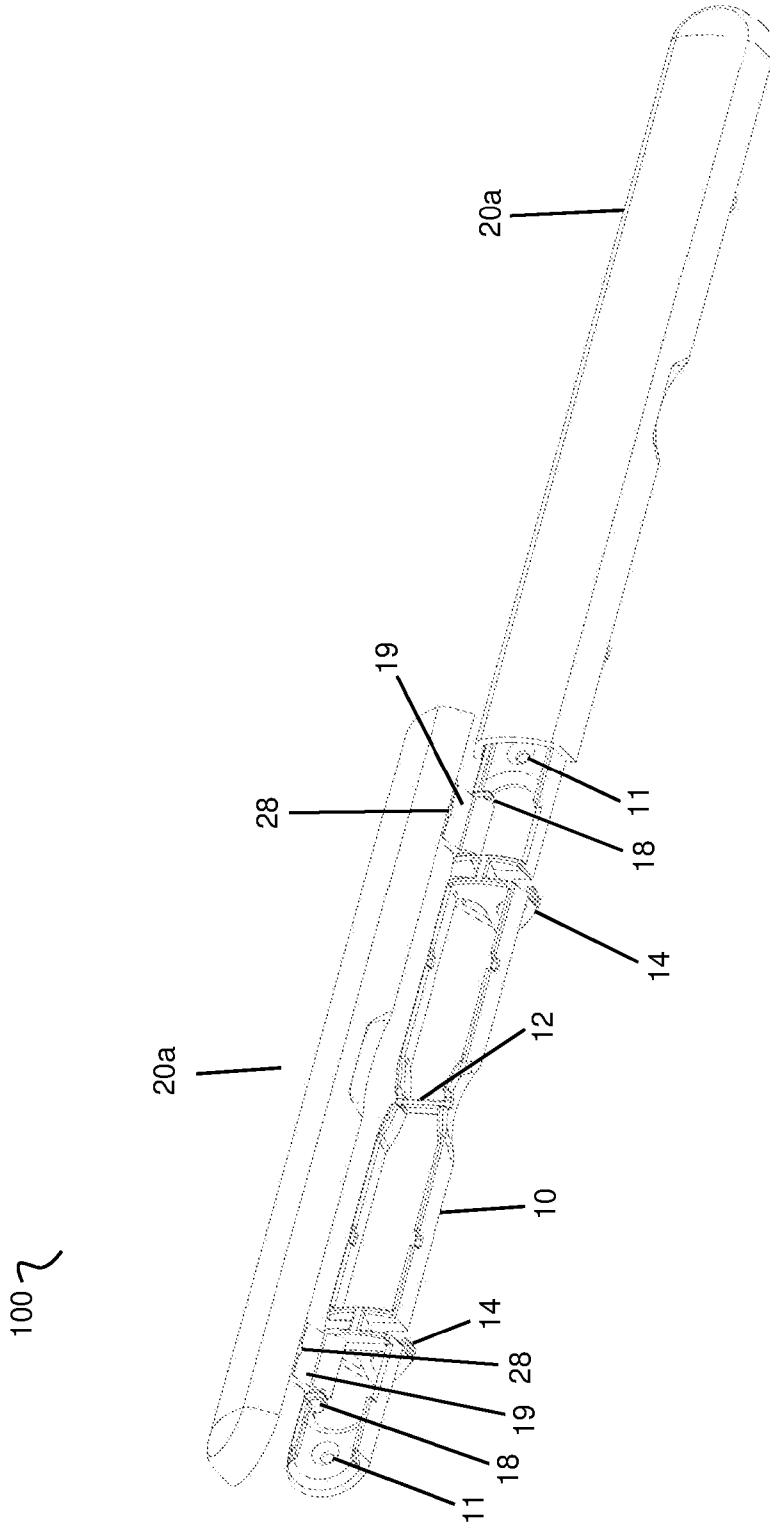

Figure 17



100 2

Figure 18

100 ~

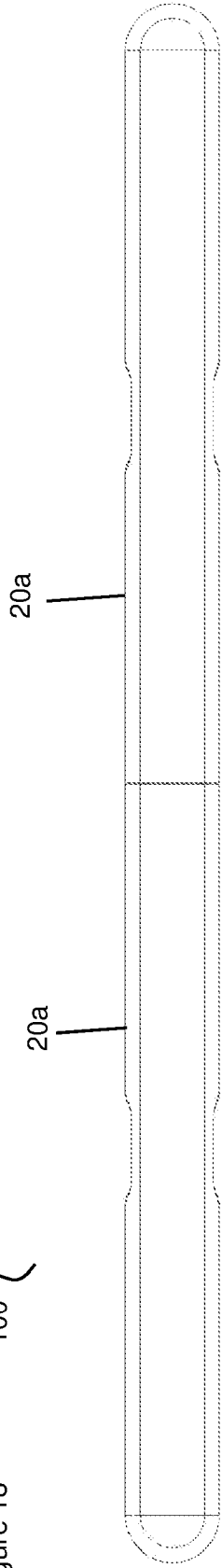
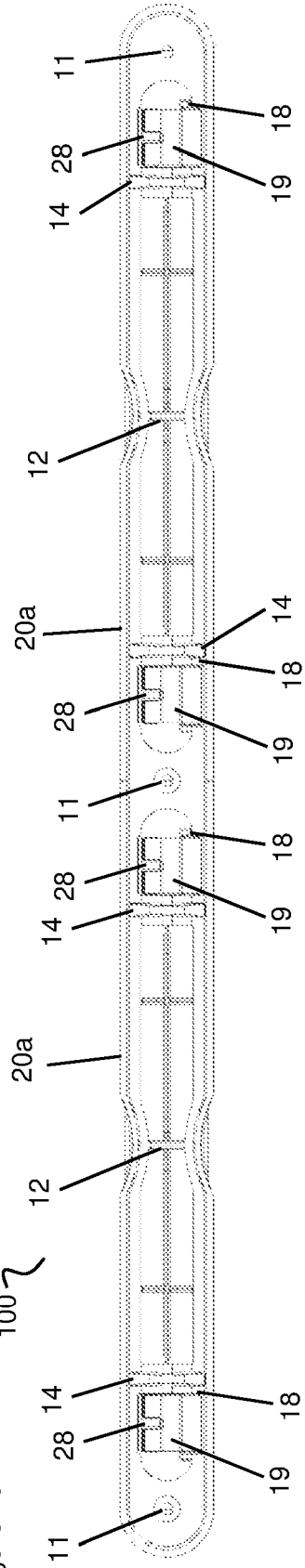

Figure 19

100 ~



VENT FOR A WINDOW FRAME

Background

5 The present disclosure relates to a vent for a window frame. These are typically referred to as trickle vents, trickle ventilators, background vents or background ventilators.

10 With improvements in home insulation over recent years, it has become increasingly difficult for excess moisture in the air to escape. This can result in a build-up of condensation. Further, inhabitants of a building may not be exposed to outdoor air. To combat this, trickle ventilation (also known as background ventilation) in window frames has become increasingly common. Such trickle ventilation provides a small flow of air – a “trickle” – into the building. These trickle vents should still, however, provide protection against cold draughts.

15 Indeed, a number of building regulations require for trickle ventilation in new or replacement window frames. For example, in the United Kingdom this is set out in the Building Regulations (2010) *Approved Document F: Ventilation – Volume 1: Dwellings*. 2021 edition (ISBN 978-1-914124-76-1) – hereinafter referred to as “the Regulations”. The purpose of this is to protect the health of occupants of the building by providing adequate
20 ventilation. Without adequate ventilation, mould and internal air pollution might become hazardous to health.

25 The Regulations require for new buildings to have background ventilators on all rooms with external walls (see 1.52 of the Regulations). These background ventilators must have a minimum equivalent area of at least 8,000 mm² for a habitable room or kitchen (rising to at least 10,000 mm² for a single-storey dwelling) and 4,000 mm² for a bathroom (see Table 1.7 of the Regulations). Similar requirements also apply when modifying existing buildings such as by replacing windows (see 3.14 and 3.15 of the Regulations) or adding rooms (see 3.17 of the Regulations).

30 While the Regulations specifically apply to the United Kingdom, such requirements for trickle ventilation are becoming increasingly common around the world.

35 With these increasingly-large trickle ventilators required, there are a number of issues presented. Firstly, even with a closed position the design of the trickle ventilators often

does not allow for effective sealing. Thus, even in the closed position a flow of air may not be effectively prevented. The counter to this is the desire to reduce the overall profile of the device so as to avoid interfering with any window coverings as well as avoiding unsightly protuberances.

5

An earlier slot ventilator design is disclosed in EP 2 634 497 A2, the entire contents of which is incorporated by reference. The slot ventilator comprises a frame defining a slot with a longitudinal axis, at least one cover member, and a linkage connecting the cover member to the frame for movement between a first position in which the cover closes the slot and a second position in which the slot is open. The linkage is configured to allow the cover member to translate in a direction perpendicular to the longitudinal axis away from the frame, and to rotate about an axis parallel to the longitudinal axis, but to prohibit movement of the cover member in a direction parallel to the longitudinal axis. In the second position the cover member is positioned adjacent to and spaced from the frame and clear of the slot. This allows an unobstructed airflow to run through the slot ventilator.

10
15

However, in the closed position the cover member simply abuts the frame which does not necessarily achieve a strong seal against airflow. This also results in an increased protrusion of the device.

20

There is therefore a need for an improved vent for a window frame.

GB 2 275 104 A discloses a slot ventilator which has first and second base portions which in use are secured to a fascia, for example a window frame, one at each end of an elongate opening therein.

25

GB 2 335 975 A discloses a vent device for mounting over an air passageway in a window or a door frame.

30

Summary

A vent for a window frame is provided according to claim 1 or clause 1. This vent frame effectively blocks airflow while having a low profile. In other words, the vent frame fully surrounds the slot and/or defines a complete perimeter of the slot. That is, the slot is formed in the vent frame. By defines it is meant that the vent frame sets the boundaries of the slot. Particularly the frame body may define the slot.

35

The cover attachment may comprise a hinge for receiving the frame attachment. This is an effective way to attach the cover to the frame.

- 5 The hinge may extend through the cover member. This can further allow for reduction in the profile of the device.

10 The vent may further comprise a linkage connecting the frame attachment and the cover attachment, the linkage configured to allow the cover member to translate in a direction perpendicular to the longitudinal axis away from the vent frame, and to rotate about an axis parallel to the longitudinal axis. Such a linkage can more effectively move the cover member out of the way of the slot and hence allow more air flow through the vent.

15 The cover attachment and/or the frame attachment may comprise a textured surface for retaining the cover member in a partially-open position between the closed position and the open position. This allows the vent to be placed in a partially-open position to allow further control of airflow through the vent.

20 The cover member may be a generally hemicapsule shell, defining a stadium perimeter surrounding the frame body in the closed position. This is an effective shape for the vent.

The cover member may be a generally cuboid shell, defining a rectangular perimeter surrounding the frame body in the closed position. This is an effective shape for the vent.

25 The vent may further comprise a seal surrounding the slot, the cover member arranged to contact the seal in the closed position to seal the vent. A seal can help to prevent airflow through the vent when it is closed and thereby improve insulation.

30 The vent frame may comprise one or more reinforcements extending across the frame body in a direction perpendicular to the longitudinal axis. These reinforcements allow for the outer size of the vent to be reduced.

The vent frame may comprise one or more window fixing(s) for attaching the vent to a window frame. These allow for effective fitting of the vent to the window frame.

Each window fixing may comprise an integral protrusion with one or more resiliently deformable arm(s) extending from the protrusion. The vent is formed in one piece with these integral protrusions, making the installation simpler.

- 5 The frame body may further comprise a fastening section for receiving a fastener to attach the vent to a window frame. This can further strengthen the attachment of the vent to the window frame.

10 The cover member may be formed of a plurality of cover portions. Having a plurality of cover portions can simplify the manufacture of the vent and allow larger vent sizes to be produced.

15 Each cover portion may be independently moveable between: a closed position in which each cover portion completely envelops a corresponding portion of the frame body to block airflow through a corresponding portion of the vent; and an open position in which each cover portion is spaced from a corresponding portion of the vent frame to allow airflow through the corresponding portion of vent, wherein with each cover portion in the closed position the plurality of cover portions collectively completely envelop the frame body to block airflow through the vent. Having each cover portion independently moveable means
20 that the airflow through the vent can be more particularly controlled.

The cover member may be a single continuous piece. A single cover piece can simplify the overall design of the vent and allow easy closing of the vent.

- 25 A window assembly is provided according to claim 16 or clause 16.

A method of fitting a vent to a window frame is provided according to claim 17 or clause 17.

Brief Description of the Drawings

- 30 The present specification makes reference to the accompanying drawings, by way of example only, in which:

Figure 1 shows a front perspective view of a first size vent for a window frame according to a first example in an open position;

Figure 2 shows a rear perspective view of the vent of Figure 1 in an open position;

- 35 Figure 3 shows a front perspective view of the vent of Figure 1 in a closed position;

Figure 4 shows a rear perspective view of the vent of Figure 1 in a closed position;

Figure 5 shows a front view of the vent of Figure 1 in a closed position;

Figure 6 shows a rear view of the vent of Figure 1 in a closed position;

Figures 7 and 8 show rear detail views of the vent of Figure 1 in a closed position;

5 Figure 9 shows a front perspective view of a second size vent for a window frame according to the first example in a partially open position;

Figure 10 shows a front perspective view of the vent of Figure 9 in a closed position;

Figure 11 shows a rear perspective view of the vent of Figure 9 in a closed position;

10 Figure 12 shows a rear perspective view of a first size vent for a window frame according to a second example in a closed position;

Figure 13 shows a rear view of the vent of Figure 12 in a closed position;

Figure 14 shows a rear detail view of the vent of Figure 12 in a closed position;

15 Figure 15 shows a rear detail view of the vent of Figure 12 in a closed position with a linkage omitted;

Figure 16 shows a front perspective detail view in partial cross-section of the vent of Figure 12 in an open position;

Figure 17 shows a front perspective view of a second size vent for a window frame according to the second example in a partially open position;

20 Figure 18 shows a front perspective view of the vent of Figure 17 in a closed position; and

Figure 19 shows a rear perspective view of the vent of Figure 17 in a closed position.

25 **Detailed Description**

A first example of a vent 100 for a window frame is shown in Figures 1 to 8 in a first, smaller, size and in Figures 9 to 11 in a second, larger, size. A second example of a vent 100 for a window frame is shown in Figures 12 to 16 in a first, smaller, size and in Figures 17 to 19 in a second, larger, size. Each vent 100 may be defined as a trickle vent. For the
30 avoidance of doubt, any feature disclosed in relation to one embodiment and/or one size may equally apply to the other embodiment unless expressly stated otherwise.

Figures 1 and 2 show the first example vent 100 in an open position. Figure 1 shows the vent 100 from the front side – the side of the vent 100 which is faces, in use, away from a

window frame, towards the interior of a building. Figure 2 shows the vent 100 from a rear side – the side of the vent 100 which faces and contacts, in use, the window frame.

5 The vent 100 comprises a vent frame which defines a slot with a longitudinal axis L. The vent frame defines a full perimeter of the slot. That is, the vent frame fully surrounds the slot.

10 The slot may generally be defined as a gap in the vent 100 through which air can flow. The longitudinal axis L extends along the longest dimension of the slot. In other words, the vent frame fully surrounds the slot, and/or defines a complete perimeter of the slot. This may be referred to as the vent frame comprising the slot. The slot may be interrupted such as via one or more reinforcements 12 and/or guide vanes. These reinforcements 12 or guide vanes may act to direct a flow of air through the vent 100. These reinforcements 12 may extend across the frame body 10 in a direction transverse or perpendicular to the
15 longitudinal axis L.

The vent frame comprises a frame body 10 and a cover attachment 18. It may be this frame body 10 of the vent frame which defines the slot. The vent frame, in use, generally surrounds a through bore in a window frame. The vent frame may be continuous and
20 define a complete perimeter of the slot. The frame body 10 may be generally continuous, defining an outer perimeter on a surface of the vent 100 which, in use, contacts the window frame. The continuous frame body 10 may be a unitary/integral piece – i.e. formed as one part. Alternatively, the continuous frame body 10 may be formed of multiple pieces attached together. As shown in Figure 2, there may be slight breaks in this continuous
25 outer perimeter such as in the area of one or more window fixing(s) 14. These do not affect the general perimeter shape of the frame body 10.

For example, the frame body 10 may define a generally stadium perimeter as shown in the Figures. A stadium perimeter is defined as two-dimensional geometric shape constructed
30 of a rectangle with semicircles at a pair of opposite sides. In alternative examples, the frame body 10 may define a generally rectangular perimeter. In any event, the perimeter may, in use, substantially surround the through bore formed in the window frame. The slot defined by the vent frame is then arranged around this through bore in the window frame.

The cover attachment 18 may take any suitable form, and the first and second example vent 100 show alternative forms for the cover attachment 18. In the first example vent 100, the cover attachment 18 is generally in the form of a hinge which receives a frame attachment 28 of a cover member 20 (discussed in detail below). That is, the cover attachment 18 is a slot which receives the frame attachment 28. The cover attachment 18 may be resiliently deformable, so as to enable a snap fit between the cover attachment 18 and the frame attachment 28.

The vent frame is attachable to a window frame to surround the through bore in the window frame. For example, the vent frame may comprise one or more window fixings 14 for attaching the vent 100 to the window frame. These window fixings 14 may be, for example, in the form of an integral protrusion extending from the frame body 10. By integral, it is meant that the window fixing 14 and frame body 10 are formed as a single piece. The window fixing 14 may comprise one or more resiliently deformable arms which extend from this protrusion.

In use, the integral protrusion may be inserted into the through bore in the window frame. A total width of the integral protrusion including the resiliently deformable arms may exceed the corresponding dimension of the through bore. Thus, during insertion the resiliently deformable arms may be deformed to reduce the total width. Thus, the resiliently deformable arms may retain the vent 100 to the window frame.

The vent 100 may, additionally or alternatively, further comprise a fastening section 11 for receiving a fastener to attach the vent 100 to a window frame. For example, as shown in the Figures the fastening section 11 may be a bore through the vent body 10. This bore can receive a fastener such as a screw which is then screwed into the window frame. This fastening section 11 can be used in addition to the window fixings 14, or alternatively to the window fixings 14.

The vent 100 further comprises a cover member 20. The cover member 20 is pivotally attached to the vent frame. The cover member 20 comprises a frame attachment 28 which is pivotally attached to the cover attachment 18 of the vent frame. This may be a direct pivotal attachment such as shown in the first example vent 100. Alternatively, there may be an intervening linkage 19 such as shown in the second example vent 100 and described in detail below. The cover member 20 may be a single continuous piece as shown in Figures

1 to 8. Alternatively, the cover member may be formed of a plurality of cover portions 20a as shown in Figures 9 to 11 and discussed in relation thereto below.

5 The cover member 20 is moveable, via this pivotal attachment, between a closed position and an open position. For the first example vent 100, the open position is shown in Figures 1 and 2 and the closed position is shown in Figures 3 to 8.

The cover member 20 simply moves between the open position and closed position by pivoting through the cover attachment 18 and frame attachment 28.

10

In the open position, the cover member 20 is spaced from the vent frame to allow airflow through the vent 100.

15 In the closed position, the cover member 20 completely envelops the frame body 10 thereby block airflow through the vent 100. That is, the cover member 20 entirely receives the frame body 10. As can be seen in at least Figures 4 and 6, this means that for each part of the frame body 10 there is a corresponding part of the cover member 20 which is spaced outwardly of this in a plane of the window frame. In the first example, the frame attachment 28 of the cover member 20 forms a part of this envelopment as it covers the section of the frame body 10 from which the cover attachment 18 extends. The cover attachment 18 can extend through the cover member 20 as in the first example vent 100.

25 The cover member 20 may be a generally hemicapsule shell. The hemicapsule shell defines a stadium perimeter surrounding the frame body 10 in the closed position. That is, the cover member 20 may be half of a capsule (in the same way as a hemisphere is half of a sphere). A capsule, or stadium of revolution, is a three-dimensional geometric shape consisting of a cylinder with hemispherical ends. Another name for this shape is spherocylinder. As above, a stadium is a two-dimensional geometric shape constructed of a rectangle with semicircles at a pair of opposite sides. Revolving this stadium about a line of symmetry bisecting the semicircles forms a capsule. The cover member 20 may not be exactly half of a capsule shell, but, instead, of this general shape. For the avoidance of doubt, the halving of the capsule is along its longest axis – that is, from pole to pole of each end hemisphere.

30

In alternative examples, the cover member 20 may be a generally cuboid shell, defining a rectangular perimeter that surrounds the frame body 10 in the closed position.

5 The cover attachment 18 and/or the frame attachment 28 may comprises a textured surface. This textured surface may be for retaining the cover member 20 in a partially-open position between the closed position and the open position. That is, the textured surface may result in frictional contact to hold the cover member 20 in the partially-open position. For example, there may be one or more of grooves, ridges, and/or knurling on the cover attachment 18 and/or the frame attachment 28.

10

The vent 100 may further comprise a seal surrounding the slot. For example, the seal may be provided generally around the frame body 10 or the cover member 20. The seal may be arranged such that the cover member 20 contacts the seal in the closed position in order to seal the vent 100 against airflow through the slot.

15

For situations where a larger vent 100 is desired, such as to increase airflow, the second size vent 100 of Figures 9 to 11 may be provided. This vent 100 is generally in accordance with the first example vent described above in relation to Figures 1 to 8. The key difference between the two sizes is that the frame body 10 may be elongated in the direction of (along) the longitudinal axis L. A width and/or a depth of the frame body 10 in a direction perpendicular to the longitudinal axis L may be substantially the same for the first size and the second size of the vent 100.

20

The cover member 20 of the larger vent 100 may be formed of a plurality of cover portions 20a. Each cover portion 20a may be attached to the vent frame as discussed above in relation to the smaller vent 100. Each cover portion 20a may be independently moveable between its own open position and closed position. In the closed position, each cover portion 20a envelops a corresponding portion of the frame body. A corresponding portion means the parts of the vent 100 which are aligned with the cover portion 20a in the direction of the longitudinal axis L.

30

Collectively, the cover portions 20a completely envelop the frame body 10 to thereby block airflow through the vent 100. That is, the cover member 20 as defined by the plurality of cover portions 20a entirely receives the frame body 10. There may be a slight gap between the two cover portions 20a in the direction of the longitudinal axis L, but this is negligible for

35

the purposes of the present invention. The frame body 10 may have a solid portion that aligns with this gap to prevent airflow therethrough.

5 One or more cover portions 20a may be connectable to one another so as to move in conjunction. For example, via a latch or other component. In certain vents 100, one or more cover portions 20a may be permanently affixed to one another so as to move together between the open and closed positions.

10 In this sense, a larger vent 100 may be provided according to the first example. Operation of this vent 100 is as described above in relation to the smaller vent of the first example.

15 Figures 12 to 19 show a second example vent 100 in two sizes. The first size vent is smaller and is shown in Figures 12 to 16, and the second size vent is larger and is shown in Figures 17 to 19. This second example vent 100 has an alternative arrangement for the pivotal connection between the cover member 20 and the vent frame. Unless otherwise specified, all features of this second example vent 100 are in accordance with the description of the first example vent 100.

20 The second example vent 100 further comprises a linkage 19. The linkage 19 pivotally connects the frame attachment 28 and the cover attachment 18. The frame attachment 28 may be a pivot point. The cover attachment 18 may be a pivot point. The linkage 19 is configured to allow the cover member 20 to translate in a direction perpendicular to the longitudinal axis L away from the vent frame, and to rotate about an axis parallel to the longitudinal axis L. This linkage 19 is generally similar to that which is disclosed in EP 2
25 634 497 A2, the entire contents of which is incorporated by reference.

This arrangement allows for the cover member 20 to be further spaced away from the slot and thereby avoiding the disruption of any airflow through the vent 100.

30 To move from the closed position of Figures 12 to 15 to the open position of Figure 16, a user pulls the cover member 20 away from the vent frame. Movement between the closed position and the fully open position may be largely achieved through rotation about the cover attachment 18. However, some rotation about frame attachment 28 may also occur, allowing the cover member 20 to translate in a direction perpendicular to the longitudinal
35 axis L. As the rotation axis of the cover attachment 18 is parallel with the longitudinal axis

L, during movement between the closed position and they open position, the cover member 20 simply rotates about the cover attachment 18 in a first direction away from the vent frame and there is no movement of the cover member 20 in a direction parallel to the longitudinal axis L of the vent 100. As no such parallel movement occurs in the cover member 20, less clearance space is required on the window frame.

To move from the open position of Figure 16 to the closed position of Figures 12 to 15, the user simply applies upward pressure to the cover member 20 to cause it to rotate in a direction back towards the vent frame.

10

Figure 15 shows how one or both of the cover attachment 18 and/or the frame attachment 28 may comprise a textured surface for retaining the cover member 20 in a partially-open position between the closed position and the open position. For example, as shown in Figure 15 there may be a series of ridges and grooves provided which produce friction to hold the cover member 20 in the partially-open position.

15

While Figure 15 shows the cover attachment 18 spaced from the outer frame body 10, this is not necessarily the case. In certain examples the cover attachment 18 may effectively form a section of the frame body 10 in this region. That is, the piece of frame body 10 shown in Figure 15 in the region of the cover attachment 18 may be removed. The cover attachment 18 may then act as a structural component of the frame body 10. This can allow the vent 100 to open to a greater extent as the linkage 19 may be elongated with the cover attachment 18 moved further from the frame attachment 28.

20

For situations where a larger vent 100 is desired, such as to increase airflow, the second size vent 100 of Figures 17 to 19 may be provided. This vent 100 is generally in accordance with the second example vent described above in relation to Figures 12 to 16. The key difference between the two sizes is that the frame body 10 may be elongated in the direction of (along) the longitudinal axis L. A width and/or a depth of the frame body 10 in a direction perpendicular to the longitudinal axis L may be substantially the same for the first size and the second size of the vent 100.

25

30

The cover member 20 of the larger vent 100 may be formed of a plurality of cover portions 20a. Each cover portion 20a may be attached to the vent frame as discussed above in relation to the smaller vent 100. Each cover portion 20a may be independently moveable

35

between its own open position and closed position. In the closed position, each cover portion 20a envelops a corresponding portion of the frame body. A corresponding portion means the parts of the vent 100 which are aligned with the cover portion 20a in the direction of the longitudinal axis L.

5

Collectively, the cover portions 20a completely envelop the frame body 10 to thereby block airflow through the vent 100. That is, the cover member 20 as defined by the plurality of cover portions 20a entirely receives the frame body 10. There may be a slight gap between the two cover portions 20a in the direction of the longitudinal axis L, but this is negligible for the purposes of the present invention. The frame body 10 may have a solid portion that aligns with this gap to prevent airflow therethrough.

10

In this sense, a larger vent 100 may be provided according to the second example. Operation of this vent 100 is as described above in relation to the smaller vent of the second example.

15

A window assembly is also provided. Generally, a window assembly relates to the combination of a window frame and a vent 100 as described in the present invention. The window frame comprises a through bore. That is, a through bore from an interior of the window frame to an exterior. In use, this would be a bore from the interior of a building in which the window frame is mounted to the outside. The vent 100 may be of the first example or second example, or any other suitable vent 100. The vent 100 is attached to the window frame such that the vent frame, particularly the frame body 10, substantially surrounds the through bore.

20

A method of fitting a vent 100 to a window frame is also provided. The vent 100 may be of the first example or second example, or any other suitable vent 100. The window frame comprises a through bore. If the window frame does not comprise a through bore, one can be formed therein such as by drilling and/or milling. The method then comprises the step of providing a vent 100 as described herein. Then, the vent 100 is attached to the window frame such that the vent frame, particularly the frame body 10, substantially surrounds the through bore.

30

This method may be carried out in situ with an existing window to retrofit a vent 100. Alternatively, the method may be carried out as the window frame is manufactured.

35

CLAUSES

1. A vent for a window frame comprising:
a vent frame defining a slot with a longitudinal axis, the vent frame comprising a
frame body and a cover attachment;
5 a cover member comprising a frame attachment pivotally attached to the cover
attachment, the cover member moveable between:
a closed position in which the cover member completely envelops the frame
body to block airflow through the vent; and
an open position in which the cover member is spaced from the vent frame
10 to allow airflow through the vent.
2. The vent of any preceding clause, wherein the cover attachment comprises a hinge
for receiving the frame attachment.
- 15 3. The vent of clause 2, wherein the hinge extends through the cover member.
4. The vent of clause 1, further comprising a linkage connecting the frame attachment
and the cover attachment, the linkage configured to allow the cover member to translate in
a direction perpendicular to the longitudinal axis away from the vent frame, and to rotate
20 about an axis parallel to the longitudinal axis.
5. The vent of any preceding clause, wherein the cover attachment and/or the frame
attachment comprises a textured surface for retaining the cover member in a partially-open
position between the closed position and the open position.
25
6. The vent of any preceding clause, wherein the cover member is a generally
hemispherical shell, defining a stadium perimeter surrounding the frame body in the closed
position.
- 30 7. The vent of any of clauses 1 to 5, wherein the cover member is a generally cuboid
shell, defining a rectangular perimeter surrounding the frame body in the closed position.
8. The vent of any preceding clause, further comprising a seal surrounding the slot,
the cover member arranged to contact the seal in the closed position to seal the vent.

9. The vent of any preceding clause, wherein the vent frame comprises one or more reinforcements extending across the frame body in a direction perpendicular to the longitudinal axis.

5 10. The vent of any preceding clause, wherein the vent frame comprises one or more window fixing(s) for attaching the vent to a window frame.

11. The vent of clause 10, wherein each window fixing comprises an integral protrusion with one or more resiliently deformable arm(s) extending from the protrusion.

10

12. The vent of any preceding clause, wherein the frame body further comprises a fastening section for receiving a fastener to attach the vent to a window frame.

13. The vent of any preceding clause, wherein the cover member is formed of a plurality of cover portions.

15

14. The vent of clause 13, wherein each cover portion is independently moveable between:

20 a closed position in which each cover portion completely envelops a corresponding portion of the frame body to block airflow through a corresponding portion of the vent; and

an open position in which each cover portion is spaced from a corresponding portion of the vent frame to allow airflow through the corresponding portion of vent, wherein with each cover portion in the closed position the plurality of cover portions collectively completely envelop the frame body to block airflow through the vent.

25

15. The vent of any of clauses 1 to 12, wherein the cover member is a single continuous piece.

16. A window assembly comprising:

30

a window frame comprising a through bore; and

the vent of any preceding clause attached to the window frame such that the vent frame substantially surrounds the through bore.

17. A method of fitting a vent to a window frame, the window frame comprising a through bore, the method comprising the steps of:

35

providing a vent according to any of clauses 1 to 15; and
attaching the vent to the window frame such that the vent frame substantially
surrounds the through bore.

CLAIMS:

1. A vent for a window frame comprising:
a vent frame defining a full perimeter of a slot with a longitudinal axis, the vent
frame comprising a frame body and a cover attachment;
5 a cover member comprising a frame attachment pivotally attached to the cover
attachment, the cover member moveable between:
a closed position in which the cover member completely envelops the frame
body to block airflow through the vent; and
an open position in which the cover member is spaced from the vent frame
10 to allow airflow through the vent.
2. The vent of any preceding claim, wherein the cover attachment comprises a hinge
for receiving the frame attachment.
- 15 3. The vent of claim 2, wherein the hinge extends through the cover member.
4. The vent of claim 1, further comprising a linkage connecting the frame attachment
and the cover attachment, the linkage configured to allow the cover member to translate in
a direction perpendicular to the longitudinal axis away from the vent frame, and to rotate
20 about an axis parallel to the longitudinal axis.
5. The vent of any preceding claim, wherein the cover attachment and/or the frame
attachment comprises a textured surface for retaining the cover member in a partially-open
position between the closed position and the open position.
25
6. The vent of any preceding claim, wherein the cover member is a generally
hemispherical shell, defining a stadium perimeter surrounding the frame body in the closed
position.
- 30 7. The vent of any of claims 1 to 5, wherein the cover member is a generally cuboid
shell, defining a rectangular perimeter surrounding the frame body in the closed position.
8. The vent of any preceding claim, further comprising a seal surrounding the slot, the
cover member arranged to contact the seal in the closed position to seal the vent.

9. The vent of any preceding claim, wherein the vent frame comprises one or more reinforcements extending across the frame body in a direction perpendicular to the longitudinal axis.

5 10. The vent of any preceding claim, wherein the vent frame comprises one or more window fixing(s) for attaching the vent to a window frame.

11. The vent of claim 10, wherein each window fixing comprises an integral protrusion with one or more resiliently deformable arm(s) extending from the protrusion.

10

12. The vent of any preceding claim, wherein the frame body further comprises a fastening section for receiving a fastener to attach the vent to a window frame.

13. The vent of any preceding claim, wherein the cover member is formed of a plurality
15 of cover portions.

14. The vent of claim 13, wherein each cover portion is independently moveable between:

20 a closed position in which each cover portion completely envelops a corresponding portion of the frame body to block airflow through a corresponding portion of the vent; and

an open position in which each cover portion is spaced from a corresponding portion of the vent frame to allow airflow through the corresponding portion of vent, wherein with each cover portion in the closed position the plurality of cover portions collectively completely envelop the frame body to block airflow through the vent.

25

15. The vent of any of claims 1 to 12, wherein the cover member is a single continuous piece.

16. A window assembly comprising:

30

a window frame comprising a through bore; and

the vent of any preceding claim attached to the window frame such that the vent frame substantially surrounds the through bore.

17. A method of fitting a vent to a window frame, the window frame comprising a
35 through bore, the method comprising the steps of:

providing a vent according to any of claims 1 to 15; and
attaching the vent to the window frame such that the vent frame substantially
surrounds the through bore.



Application No: GB2303715.3

Examiner: Claire Trease

Claims searched: 1-17

Date of search: 7 September 2023

Patents Act 1977: Search Report under Section 17

Documents considered to be relevant:

Category	Relevant to claims	Identity of document and passage or figure of particular relevance
X	1-3, 6-10, 15-17	GB 2299664 A (HARDWARE & SYSTEMS PATENTS LTD) Figs 1-4 show a vent frame with a frame body 10, 11, 12, 16 that defines a full perimeter of a slot, and a cover attachment with a pivotally 9 attached cover member 8 that completely envelops the frame with fixings 15.
A	-	GB 2571072 A (VERO DUCO NV) See figures 2, 4 showing a vent frame 100 defining a full perimeter of a slot 1010 with a longitudinal axis, the vent frame comprising a frame body 200 and a cover attachment 321 with cover member 410.
A	-	GB 2276235 A (HUNTER INTERNATIONAL) See figures 1 and 2 showing a vent frame 2 defining a full perimeter of a slot with a longitudinal axis, the vent frame comprising a frame body 2 and a cover attachment 3 with cover member 1.

Categories:

X	Document indicating lack of novelty or inventive step	A	Document indicating technological background and/or state of the art.
Y	Document indicating lack of inventive step if combined with one or more other documents of same category.	P	Document published on or after the declared priority date but before the filing date of this invention.
&	Member of the same patent family	E	Patent document published on or after, but with priority date earlier than, the filing date of this application.

Field of Search:

Search of GB, EP, WO & US patent documents classified in the following areas of the UKC^X :

Worldwide search of patent documents classified in the following areas of the IPC

E06B; F24F

The following online and other databases have been used in the preparation of this search report

SEARCH PATENT



International Classification:

Subclass	Subgroup	Valid From
E06B	0007/10	01/01/2006
E06B	0007/02	01/01/2006
F24F	0013/18	01/01/2006