



US00D924104S

(12) **United States Design Patent**
Kawakami

(10) **Patent No.:** **US D924,104 S**

(45) **Date of Patent:** **** Jul. 6, 2021**

- (54) **HEADLAMP FOR A BICYCLE**
- (71) Applicant: **Cateye Co., Ltd.**, Osaka (JP)
- (72) Inventor: **Kenta Kawakami**, Osaka (JP)
- (73) Assignee: **Cateye Co., Ltd.**, Osaka (JP)
- (**) Term: **15 Years**

D759,859 S *	6/2016	Ng	D26/28
D760,931 S *	7/2016	Davies	D26/28
D779,690 S *	2/2017	Nagano	D26/28
D779,691 S *	2/2017	Nagano	D26/28
D783,188 S *	4/2017	Espejo	D26/28
D784,575 S *	4/2017	Kawakami	D26/28
D796,386 S *	9/2017	Hu	D12/114

(Continued)

- (21) Appl. No.: **29/664,086**
- (22) Filed: **Sep. 21, 2018**

FOREIGN PATENT DOCUMENTS

JP	1481724	10/2013
JP	1614789	10/2018

(Continued)

(30) **Foreign Application Priority Data**

Mar. 27, 2018 (JP) 2018-006503

(51) **LOC (13) Cl.** **12-11**

(52) **U.S. Cl.**
USPC **D12/114**

(58) **Field of Classification Search**
USPC D12/114; D26/28-36
CPC B62J 6/02; B62J 6/00; B62J 6/001
See application file for complete search history.

(56) **References Cited**

U.S. PATENT DOCUMENTS

D498,550 S *	11/2004	Chen	D26/28
D566,871 S *	4/2008	Kumthampinij	D26/60
D574,986 S *	8/2008	Kumthampinij	D26/60
D597,237 S *	7/2009	Kumthampinij	D26/28
D605,790 S *	12/2009	Hsing-Tsun	D26/28
D706,468 S *	6/2014	Nagano	D26/28
D707,376 S *	6/2014	Cheung	D26/28
D709,225 S *	7/2014	Ueda	D26/28
D715,980 S *	10/2014	Ueda	D26/28
D717,979 S *	11/2014	Ueda	D26/28
D733,342 S *	6/2015	Lee	D26/28
D733,948 S *	7/2015	Liao	D26/28
D751,739 S *	3/2016	Hamasaki	D26/28
D756,027 S *	5/2016	Hamasaki	D26/138
D757,311 S *	5/2016	Nagano	D26/28
D757,968 S *	5/2016	Olson	D26/28

Panasonic ideas for life Nov. 2010, Catalogue of Bicycle Items, p. 1, Dec. 17, 2010.

Primary Examiner — Michelle E. Wilson

Assistant Examiner — Clese Moore, Jr.

(74) *Attorney, Agent, or Firm* — Saul Ewing Arnstein & Lehr LLP; Joseph M. Kuo

(57) **CLAIM**

The ornamental design for a headlamp for a bicycle, as shown.

DESCRIPTION

FIG. 1 is a perspective view of a headlamp for a bicycle showing my new design;

FIG. 2 is a front elevational view thereof;

FIG. 3 is a rear elevational view thereof;

FIG. 4 is a right side view thereof;

FIG. 5 is a left side view thereof;

FIG. 6 is a top plan view thereof; and,

FIG. 7 is a bottom plan view thereof.

The broken lines show portions of the article which form no part of the claimed design.

1 Claim, 5 Drawing Sheets

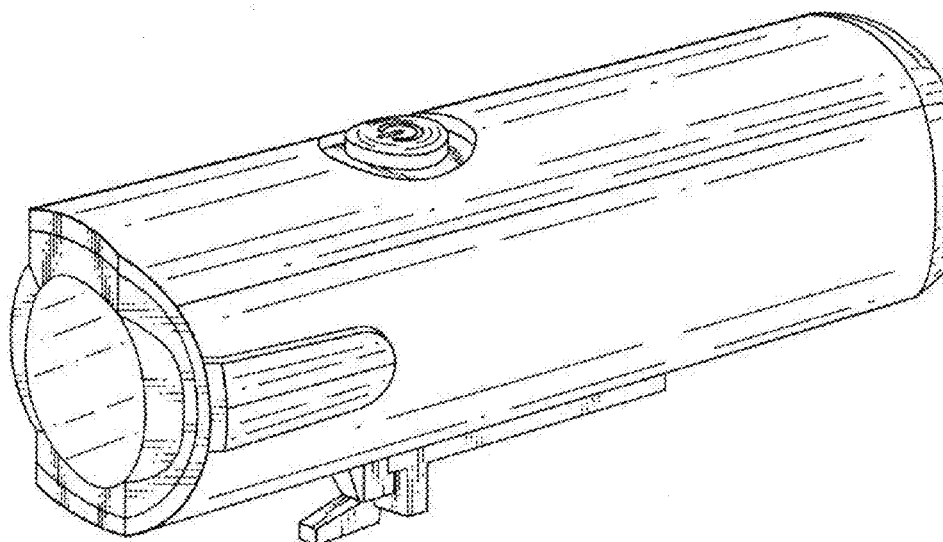

(56)

References Cited

U.S. PATENT DOCUMENTS

D797,006 S * 9/2017 Hu D12/114
D797,007 S * 9/2017 Hu D12/114
2012/0281422 A1* 11/2012 Lee B62J 6/02
362/475

FOREIGN PATENT DOCUMENTS

TW 133351 2/2010
TW 150474 11/2012
TW 133351 11/2013
TW 176526 6/2016
TW 190621 5/2018
TW 190623 5/2018
TW 150474 8/2018

* cited by examiner

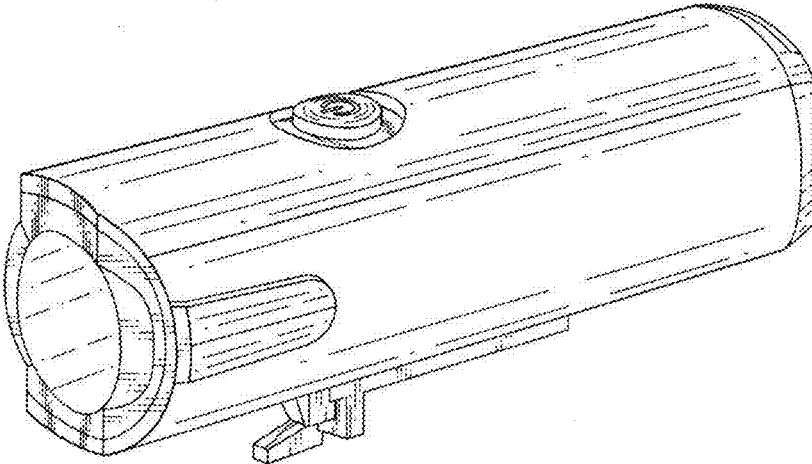

Fig. 1

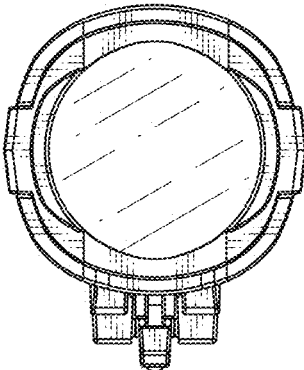

Fig. 2

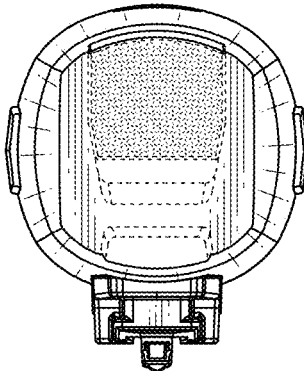

Fig. 3

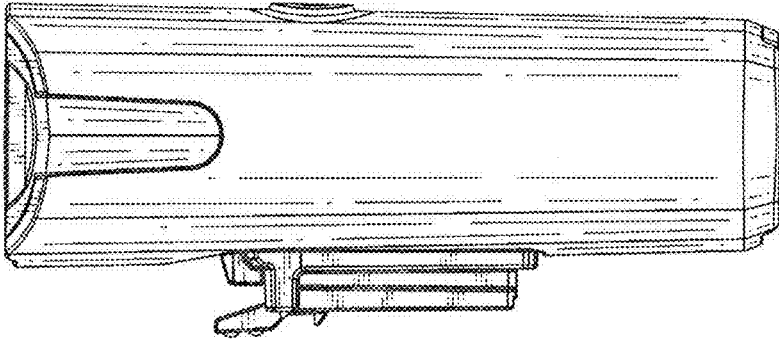

Fig. 4

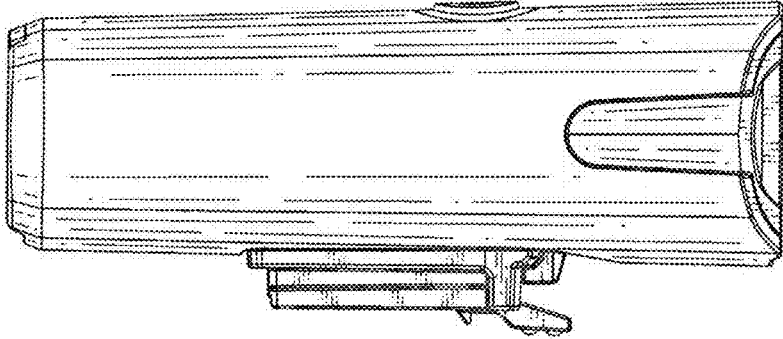

Fig. 5

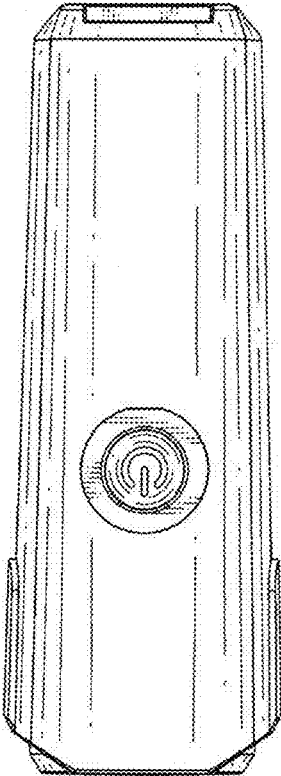

Fig. 6

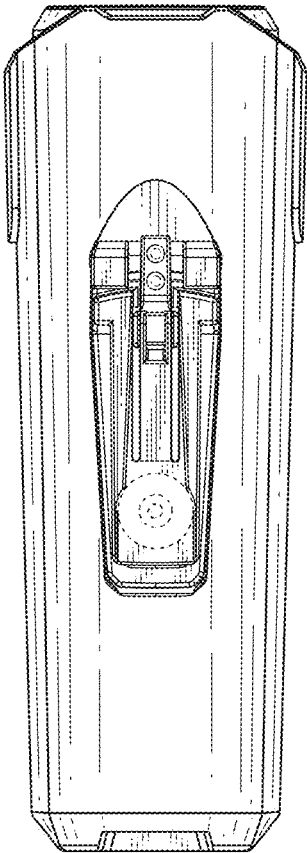

Fig. 7