

[54] **TIMEPIECE MOVEMENT**
 [72] Inventor: **Willy Cleusix**, Biel, Switzerland
 [73] Assignee: **Omega Louis Brandt & Frere S.A.**
 Biel, Canton of Bern, Switzerland
 [22] Filed: **Sept. 22, 1970**
 [21] Appl. No.: **74,278**

[30] **Foreign Application Priority Data**
 Oct. 27, 1969 Switzerland15965/69
 [52] U.S. Cl.....**58/42.5, 58/85.5**
 [51] Int. Cl.....**G04b 19/22, G04b 27/00**
 [58] Field of Search.....**58/23 R, 8, 34, 42.5, 45, 85.5,**
58/116 M

[56] **References Cited**
UNITED STATES PATENTS
 3,233,400 2/1966 Haydon58/34
FOREIGN PATENTS OR APPLICATIONS
 457,295 7/1968 Switzerland58/23 D

Primary Examiner—Richard B. Wilkinson
Assistant Examiner—Edith C. Simmons
Attorney—Imirie & Smiley

[57] **ABSTRACT**

A timepiece movement for driving a plurality of hands, one of which is an hour hand, includes a power train and a pair of identical, coaxially mounted independently rotatable gears operatively connected with the hour hand, one of said gears being driven by said power train and the other of said gears being selectively operated manually, and magnetic means normally coupling said gears for simultaneous rotation but permitting adjustment of said one gear relative to the other to change the indication of said hour hand without affecting any other hand, whereupon following such adjustment said magnetic means effects coincidence of said gears to accurately position the hour hand.

14 Claims, 3 Drawing Figures

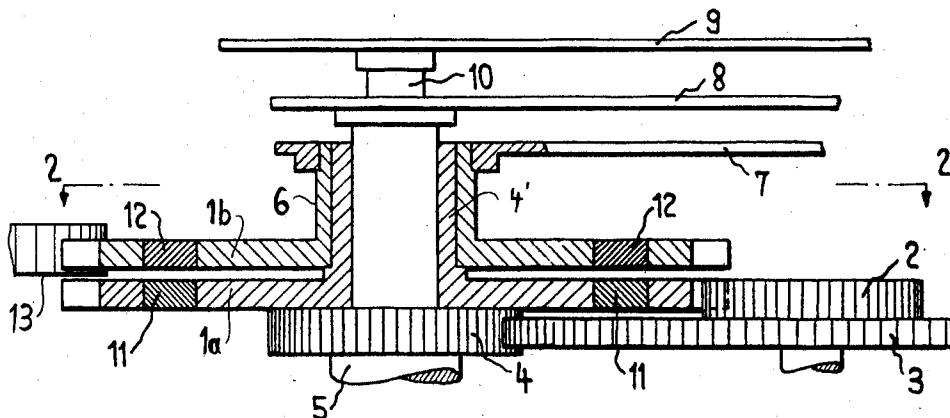

FIG. 1

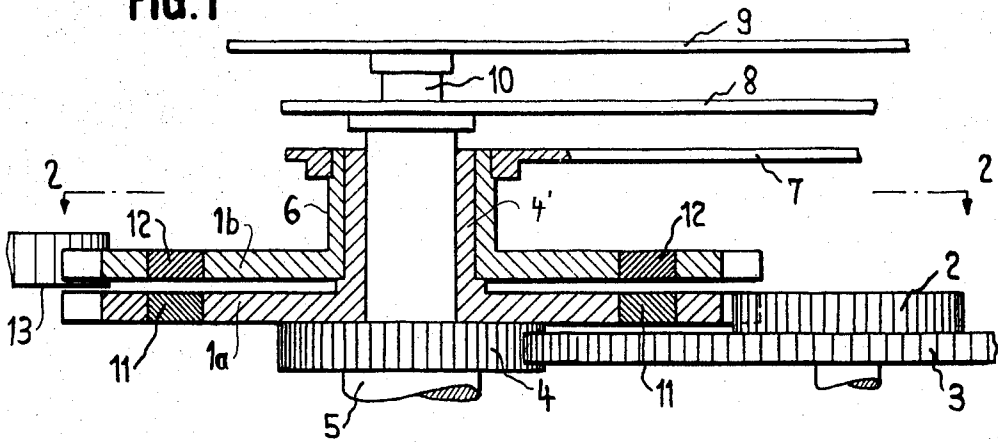

FIG. 2

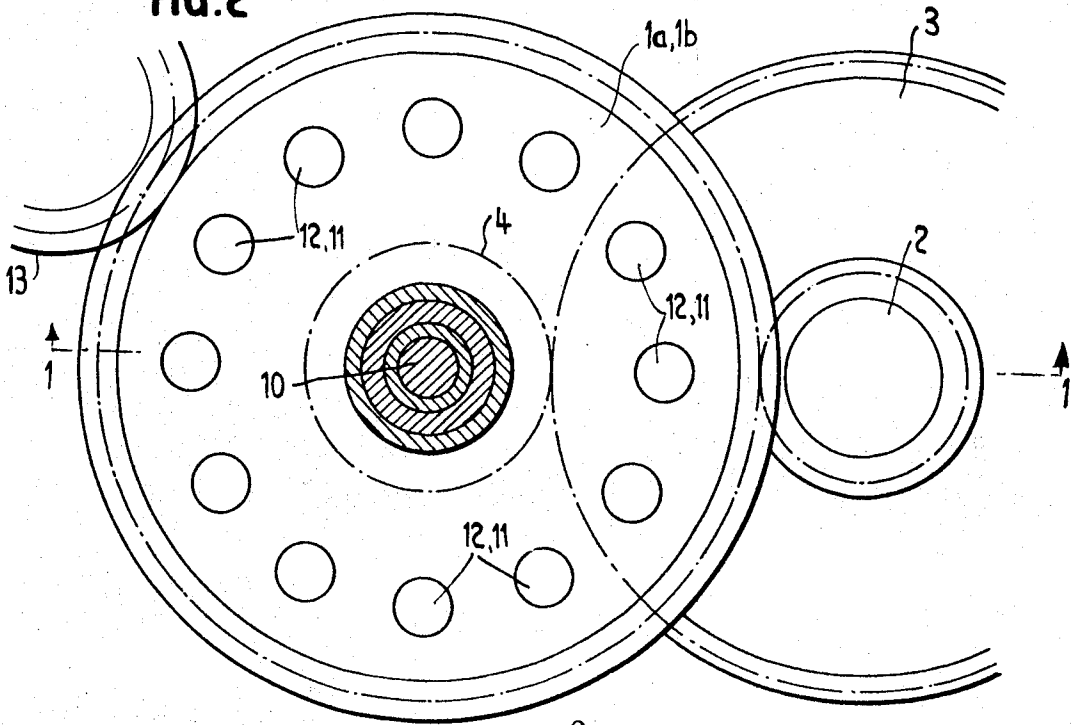
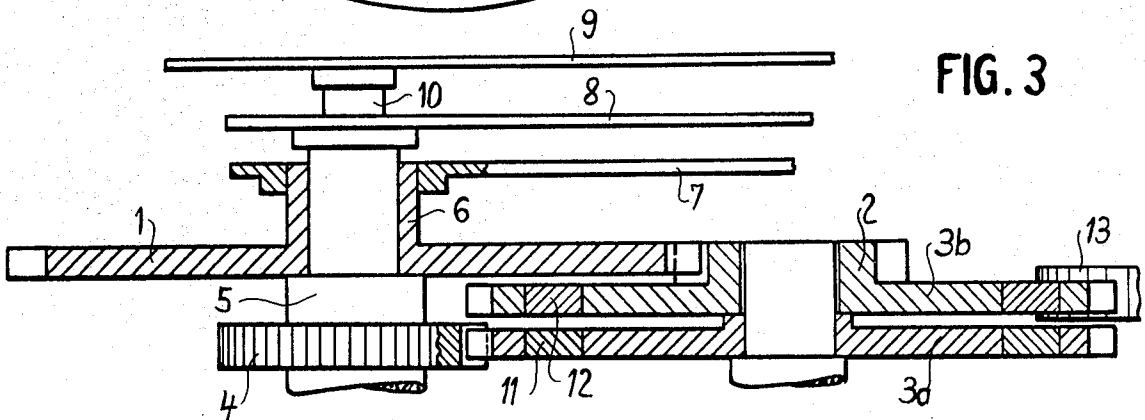

FIG. 3



TIMEPIECE MOVEMENT

BACKGROUND OF THE INVENTION

The present invention relates to a timepiece.

When a user passes from one time-zone to another, for instance on travelling by plane, it is important to change the hour indication by one or more units. If the user actuates the setting mechanism, he loses the indication of the minute and of the second.

SUMMARY OF THE INVENTION

A timepiece movement according to the invention comprises two identical, coaxially mounted, individually rotatable gears operatively connected with an hour hand of a timepiece with which the movement is associated. One of the gears is driven by the power train of the movement and the other of the gears is selectively operable manually by the usual winding stem to enable adjustment of the power hand according to the change of time zones. The gears are provided with magnetic means which normally couple the gears together for simultaneous rotation by the power train but permit manual adjustment of the one gear relative to the other to change the indication of the hour hand but without affecting any other hands such as the minute or second hands. Following the adjustment of the one gear by the winding stem or the like the magnetic means effects coincidence of the two gears to accurately position the hour hand in accordance with the minute and the second. The two gears preferably replace the usual hour gear in a movement of this type but they can replace the minute gear.

BRIEF DESCRIPTION OF THE DRAWING

FIG. 1 is a cross-sectional view taken on line 1—1 of FIG. 2 through a timepiece movement in accordance with the present invention;

FIG. 2 is a plan view partially in section taken on line 2—2 FIG. 1, and

FIG. 3 is a cross-sectional view similar to FIG. 1 but showing a modification.

The watch movement partially illustrated in the drawing includes a time unit wheel such as an hour wheel 1a, which is in mesh with the minute wheel pinion 2 of a power train including a minute wheel 3. The latter is rigidly connected with the minute wheel 3 which engages the cannon pinion 4. The cannon pinion 4 is frictionally mounted, in any conventional manner, on the center arbor 5. The hour wheel 1a is rotatably mounted on the cannon pinion 4 and center arbor 5.

On the cannon 6 of the hour wheel 1a is freely mounted an additional wheel 1b, which is identical with the hour wheel 1 and carries the hour hand 7. The minute hand 8 is carried in the usual manner by the cannon 4' of the pinion 4 and center arbor 5, whereas the second hand 9 is carried, in a manner known per se, by a spindle 10 extending through a bore in the center arbor 5 and rigidly secured to another wheel (not shown).

The additional wheel 1b is magnetically positioned with respect to the hour wheel 1a. To this end, 12 small permanent magnets 11 are inserted into the hour wheel 1a, these magnets being uniformly distributed about the axis of the wheel 1a. Twelve pieces 12 of soft iron, of the same size as the magnets 11, are secured in the additional wheel 1b, opposite the magnets 11.

Manually operable means 13 of known type may selectively rotate the additional wheel 1b by one or more pitches. By way of example, means 13 may be driven by a winding stem capable of taking, in addition to the usual winding and setting positions, a third position in which its actuation will drive means 13 to rotate the additional wheel 1b. Alternatively to this end a corrector of the type used in calendar watches may be used.

When the wheel 1b is rotated by one or more pitches, the hour hand 7 is also rotated, without influencing the indication given by the other hands 8 and 9. Thanks to the magnets 11 and to the pieces of soft iron 12, the wheel 1b always takes a correct angular position, the elements 11, 12 acting as a jumper-spring. The rotation of the wheel 1b, under the action of the actuating mechanism by an operator, is not transmitted to the hour wheel 1a, since the magnetic force exerted by the magnets 11 is not sufficient for overcoming the friction of the cannon pinion 4 on its arbor 5. However, upon the normal running of the watch, the rotation of the wheel 1a is transmitted without difficulty to the additional wheel 1b, since the latter is freely mounted on the cannon of the wheel 1a.

The magnets might also be mounted on the wheel 1b and the pieces of soft iron on the wheel 1a. It would also be possible to mount magnets on both wheels.

Furthermore, one or both wheels may comprise a magnetizable material and be magnetized so as to obtain 12 poles or pole pairs.

In a modified embodiment, FIG. 3, the identical pair of gears may comprise minute gears 3a, 3b, the gear 3a being an additional minute wheel controlling the hour hand by means of house gear 1, said additional minute wheel being magnetically positioned with respect to the usual minute wheel. The magnets and the pieces of soft iron would then be fixed to the minute wheels and, due to the gear ratio between the hour wheel and the minute wheel pinion, the number of these magnets might be reduced to four, for instance, if it is assumed that a quarter of a revolution of the minute wheel corresponds to a rotation of 30° of the hour hand. More generally, if the gear ratio between the hour wheel and the minute wheel pinion is denoted by n , the number of the permanent magnets and of the pieces of soft iron carried by the minute wheels, respectively, will be equal to $12/n$.

The device as illustrated and described might also be applied to a timepiece (watch or clock) with a dial having a scale of 24 hours. In this case, one of the hour wheels might take 24 positions with respect to the other one, or one of the minute wheels might take $24/n$ positions with respect to the other one.

What is claimed is:

1. A timepiece movement comprising a timer gear, an hour hand, another hand for indicating another segment of time, an additional gear controlling the hour hand and magnetically positioned with respect to said timer gear and controlling said hour hand, said additional gear being coaxial with said timer gear and actuated by operation of the timepiece movement and by means actuatable by an operator for rotating the additional gear by at least one pitch, thus correspondingly rotating the hour hand, without influencing the indication of the other hand.

2. A timepiece movement according to claim 1, wherein said gears consist of hour wheels.

3. A timepiece movement according to claim 2, wherein one of said gears carries twelve permanent magnets, uniformly distributed about its axis and, whereas the other gear carries twelve pieces of magnetic material arranged opposite said magnets.

4. A timepiece movement according to claim 1 wherein said gears comprise minute gears.

5. A timepiece movement according to claim 4, comprising an hour gear and the ratio between said hour gear and said minute gears is n , one of said minute gears carries $12/n$ permanent magnets uniformly distributed about its axis and the other minute gear carries $12/n$ pieces of magnetic material juxtaposed in correlation to said magnets.

6. A timepiece movement according to claim 1, wherein said gears comprise magnetizable material and are magnetized so as to obtain multiple poles.

7. A timepiece movement according to claim 3 wherein said magnetic material comprises soft iron.

8. A timepiece movement according to claim 3 wherein said magnetic material comprises permanent magnets.

9. A timepiece movement according to claim 5 wherein said magnetic material comprises soft iron.

10. A timepiece movement according to claim 5 wherein said magnetic material comprises permanent magnets.

11. A timepiece movement comprising a power train, a timer gear, an additional gear identical with said

timer gear and coaxially mounted for relative rotation therebetween, a rotatably mounted hour hand drivingly connected with one of said gears, another hand for indicating another segment of time and rotatably mounted coaxially with said hour hand, means connecting one of said gears with said power train to drive said gear for rotating said hour hand in the usual manner, manually operated means connected with the other of said gears for driving said gear to rotate said hour hand to change the hour indication thereof without affecting the other said hand, and magnetic means normally coupling said gears for maintaining angular coincidence therebetween, whereby said hour hand may be manually adjusted to change the hour indication thereof and the magnetic means will maintain the relative relation with respect to lesser time segments.

12. A timepiece movement according to claim 11 wherein said magnetic means comprises a like number of pole pieces carried by said gears, said pole pieces being equi-spaced about the axis of said gears according to a predetermined time segment and disposed to normally be substantially in coincidence.

13. A timepiece movement according to claim 12 wherein said gears are hour gears and there are twelve pole pieces in each said gear.

14. A timepiece movement according to claim 12 wherein said gears are minute gears.

* * * * *

30

35

40

45

50

55

60

65