

[54] **METHOD AND APPARATUS FOR UNIFORMLY ELECTROCOATING THE INTERIOR OF A SHAPED METAL CONTAINER**

3,476,667 11/1969 Gilchrist 204/181
 3,849,284 11/1974 Kossmann 204/300

Primary Examiner—Howard S. Williams
 Attorney, Agent, or Firm—John P. Taylor, Esq.

[75] Inventors: **David A. Smith**, Pittsburgh, Pa.;
Steven C. Smith, Arlington, Mass.;
John J. Davidson, New Kensington, Pa.

[57] **ABSTRACT**

A shaped metal container such as a can is uniformly electrocoated in an inverted position by the insertion of an electrically conducting nozzle therein through which coating material may flow into the interior of the container while an electrical potential is maintained between the container and the nozzle. The nozzle is shaped to direct flow of the material into the corners of the container as the nozzle is inserted and to maintain a transient bath type mode after the nozzle is inserted into the container. Coating material is delivered at a flow rate which permits the can to remain full in an inverted position. When the nozzle is removed the container empties without further mechanical operations.

[73] Assignee: **Aluminum Company of America**, Pittsburgh, Pa.

[22] Filed: **Oct. 23, 1974**

[21] Appl. No.: **517,326**

[52] U.S. Cl. **204/181**
 [51] Int. Cl.² **C25D 13/14**
 [58] Field of Search 204/181, 299 EC

[56] **References Cited**
UNITED STATES PATENTS

3,399,126 8/1968 Tunier 204/181
 3,476,666 11/1969 Bell et al. 204/181

12 Claims, 5 Drawing Figures

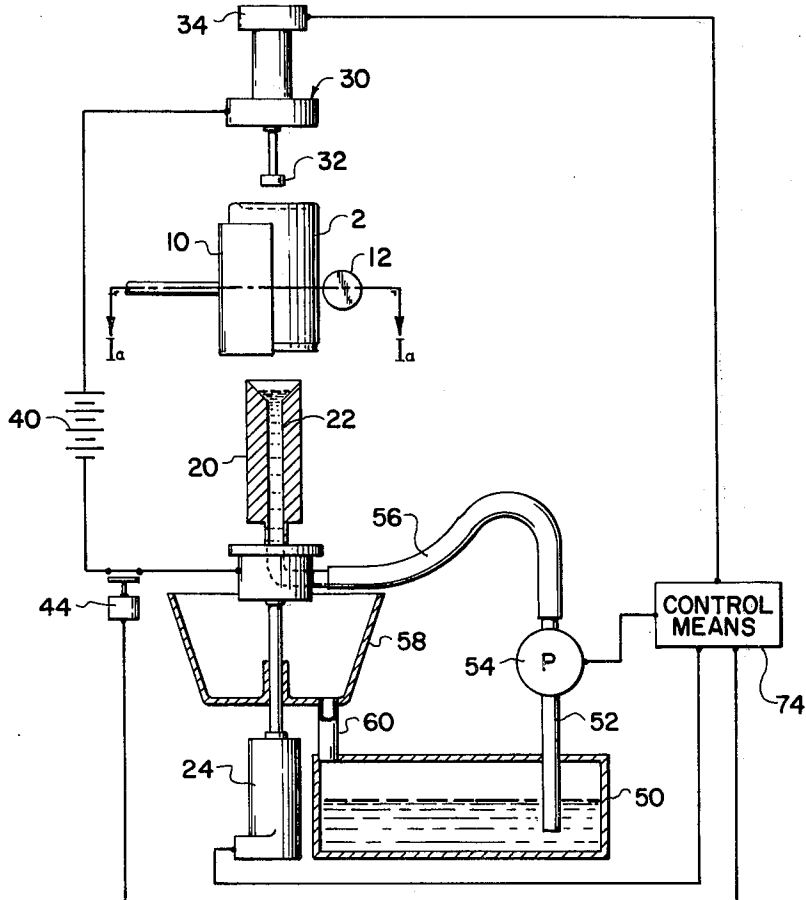

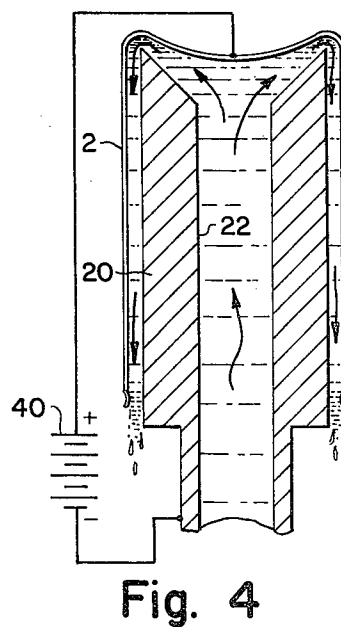
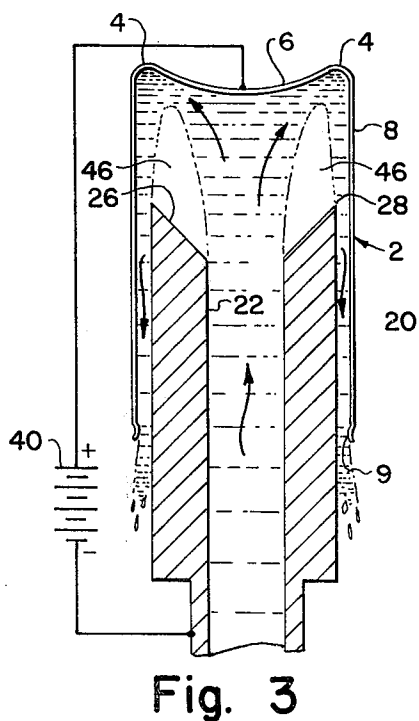
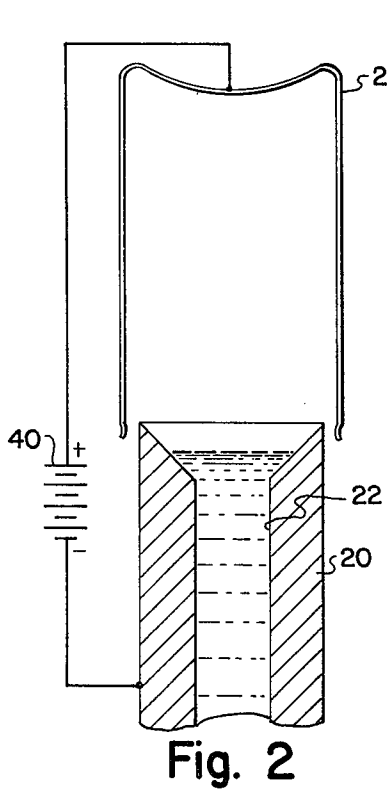
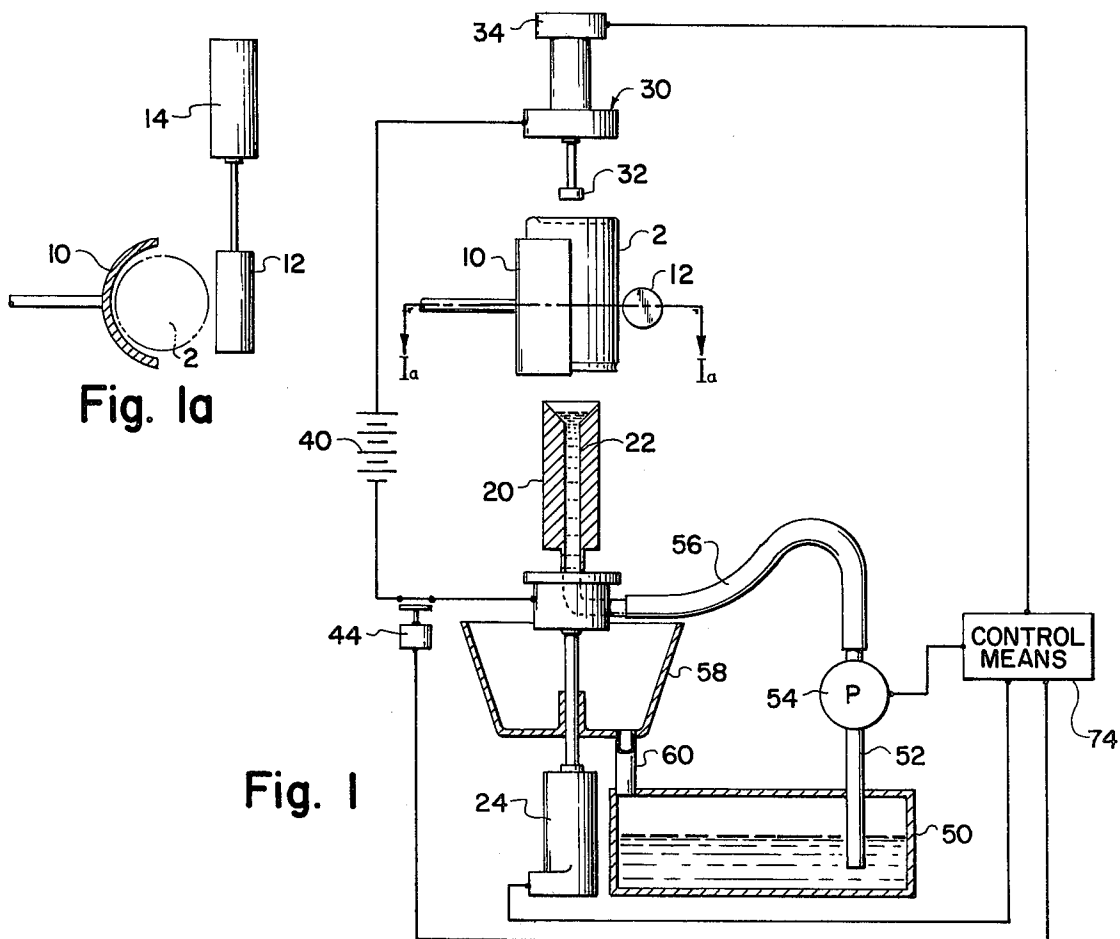

METHOD AND APPARATUS FOR UNIFORMLY ELECTROCOATING THE INTERIOR OF A SHAPED METAL CONTAINER

BACKGROUND OF THE INVENTION

This invention relates to the coating of a container. More particularly, this invention relates to electrocoating the interior of a shaped metal container.

The interior of containers such as cans or the like are usually coated with a material which will protect the contents of the container from reaction with the metal and conversely protect the metal from any attack by the contents. Usually, such materials are applied as sprays or the like using conventional paints having organic solvents therein. This requires preliminary cleaning of the container as well as subsequent drying to remove any liquid remaining from the rinsing portion of the cleaning operation. Furthermore some conventional coating systems require a pretreatment or a conversion coating of the metal, while others result in an uneven coating thickness and, in most instances, such coatings require solvent disposal for organic materials evolved in the coating during drying and baking.

Electrocoating type techniques for coating surfaces are, of course, known in the art. Usually, however, these involve immersion into a bath of coating material and such techniques are therefore not conducive to high speed production lines such as may be found in, for example, can making equipment. Furthermore, electrocoating processes normally rely on the insulating effect of the buildup of coated material on the surface of the article to ensure uniform coating. That is, the material continues to deposit on the surface of the article until a sufficiently thick insulating layer is built up across the entire surface. This coating buildup, again, takes a finite period of time which is longer than that which would be desirable in a high speed production line.

SUMMARY OF THE INVENTION

It is therefore an object of the invention to provide a system for electrocoating the interior of a container which is suitable for use in high speed production lines. This and other objects of the invention will be apparent from the drawings and description of the invention.

In accordance with the invention, a system is provided for uniformly electrocoating the interior of a shaped metal object which comprises inverting the container, inserting into the container an electrically conducting nozzle, flowing coating material through said nozzle into the interior of the container at a rate which permits the container to remain full in an inverted position, and simultaneously imposing an electrical potential between the container and the nozzle to cause the coating to electrocoat the interior of the container.

BRIEF DESCRIPTION OF THE DRAWINGS

FIG. 1 is a diagrammatic view partly in cross section of the system of the invention.

FIG. 1A is a top sectional view of a portion of FIG. 1.

FIGS. 2 to 4 are cross sectional views illustrating in step-wise manner the insertion of the nozzle into the container and the flow pattern of the coating material as it flows through the nozzle into the container.

DESCRIPTION OF THE INVENTION

In accordance with the invention a container such as the can illustrated at 2 in FIG. 1, is coated by the insertion therein of a coating nozzle 20. Can 2 is retained in an inverted position by a can holder 10 which comprises a U-shaped portion as best seen in FIG. 1A. The can is retained against the U-shaped portion by a restraining rod 12 which, on an assembly line, is moved against can 2 by suitable means 14 which may be an air cylinder or the like.

An anode assembly 30 is positioned above can 2 having an electrical contact portion 32 thereon. The anode assembly is electrically connected to the positive terminal of a power supply 40 which, in the illustrative embodiment, may be a battery or the like. After can 2 is positioned in can holder 10, suitable means 34, which may be an air cylinder or the like, moves the electrode contact portion 32 down into contact with the bottom portion of the exterior of can 2 to provide electrical contact thereto.

Coating nozzle 20 comprises a cylindrical conducting member having a center bore 22 therein through which coating material may flow. The coating material is pumped by pump 54 via conduits 52 and 56 from a tank 50 which is illustrated as positioned beneath the nozzle.

The external diameter of the coating nozzle 20 is selected, as best illustrated in FIGS. 2 to 4, to be slightly less than the interior diameter of the can to be coated. In a preferred embodiment, the difference between the external diameter of the nozzle and the internal diameter of the can is chosen to provide a cross sectional area which does not vary greatly from the cross sectional area of nozzle bore 22, for example not more than about 3 times the bore area. This permits the creation of a satellite or transient bath within can 2 to be achieved by a sufficient flow rate of coating into the can without the use of an unduly large pump resulting in a flooded condition thus permitting the entire interior surface of the can to be bathed and in constant contact with coating material. Alternatively, the desired flow rate may be achieved by increasing the fluid pressure in those instances where the nozzle bore is considerably smaller. Flow restriction means, as will be described in more detail below can also be used adjacent the exiting space between the nozzle and the can to achieve the desired flooded conditions by control of the exit flow rate.

Thus in a given instance wherein a 2.687 inch diameter can was coated with a 2 inch diameter nozzle, the nozzle orifice was 0.60 sq. in. and the difference between the nozzle cross-sectional area and that of the can at the point of the neck was 1.62 sq. in. With this difference in cross-sectional areas it was possible to maintain the can in a full condition with a flow rate of about 1 quart per second with about a 10 psi head.

Nozzle 20 is electrically connected to the negative terminal of power supply 40 to complete the circuit from can 2 through anode assembly 30 and power supply 40 via a relay 44. Simultaneous with the lowering of anode assembly 30 onto the external surface of can 2, nozzle 20 is raised by an appropriate means such as an air cylinder 24 to a point of insertion into the interior of can 2. As nozzle 20 enters can 2, relay 44 is activated by a control means 74 and the electrical circuit is completed and the pump 54 activated to begin flowing of

coating material through bore 22 into the interior of the container. This increases the coating time by using the time required for full insertion of the nozzle into the interior of can 2 to permit coating of the interior of the can to commence. Alternatively, completion of the electrical circuit can be delayed until full insertion of the nozzle into the can, if desired.

Activation of air cylinders 14, 24 and 34 as well as relay 44 and pump 54 are all controlled by a control means 74 depicted in block form. Control means 74 may comprise a computer or an electro-mechanical device such as timing motor equipped with a series of cams which mechanically activate relays. Such automation control means are well known to those skilled in the art and form no part of the instant invention.

As best seen again in FIG. 3, this initial commencing of the coating is prior to the establishment of what might be termed a fully flooded or bath-like condition as best seen in FIG. 4. As shown in FIG. 3, the area denoted at 46 are air pockets which are created by the shape of the nozzle 20. Nozzle 20 is provided with a concave-like surface 26 at the end thereof which terminates in a sharp circular edge 28 to direct the flow of coating material to the corner portions 4 of can 2. These portions, in the particular configuration of the can which is illustrated, would normally be the most difficult to coat because of the normal flow patterns as well as their spacing electrically from the end of the nozzle. By providing the sharp end pointedness of the nozzle 28 the throwing power of the bath to the corner portions 4 of the can are increased. Furthermore, by directing the flow of coating material via the concave portion 26 the flow of coating material to the end 6 of can 2 as well as to the corner portions 4 and the sidewalls 8 all portions of the can to be coated are provided with constant supply of coating material which does not deplete with the coating or plating out of the material as would be true of a static bath with no agitation or flowing of the liquid coating material. Air pockets are also avoided or eliminated by the flowing liquid which sweeps out any bubbles formed.

In the illustrated embodiment, can 2 is provided with an inner necked portion 9 adjacent the end of the can wall 8. This necked portion 9 is placed on the can to permit subsequent attachment of an end or lid to the can without increasing the overall diameter of the can at the seam or chime to facilitate close stacking. While we do not wish to be bound by any theory of operation, it appears that the neck 9 may provide a restraint for the flow of the material which assists in the maintenance of a bath-like condition as shown in FIG. 4 by decreasing the exit flow rate. While it is recognized that not all containers will have such a neck-like portion 9, this condition, if found to be desirable in other applications, may be simulated or duplicated by the provision of annular groove adjacent the bottom portion of the outer surface of nozzle 20. Such a groove could then be provided with an O-ring which would provide a similar restriction in the overall cross sectional area between the outside diameter of the O-ring and the inner diameter of the container to be coated. Such a construction would result in an additional benefit by the provision of electrical insulation at the point of closest proximity between can and nozzle thus protecting against any inadvertent shorting as well as inhibiting excessive build-up of coating thickness at that point.

In operation then, nozzle 20 is raised into the interior of can 2, the coating material flows from tank 50 via

conduits 52 and 56 by the action of pump 54 and, as material flows out of nozzle 20 into the interior of can 2 and down along the outer sidewalls 8 of can 2 to exit from the bottom of can 2. As the material flows out of can 2 it is caught in a catch basin 58 from which it flows via conduit 60 back into tank 50. Thus, very little of the coating material is wasted. In one embodiment the sidewalls of catch basin 58 may extend above the bottom of can 2 to provide a weir effect to insure coating of the bottom and end edge surface of the can.

After an increment as short as $\frac{1}{2}$ second the nozzle is retracted from can 2 via air cylinder 24 or the like, the material may still be permitted to flow, however, from nozzle 20 into can 2 as long as a portion of nozzle 20 is still inside can 2. Likewise, the current path is maintained between can 2 and nozzle 20 by maintaining anode assembly 30 in contact with the can until after cessation of the flow of electrocoating material. In this manner the coating time is extended to include the portions of time or increments of time required to both insert and retract the nozzle respectively into and out of can 2. This permits the uniform application of a sufficient amount of electrocoating material while permitting the coating operation to be carried out on a high speed coating line. For example, the nozzle and holder assembly 10 may be placed on a large conveyor belt or circular type of coating station provided with a plurality of such nozzles and holders, thus permitting a number of cans to be coated simultaneously as they move in circular fashion about a portion of the wheel containing the nozzle. Such arrangements are of course well known to those skilled in the art and are well known for use for example not only in the coating of containers but in the filling and sealing of such containers.

It should be noted here that, while as is stated above, normal coating techniques rely upon the buildup of a sufficient layer of coating on the wall or surface of the article to be coated to provide a uniform coating thereon by the creation of a sufficient and uniform insulation to provide a limiting film thickness, the present invention envisions the uniform application of a coating which may well be less than that which would provide such a limiting film thickness. However, the particular design of the nozzle and the flow pattern which is created thereby as well as the shape of the nozzle with regard to the shaped configuration of the can assists in the application of a uniform coating without the need to rely on the insulating properties of the deposited coating material. Thus, the nozzle may be withdrawn, the flow of coating shut off, and the electrical potential shut off by respective activation of cylinder 24, pump 54, and relay 44 to discontinue the coating of the container prior to the buildup of a sufficient thickness of coating to inhibit further electrocoating.

Thus, by the creation of a satellite or transient bath, applications have avoided the necessity for immersing the entire container into a coating bath wherein a certain amount of coating material would be deposited — and therefore wasted — on the outer surface of the container thus conserving coating material as well as permitting the coating station to be a part of a high speed production line used in forming and processing of cans or other containers or the like. Exotic and potentially slow mechanisms for emptying cans immersed in a bath are obviated. Furthermore, the flowing coating eliminates air pockets and assists in the formation of a uniform film on the container.

5

Having thus described our invention, what is claimed is:

1. A process for uniformly electrocoating the interior of a shaped metal container which comprises:

- a. inverting the container;
- b. inserting into the inverted container an electrically conducting nozzle;
- c. flowing coating material through said nozzle into the interior of said container at a flow rate sufficient to fill the container; and
- d. simultaneously imposing an electrical potential between said container and said nozzle to cause said coating to electrocoat the interior of said container interior.

2. The process of claim 1 wherein the configuration of said nozzle with respect to the configuration of said container permits said flowing of coating material through said nozzle into said container to create a flooded condition between said container and said nozzle to provide a transient bath.

3. The process of claim 2 wherein the outer configuration of said nozzle is in substantial conformity with the inner configuration of said container to provide a uniform spacing therebetween.

4. The process of claim 3 wherein said flow of coating and said imposition of an electrical potential between said nozzle and said container is discontinued prior to the buildup of a coating thickness sufficient to limit further electrocoating.

5. A process for uniformly electrocoating the interior of a shaped metal container which comprises:

- a. inverting the container;
- b. inserting into the inverted container an electrically conducting nozzle:
 - 1. said nozzle having a configuration with respect to the configuration of said container which permits said flowing of coating material through said nozzle into said container to create a flooded condition between said container and said nozzle to provide a transient bath; and
 - 2. said nozzle having outer configuration in substantial conformity with the inner configuration of said container to provide a uniform spacing therebetween;
- c. flowing coating material through said nozzle into the interior of said container at a flow rate sufficient to flood the interior of the container;
- d. simultaneously imposing an electrical potential between said container and said nozzle to cause said coating to electrocoat said container interior; and

6

e. discontinuing said flow of coating and said imposition of an electrical potential between said nozzle and said container prior to buildup of a coating thickness sufficient to limit further electrocoating.

6. An apparatus for uniformly electrocoating the interior of a shaped metal container which comprises:

- a. means for retaining said container in an inverted position;
- b. means for coating the interior of said container, said means including an electrically conducting nozzle insertable into said container, said nozzle having a passageway therein adapted to flow coating material into said container;
- c. means for simultaneously imposing an electrical potential between said container and said nozzle to cause said coating material to electrocoat said container interior; and
- d. means for discontinuing said flow of coating and said imposition of an electrical potential between said nozzle and said container prior to buildup of a coating thickness sufficient to limit further electrocoating.

7. The apparatus of claim 6 wherein the configuration of said nozzle with respect to the configuration of said container permits said flowing of coating material through said nozzle into said container to create a flooded condition between said container and said nozzle to provide a transient bath.

8. The apparatus according to claim 7 wherein the nozzle size is preselected with respect to the container size so that the difference between the inside cross-sectional area of said container and the outside cross-sectional area of said nozzle does not vary from the cross-sectional area of the nozzle bore by more than about 3 times the bore area.

9. The apparatus of claim 7 wherein a substantial portion of the sidewall of said nozzle is in substantial conformity with said container adjacent said nozzle sidewall to provide a uniform spacing therebetween.

10. The apparatus of claim 9 wherein at least one means to restrict the flow of the electrocoating from said inverted container is provided.

11. The apparatus of claim 10 wherein said means to restrict the flow of said electrocoating material is an inwardly directed projection on said container.

12. The apparatus of claim 10 wherein said means to restrict the flow of said electrocoating material from said container is an O-ring carried by said nozzle adjacent the end of said container.

* * * * *

55

60

65