



US 20020043551A1

(19) **United States**

(12) **Patent Application Publication**

**Payer et al.**

(10) **Pub. No.: US 2002/0043551 A1**

(43) **Pub. Date: Apr. 18, 2002**

(54) **SOLID-PHASE WELDED OPTICAL ELEMENT ATTACH PROCESS**

**Related U.S. Application Data**

(63) Continuation of application No. 09/707,721, filed on Nov. 7, 2000, which is a continuation-in-part of application No. 09/648,348, filed on Aug. 25, 2000.

(75) Inventors: **Robert L. Payer**, Pepperell, MA (US);  
**Livia M. Racz**, Belmont, MA (US)

**Publication Classification**

(51) **Int. Cl.<sup>7</sup>** ..... **B23K 1/06**; B23K 5/20;  
B23K 20/10; B23K 35/12

(52) **U.S. Cl.** ..... **228/254**; 228/110.1; 228/253

(57) **ABSTRACT**

A micro-optical component comprises an optical element for interacting with an optical beam and a mounting structure for attaching the optical element to an optical bench. This optical element is solid phase welded to the mounting structure. Solid phase welding has advantages in that it can be performed at lower temperatures than most soldering, even some eutectic soldering. Solid-phase welding, however, is much more robust during subsequent temperature cycling. This is especially important when the optical components undergo subsequent high temperature cycling.

Correspondence Address:

**J GRANT HOUSTON**  
**AXSUN TECHNOLOGIES INC**  
**1 FORTUNE DRIVE**  
**BILLERICA, MA 01821 (US)**

(73) Assignee: **AXSUN Technologies, Inc.**

(21) Appl. No.: **09/885,226**

(22) Filed: **Jun. 20, 2001**

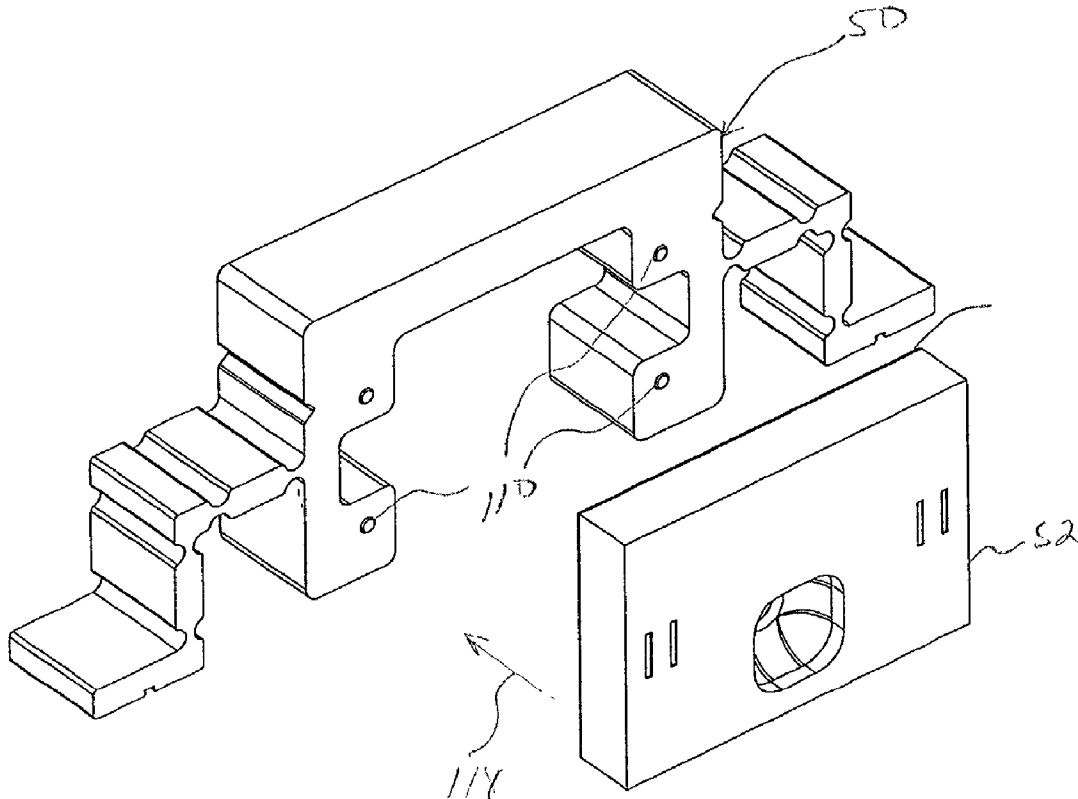

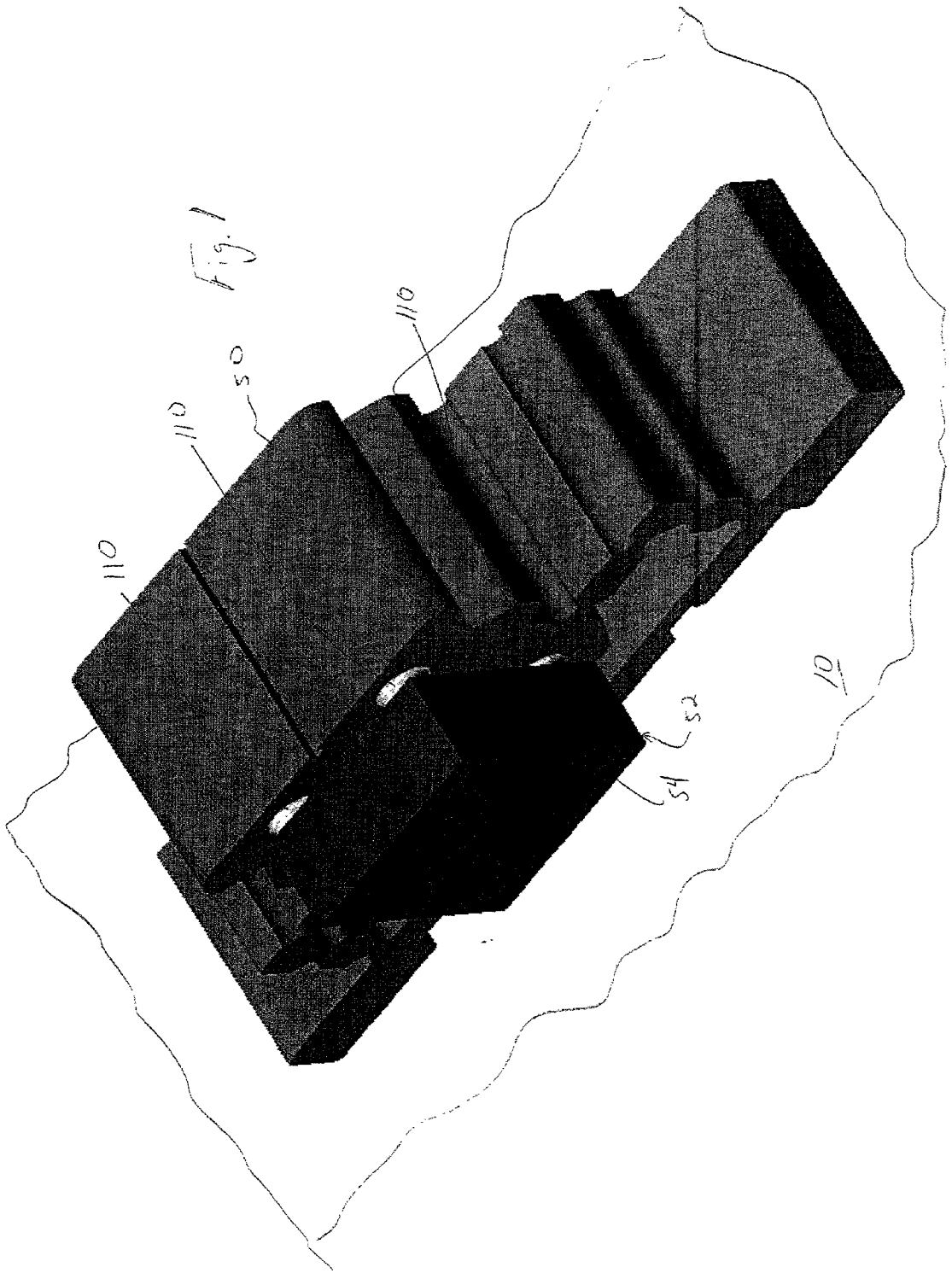

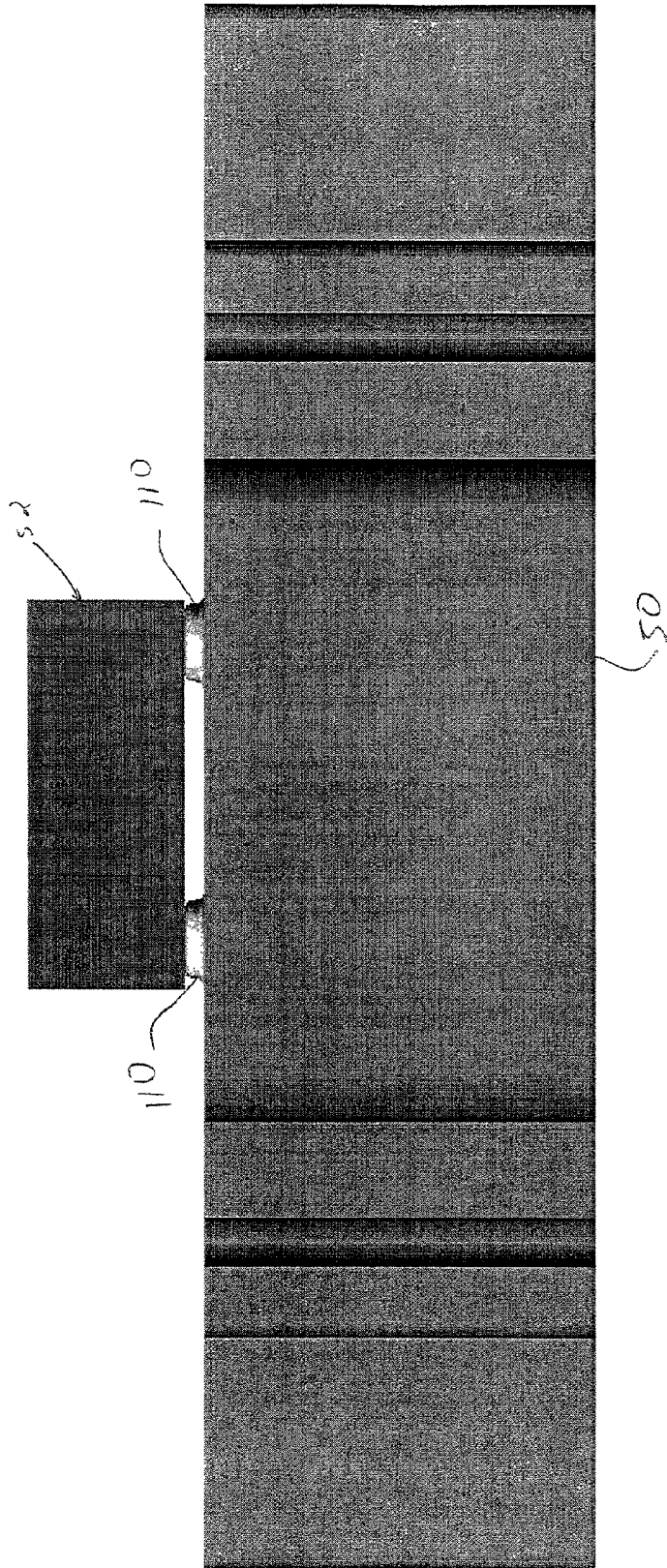
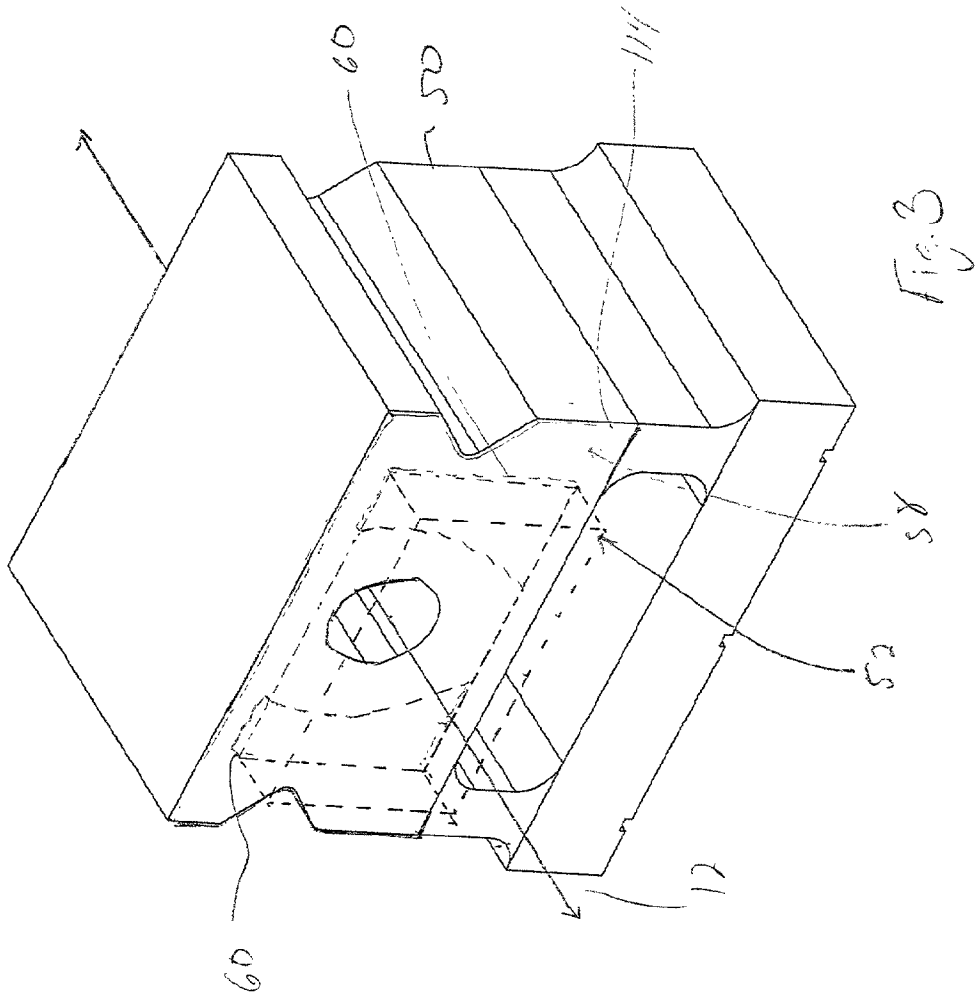

Fig. 2



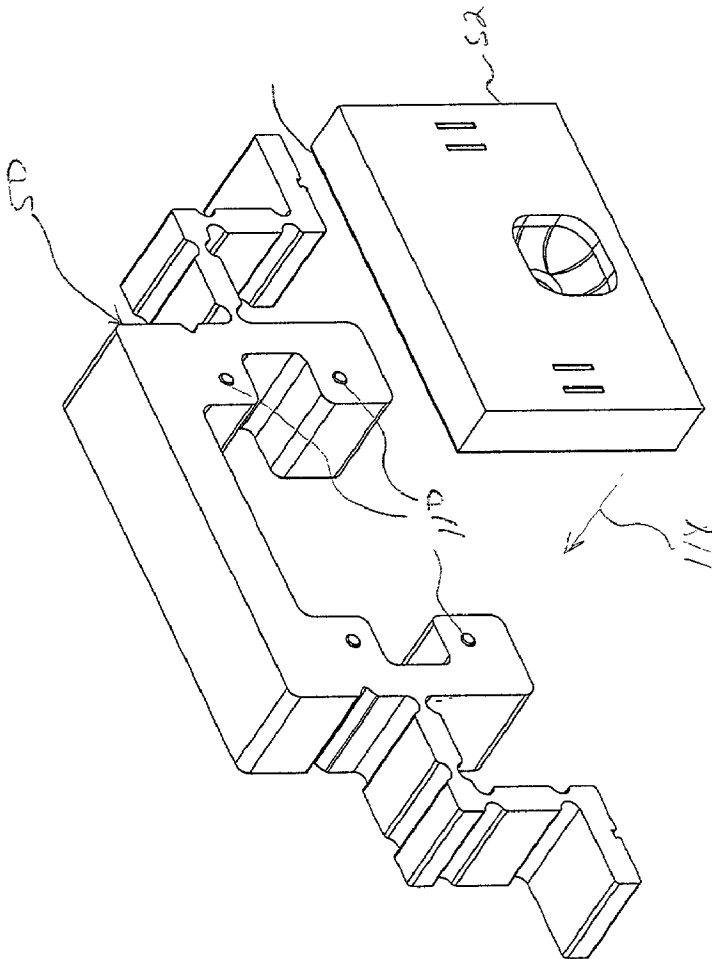

Fig. 4 A

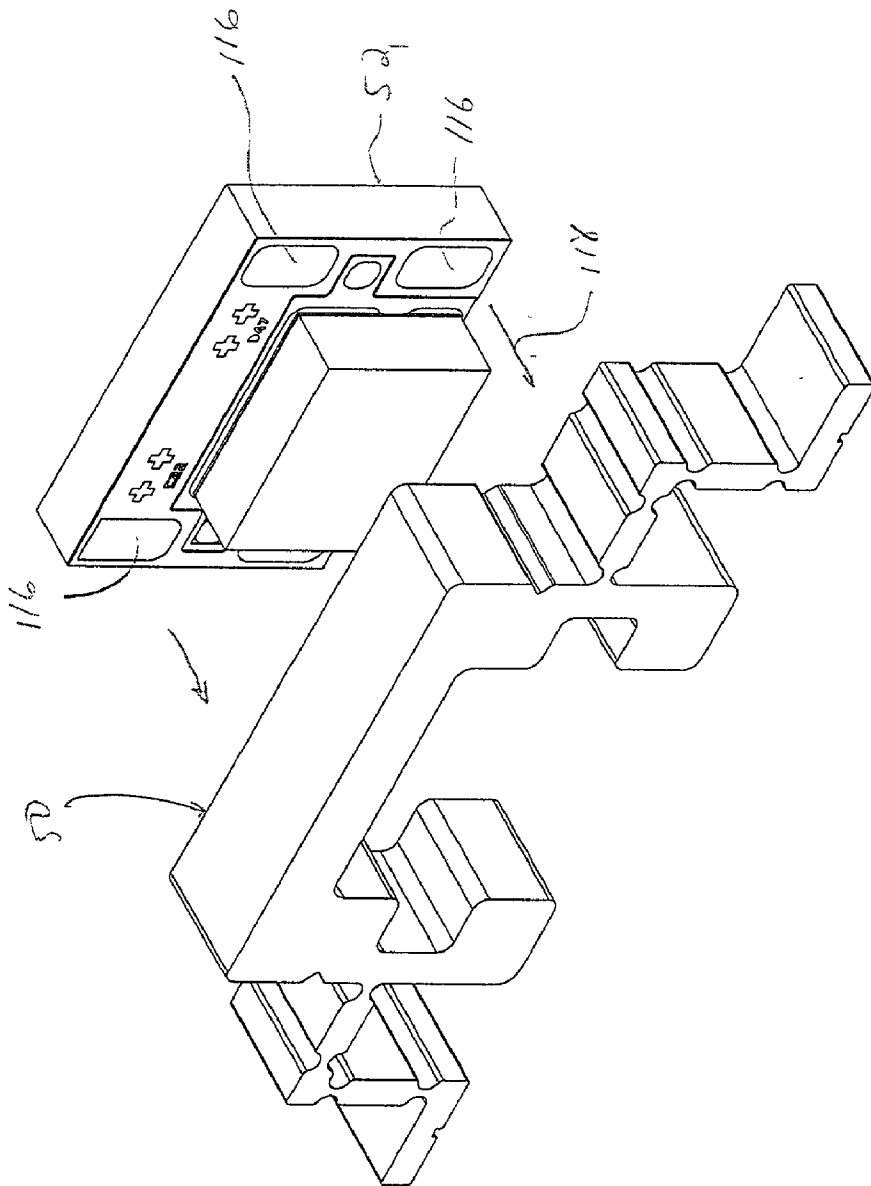
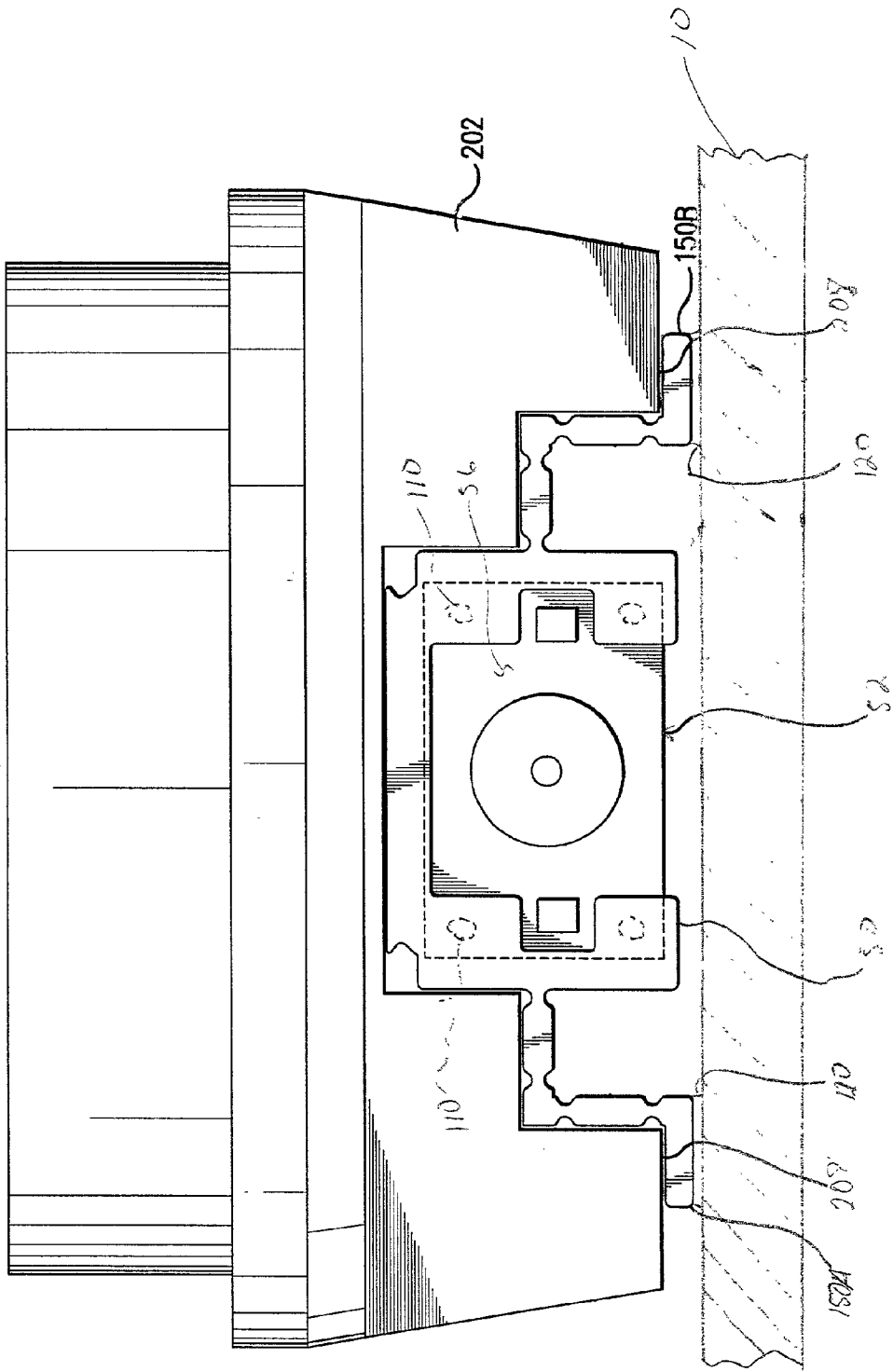

Fig. 4B

Fig. 5



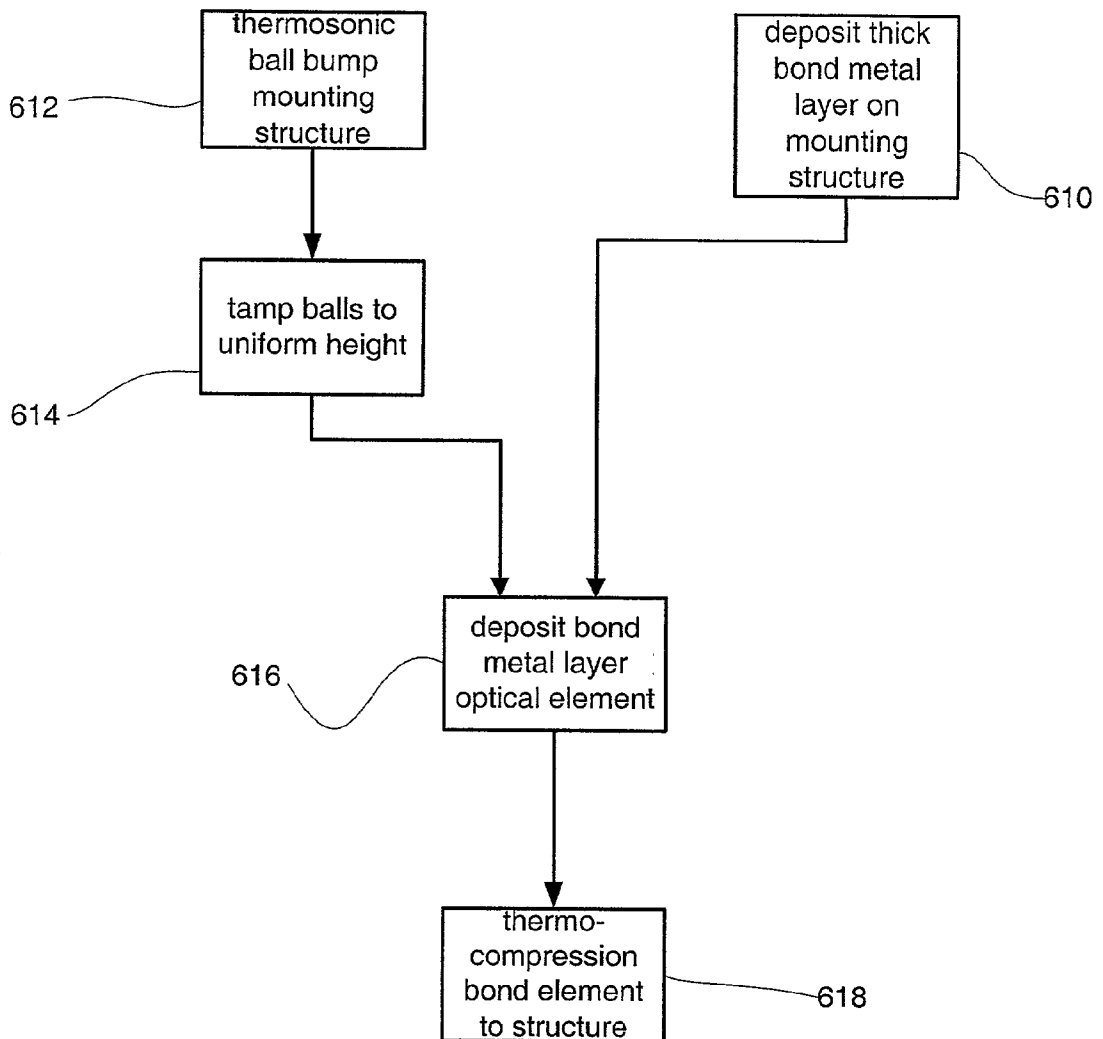

Fig. 6



## SOLID-PHASE WELDED OPTICAL ELEMENT ATTACH PROCESS

### BACKGROUND OF THE INVENTION

[0001] The packaging of fiber optic systems typically requires the installation of a free space optical element within a hermetic package. This is even required for integrated waveguide systems since light must be coupled across a free space link between the optical fiber endface and the waveguide "chip". In a typical configuration, the optical element is connected to an optical bench, sometimes also referred to as a submount.

[0002] In the packaging of these systems, especially within the hermetic package, metal-based bonding techniques are desirable and often required. Epoxy-based bonds generally are not robust across temperature and time. Moreover, out-gassed organics can damage optoelectronic components, such as semiconductor lasers. As a result, laser welding and solder bonding are the preferred optical element bonding techniques in fiber optic system manufacture.

[0003] A different class of metal bonding is referred to as solid-phase welding. Two metallic materials are brought into contact with heat, pressure, and/or ultrasonic energy. This results in electron sharing or interdiffusion of atoms, which forms a mechanical bond.

[0004] One type of solid phase welding is referred to as thermocompression bonding. The process involves two clean, ductile metals that are forced together and heated to a temperature less than their melting points. Gold is common bond metal, with aluminum, copper, or nickel being less common due to oxidation concerns. **Temperatures of between 300°-500° C. are common for gold welding. Welding to silicon is also possible with higher heat and pressures.**

[0005] In order to achieve tight contact between the bonding surfaces in thermocompression bonding, a very small mechanical scrubbing action can be used. Generally, the process takes place in a nitrogen environment to prevent oxidation.

[0006] Ultrasonic and thermosonic are two other examples of solid-phase welding. These welding processes can be performed at lower pressures and temperatures than thermocompression bonding, but require the addition of ultrasonic energy. Ultrasonic bonding can be performed at room temperature, whereas temperatures of **100-150° C. are common for thermosonic gold bonding.**

### SUMMARY OF THE INVENTION

[0007] Laser welding can be difficult to implement in fiber optic packaging production lines. A clear path to weld site is required. The required lasers are expensive and complex alignment/focusing tolerances require constant calibration. Moreover, the technique can be difficult to integrate with some optical elements because of the large thermal gradients associated with the process, and the concomitant residual material stresses can impact production yields. For example, laser welding is commonly used to attach optical elements such as optical fibers to clip mounting structures and the clips to a submount or bench. This process, however, requires that the optical fiber first be inserted through and

bonded to a tube to which the clip is welded since the silica fiber could be damaged if directly irradiated by the laser welder.

[0008] Solder-based joinery avoids some of the problems associated with laser welding. The joints, however, can have high residual material stresses and have exhibited poor performance in situations of high thermal expansion coefficient (TEC) mismatch between the optical element and the mounting structure. Moreover, eutectic solder joinery requires careful control over alloy compositions and typically depends on some diffusion to raise melting point so that the joint is robust against subsequent reflow cycles.

[0009] In contrast, solid phase welding has advantages in that it can be performed at lower temperatures than most soldering, even some eutectic soldering. Solid-phase welding, however, is much more robust during subsequent temperature cycling. This is especially important when the optical components undergo subsequent high temperature cycling.

[0010] In general, according to one aspect, the invention features a micro-optical component, which comprises an optical element for interacting with an optical beam and a mounting structure for attaching the optical element to an optical bench. This optical element, according to the invention, is solid phase welded to the mounting structure.

[0011] In the current embodiment, the element is thermocompression bonded to the mounting structure. In other implementations, thermosonic or ultrasonic welding are used, however.

[0012] In one example, the optical element comprises a lens substrate having an antireflection (AR) coated convex or concave lens formed in the substrate. In other examples, the optical element comprises a microelectromechanical device, such as a Fabry-Perot tunable filter, for example.

[0013] In the current implementation, the mounting structure includes a metal. Generally, these mounting structures are small. Currently, the LIGA fabrication process is preferred because of its ability to yield high aspect ratio structures. LIGA is a German acronym that stands for lithography, plating, and molding (lithographic, galvanofornung, abformung). Alternatively, other microforming fabrication processes are used to make the mounting structures. Laser machining, spark erosion, and deep reactive ion etching are alternatives.

[0014] In order to enable the solid phase welding, such as thermocompression bonding, the mounting structures are typically coated with a bond metal, if not directly fabricated in the metal. Currently gold is used. It can be sputtered, plated, or sonically deposited on the mounting structure. Alternatively, bond metal bumps are placed at discrete locations on the mounting structure and/or the optical element.

[0015] In general, according to another aspect, the invention also features a micro-optical system. The system comprises an optical element and a mounting structure. The optical element is solid-phase welded to the mounting structure. Thereafter, the mounting structure is solder bonded to the optical bench. This invention is important in this application, since the solid-phase welding can withstand the subsequent high temperature cycling associated with the solder bonding process.

[0016] In general, according to still another aspect, the invention features a process for assembling an optical system. This process comprises solid-phase welding an optical element to a mounting structure and then attaching the mounting structure to an optical bench by solder bonding, for example.

[0017] The above and other features of the invention including various novel details of construction and combinations of parts, and other advantages, will now be more particularly described with reference to the accompanying drawings and pointed out in the claims. It will be understood that the particular method and device embodying the invention are shown by way of illustration and not as a limitation of the invention. The principles and features of this invention may be employed in various and numerous embodiments without departing from the scope of the invention.

#### BRIEF DESCRIPTION OF THE DRAWINGS

[0018] In the accompanying drawings, reference characters refer to the same parts throughout the different views. The drawings are not necessarily to scale; emphasis has instead been placed upon illustrating the principles of the invention. Of the drawings:

[0019] FIG. 1 is a perspective view of an exemplary mounting structure with an exemplary optical element, which have been thermocompression bonded to each other, according to the present invention;

[0020] FIG. 2 is a top plan view of the welded mounting structure and optical element showing the bond metal bumps;

[0021] FIG. 3 is a perspective view of another exemplary mounting structure and optical element, which have been welded according to the present invention;

[0022] FIGS. 4A and 4B are perspective, exploded views of a MEMS tunable filter optical component;

[0023] FIG. 5 is an elevation illustrating the attachment of a MEMS optical component to a bench using a bonder; and

[0024] FIG. 6 is a process diagram illustrating a process for thermocompression bonding the optical element to the mounting structure.

#### DETAILED DESCRIPTION OF THE PREFERRED EMBODIMENTS

[0025] FIG. 1 shows an exemplary mounting structure with an exemplary optical element, which have been solid-phase welded to each other according to the present invention.

[0026] In the illustrated example, the mounting structure comprises a micro-fabricated metal frame. Currently, these are fabricated using the LIGA process. The bulk or plate metal is currently a nickel or nickel alloy, such as nickel iron.

[0027] Additional description of the mounting and alignment structures, and associated optoelectronic packaging technology is found in U.S. Pat. application Nos. 09/707,721, filed on Nov. 7, 2000 by Flanders, et al., and 09/648,348, filed on Aug. 25, 2000 by Masghati, et al., the teachings of these applications being incorporated herein by this reference in their entirety.

[0028] The exemplary optical element 52 comprises a substrate 54. In an example, the substrate 54 is a spectral filter substrate. In a more common example, a lens is formed in the substrate, such as a convex or concave lens. These lenses are currently manufactured using an etch process such as gray-scaling or a mass transport process. The optical element 52 is connected to the mounting structure 50 via bond metal bumps 110. Generally, a gold bond metal is used.

[0029] FIG. 2 better shows the profile of the bumps 110. In one implementation, the bumps are placed on the mounting structure using a wire bonder and subsequently tamped. During the thermocompression process, additional flattening occurs to ensure a robust bond between the optical element 52 and the mounting structure 50.

[0030] Returning to FIG. 1, the mounting structure 50 is in turn attached to an optical bench 10, sometimes referred to as a submount. In the current implementation, the preferred mode of attachment is a solder bond between the bench 10 and mounting structure 50.

[0031] FIG. 3 illustrates another example of a mounting structure and thermocompression bond. In this example, the mounting structure is not designed to be easily plastically deformable for a post installation alignment, for example. Further, in this example, discrete bond metal bumps are not placed on the optical element 52 or the mounting structure 50. Instead, a thick coating of compression bond metal 114 is placed at least on an optical element interface surface 58 of the mounting structure 50. A corresponding bond metal layer 60 is also selectively deposited on the optical element 52 to provide a robust metal-to-metal thermocompression bond interface. This bond metal layer on the optical element is preferably patterned to avoid obstructing an optical axis 12 of the optical element to thereby avoid interference between the bond metal and the optical signals that interact with the optical element 52.

[0032] FIGS. 4A and 4B illustrate still another example of a mounting structure 50. Geometry of this mounting structure is somewhat different to accommodate a relatively large MEMS optical element 52. In the illustrated example, this MEMS device 52 is an optical membrane or Fabry-Perot tunable filter as described in U.S. Pat. application Serial No. 09/797,529, filed on Mar. 1 2001, entitled "Integrated Tunable Fabry-Perot Filter and Method of Making Same", this application being incorporated herein by this reference.

[0033] As described previously, bond metal bumps 110 are deposited on the weld mating surfaces of the component interface of the mounting structure 50. Corresponding bond metal pads 116 are deposited on the weld mating surfaces of the MEMS optical element 52. The MEMS optical element is then solid-phase welded to the mounting structure using a combination of heat, pressure, and/or ultrasonic energy as illustrated by arrows 118. Currently, gold is the bond metal.

[0034] FIG. 5 also illustrates installation of the optical component mounting structure 50 onto the bench 10. Specifically, a chuck 202 of a pick and place bonder engages and picks-up the mounting structure 52, then places it on the bench 10. Solder preforms or predeposited solder pads 120 are located at the point of attachment or solder mating surfaces between the feet 150A, 150B of the mounting structure 50 and the bench 10. Heating element in the bonder chuck 202, for example, then raises the temperature of the

solder pads **120**, so that the solder is reflowed to thereby solder attach the mounting structure **50** to the bench **10**.

[0035] In another example, the mounting structure **50** is located on the bench manually and/or using a templating system. The solder pads **120** are then reflowed in a solder reflow oven in a batch process.

[0036] Shown in phantom are the thermocompression metal bumps **110** that connect the substrate **56** of the MEMS optical element **52** to the mounting structure **50**.

[0037] FIG. 6 illustrates a solid-phase welding process utilizing thermocompression bonding between the mounting structures **52** and the optical elements **52**.

[0038] Gold 5-8  $\mu\text{m}$  thick is deposited on the mounting structures **50** in step **610**, using a plating process for example.

[0039] Alternatively, if a ball bumping process is used, a therosonic ball bonder with a gold wire feed is used to form the bond metal bumps **110** on the mounting structure **50** or the optical element **52** in step **612**. Currently, 1.0 MIL gold wire is used with 0.5-3% elongation. The bumps **110** are two to three times the wire diameter in size. The stage temperature of the therosonic ball bonder is 130° C.  $\pm$ 5° C.

[0040] In step **614**, the bumps are tamped to a uniform height. Currently, a tamping tool with a head polished with diameter of 0.9 MIL and a tool angle 20-30° is used. The diameter of the bumps after tampling is 100 micrometers  $\pm$ 20 micrometers. The bump heights are 25 micrometers  $\pm$ 5 micrometers.

[0041] In step **616**, the bond metal layer is deposited on the optical element. Currently, a tri-metal system of 500 Angstroms Ti, 500 Angstroms Pt, and 5000 Angstroms Au is used for good adhesion.

[0042] Finally, in step **618**, the element is bonded to the structure. Currently, temperature of 320° C.  $\pm$ 2° C. for 3 minutes is used. The force is between 200 and 350 grams.

[0043] While this invention has been particularly shown and described with references to preferred embodiments thereof, it will be understood by those skilled in the art that various changes in form and details may be made therein without departing from the scope of the invention encompassed by the appended claims.

What is claimed is:

1. A micro-optical component, comprising:
  - an optical element for interacting with an optical beam; and
  - a mounting structure for attaching the optical element to an optical bench;
  - wherein the optical element is solid-phase welded to the mounting structure.
2. A micro-optical component as claimed in claim 1, wherein the optical element is thermocompression bonded to the mounting structure.
3. A micro-optical component as claimed in claim 1, wherein the optical element is therosonically bonded to the mounting structure.
4. A micro-optical component as claimed in claim 1, wherein the optical element is ultrasonically welded to the mounting structure.

5. A micro-optical component as claimed in claim 1, wherein the optical element comprises a lens substrate.

6. A micro-optical component as claimed in claim 1, wherein the optical element comprises a microelectromechanical device.

7. A micro-optical component as claimed in claim 1, wherein the optical element comprises a Fabry-Perot tunable filter.

8. A micro-optical component as claimed in claim 1, wherein the mounting structure is fabricated from a metal.

9. A micro-optical component as claimed in claim 1, wherein the mounting structure is metal coated.

10. A micro-optical component as claimed in claim 1, wherein the mounting structure is coated with a thermocompression bond metal.

11. A micro-optical component as claimed in claim 10, wherein the bond metal comprises gold.

12. A micro-optical component as claimed in claim 1, further comprising depositing bond metal bumps on the mounting structure.

13. A micro-optical component as claimed in claim 1, further comprising depositing bond metal bumps on the optical element.

14. A micro-optical system, comprising:

an optical element for interacting with an optical beam; a mounting structure, the optical element being solid-phase welded to the mounting structure; and

an optical bench, the mounting structure being solder bonded to the optical bench.

15. A micro-optical system as claimed in claim 14, wherein the optical element is thermocompression bonded to the mounting structure.

16. A micro-optical system as claimed in claim 14, wherein the optical element is therosonically bonded to the mounting structure.

17. A micro-optical system as claimed in claim 14, wherein the optical element is ultrasonically welded to the mounting structure.

18. A micro-optical system as claimed in claim 14, wherein the optical element comprises a lens substrate.

19. A micro-optical system as claimed in claim 14, wherein the optical element comprises a microelectromechanical device.

20. A micro-optical system as claimed in claim 14, wherein the optical element comprises a Fabry-Perot tunable filter.

21. A micro-optical system as claimed in claim 14, wherein the mounting structure is fabricated from a metal.

22. A micro-optical system as claimed in claim 14, wherein the mounting structure is metal coated.

23. A micro-optical system as claimed in claim 14, wherein the mounting structure is coated with a thermocompression bond metal.

24. A micro-optical system as claimed in claim 23, wherein the bond metal comprises gold.

25. A micro-optical system as claimed in claim 14, further comprising depositing bond metal bumps on the mounting structure.

26. A micro-optical system as claimed in claim 14, further comprising depositing bond metal bumps on the optical element.

**27.** A process for assembling an optical system, the process comprising: solid-phase welding an optical element to a mounting structure; and then attaching the mounting structure to an optical bench.

**28.** A process as claimed in claim 27, wherein the step of solid-phase welding the optical element to the mounting structure comprises thermocompression bonding the mounting structure and the optical element.

**29.** A process as claimed in claim 27, wherein the step of solid-phase welding the optical element to the mounting structure comprises thermosonically bonding the mounting structure and the optical element.

**30.** A process as claimed in claim 27, wherein the step of solid-phase welding the optical element to the mounting structure comprises ultrasonically bonding the mounting structure and the optical element.

**31.** A process as claimed in claim 27, wherein the step of attaching the mounting structure to the optical bench comprises solder bonding the mounting structure to the optical bench.

**32.** A process as claimed in claim 27, wherein the step of attaching the mounting structure to the optical bench comprises:

depositing solder material on solder mating surfaces of the mounting structure and the optical bench;

reflowing the solder material to join the mating surfaces.

**33.** A process as claimed in claim 27, wherein the step of solid-phase welding the optical element to the mounting structure comprises coating weld mating surfaces of the optical element and the mounting structure with bond material.

**34.** A process as claimed in claim 27, wherein the step of solid-phase welding the optical element to the mounting structure comprises coating weld mating surfaces of the optical element and the mounting structure with gold.

\* \* \* \* \*