

(19) World Intellectual Property Organization
International Bureau



(43) International Publication Date
7 April 2005 (07.04.2005)

PCT

(10) International Publication Number
WO 2005/030330 A1

(51) International Patent Classification⁷: A61N 7/02, 5/10

(21) International Application Number:
PCT/IB2004/051741

(22) International Filing Date:
10 September 2004 (10.09.2004)

(25) Filing Language: English

(26) Publication Language: English

(30) Priority Data:
60/507,634 30 September 2003 (30.09.2003) US

(71) Applicant (for all designated States except US): KONINKLIJKE PHILIPS ELECTRONICS, N.V. [NL/NL]; Groenewoudseweg 1, NL-5621 BA Eindhoven (NL).

(71) Applicant (for AE only): U.S. PHILIPS CORPORATION [US/US]; 1251 Avenue of the Americas, New York, New York 10020 (US).

(72) Inventors; and

(75) Inventors/Applicants (for US only): STECKNER,

Michael, C. [CA/US]; 595 Miner Road, Cleveland, Ohio 44143 (US). BOERNERT, Peter [DE/NL]; Groenewoudseweg 1, NL-5621 BA Eindhoven (NL). NEHRKE, Kay [DE/NL]; Groenewoudseweg 1, NL-5621 BA Eindhoven (NL).

(74) Common Representative: KONINKLIJKE PHILIPS ELECTRONICS, N.V.; c/o LUNDIN, Thomas, M. 595 Miner Road, Cleveland, Ohio 44143 (US).

(81) Designated States (unless otherwise indicated, for every kind of national protection available): AE, AG, AL, AM, AT, AU, AZ, BA, BB, BG, BR, BW, BY, BZ, CA, CH, CN, CO, CR, CU, CZ, DE, DK, DM, DZ, EC, EE, EG, ES, FI, GB, GD, GE, GH, GM, HR, HU, ID, IL, IN, IS, JP, KE, KG, KP, KR, KZ, LC, LK, LR, LS, LT, LU, LV, MA, MD, MG, MK, MN, MW, MX, MZ, NA, NI, NO, NZ, OM, PG, PH, PL, PT, RO, RU, SC, SD, SE, SG, SK, SL, SY, TJ, TM, TN, TR, TT, TZ, UA, UG, US, UZ, VC, VN, YU, ZA, ZM, ZW.

(84) Designated States (unless otherwise indicated, for every kind of regional protection available): ARIPO (BW, GH, GM, KE, LS, MW, MZ, NA, SD, SL, SZ, TZ, UG, ZM, ZW), Eurasian (AM, AZ, BY, KG, KZ, MD, RU, TJ, TM),

[Continued on next page]

(54) Title: TARGET TRACKING METHOD AND APPARATUS FOR RADIATION TREATMENT PLANNING AND DELIVERY

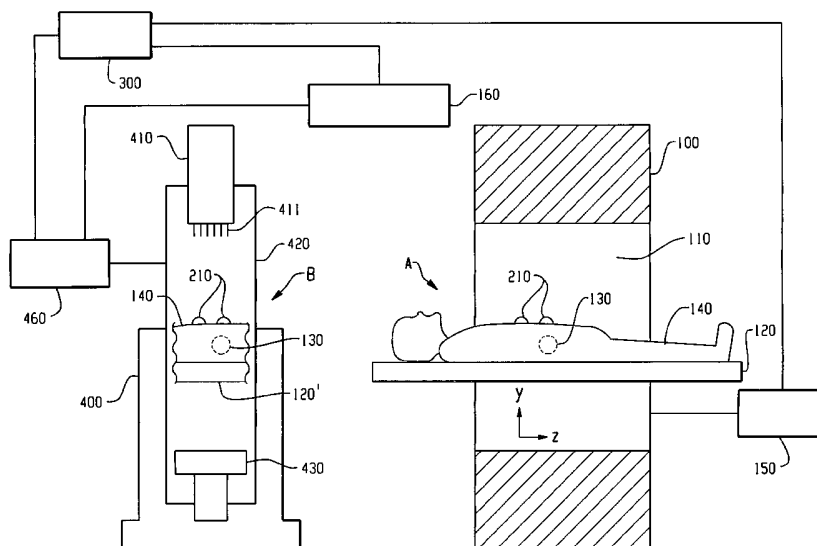

(57) Abstract: A target treatment apparatus for treating a target region (130) within a subject (140) is provided. The apparatus includes an MRI apparatus (100) for generating MR images during an MR scan of the subject disposed within an examination region (110). The apparatus further includes an MRI localizer (150) for receiving the image data from the MRI apparatus wherein the target (130) is localized and a reference marker localizer (160, 160') for non-invasively receiving reference data from a plurality of reference points disposed in proximity to the target wherein the reference points are localized. A tracking processor (300) is also included in the apparatus for receiving localized data from the MRI localizer wherein a relationship between the reference markers and the target region is generated.

WO 2005/030330 A1



European (AT, BE, BG, CH, CY, CZ, DE, DK, EE, ES, FI, FR, GB, GR, HU, IE, IT, LU, MC, NL, PL, PT, RO, SE, SI, SK, TR), OAPI (BF, BJ, CF, CG, CI, CM, GA, GN, GQ, GW, ML, MR, NE, SN, TD, TG).

ZW, ARIPO patent (BW, GH, GM, KE, LS, MW, MZ, NA, SD, SL, SZ, TZ, UG, ZM, ZW), Eurasian patent (AM, AZ, BY, KG, KZ, MD, RU, TJ, TM), European patent (AT, BE, BG, CH, CY, CZ, DE, DK, EE, ES, FI, FR, GB, GR, HU, IE, IT, LU, MC, NL, PL, PT, RO, SE, SI, SK, TR), OAPI patent (BF, BJ, CF, CG, CI, CM, GA, GN, GQ, GW, ML, MR, NE, SN, TD, TG)

Declaration under Rule 4.17:

— as to applicant's entitlement to apply for and be granted a patent (Rule 4.17(ii)) for the following designations AE, AG, AL, AM, AT, AU, AZ, BA, BB, BG, BR, BW, BY, BZ, CA, CH, CN, CO, CR, CU, CZ, DE, DK, DM, DZ, EC, EE, EG, ES, FI, GB, GD, GE, GH, GM, HR, HU, ID, IL, IN, IS, JP, KE, KG, KP, KR, KZ, LC, LK, LR, LS, LT, LU, LV, MA, MD, MG, MK, MN, MW, MX, MZ, NA, NI, NO, NZ, OM, PG, PH, PL, PT, RO, RU, SC, SD, SE, SG, SK, SL, SY, TJ, TM, TN, TR, TT, TZ, UA, UG, UZ, VC, VN, YU, ZA, ZM,

Published:

— with international search report

For two-letter codes and other abbreviations, refer to the "Guidance Notes on Codes and Abbreviations" appearing at the beginning of each regular issue of the PCT Gazette.

TARGET TRACKING METHOD AND APPARATUS FOR RADIATION TREATMENT PLANNING AND DELIVERY

DESCRIPTION

5 The present invention relates to the medical imaging arts. It finds particular application in conjunction with medical imaging in MRI scanners for oncological applications and will be described with particular reference thereto. It will be appreciated, however, that the invention is also applicable to other types of interventional procedures and for other imaging for other purposes.

10 In planning an interventional procedure, an oncologist typically generates a plurality of images, such as x-ray projection images, of a region to be treated. The images show bone and other internal structures, but do not necessarily differentiate the tumor from non-cancerous tissue. However, from *a priori* knowledge of anatomy and the nature of the tumor, the oncologist estimates the center of the tumor and its extent.

15 One of the factors in planning oncological procedures is accurately aligning an interventional tool with the internal tumor. In one case, the interventional tool is a linear accelerator (linac) which emits a high energy x-ray beam for use in radiation therapy. Another interventional tool is a focused ultrasound which emits a high power ultrasonic beam that is used to heat abnormal tissue to the point that it is destroyed, or ablated. In
20 either case, the oncologist aligns the tool with the internal tumor. If the selected trajectory is even slightly off, the x-ray or ultrasonic beam might treat most of the tumor, but may leave a portion of the tumor untreated and may undesirably affect otherwise healthy tissue.

 Accordingly, the oncologist typically determines a plurality of trajectories through the tumor which miss neighboring tissue or attenuating bone. Once the trajectories and
25 points of entry into the subject have been determined, the oncologist positions the tool to aim its beam to enter the subject at the selected point of entry and follow a selected trajectory.

 The more precisely the size, shape, and position of the tumor are known, the more precisely the treatment beam can be shaped to minimize the exposure of surrounding tissue
30 while assuring the treatment of all cancerous tissue. However, because the oncologist is estimating the extent and location of the tumor without precise visual confirmation, the treatment beam is typically wider than necessary to assure all cancerous tissue is affected. In the case of the linac, the x-ray beam is collimated to have a diameter slightly larger than

the tumor to be irradiated. Making the diameter of the beam too large may undesirably irradiate otherwise healthy tissue, however. On the other hand, making the beam diameter smaller increases a probability that cancerous tissue misses being irradiated. The same is analogously true for focused ultrasound.

5 Tumor motion, along with size and location of the tumor, can also be a factor in planning oncological procedures when it comes to accurately aligning an interventional tool with an internal tumor. For example, a tumor may move due to respiratory motion during treatment. Here, clinical practice has been to identify the tumor then add a margin around the tumor that accounts for tumor motion. The larger the degree of motion, the
10 larger the margin is made in an attempt to ensure that during treatment the entire tumor is irradiated. As discussed above, a consequence of this added margin can be that healthy tissue can be adversely exposed to treatment.

Gating the intervention with respect to such motion has been used in an effort to reduce the margin size and thus reduce the amount of healthy tissue that is otherwise
15 exposed to treatment. In the case of radiation and ultrasound therapy, the delivery of treatment is gated, or selectively turned on or off in response to a gating trigger.

Typical gating triggers, in cases in which respiratory motion is an issue, include bellows to measure the expansion of the chest, breathing sensors which indicate stages of the breathing cycle, or a fiducial marker placed on the subject. Here, the treatment beam is
20 shut off during stages outside the desired portion of the breathing cycle. Unfortunately, gating prolongs the time required for each treatment session since the treatment is not delivered continuously. Another drawback to these gating technologies is that they are largely one dimensional and correlation between tumor position and a 1D measurement is not particularly strong.

25 Tumor tracking has also been used in an effort to reduce the margin size associated with tumor treatment procedures. Here, to track the movement of the target, one or more internal markers have been attached to or placed near various locations on or near the target organ. Then, as the target moves, the internal markers also move. From the placement of the internal markers, it is possible to determine the position of the target
30 using imaging techniques such as x-ray or ultrasound.

A drawback to this method of tumor tracking, however, is that it involves the invasive procedure of implanting the internal markers. In addition, the internal markers can migrate over time, thereby producing misleading information.

5

Those skilled in the art will, upon reading and understanding the appended description, appreciate that aspects of the present invention address the above and other matters.

In accordance with one aspect of the invention, a target treatment apparatus for treating a target region within a subject is provided. The apparatus includes an MRI apparatus for generating MR images during an MR scan of the subject disposed within an examination region, an MRI localizer for receiving the image data from the MRI apparatus wherein the target is localized, a reference marker localizer for non-invasively receiving reference data from a plurality of reference points disposed in proximity to the target wherein the reference points are localized, and a tracking processor for receiving localized data from the MRI localizer wherein a relationship between the reference markers and the target region is generated.

In accordance with another aspect of the invention a method of treating a target region within a subject is provided. The method includes generating magnetic resonance images of the subject disposed within an examination region, localizing the target region from the MR images, non-invasively localizing a plurality of reference points disposed in proximity to the target, and generating a relationship between the reference markers and the target region.

In accordance with another aspect of the invention, an apparatus for treating a target region within a subject is provided. The apparatus includes means for generating magnetic resonance images of the subject disposed within an examination region, localizing means for localizing the target region from the MR images, reference means for non-invasively localizing a plurality of reference points disposed in proximity to the target, and modeling means for generating a relationship between the reference markers and the target region.

One advantage of an embodiment of the invention is that a need for directly tracking a target tissue is reduced.

Another advantage of an embodiment of the invention is that restriction of subject movement is reduced.

Another advantage of an embodiment of the invention is that it facilitates target position predictive accuracy.

5 Another advantage of an embodiment of the invention is that it facilitates the reduction of treatment margins.

Another advantage of an embodiment of the invention is that it facilitates a reduction in radiation doses in treatment sessions.

10 Another advantage of an embodiment of the invention is that it facilitates a reduction in duration of treatment sessions.

Another advantage of an embodiment of the invention is that it facilitates locating internal subject structures during treatment sessions.

Another advantage of the present invention is that it is non-invasive.

15 Still further advantages of the present invention will become apparent to those of ordinary skill in the art upon a reading and understanding of the following description of the preferred embodiments.

The invention may take form in various components and arrangements of
20 components, and in various steps and arrangements of steps. The drawings are only for purposes of illustrating a preferred embodiment and are not to be construed as limiting the invention.

Figure 1 is an illustration of a target treating apparatus.

Figure 2 is an illustration of an MRI localizer showing an axial view of a subject.

25 Figure 3 is an illustration of a reference marker localizer.

Figure 4A is a frontal view of a section of a subject with fiducial markers placed thereon.

Figure 4B is an axial view of a section of a subject with fiducial markers placed thereon.

30 Figure 4C is a side view of a section of a subject with fiducial markers placed thereon.

Figure 5 is an illustration of a target treating apparatus which utilizes fiducial markers and a pressure transducer.

Figure 6 is an illustration of a target treating apparatus which utilizes navigators for target tracking.

5 Figure 7 is a frontal view of a section of a subject showing localized points for target tracking.

With reference to FIG 1, a target treating apparatus is shown. As shown, the
10 apparatus may serve as an oncological apparatus for the treatment of cancerous tissue, or tumors. The apparatus includes a magnetic resonance imaging (MRI) system 100. The MRI system in the illustrated embodiment is a cylindrical-type system. More specific to the embodiment shown, the MRI system is a horizontal field MRI system which generates a horizontal magnetic field through an imaging region 110 along the axis of its bore. A
15 subject support 120 is movable in to and out of the bore to position a region of interest 130 of a subject 140 in the imaging region 110 as indicated by position A in FIG 1. In the embodiment shown, external reference, or fiducial, markers 210 are placed on the subject such that they are positioned within the imaging region 110 and in a desired proximity to the region of interest 130. In the embodiment shown, the fiducial markers are compatible
20 with the magnetic fields associated with magnetic resonance imaging and optionally are selected so as to appear on images generated by the MRI apparatus. With respect to the MRI apparatus 100, alternately, an open field MRI system can be used.

The apparatus also includes an MRI localizer 150 for processing images generated by the MRI system. The localizer localizes the region of interest 130, such as an internal
25 tumor, and optionally the reference markers 210. As shown in FIG 2, the MRI localizer may include such items as a human readable display 151, a pointing device 152, such as a computer mouse or trackball, a keyboard (not shown), and other image processing tools as are known in the relevant art.

In the embodiment shown in FIG 2, an axial cross section of the subject 140 is
30 shown on the display 151. The cross-sectional image shows the tumor 130 and, optionally, the fiducial markers 210.

Turning back to FIG 1, the treatment apparatus also includes a reference marker localizer 160 for localizing the reference marker positions. In one embodiment, as shown in FIG 3, the reference marker localizer includes two video cameras 161₁, 161₂ positioned to capture video images of the reference markers 210 from within the examination region 110. Here, the markers can be light reflective. Alternately the markers can emit a light signal, an infrared signal, or other signal that can be detected by the video cameras. It is to be understood that while FIG 3 shown two video cameras, an alternate number of cameras may be chosen so long as the positions of the markers 210 can be determined in three dimensions.

Continuing with FIG 3, the reference marker localizer 160 also includes a video processor 162. The video processor 162 is connected to the video cameras and includes processors and controls for processing images received therefrom and for identifying the reference markers 210 from the images, as is known in the art. It is also to be understood that other types of position sensing systems, such as audio signal detector with audio signal emitting markers, are contemplated.

Returning to FIG 1, the MRI localizer 150 and the reference marker localizer 160 pass data regarding the localization of the tumor 130 and the reference markers 210, respectively, to a tracking processor 300. The tracking processor includes a processor that generates a model relating the position of the tumor with respect to the external markers.

The tracking processor is also connected to a treatment controller 460 for transferring the model information thereto. The treatment controller is connected to a treatment tool 400 for controlling a treatment of the subject as more fully described below.

Continuing with FIG 1, the treatment may be carried out when the subject is within a treatment region of the interventional tool 400, as indicated by position B in FIG 1. (For the sake of simplicity, a section the subject is shown in position B.) In the embodiment shown, the interventional tool includes a linear accelerator 410, a supporting C-arm 420, and an X-ray detector 430.

In the embodiment shown, the reference marker localizer 160 is used to receive information regarding the external reference markers 210 and processes such data to generate reference marker localization data from position B. This localization data is passed to the treatment controller 460. The treatment controller 460 uses the model

information in conjunction with the position B reference localization data to control the treatment tool 400 in accordance with a desired treatment of the tumor 130.

5 In operation, a given number of fiducial markers 210 are placed on the subject as shown in FIGS 4A-4C. As can be seen, the markers are placed on the subject 140 in the vicinity of the target tissue to be treated 130. In one embodiment, the markers are randomly placed on the subject. In another embodiment, the markers are evenly positioned on the subject. In still another embodiment, the markers are placed on known landmarks of the subject. Also, in the embodiment shown, fifteen markers are placed on the subject, however more or less markers may be used as desired.

10 Once the markers 210 are positioned, the subject is placed on the subject support 120 of the MRI apparatus 100 and the subject is positioned in the examination region 110. As shown in FIG 1 and FIGS 4A-4C, the tumor 130 is in the abdominal region and the markers 210 are placed on the abdominal and thoracic regions. It is to be appreciated, however, that the positions of the tumor and markers are not limited to these regions.

15 An MRI examination is then carried out on the subject. In one embodiment, a cine study is performed using the MRI apparatus and applying known imaging techniques to image the target tissue 130. Concurrently, the reference marker localizer 160 collects data with respect to the reference markers 210. Here the target tissue 130 and the reference markers 210 can be imaged during dynamic activity, such as subject breathing or other
20 movement that would cause a predictable movement of the tumor with respect to the fiducial markers. The examination is performed for a duration of, for example three minutes, during which time, the subject breathes normally. It is to be understood that the duration of the examination can be more or less than three minutes depending on the amount of cine image data that is desired. It is also to be understood that rather than
25 breathing normally, the subject may breathe in an alternate prescribed manner.

After this preparatory scan is completed, the image data are displayed statically on the MRI localizer. Here, the tumor position is identified using known oncological procedures, such as contouring. Contouring is performed by the operator using the pointing device 152 to draw contours, or place other marks, around the tumor in a given
30 number of images displayed on the display 151. From the tumor identification data, a tumor isocenter can then be identified in the MR images.

In addition to the tumor, the fiducial markers are also identified and uniquely labeled. The markers are optionally identified by the user or automatically as is known in the art, via the reference marker localizer 160.

5 In an alternate embodiment, the reference markers 210 appear on the MR cine images and are displayed on the MRI localizer. Here, the reference markers are localized by the operator using the pointing device 152 to mark the fiducials as they appear on the display 151.

10 Once the tumor and the fiducial markers have been localized as described above, the localization data are passed to the tracking processor 300. In one embodiment, the tracking processor calculates distances, for example Δx , Δy , and Δz , between the tumor isocenter and individual fiducial markers. The tracking processor then performs a correlation between the distances and the markers. A look-up table is then generated such that for a given position of a fiducial marker, or markers, the position of the tumor isocenter can be found.

15 In another embodiment, tumor position is generated as a function of fiducial marker position for the individual markers. The function may be a linear function. It may also be non-linear and may include cross-terms (e.g. motion of the tumor in the x-direction may be a function of, *inter alia*, motion of a given fiducial in the y-direction).

20 In one embodiment, the tracking processor identifies three fiducials which most accurately predict the tumor position with respect to the fiducials. In other words, a first fiducial is identified for tracking tumor motion in the x-direction, a second fiducial is identified for tracking tumor motion in the y-direction, and a third fiducial is identified for tracking tumor motion in the z-direction. In this way, three external fiducials can be used to predict the position of the tumor.

25 Those skilled in the art will recognize that better tracking may be realized by using several fiducials per axis to gain better predictive tumor position results. Also, by performing the MRI cine study for several minutes, a statistical degree of confidence can be built up which confirms that there is a good correlation between tumor isocenter and the external fiducials. Regardless of the parameters of the cine study and tracking/modeling method, the tracking processor produces a mathematical tracking model which describes
30 the relationship between the fiducial positions and the tumor position. The model

parameters are then sent to the treatment controller 460 and the treatment protocol is carried out as described more fully below.

Once the parameters of the tracking model have been determined, and optionally the markers to be used to predict the position of the tumor have been selected, the other
5 fiducials can be removed as desired. The subject is then placed in position B such that the location of the fiducials can be monitored and the tumor can be treated by the interventional tool 400.

For the embodiment shown in FIG 1, during a radiation treatment session, the positions of the fiducials are monitored in real time by the reference marker localizer 160.
10 Once the fiducials have been localized, the related position information is passed to the treatment controller 460. The treatment controller then uses the fiducial positions as input to the tracking model generated by the tracking processor 300 to predict the position of the tumor during treatment.

Typically, an oncology linac x-ray system such as that shown in FIG 1 includes
15 three inputs: gantry, table, and collimator. The gantry input specifies an angular orientation of the C-arm 420 around the subject and a canting of the plane of the C-arm relative to a longitudinal axis of the subject. The table of an oncology linac system can typically move in three directions, up-down, longitudinally back and forth, and canting relative to a longitudinal axis of the subject. Finally, the collimator input adjusts the angle
20 of a collimator 411 and a size of an aperture of the linac 410. This makes the beam of x-rays wide or narrow, depending on the desired path and diameter.

Accordingly, as the fiducials move, the treatment controller uses the fiducial position information to control the inputs to the treatment tool 400 so that the treatment can be directed at the target more accurately than if the treatment tool were not so controlled.

25 In another embodiment, a model is developed which predicts rotations of the tumor separately or in conjunction with the motion of tumor isocenter. As with the motion model described above, the external fiducial markers are used to make such prediction. The treatment tool is then controlled as described above, taking into account such rotation.

In another embodiment, a model is developed which predicts distortions of the
30 tumor separately or in conjunction with rotation and motion. As with the motion model, the external fiducial markers are used to make such prediction. The treatment tool is then controlled as described above, taking into account such distortion.

In another embodiment, the MR cine study is performed prior to each radiation treatment session so that tumor shrinkage, body mass and/or shape changes can be accounted for.

In yet another embodiment, external transducers other than the fiducial markers are used to facilitate the accuracy of the tumor position model described above. For example, as shown in FIG 5, a pressure sensor 500 is placed under the subject. The pressure data are synchronized with the MRI data for the tumor and the fiducial markers and changes in weight distribution throughout the breathing cycle is used as input into the tracking processor. The tracking processor then uses the pressure data, along with the fiducial marker data to create the model of target motion. Other types of external transducers that are contemplated include traditional gating bellows, breathing sensors attached to the nose/mouth, ECG signals, and Vector ECG signals.

In yet another embodiment, as shown in FIG 6, rather than using external markers as described above, the position of the region of interest 130 can be predicted non-invasively using MR navigators. As can also be seen in FIG 6 an interventional tool 400' is located within the examination region 110 of the MRI apparatus 100 and in proximity to the target 130. Here, the interventional tool can be a focused ultrasound device situated under the subject 140 and in the subject support 120. More specifically, the ultrasound device can be a phased-array transducer where multiple focal points can be treated simultaneously and/or transducers can be controlled to follow the motion of a target as described herein. Alternately, a focal point of an ultrasound device can be moved to follow a target.

In one embodiment, the MR scanner is a 1.5T system equipped with an MR compatible 14-ring spherical ultrasound transducer integrated in the bed of the MR system. The ultrasound transducer includes an operating frequency of 1.5 MHz, an aperture diameter of 96 mm, a radius curvature of 130 mm, and a maximum acoustic power of 44 W averaged over the electric duty cycle. The ultrasound probe can be hydraulically moved in a horizontal plane with a spatial resolution of 0.25 mm in each direction, covering an 80 x 80 mm square. The focal length associated with this embodiment can be adjusted from 80 to 150 mm. It is to be understood that other operating parameters for the MRI system and ultrasound device are contemplated and can be selected as necessary.

In a preparation phase, the MRI apparatus 100 generates images of the subject which include the subject's diaphragm 170 and the target tissue 130. Various points, or contours, on the diaphragm 170 and target tissue are then identified on the MRI localizer 150. Accordingly, in this embodiment, it is understood that the reference localizer 160' can be integrated into the MRI localizer as shown in FIG. 6. As shown in FIG 7, point D1 is identified on the diaphragm and points T1, T2, T3, and T4 are identified on the target tissue. It is to be understood that more or less points can be identified on the diaphragm and target as desired. It is also to be understood that other structures, such as the chest wall, can be localized separately or in conjunction with the diaphragm.

10 The localized data are then passed to the tracking processor 300 and a model is generated which relates the position of the target as a function of the position of the diaphragm. The model is then passed to the treatment controller 460.

During subsequent treatment, the position of the diaphragm is monitored using reference marker localizer 160'. This can be performed using navigator scans which automatically detect the position of the diaphragm. More specifically, during treatment, the MRI apparatus generates navigator scan data for the navigator points localized during the preparation phase. These points are automatically identified by the reference marker localizer 160' using a navigator processor. Here, the localizer includes a navigator processor 162'. Accordingly, although it may be desirable, it is not necessary to image the target tissue 130 during the treatment phase.

20 The treatment controller then, having received the motion model parameters from the tracking processor and the navigator data from the reference marker localizer, controls the interventional device 400 as desired. In the embodiment shown, a focused ultrasound ablator 400' is controlled to treat the tumor 130 while it moves during normal subject movement, such as breathing.

The following examples provide additional explanation as to the operation of an embodiment of the invention. In a preparation phase a subject specific motion model is measured. For this purpose a time series of images (e.g. low resolution images) is measured during free respiration. Selected points of the diaphragm or other reference anatomical structures (e.g chest wall, or other abdominal or thoracic structures) are measured using navigators and stored in a vector $S(t)$. In a simple version, the navigators

are one-dimensional MR sub-experiments. The vector $S(t)$ contains the position of the corresponding structures as a function of time.

The MR images are then be registered according to a chosen motion model. For example, the model may be a 3D rigid body motion model or an affine transform which takes into account translation, rotation, scaling, and shear parameters. The corresponding model parameters are stored in a matrix A , which reflects the temporal changes of the corresponding parameters.

Using an appropriate mathematical transform, for example principal component analysis, a matrix B is determined which maps the navigator data $S(t)$ onto a model parameter $A'(t)$ in the sense of a statistical average where $A'(t) = B * S(t)$. This model provides for deriving the actual motion state of the target region as a function of time based on the navigator data.

By way of a more specific example, in a short free-breathing calibration scan, a time series of low-resolution "single-shot" 3D datasets are acquired depicting the respiratory motion of the target tissue. A motion registration algorithm at the localizer determines a set of model parameters for each 3D dataset reflecting the current respiratory motion state of the target. Subsequently, the tracking processor performs a statistical data analysis, for example based on a principal component analysis (PCA), to find the correspondence between the model parameters and the navigators. Consequently, at any time during the successional high-resolution coronary MRA scan an estimated motion state can be predicted from the currently measured navigator displacements, which is then used for prospective motion correction during the immediately following data acquisition step.

The motion considered can be described by a time-variant linear transformation $A(t)$ and an additional translation $d(t)$, which transforms each initial spatial point position $r = [x, y, z]^T$ to a new position $R(r, t)$

$$r \quad R(r,t) = A(t)r + d(t) \quad (1)$$

with
and

$$A(t) = \begin{bmatrix} 1 + a_{xx} & a_{xy} & a_{xz} \\ a_{yx} & 1 + a_{yy} & a_{yz} \\ a_{zx} & a_{zy} & 1 + a_{zz} \end{bmatrix}$$

$$d(t) = \begin{bmatrix} d_x \\ d_y \\ d_z \end{bmatrix}$$

(2)

The matrix $A(t)$ represents a general 3D linear transformation, which can be interpreted as the combination of rotations, scale, and shear transformations. The combination of the linear transformation and a translation is an affine transformation. The entries of matrix A and vector d are given as a function of the employed navigators, which are represented by a vector $s(t)$ containing the current displacements obtained by the navigators. The relation between the model parameters and the navigators can be adapted to the individual movement (e.g. breathing) pattern, which is described below.

For the preparatory scan, a multislice 2D fast gradient echo sequence (TFE-EPI) can be used to acquire a series of low-resolution 3D datasets depicting the respiration-induced motion of the target over several respiratory cycles.

Three pencil-beam navigators can be applied prior to the imaging block to characterize the current motion state. The navigators can be placed on the dome of the diaphragm in SI, on the anterior chest wall in AP, and on the right margin of the chest cavity in RL orientation. But, in principle, other navigator configurations may be possible, as long as the monitored tissue structure correlates well with the respiration-induced motion of the target.

After the scan, the 3D datasets are used to register 3D translational or 3D affine motion of the target with respect to an automatically selected reference dataset representing, for example, end-expiration. A manually defined 3D mask can be used to roughly suppress signal originating from tissue surrounding the target which may otherwise affect the accuracy of the motion registration of the target. A model-based registration algorithm on the basis of a global cross correlation measure and a Gauss-Newton optimization is used for motion registration. The output of the registration procedure is a series of parameter vectors $a(t)$, each representing the detected m model parameters of one single 3D dataset acquired at time t . In case of the 3D translation model the model parameter vector $a(t) = [d_x, d_y, d_z]^T$ contains three translation components ($m = 3$) and in case of the affine transformation $a(t) = [a_{xx} \dots a_{zz}, d_x, d_y, d_z]^T$ contains nine parameters a_{ij} , of the linear transformation and additional three translation components d_i ($m = 12$ parameters in total).

The relation between the m model parameters combined in $a(t)$ and the n navigator signals $s(t) = [s_{SI}, s_{AP}, s_{RL}, \dots]^T$ is then found which is represented by the time-invariant

coefficient matrix B:

$$a(t) = B s(t).$$

Thus, each model parameter is expressed as a linear combination of the current n navigator signals. The coefficient matrix B can be determined from the registration results $a(t)$ and the measured navigator displacements $s(t)$ by means of a statistical multivariate analysis similar to a multiple regression method. One potential problem can be potential multicollinearities, which occur if there are near-constant linear functions of two or more of the variables resulting in unstable or misleading solutions. Accordingly, in one embodiment, a principal component analysis (PCA) is used for data analysis.

The PCA is a statistical multivariate method commonly used to reduce the dimensionality of a given set of variables by transforming the original variables, which are the model parameters and the navigator signals here, to a set of new variables, namely, the principal components (PCs). The PCs are linear-independent and orthogonal in parameter space. Only a few of the strongest PCs suffice to cover the vast majority of system variability. The relation between model parameters and navigators is derived from these few strongest PCs.

The procedure for the data analysis is as follows: The model parameters $a(t)$ and the navigators $s(t)$ are combined to a new vector of $M = n + m$ variables $p(t) = [a_{xx} \dots a_{zz}, d_x, d_y, d_z, S_{SI}, S_{AP}, S_{RL}, \dots]^T$. The centered variable vectors

$$\tilde{p}(t) = p(t) - \bar{p}$$

20

with the mean parameter vector

$$\bar{p} = \frac{1}{N} \sum_{k=1}^N p(t_k)$$

representing the mean motion state and the number of sample points N (cardiac cycles covered by the calibration scan). The covariances between the elements of the centered variable vectors are given by the empirical covariance matrix

25

$$C = \tilde{P} \tilde{P}^T$$

where the matrix

$$\tilde{P} = [\tilde{p}(t_1), \tilde{p}(t_2) \dots \tilde{p}(t_N)]$$

contains the centered vectors of variables

$$\tilde{p}(t)$$

at all sample time points t of the complete calibration scan. Next, the eigenvalues $\lambda_1, \lambda_2, \dots, \lambda_M$ and the corresponding eigenvectors q_1, q_2, \dots, q_M of the covariance matrix C are calculated, which are the PCs or the major modes of variation of the system. An approximation of each possible motion state can be expressed as a weighted sum of the first μ eigenvectors

$$p' = \bar{p} + Qw$$

with matrix $Q = [q_1, q_2, \dots, q_\mu]$ consisting of the first μ eigenvectors. w is a vector of weight factors, representing a new set of variables in the coordinate system of the PCs, which is of minor importance in this context and which will be eliminated in the next step. The above equation for p' means a reduction of the system dimensionality from initially $M = 15$ parameters (12 affine model parameters + 3 navigators) to typically $\mu = 3$ or less parameters. The number of eigenvectors or PCs is determined during the phase of selecting the optimal combination of navigators described below. The system of equations given for p' can be split into two separate ones

$$\begin{aligned} a' &= Q_a w \\ s' &= Q_s w \end{aligned}$$

with $p' = [a', s']^T$ and where Q_a contains the top m rows and Q_s the bottom n rows of Q with the number of model parameters m and the number of navigators n . The constant average variable vector \bar{p} can be omitted here, since we are only interested in the variation of the system. The elimination of w yields

$$a' = B s \quad \text{with} \quad B = Q_a Q_s^{-1}$$

B is the desired coefficient matrix to be used for calculation of the estimated model parameters $a'(t)$ from the current navigator signals $s(t)$ required for motion correction during the subsequent scan. After the calibration procedure, the coefficient matrix B is provided to the treatment controller to be available for the subsequent treatment scan.

After the preparation procedure, the position of the target can be predicted with a neglectable latency (e.g. 10-30 ms) using navigators acquired in real-time. This information can be used to support the intervention either performed manually by the physician using appropriate display or overlays tools or by controlling interventional tools automatically by feeding back the position information to the treatment controller.

Accordingly, using an MR integrated focused ultra-sound (US) array tumor ablation can be performed, for example, in the kidney region. A respiratory motion model for the tumor region is established using an MR imaging protocol, which is correlated to, for example, the right hemi-diaphragm position. During therapy inside the MR-scanner, navigators are applied (on a roughly one second time base) to probe the current respiratory state. Based on the navigator data, the motion state of the tumor region can be derived and predicted in real-time. This information steers the US-ablation array to treat the tumor. The information can also be used to guide robotic arm biopsy procedures, other minimally invasive surgical procedures, and the like.

This concept can be extended using not only one-dimensional navigators but to multi-dimensional navigators as well.

The invention has been described with reference to the preferred embodiment. Obviously, modifications and alterations will occur to others upon reading and understanding the preceding description. It is intended that the invention be construed as including all such modifications and alterations insofar as they come within the scope of the appended claims or the equivalents thereof.

CLAIMS

What is claimed is:

1. A target treatment apparatus for treating a target region (130) within a subject (140), the apparatus comprising:
 - 5 an MRI apparatus (100) for generating MR images during an MR scan of the subject disposed within an examination region (110);
an MRI localizer (150) for receiving the image data from the MRI apparatus wherein the target (130) is localized;
 - a reference marker localizer (160, 160') for non-invasively receiving reference data
10 from a plurality of reference points disposed in proximity to the target wherein the reference points are localized; and
 - a tracking processor (300) for receiving localized data from the MRI localizer wherein a relationship between the reference markers and the target region is generated.
- 15 2. A target treatment apparatus as set forth in claim 1 further comprising:
a treatment controller (460) for receiving: (i) the relationship between the reference markers and the target region from the tracking processor; and (ii) reference marker data from the reference marker localizer during a target treatment session, wherein an interventional tool (400, 400') is controlled to treat the target (130).
20
3. A target treatment apparatus as set forth in claim 2 wherein the plurality of reference points are defined by a plurality of external markers disposed on the subject and the reference marker localizer comprises a plurality of video cameras (161₁, 161₂) for detecting the external markers.
25
4. A target treatment apparatus as set forth in claim 2 wherein the plurality of reference points are defined by a plurality of points on the diaphragm of the subject and the reference marker localizer comprises a navigator processor (162') for identifying the reference points from a navigator scan.
30
5. A target treatment apparatus as set forth in claim 4 wherein the interventional tool comprises a focused ultrasound ablator disposed within the examination region.

6. A method of treating a target region (130) within a subject (140), the method comprising:
generating magnetic resonance images of the subject disposed within an
5 examination region (110);
localizing the target region from the MR images;
non-invasively localizing a plurality of reference points disposed in proximity to
the target; and
generating a relationship between the reference markers and the target region.
10
7. A method as set forth in claim 6 further comprising:
localizing at least a sub-set of the reference points during a treatment session; and
controlling an interventional tool based on the localized reference points from the
treatment session which serve as input to the relationship between the reference markers
15 and the target region to estimate the location of the target.
8. A method as set forth in claim 6 wherein the plurality of reference points are
defined by a plurality of external markers disposed on the subject and the reference
markers are localized using a plurality of video cameras (161₁, 161₂).
20
9. A method as set forth in claim 6 wherein the plurality of reference points are
defined by a plurality of points on the diaphragm of the subject and the reference points are
localized using a navigator processor.
- 25 10. A method set forth in claim 7 wherein the interventional tool comprises a focused
ultrasound ablator.
11. An apparatus for treating a target region (130) within a subject (140), the apparatus
comprising:
30 means for generating magnetic resonance images of the subject disposed within an
examination region (110);
localizing means for localizing the target region from the MR images;

reference means for non-invasively localizing a plurality of reference points disposed in proximity to the target; and

modeling means for generating a relationship between the reference markers and the target region.

5

12. An apparatus as set forth in claim 11 further comprising:

means for localizing at least a sub-set of the reference points during a treatment session; and

10 interventional means for controlling an interventional tool based on the localized reference points from the treatment session which serve as input to the relationship between the reference markers and the target region to estimate the location of the target.

13. An apparatus as set forth in claim 11 wherein the plurality of reference points are defined by a plurality of external markers disposed on the subject and the reference
15 markers are localized using a plurality of video cameras (161₁, 161₂).

14. An apparatus as set forth in claim 11 wherein the plurality of reference points are defined by a plurality of points on the diaphragm of the subject and the reference points are localized using a navigator processor.

20

15. An apparatus as set forth in claim 12 wherein the interventional tool comprises a focused ultrasound ablator.

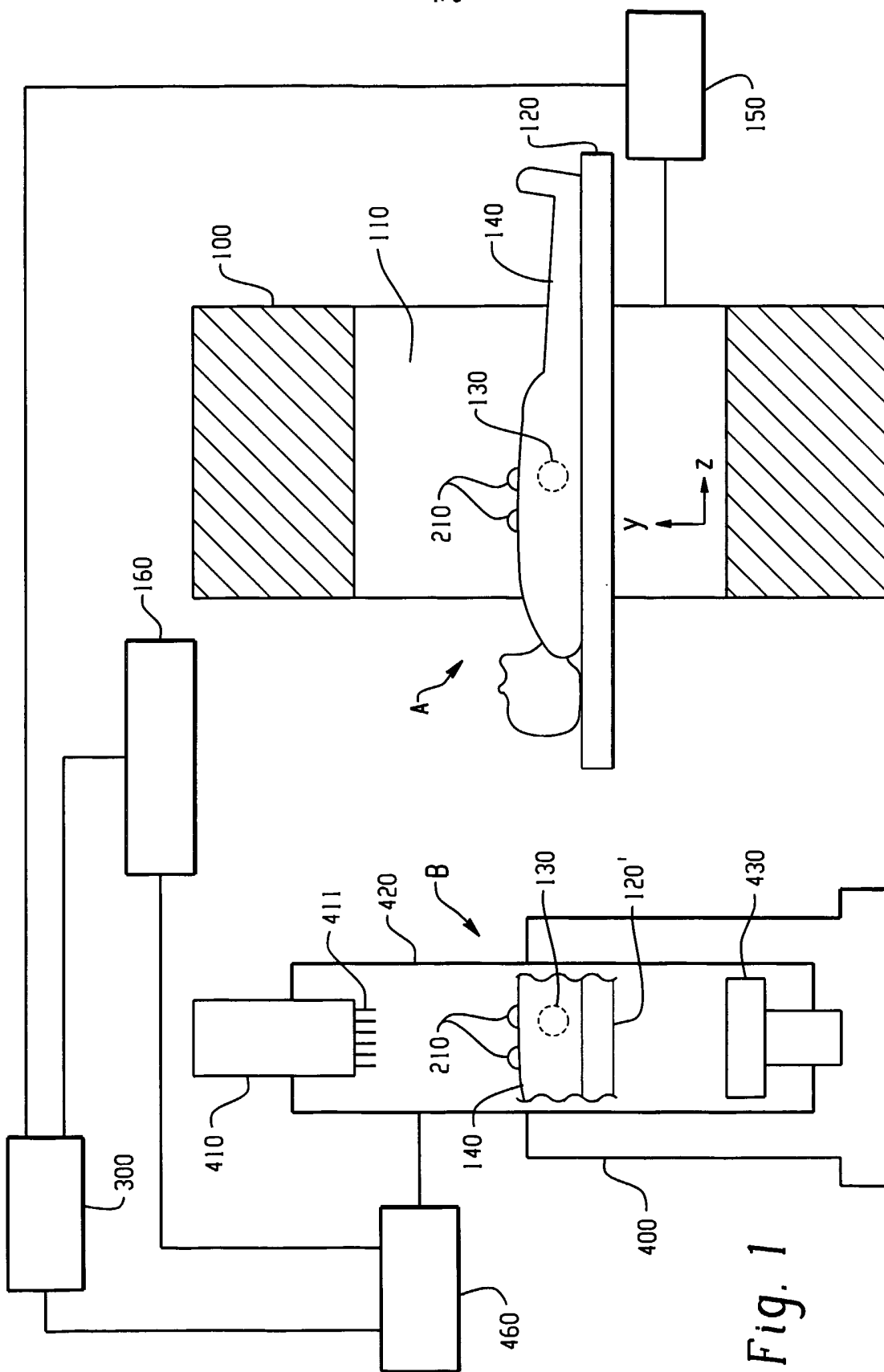

Fig. 1

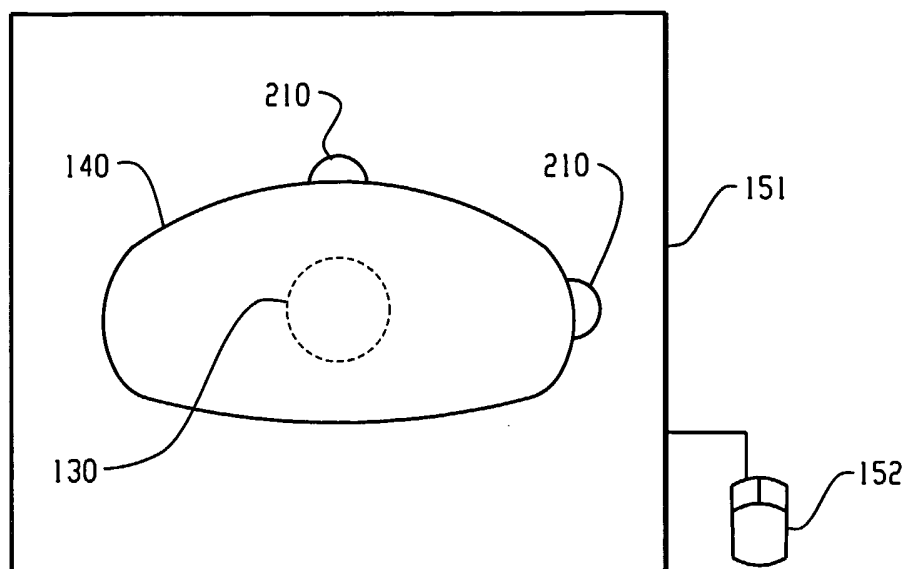

Fig. 2

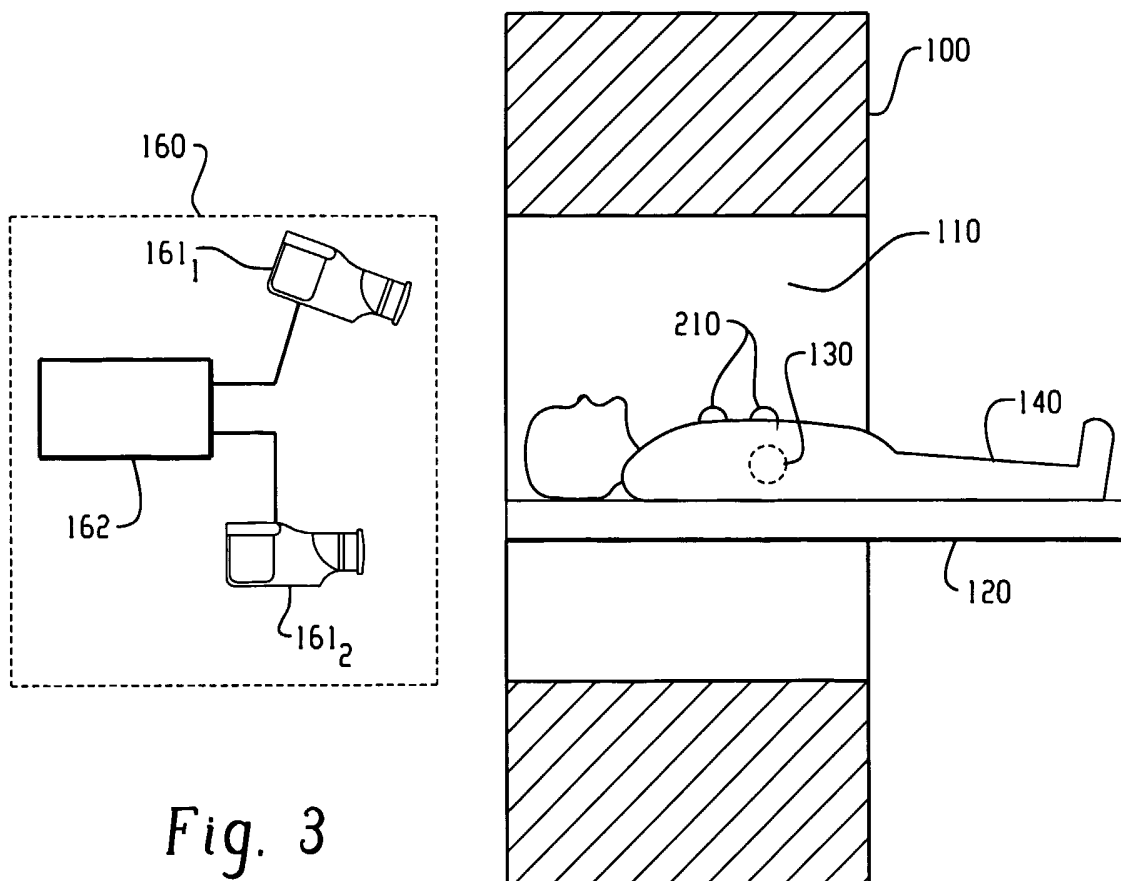

Fig. 3

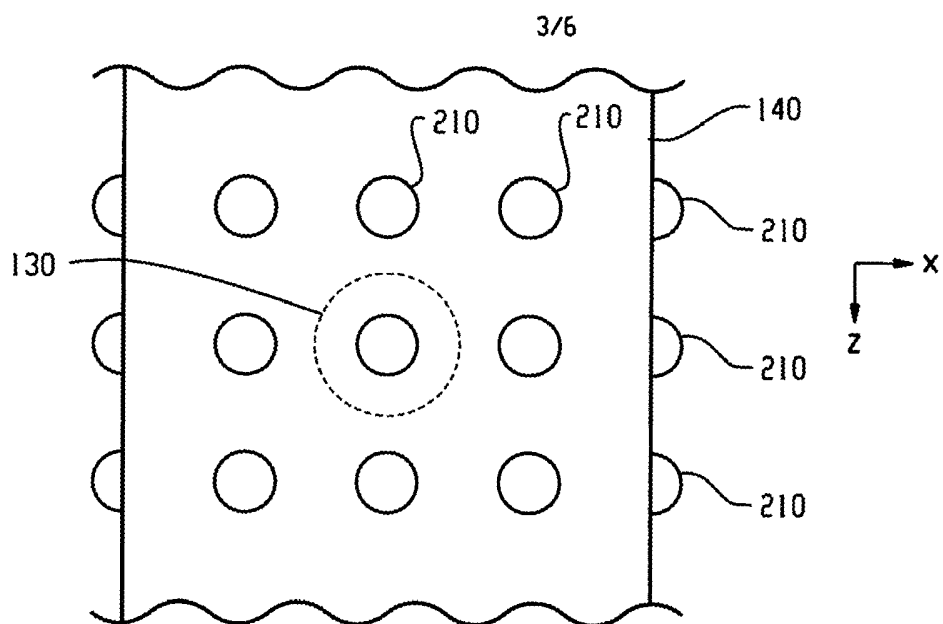

Fig. 4A

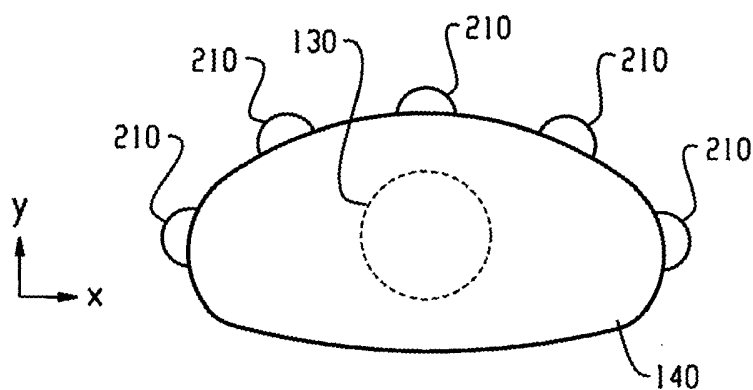

Fig. 4B

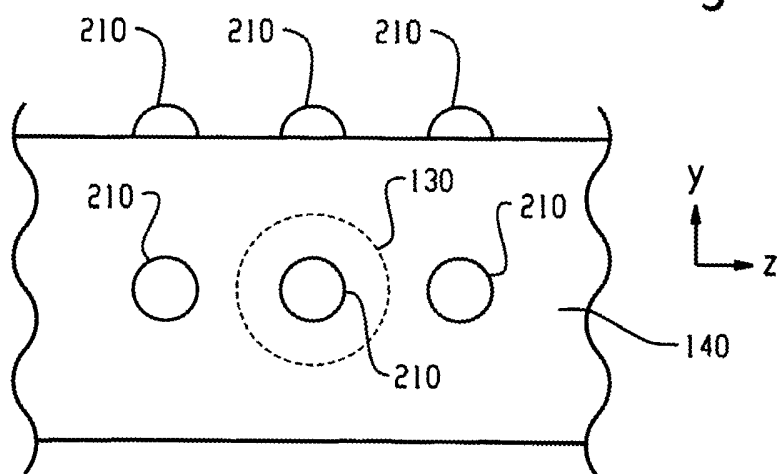

Fig. 4C

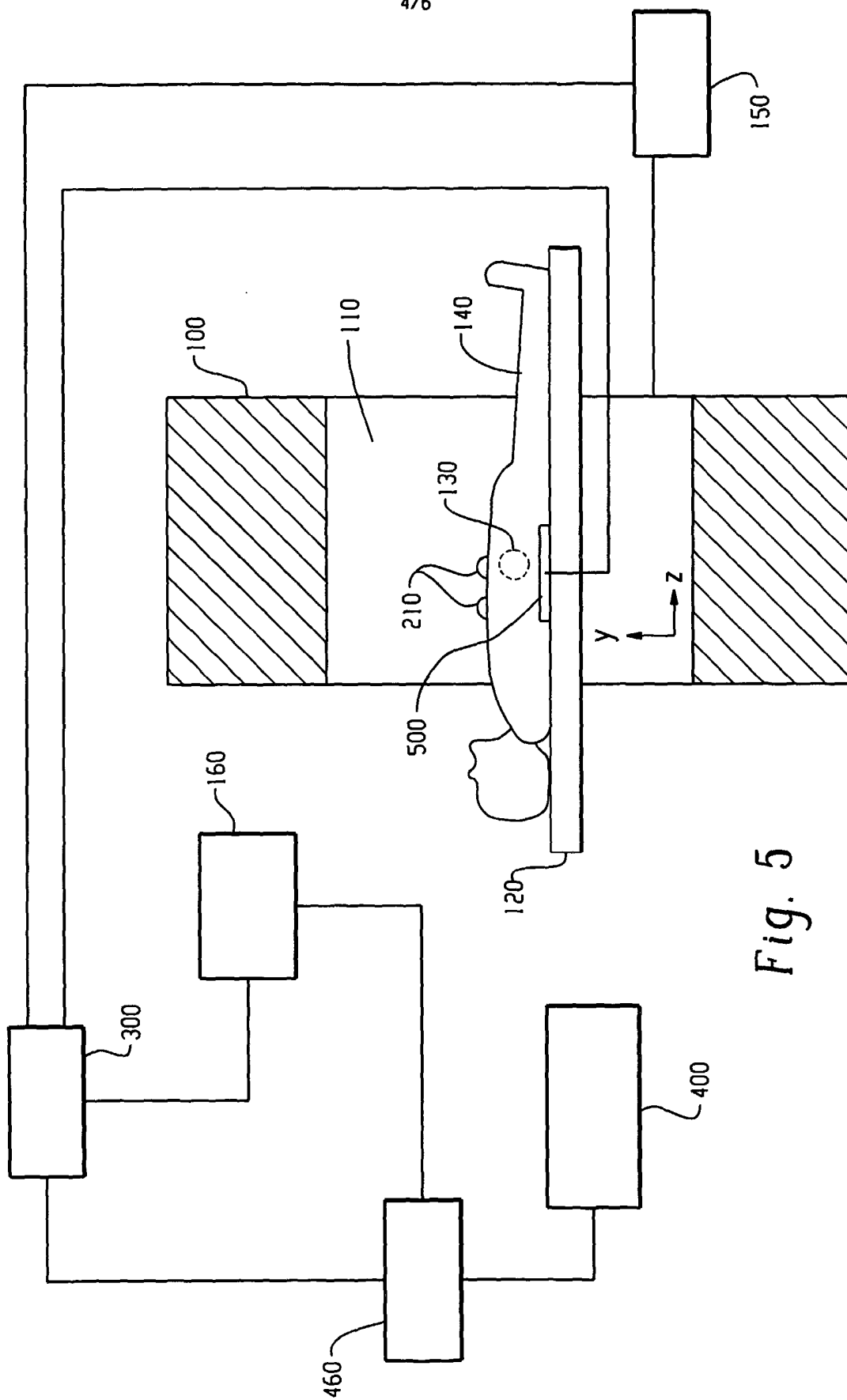

Fig. 5

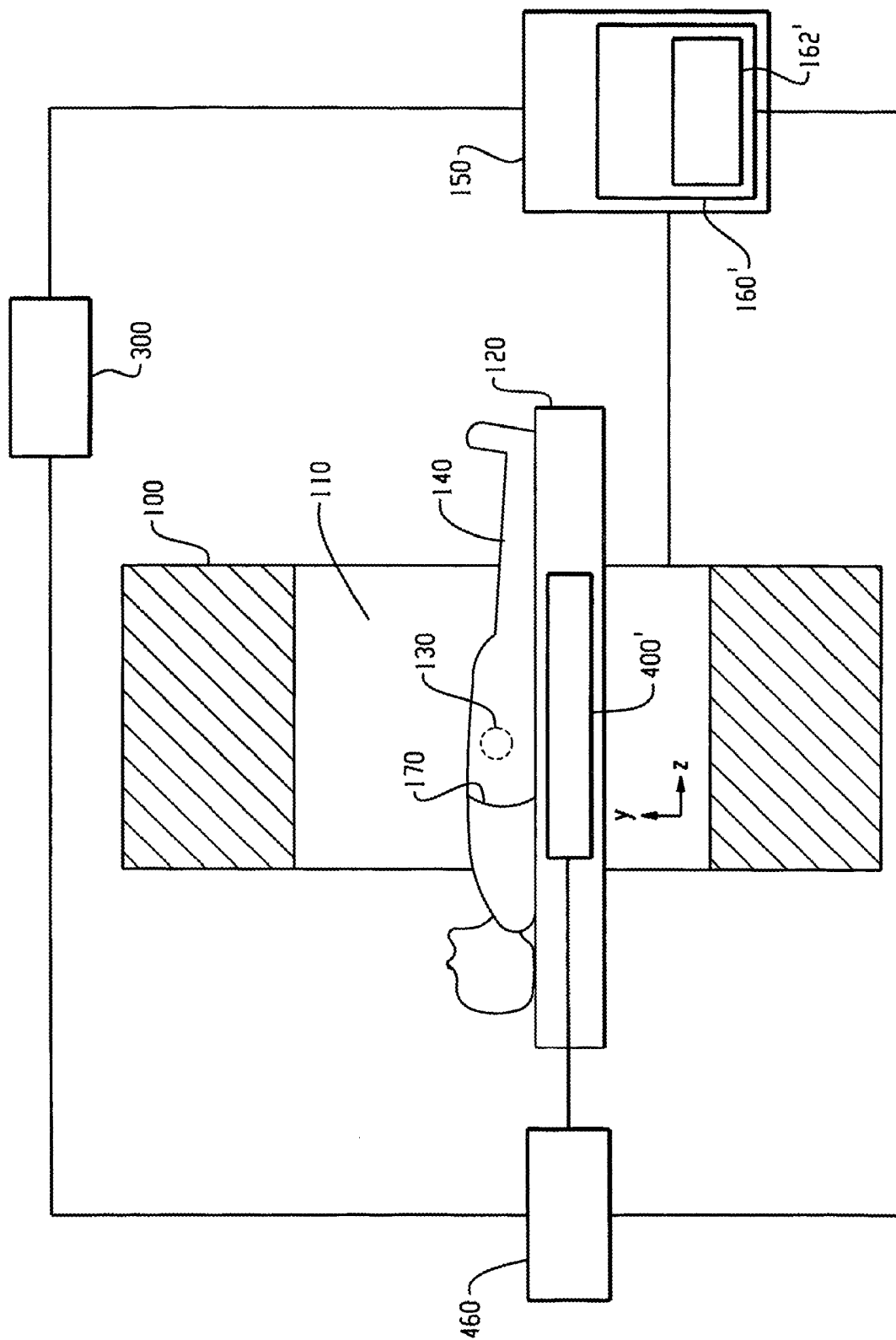

Fig. 6

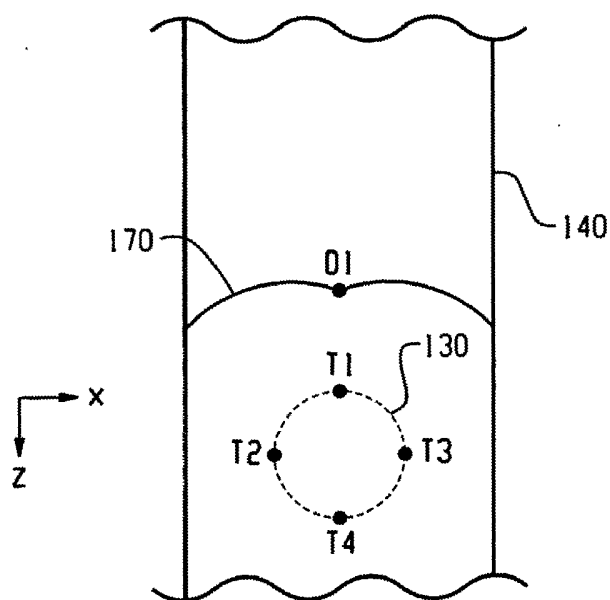

Fig. 7

INTERNATIONAL SEARCH REPORT

IB2004/051741

A. CLASSIFICATION OF SUBJECT MATTER
 IPC 7 A61N7/02 A61N5/10

According to International Patent Classification (IPC) or to both national classification and IPC

B. FIELDS SEARCHED

Minimum documentation searched (classification system followed by classification symbols)
 IPC 7 A61N A61B

Documentation searched other than minimum documentation to the extent that such documents are included in the fields searched

Electronic data base consulted during the international search (name of data base and, where practical, search terms used)

EPO-Internal

C. DOCUMENTS CONSIDERED TO BE RELEVANT

Category °	Citation of document, with indication, where appropriate, of the relevant passages	Relevant to claim No.
X	EP 1 319 368 A (TECMEDIC GMBH) 18 June 2003 (2003-06-18) paragraphs '0004! - '0006!; figures 1-5 -----	1-5, 11-15
A	US 6 501 981 B1 (SCHWEIKARD ACHIM ET AL) 31 December 2002 (2002-12-31) column 2, lines 34-67 column 3, line 66 - column 4, line 11 -----	1-5, 11-15
A	US 6 374 132 B1 (ACKER DAVID E ET AL) 16 April 2002 (2002-04-16) abstract column 22, lines 17-54 -----	1-5, 11-15
A	WO 99/27839 A (COSMAN ERIC R) 10 June 1999 (1999-06-10) abstract -----	1-5, 11-15

Further documents are listed in the continuation of box C.

Patent family members are listed in annex.

° Special categories of cited documents :

- *A* document defining the general state of the art which is not considered to be of particular relevance
- *E* earlier document but published on or after the international filing date
- *L* document which may throw doubts on priority claim(s) or which is cited to establish the publication date of another citation or other special reason (as specified)
- *O* document referring to an oral disclosure, use, exhibition or other means
- *P* document published prior to the international filing date but later than the priority date claimed

- *I* later document published after the international filing date or priority date and not in conflict with the application but cited to understand the principle or theory underlying the invention
- *X* document of particular relevance; the claimed invention cannot be considered novel or cannot be considered to involve an inventive step when the document is taken alone
- *Y* document of particular relevance; the claimed invention cannot be considered to involve an inventive step when the document is combined with one or more other such documents, such combination being obvious to a person skilled in the art.
- *&* document member of the same patent family

Date of the actual completion of the international search

29 November 2004

Date of mailing of the international search report

10/12/2004

Name and mailing address of the ISA

European Patent Office, P.B. 5818 Patentlaan 2
 NL - 2280 HV Rijswijk
 Tel. (+31-70) 340-2040, Tx. 31 651 epo nl,
 Fax: (+31-70) 340-3016

Authorized officer

Willig, H

INTERNATIONAL SEARCH REPORT

International application No.
PCT/IB2004/051741

Box II Observations where certain claims were found unsearchable (Continuation of item 2 of first sheet)

This International Search Report has not been established in respect of certain claims under Article 17(2)(a) for the following reasons:

1. Claims Nos.: 6-10
because they relate to subject matter not required to be searched by this Authority, namely:
Rule 39.1(iv) PCT - Method for treatment of the human or animal body by surgery and therapy
2. Claims Nos.:
because they relate to parts of the International Application that do not comply with the prescribed requirements to such an extent that no meaningful International Search can be carried out, specifically:
3. Claims Nos.:
because they are dependent claims and are not drafted in accordance with the second and third sentences of Rule 6.4(a).

Box III Observations where unity of invention is lacking (Continuation of item 3 of first sheet)

This International Searching Authority found multiple inventions in this international application, as follows:

1. As all required additional search fees were timely paid by the applicant, this International Search Report covers all searchable claims.
2. As all searchable claims could be searched without effort justifying an additional fee, this Authority did not invite payment of any additional fee.
3. As only some of the required additional search fees were timely paid by the applicant, this International Search Report covers only those claims for which fees were paid, specifically claims Nos.:
4. No required additional search fees were timely paid by the applicant. Consequently, this International Search Report is restricted to the invention first mentioned in the claims; it is covered by claims Nos.:

Remark on Protest

- The additional search fees were accompanied by the applicant's protest.
- No protest accompanied the payment of additional search fees.

INTERNATIONAL SEARCH REPORT

IB2004/051741

Patent document cited in search report		Publication date	Patent family member(s)	Publication date
EP 1319368	A	18-06-2003	DE 10161160 A1	18-06-2003
			EP 1319368 A2	18-06-2003

US 6501981	B1	31-12-2002	US 6144875 A	07-11-2000
			AU 9068801 A	22-03-2002
			WO 0219908 A1	14-03-2002
			US 2003125622 A1	03-07-2003
			AT 269035 T	15-07-2004
			AU 3882700 A	04-10-2000
			DE 60011607 D1	22-07-2004
			EP 1176919 A1	06-02-2002
			JP 2003523220 T	05-08-2003
			WO 0054689 A1	21-09-2000
			US 6778850 B1	17-08-2004

US 6374132	B1	16-04-2002	US 6128522 A	03-10-2000
			US 6516211 B1	04-02-2003
			US 6773408 B1	10-08-2004
			AU 8053598 A	11-12-1998
			CN 1257414 T	21-06-2000
			EP 0998217 A1	10-05-2000
			JP 2002505596 T	19-02-2002
			WO 9852465 A1	26-11-1998

WO 9927839	A	10-06-1999	US 6405072 B1	11-06-2002
			AU 1800999 A	16-06-1999
			CA 2320230 A1	10-06-1999
			EP 1041918 A2	11-10-2000
			US 2002065461 A1	30-05-2002
			WO 9927839 A2	10-06-1999
