

H. A. STONE.

Machines for Making Wooden Gutters.

No. 157,703.

Patented Dec. 15, 1874.

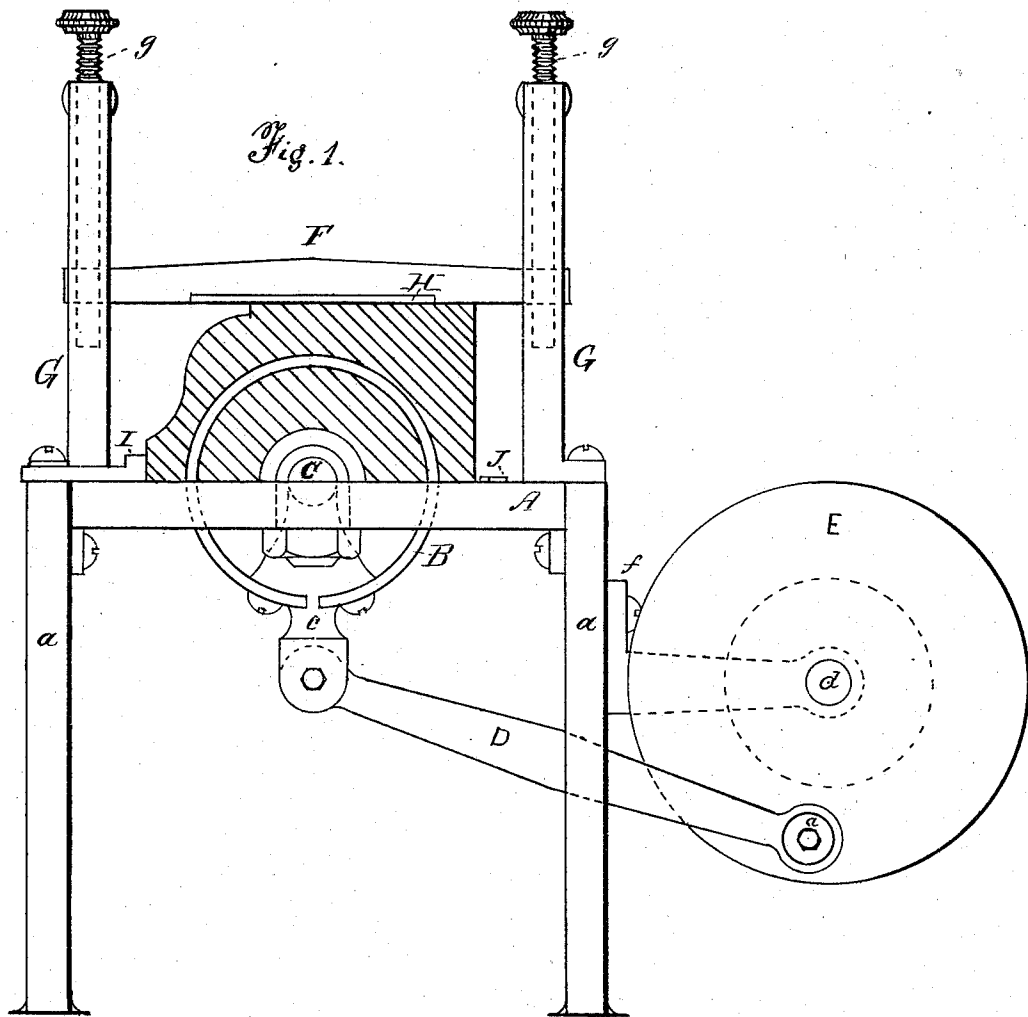

WITNESSES;
William H. Colby
Frank Stone

INVENTOR;
Henry A Stone
per Chas. H. Fowler
Atty.

H. A. STONE.

Machines for Making Wooden Gutters.

No. 157,703.

Patented Dec. 15, 1874.

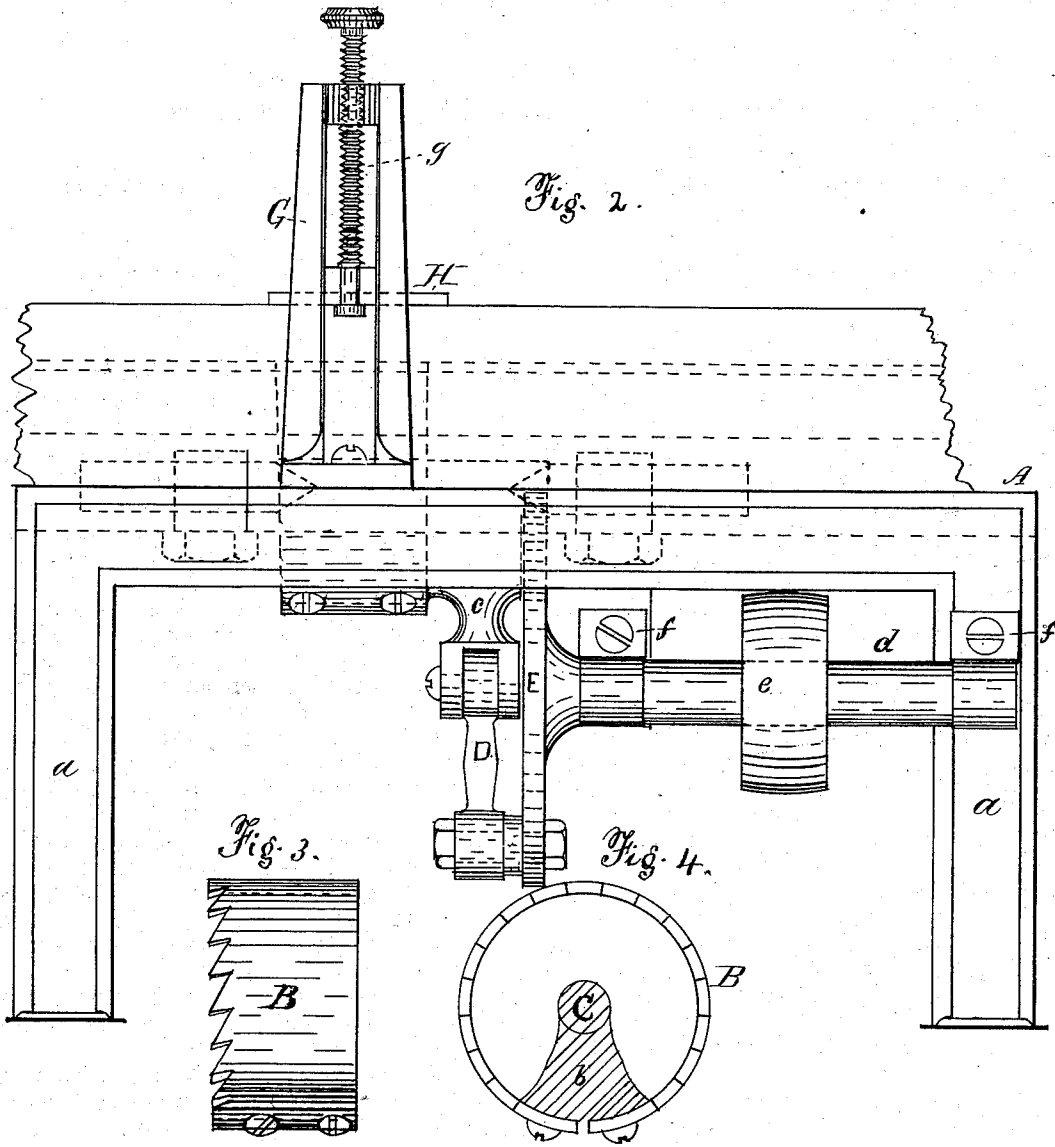

WITNESSES;
William H. Eddy,
Frank Stone,

INVENTOR;
Henry A. Stone
per Chas. H. Fowler,
Atty.

UNITED STATES PATENT OFFICE.

HENRY A. STONE, OF WORCESTER, MASSACHUSETTS.

IMPROVEMENT IN MACHINES FOR MAKING WOODEN GUTTERS.

Specification forming part of Letters Patent No. 157,703, dated December 15, 1874; application filed October 5, 1874.

To all whom it may concern:

Be it known that I, HENRY A. STONE, of Worcester, in the county of Worcester and State of Massachusetts, have invented certain new and useful Improvements in Machines for Making Wooden Gutters; and I do hereby declare that the following is a full, clear, and exact description thereof, which will enable others skilled in the art to which it pertains to make and use the same, reference being had to the accompanying drawings, and the letters of reference marked thereon, which form a part of this specification.

Figure 1 of the drawing represents an end view of my invention; Fig. 2, a side elevation of the same; Fig. 3, a side view of the hollow cylindrical saw detached from the machine; Fig. 4, an end view of the same, showing the cutter-bar attached.

Similar letters of reference indicate corresponding parts.

My invention relates to improvements in that class of machines employed in making wooden gutters, in which a cylindrical saw is used to cut out the required cavity; and my invention consists in the arrangement and combination of parts, as will be hereinafter more fully described.

A in the drawing represents a table or platform, made of metal or other suitable material, and supported on standards *a*. The saw B, which is made in the form of a hollow cylinder, is attached by bolts or rivets to a cutter-bar, *b*, said bar being connected to a stationary shaft, C, upon which shaft the bar is free to work. Projecting from one side of the bar

b, and at right angles thereto, is a small arm, *c*, to which is swiveled one end of the shaft D, the other end being connected eccentrically to the wheel E. This wheel E is connected to the driving-shaft *d* and pulley *e*, the shaft and pulley working in bearings formed in the projecting arms *f f*. Secured upon either side of the table A are slotted standards G, in which the ends of the bar F work and are guided, said bar being provided with a pressure-plate, H. This bar F and pressure-plate H are capable of being adjusted to the thickness of the gutter by the regulating-screws *g g*. Upon one side of the table A is an adjustable gage, I, and upon the other side, opposite said gage, a spring or yielding bar, J. This spring or yielding bar J presses against the side of the gutter, which, in connection with the gage I, prevents the possibility of any side or lateral motion of the gutter as it passes over the table, and the pressure-plate H, keeping the gutter down upon the table or bed, holds it in proper position in relation to the saw, while a semi-rotary motion is imparted thereto.

Having thus described my invention, what I claim as new, and desire to secure by Letters Patent, is—

In combination with the hollow cylindrical semi-rotary saw B, the pressure-plate H, working in slotted standards G G, adjustable gage I, and spring or yielding bar J, substantially as and for the purpose set forth.

HENRY A. STONE.

Witnesses:

WILLIAM H. EDDY,
FRANK STONE.