

(12) UK Patent Application (19) GB (11) 2 1 1 2 6 5 4 A

(21) Application No 8137785

(22) Date of filing
15 Dec 1981

(43) Application published
27 Jul 1983

(51) INT CL³ A63F 7/30

(52) Domestic classification
A6S 26D 26E5X 32B
32X
A6H 10X19

(56) Documents cited

GB 1428059

GB 1068859

GB 0627772

GB 0615497

GB 0362644

GB 0332881

GB 0317136

GB 0307783

(58) Field of search

A6H

A6S

(71) Applicant

Michael Wichinsky
2607 South Highland
Drive
Las Vegas
Nevada 89109
United States of
America

LeRoy Gutknecht
2607 South Highland
Drive
Las Vegas
Nevada 89109
United States of
America

(72) Inventors

Michael Wichinsky
LeRoy Gutknecht

(74) Agent and/or Address for
Service

Withers and Rogers
4 Dyer's Buildings
Holborn
London EC1N 2JT

(54) Game apparatus for projec-
tion of coins and the like

(57) The apparatus has a cabinet (2) defining a playing area, a plurality of coin slots (10), and a rotatable, ribbed, drum beneath the slots for projecting an accepted coin within the playing area towards an upper portion (3) thereof where there are a plurality of baskets (6, 7) containing sensors actuated by a coin passing through a basket to secure a predetermined award. The basket (7) may be movable. In a lower portion of the playing area are two shelves (8) onto which projected coins may fall, the shelves being traversed by pusher bars (9) which push collected coins towards the edge of the respective shelf.

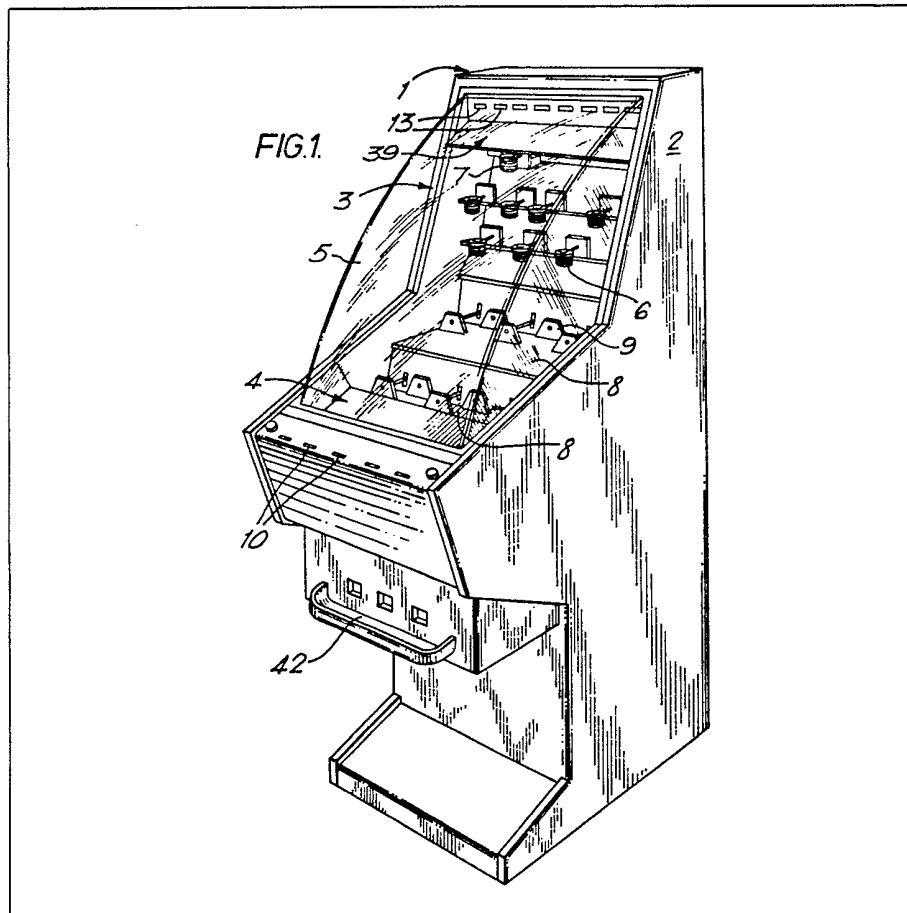

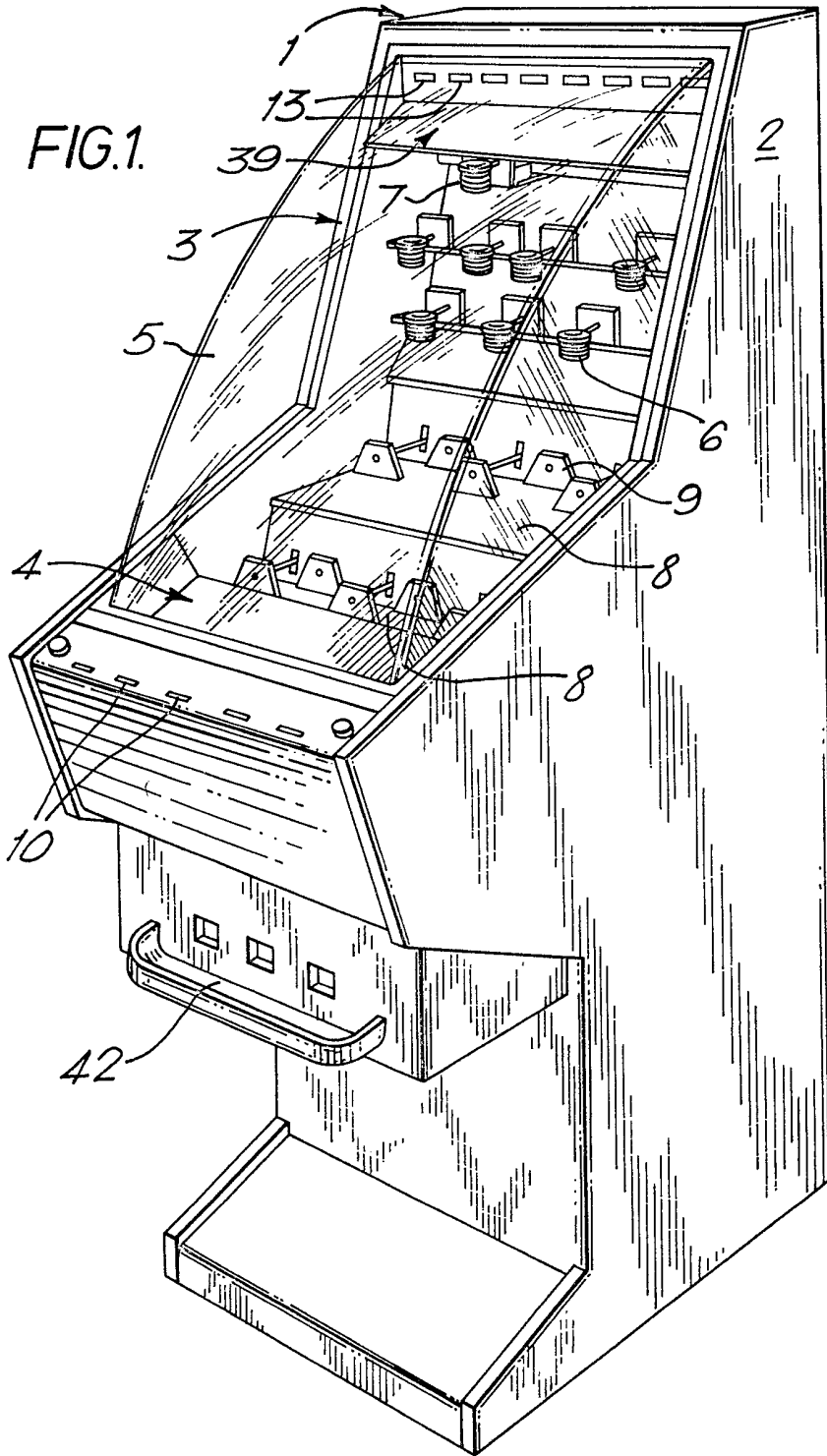

FIG. 1.

FIG. 2.

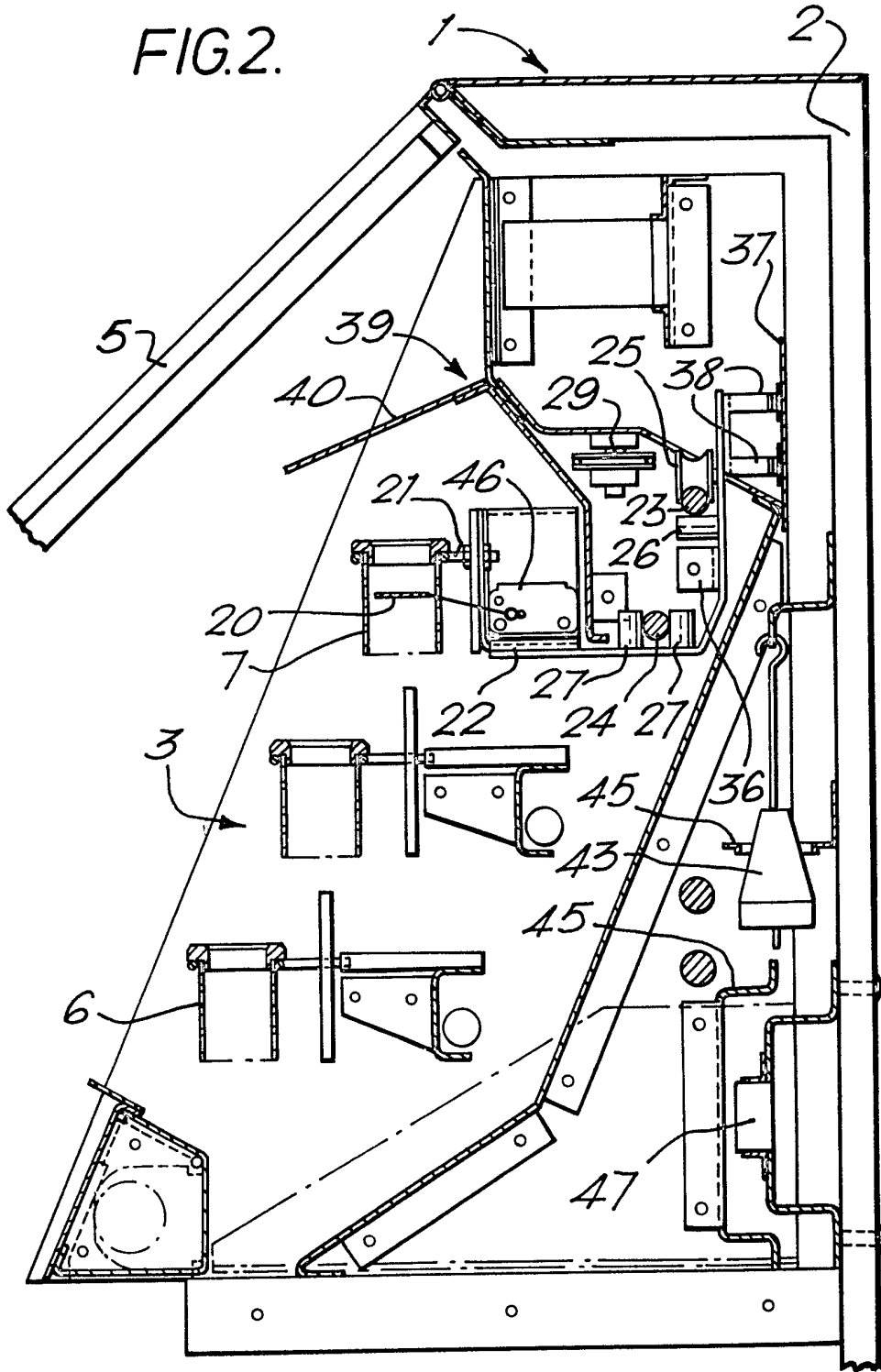
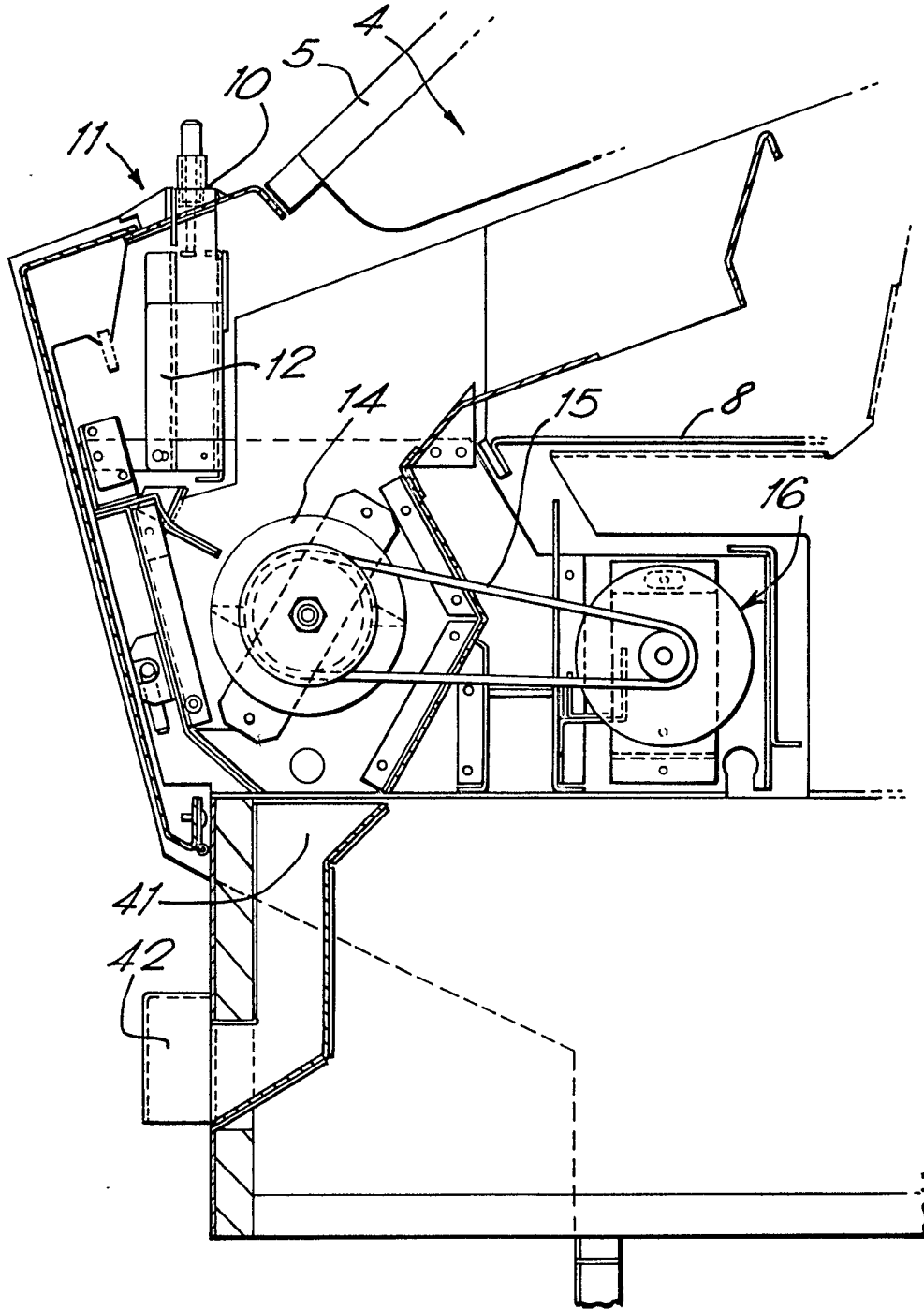

FIG.3.



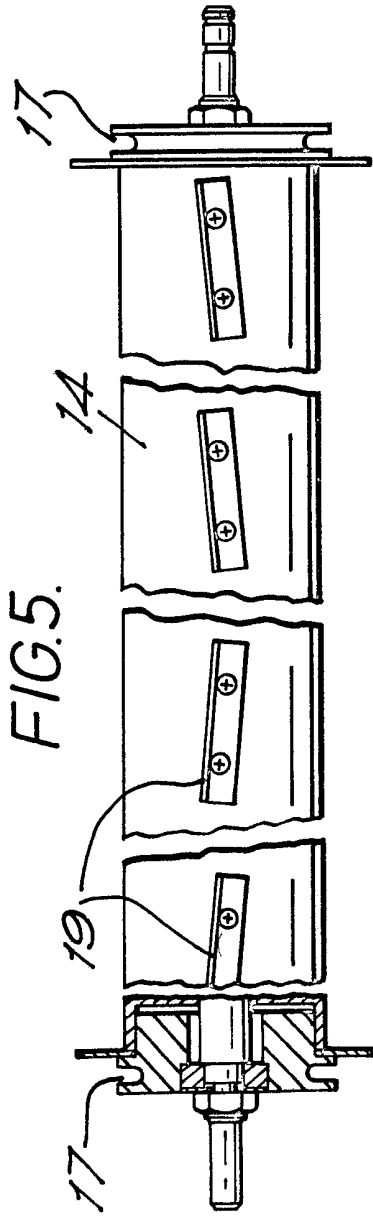

FIG. 5.

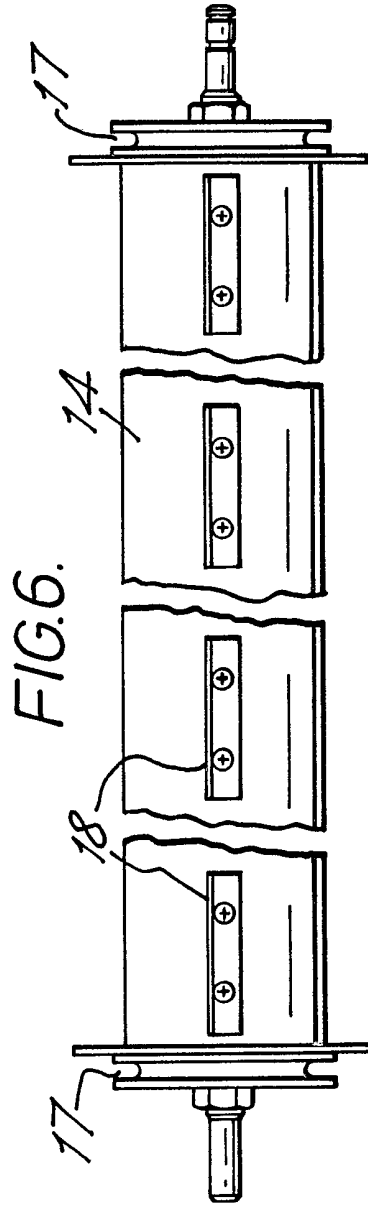

FIG. 6.

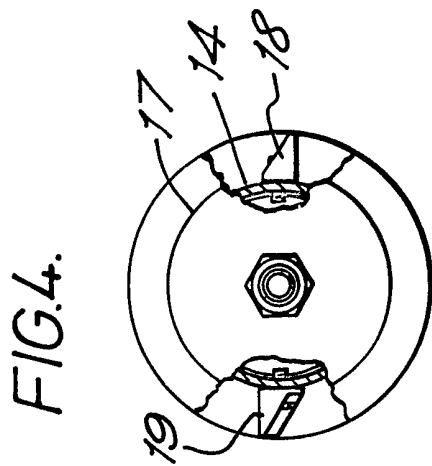
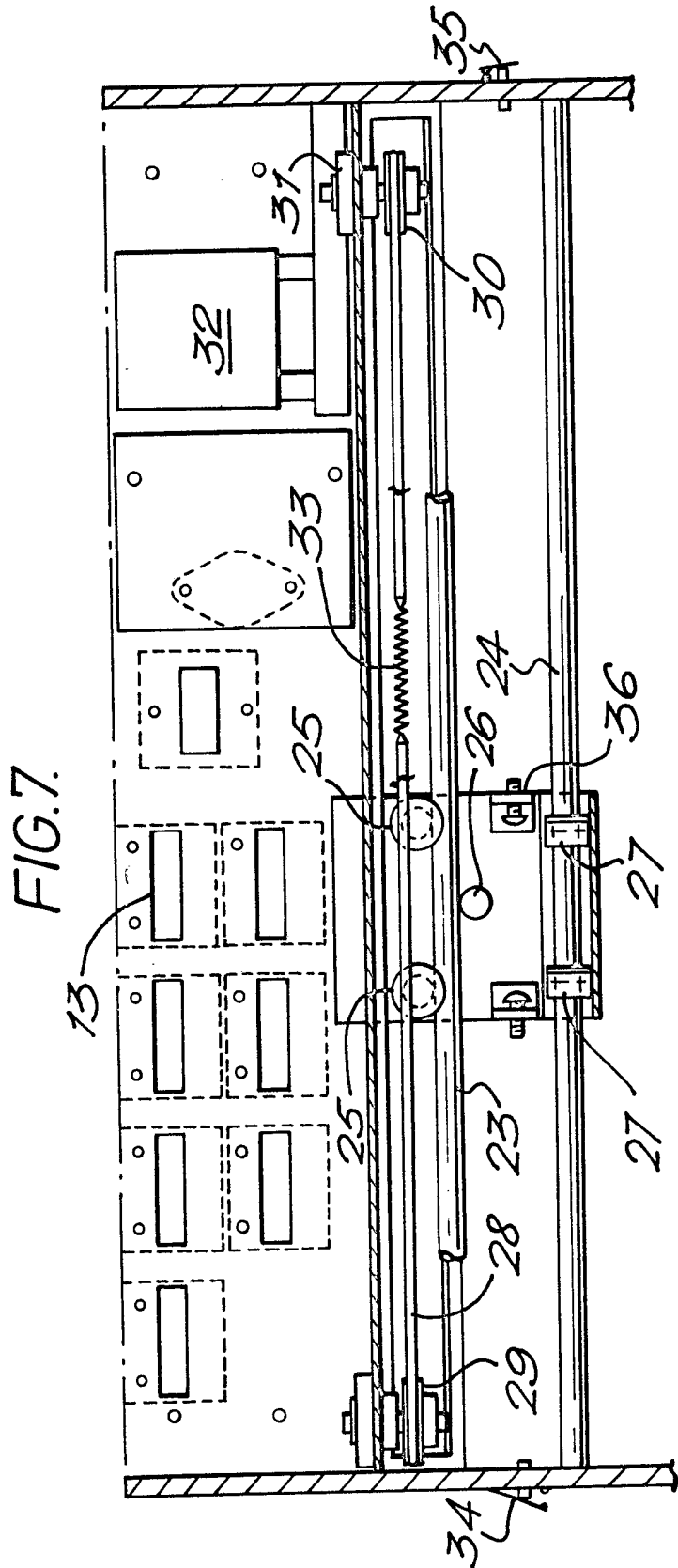

FIG. 4.



SPECIFICATION

Game apparatus

5 This invention relates to an improved game apparatus. Amusement apparatus in which coins are dropped onto a shelf traversed by pusher bars is well known. In such an arrangement the coins build up on the shelf
 10 until the constant movement of the pusher bars causes coins to fall off a forward edge of the shelf as an award.

An object of the present invention is to provide an improved game apparatus including skill and which, in the preferred embodiment, is combined with such known amusement apparatus.

According to the present invention a game apparatus comprises a cabinet defining a playing area, means for receiving a playing piece such as a coin, token or the like, means for projecting an accepted playing piece within the playing area, and a sensor, disposed within the playing area, which is triggered by
 25 a projected playing piece, the sensor, on actuation by such contact, causing the apparatus to register a predetermined award.

Preferably, the sensor is movable and a plurality of fixed sensors are also disposed within the playing area.

In the preferred embodiment of a game apparatus comprises a cabinet defining a playing area, means for receiving a playing piece such as a coin, token or the like, means for projecting an accepted playing piece within the playing area, a plurality of shrouded sensors in an upper portion of the playing area, at least one shelf onto which playing pieces may fall after projection, in a lower portion of
 40 the playing area, pusher means for traversing the at least one shelf surface so as to push collected playing pieces towards an edge of the shelf, and means for moving at least one of said shrouded sensors within the playing area, the sensors being actuated by contact with a playing piece and being operative to cause the apparatus to register a predetermined award.

The invention will now be described by way of example with reference to the accompanying drawings which illustrate a preferred embodiment of the game apparatus of the present invention in which:

Figure 1 is a front elevation;

55 *Figure 2* is a side elevation of the upper portion of the apparatus;

Figure 3 is a side elevation of the lower portion of the apparatus;

Figure 4 is an end view of the drum in *Fig. 3* partially broken away for clarity;

Figure 5 is a view on A-A in *Fig. 4*;

Figure 6 is a view on B-B in *Fig. 4*; and

Figure 7 is a front view in the direction of arrow C in *Fig. 2* partially broken away.

65 In the drawings a game apparatus 1 comprises a cabinet 2 defining an upper portion 3 and a lower portion 4. The upper portion 3 has a transparent front panel 5 and includes a plurality of fixed baskets 6 projecting from the

70 rear of the cabinet and a movable basket 7. The lower portion 4 includes two horizontally disposed shelves 8 staggered vertically one above the other and each including a plurality of pusher bars 9 which, in use, are continuously moved forwardly and rearwardly across the surface of the respective shelf 8 by crank means (not shown) in known manner.

75 The game apparatus 1 is coin-operated and the cabinet 2 includes a plurality of coin slots 10 disposed along a front edge 11. Each coin slot 10 includes a conventional mechanical coin detector 12 which detects incorrect coins by size, metal content or weight. An accepted coin triggers a switch to record the number of
 80 coins inserted in a particular coin slot on a respective meter housed at the top of the machine and generally indicated 13 in *Figs. 2* and 7.

Located below the coin slots 10 is a rotatable flipper drum 14 which is driven through belts 15 by two 1550 RPM motor 16. The drum 14 is driven by two motors in order to provide a balanced drive such that the belts run with less tension: in addition the second
 85 motor serves as a back-up drive should one of the two drive belts ever break. The drum speed is preferably within 5% of 660 RPM in order to provide the desired results. The ends of the drum 14 each include a groove 17
 90 which receives the respective belt 15 and the surface is provided with two sets of protruding, diametrically opposed, bars 18 and 19. The set of bars 18 are aligned with one another whereas the set of bars 19 are angled at about 5° as shown in *Fig. 4*. In use accepted coins from the coin slots 10 fall onto the rotating drum 14 and are projected by the protruding bars 18 and 19 into the playing area towards the baskets 6 and 7. The separation of the bars and the angles at which they are set provide random distribution of the projected coins within the playing area of the cabinet 2. Each of the baskets 6 and 7 includes a switch 20 which will be actuated
 95 by a coin passing through the basket so that an appropriate reward may be awarded as explained hereinafter.

In order to include an additional element of skill into the game the basket 7 is supported, by means of an arm 21, upon a frame 22 which is movable across the rear of the cabinet 2. The frame 22 is generally U-shaped in cross-section and rides upon two rails 23, 24 extending between the opposed sides of the cabinet 2. The rail 23 receives two spaced upper rollers 25 and a lower stabilising roller bearing 26, the rail 24 merely serves as a guide and is engaged by two roller centrally disposed bearings 27.
 100
 105
 110
 115

The basket 7 and frame 22 are driven by

130

means of a steel cable 28 which is tensioned between a free pulley 29 and a pulley 30 affixed to the rotor 31 of a reversible motor 32 by a spring 33. The drive connection
5 between the cable 28 and the frame 22 is by means of a pin (not shown) extending from the frame into engagement with the spring 33.

At each end of the transverse run of the
10 basket 7 there is a switch 34, 35 one of which is normally open and the other of which is normally closed. These switches are actuated alternately by a respective, adjustable screw which project laterally from mount-
15 ings 36 on the frame 22. Actuation of the switches 34, 35 operates a latch relay to reverse the motor 32 at the end of a traverse.

Fig. 2 shows clearly the switch arrangement which consists of the low torque switch plate
20 20 within the basket 7 connected to the switch unit 36 mounted within the frame 22. In order to maintain electrical contact throughout the movement of the basket 7 a fixed printed circuit board contact 37 is having two
25 parallel tracks provided at the rear of the frame 22 and this is traversed by two wiper contacts 38. The basket 7 moves across the cabinet at a speed of about 4 inches per second.

The shape of the hood 39 disposed above the basket 7 and its length is specially designed so that only coins which are projected by the drum 14 at the correct trajectory can pass into the basket 7. The forward portion
30 40 of the hood 39 is transparent.

In use the drum 14 rotates and the pusher bars 9 move across the surfaces of the shelves 8. The coins which are accepted by the detector are projected towards the baskets
40 6 and 7 and then drop down onto the shelves 8. If a coin passes through a basket as it drops the respective switch 20 is actuated which causes an appropriate award to be paid out from a coin counter in known manner. If a
45 coin fails to be projected then the coin is returned via chute 41 to the collection tray 42 for further use.

As the game continues the coins build up on the shelves and, intermittently, the pusher
50 bars 9 cause coins to be pushed over the edge of the shelf. This either causes coins to drop onto the shelf below or from the bottom shelf to a weight counter for payout; the counter recording the number of coins paid
55 out and registering the recorded number on an appropriate meter at 13.

In view of the skill involved with respect to the moving basket 7 this carries the highest award. In order to win the award a player
60 uses his skill to determine which coin slot 10 should be played at any particular time bearing in mind the position of the basket 7 during its traverse.

In order to protect the machine from abuse
65 a pendulum sensor 43 and cantilevered shock

sensor 44 are provided. Consequently, if a player strikes the machine or tries to tip it over in order to induce coins to become dislodged from the shelves 8, the sensors
70 make electrical contact with their respective contacts 45, 47 such that the machine stops all pay-outs.

CLAIMS

75 1. A game apparatus comprising a cabinet defining a playing area, means for receiving a playing piece such as a coin, token or the like, means for projecting an accepted playing
80 piece within the playing area, and a sensor, disposed within the playing area, which is triggered by a projected playing piece, the sensor or actuation by such contact, causing the apparatus to register a predetermined
85 award.

2. A game apparatus according to claim 1 wherein the sensor is movable with respect to the cabinet.

3. A game apparatus according to claim 2 including a plurality of fixed sensors disposed
90 within the playing area.

4. A game apparatus according to claim 1 or claim 2 including at least one shelf onto which projected playing pieces may fall, said shelf or shelves being traversed by pusher
95 means which push playing pieces collected thereon towards an edge of the shelf or shelves.

5. A game apparatus according to claim 3 wherein the sensors are surrounded by a
100 basket through which the playing pieces must pass in order to actuate the sensors by contact therewith.

6. A game apparatus according to claim 1 or claim 2 wherein the means for projecting
105 an accepted playing piece comprises a rotatable drum having a plurality of protruding bars therein onto which the playing piece drops by gravity to be projected into the playing area.

7. A game apparatus comprising a cabinet
110 defining a playing area, means for receiving a playing piece such as a coin, token or the like, means for projecting an accepted playing piece within the playing area, a plurality of shrouded sensors in an upper portion of the
115 playing area, at least one shelf onto which playing pieces may fall after projection, in a lower portion of the playing area, pusher means for traversing the at least one shelf surface so as to push collected playing pieces
120 towards and edge of the shelf, and means for moving at least one of said shrouded sensors within the playing area, the sensors being actuated by contact with a playing piece and being operative to cause the apparatus to
125 register a predetermined award.

8. A game apparatus according to claim 7 wherein the said at least one shrouded sensor is movable to and fro across the playing area by means of a reversible drive motor, the said
130 at least one shrouded sensor maintaining elec-

trical contact with the apparatus by means of a wiping contact with an elongate contact fixed to the cabinet.

9. A game apparatus according to claim 8
- 5 wherein the at least one shrouded sensor is disposed below a hood having a free edge projecting downwardly and forwardly of a leading edge of the said sensor.

Printed for Her Majesty's Stationery Office
by Burgess & Son (Abingdon) Ltd.—1983.
Published at The Patent Office, 25 Southampton Buildings,
London, WC2A 1AY, from which copies may be obtained.