

(19) World Intellectual Property Organization
International Bureau



(43) International Publication Date
20 January 2005 (20.01.2005)

PCT

(10) International Publication Number
WO 2005/004734 A1

- (51) International Patent Classification⁷: **A61B 18/14**
 - (21) International Application Number: PCT/US2003/018674
 - (22) International Filing Date: 13 June 2003 (13.06.2003)
 - (25) Filing Language: English
 - (26) Publication Language: English
 - (71) Applicant (for all designated States except US): **SHERWOOD SERVICES AG** [CH/CH]; Bahnhofstrasse 29, CH-8200 Schaffhausen (CH).
 - (72) Inventors; and
 - (75) Inventors/Applicants (for US only): **DYCUS, Sean, T.** [US/US]; 2226 Clarkson Street, Denver, CO 80205 (US). **KERR, Duane, Eugene** [US/US]; 300 E. Nebraska Avenue, Berthoud, CO 80513 (US). **PETERSON, Darion** [US/US]; 3095 29th Street #101, Boulder, CO 80301 (US).
 - (74) Agent: **PATENT COUNSEL**; United States Surgical, a division of Tyco Health Care Group LP, 150 Glover Avenue, Norwalk, CT 06856 (US).
 - (81) Designated States (national): AE, AG, AL, AM, AT, AU, AZ, BA, BB, BG, BR, BY, BZ, CA, CH, CN, CO, CR, CU, CZ, DE, DK, DM, DZ, EC, EE, ES, FI, GB, GD, GE, GH, GM, HR, HU, ID, IL, IN, IS, JP, KE, KG, KP, KR, KZ, LC, LK, LR, LS, LT, LU, LV, MA, MD, MG, MK, MN, MW, MX, MZ, NO, NZ, OM, PH, PL, PT, RO, RU, SC, SD, SE, SG, SK, SL, TJ, TM, TN, TR, TT, TZ, UA, UG, US, UZ, VC, VN, YU, ZA, ZM, ZW.
 - (84) Designated States (regional): ARIPO patent (GH, GM, KE, LS, MW, MZ, SD, SL, SZ, TZ, UG, ZM, ZW), Eurasian patent (AM, AZ, BY, KG, KZ, MD, RU, TJ, TM), European patent (AT, BE, BG, CH, CY, CZ, DE, DK, EE, ES, FI, FR, GB, GR, HU, IE, IT, LU, MC, NL, PT, RO, SE, SI, SK, TR), OAPI patent (BF, BJ, CF, CG, CI, CM, GA, GN, GQ, GW, ML, MR, NE, SN, TD, TG).
- Published:**
— with international search report

[Continued on next page]

(54) Title: VESSEL SEALER AND DIVIDER FOR USE WITH SMALL TROCARS AND CANNULAS

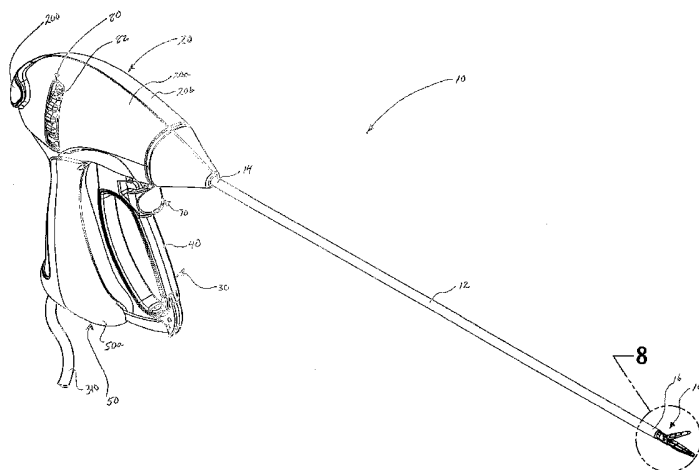

(57) Abstract: An endoscopic bipolar forceps includes a housing and a shaft affixed to the housing. The shaft includes a longitudinal axis defined therethrough and a pair of jaw members attached to a distal end thereof. The forceps also includes a drive assembly for moving one of the jaw members relative to the other jaw member from a first position wherein the movable jaw members are disposed in spaced relation relative to each other to a second position wherein the jaw members are closer one another for manipulating tissue. A movable handle is included which is rotatable about a pivot to force a drive flange of the movable handle into mechanical cooperation with the drive assembly to move the jaw members from the open and closed positions. The pivot is located a fixed distance from the longitudinal axis and the drive flange is located generally along the longitudinal axis. The forceps is connected to a source of electro-surgical energy connected to each jaw member such that the jaw member are capable of conducting bipolar energy through tissue held therebetween to effect a tissue seal.

WO 2005/004734 A1



For two-letter codes and other abbreviations, refer to the "Guidance Notes on Codes and Abbreviations" appearing at the beginning of each regular issue of the PCT Gazette.

**VESSEL SEALER AND DIVIDER FOR USE WITH SMALL
TROCARS AND CANNULAS**

5

BACKGROUND

The present disclosure relates to an electrosurgical forceps and more particularly, the present disclosure relates to an endoscopic bipolar electrosurgical forceps for sealing and/or cutting tissue.

10

Technical Field

Electrosurgical forceps utilize both mechanical clamping action and electrical energy to effect hemostasis by heating the tissue and blood vessels to coagulate, cauterize and/or seal tissue. As an alternative to open forceps for use with open surgical procedures, many modern surgeons use endoscopes and endoscopic instruments for remotely accessing organs through smaller, puncture-like incisions. As a direct result thereof, patients tend to benefit from less scarring and reduced healing time.

15

Endoscopic instruments are inserted into the patient through a cannula, or port, which has been made with a trocar. Typical sizes for cannulas range from three millimeters to twelve millimeters. Smaller cannulas are usually preferred, which, as can be appreciated, ultimately presents a design challenge to instrument manufacturers who must find ways to make endoscopic instruments that fit through the smaller cannulas.

20

25

Many endoscopic surgical procedures require cutting or ligating blood vessels or vascular tissue. Due to the inherent spatial considerations of the surgical cavity, surgeons often have difficulty suturing vessels or performing other traditional methods of controlling bleeding, e.g., clamping and/or tying-off transected blood vessels. By utilizing an endoscopic electrosurgical forceps, a surgeon can either cauterize, coagulate/desiccate and/or simply reduce or slow bleeding simply by controlling the intensity, frequency and duration of the electrosurgical energy applied through the jaw members to the tissue. Most

30

small blood vessels, i.e., in the range below two millimeters in diameter, can often be closed using standard electrosurgical instruments and techniques. However, if a larger vessel is ligated, it may be necessary for the surgeon to convert the endoscopic procedure into an open-surgical procedure and thereby
5 abandon the benefits of endoscopic surgery. Alternatively, the surgeon can seal the larger vessel or tissue.

It is thought that the process of coagulating vessels is fundamentally different than electrosurgical vessel sealing. For the purposes herein, "coagulation" is defined as a process of desiccating tissue wherein the tissue
10 cells are ruptured and dried. "Vessel sealing" or "tissue sealing" is defined as the process of liquefying the collagen in the tissue so that it reforms into a fused mass. Coagulation of small vessels is sufficient to permanently close them, while larger vessels need to be sealed to assure permanent closure.

In order to effectively seal larger vessels (or tissue) two predominant
15 mechanical parameters must be accurately controlled - the pressure applied to the vessel (tissue) and the gap distance between the electrodes - both of which are affected by the thickness of the sealed vessel. More particularly, accurate application of pressure is important to oppose the walls of the vessel; to reduce the tissue impedance to a low enough value that allows enough electrosurgical
20 energy through the tissue; to overcome the forces of expansion during tissue heating; and to contribute to the end tissue thickness which is an indication of a good seal. It has been determined that a typical fused vessel wall is optimum between 0.001 and 0.006 inches. Below this range, the seal may shred or tear and above this range the lumens may not be properly or effectively sealed.

25 With respect to smaller vessels, the pressure applied to the tissue tends to become less relevant whereas the gap distance between the electrically conductive surfaces becomes more significant for effective sealing. In other words, the chances of the two electrically conductive surfaces touching during activation increases as vessels become smaller.

30 Many known instruments include blade members or shearing members which simply cut tissue in a mechanical and/or electromechanical manner and are relatively ineffective for vessel sealing purposes. Other instruments rely on clamping pressure alone to procure proper sealing thickness and are not

designed to take into account gap tolerances and/or parallelism and flatness requirements which are parameters which, if properly controlled, can assure a consistent and effective tissue seal. For example, it is known that it is difficult to adequately control thickness of the resulting sealed tissue by controlling clamping pressure alone for either of two reasons: 1) if too much force is applied, there is a possibility that the two poles will touch and energy will not be transferred through the tissue resulting in an ineffective seal; or 2) if too low a force is applied the tissue may pre-maturely move prior to activation and sealing and/or a thicker, less reliable seal may be created.

As mentioned above, in order to properly and effectively seal larger vessels or tissue, a greater closure force between opposing jaw members is required. It is known that a large closure force between the jaws typically requires a large moment about the pivot for each jaw. This presents a design challenge because the jaw members are typically affixed with pins which are positioned to have small moment arms with respect to the pivot of each jaw member. A large force, coupled with a small moment arm, is undesirable because the large forces may shear the pins. As a result, designers must compensate for these large closure forces by either designing instruments with metal pins and/or by designing instruments which at least partially offload these closure forces to reduce the chances of mechanical failure. As can be appreciated, if metal pivot pins are employed, the metal pins must be insulated to avoid the pin acting as an alternate current path between the jaw members which may prove detrimental to effective sealing.

Increasing the closure forces between electrodes may have other undesirable effects, e.g., it may cause the opposing electrodes to come into close contact with one another which may result in a short circuit and a small closure force may cause pre-mature movement of the tissue during compression and prior to activation. As a result thereof, providing an instrument which consistently provides the appropriate closure force between opposing electrode within a preferred pressure range will enhance the chances of a successful seal. As can be appreciated, relying on a surgeon to manually provide the appropriate closure force within the appropriate range on a consistent basis would be difficult and the resultant effectiveness and quality of

the seal may vary. Moreover, the overall success of creating an effective tissue seal is greatly reliant upon the user's expertise, vision, dexterity, and experience in judging the appropriate closure force to uniformly, consistently and effectively seal the vessel. In other words, the success of the seal would
5 greatly depend upon the ultimate skill of the surgeon rather than the efficiency of the instrument.

It has been found that the pressure range for assuring a consistent and effective seal is between about 3 kg/cm² to about 16 kg/cm² and, preferably, within a working range of 7 kg/cm² to 13 kg/cm². Manufacturing an instrument
10 which is capable of providing a closure pressure within this working range has been shown to be effective for sealing arteries, tissues and other vascular bundles.

Various force-actuating assemblies have been developed in the past for providing the appropriate closure forces to effect vessel sealing. For example,
15 one such actuating assembly has been developed by Valleylab Inc., a division of Tyco Healthcare LP, for use with Valleylab's vessel sealing and dividing instrument commonly sold under the trademark LIGASURE ATLAS[®]. This assembly includes a four-bar mechanical linkage, a spring and a drive assembly which cooperate to consistently provide and maintain tissue
20 pressures within the above working ranges. The LIGASURE ATLAS[®] is presently designed to fit through a 10mm cannula and includes a bi-lateral jaw closure mechanism which is activated by a foot switch. A trigger assembly extends a knife distally to separate the tissue along the tissue seal. A rotating mechanism is associated with distal end of the handle to allow a surgeon to
25 selectively rotate the jaw members to facilitate grasping tissue. Co-pending U.S. Application Serial Nos. 10/179,863 and 10/116,944 and PCT Application Serial Nos. PCT/US01/01890 and PCT/7201/11340 describe in detail the operating features of the LIGASURE ATLAS[®] and various methods relating thereto. The contents of all of these applications are hereby incorporated by
30 reference herein.

It would be desirable to develop a smaller, simpler endoscopic vessel sealing instrument which can be utilized with a 5mm cannula. Preferably, the instrument would include a simpler and more mechanically advantageous drive

assembly to facilitate grasping and manipulating vessels and tissue. In addition, it would be desirous to manufacture an instrument which includes a hand switch and a unilateral jaw closure mechanism.

5

SUMMARY

The present disclosure relates to an endoscopic bipolar forceps which is designed to be utilized with a 5mm trocar or cannula and includes a housing and a shaft affixed to the distal end of the housing. Preferably, the shaft includes a reduced diameter such that the shaft is freely insertable through the trocar. The shaft also includes a longitudinal axis defined therethrough and a pair of first and second jaw members attached to a distal end thereof. The forceps includes a drive assembly for moving the first jaw member relative to the second member from a first position wherein the jaw members are disposed in spaced relation relative to each other to a second position wherein the jaw members cooperate to grasp tissue therebetween. A movable handle is included which is rotatable about a pivot located above the longitudinal axis of the shaft. Movement of the handle engages a drive flange into mechanical cooperation with the drive assembly to move the jaw members from the open and closed positions. Advantageously, the pivot is located a fixed distance above the longitudinal axis to provide lever-like mechanical advantage to the drive flange. The drive flange is located generally along the longitudinal axis. The forceps is connected to a source of electrosurgical energy which carries electrical potentials to each respective jaw member such that the jaw members are capable of conducting bipolar energy through tissue held therebetween to effect a tissue seal.

25

In yet another embodiment, the forceps includes a hand switch disposed within the housing which is electromechanically connected to the energy source. Advantageously, the hand switch allows a user to selectively supply bipolar energy to the jaw members to effect a tissue seal.

30

In one embodiment, the forceps includes a selectively advanceable knife assembly for cutting tissue in a forward direction along the tissue seal. A rotating assembly may also be included for rotating the jaw members about the longitudinal axis defined through the shaft. Advantageously, the rotating

assembly is located proximal to the driving flange and near the hand switch to facilitate rotation.

Preferably, the movable jaw member includes a first electrical potential and the fixed jaw member includes a second electrical potential. A lead
5 connects the movable jaw member to the first potential and a conductive tube (which is disposed through the shaft) conducts a second electrical potential to the fixed jaw member. Advantageously, the conductive tube is connected to the rotating assembly to permit selective rotation of the jaw members.

In one embodiment, the drive assembly includes a reciprocating sleeve
10 which upon activation of the movable handle, translates atop the rotating conductive tube to move the movable jaw member relative to the fixed jaw member. Preferably, the movable jaw member includes a detent which extends beyond the fixed jaw member which is designed for engagement with the reciprocating sleeve such that, upon translation thereof, the movable jaw
15 member moves relative to the fixed jaw member. Advantageously, a spring is included with the drive assembly to facilitate actuation of the movable handle and to assure the closure force is maintained within the working range of about 3kg/cm^2 to about 16 kg/cm^2 and, preferably, about 7 kg/cm^2 to about 13 kg/cm^2

Preferably, at least one of the jaw members includes a series of stop
20 members disposed thereon for regulating the distance between the jaw members (i.e., creating a gap between the two opposing jaw members) during the sealing process. As can be appreciated, regulating the gap distance between opposing jaw members along with maintaining the closing pressure to within the above-described ranges will produce a reliable and consistent tissue
25 seal.

The present disclosure also relates to an endoscopic bipolar forceps which includes a shaft having a movable jaw member and a fixed jaw member at a distal end thereof. The forceps also includes a drive assembly for moving the movable jaw member relative to the fixed jaw member from a first position
30 wherein the movable jaw member is disposed in spaced relation relative to the fixed jaw member to a second position wherein the movable jaw member is closer to the fixed jaw member for manipulating tissue. A movable handle is included which actuates the drive assembly to move the movable jaw member.

The forceps connects to a source of electrosurgical energy which is conducted to each jaw member such that the jaw members are capable of conducting bipolar energy through tissue held therebetween to effect a tissue seal. Advantageously, the forceps also includes a selectively advanceable
5 knife assembly for cutting tissue in a distal direction along the tissue seal and a stop member disposed on at least one of the jaw members for regulating the distance between jaw members during sealing.

BRIEF DESCRIPTION OF THE DRAWINGS

10 Various embodiments of the subject instrument are described herein with reference to the drawings wherein:

Fig. 1 is a left, perspective view of an endoscopic bipolar forceps showing a housing, a shaft and an end effector assembly according to the present disclosure;

15 Fig. 2 is a top view of the forceps of Fig. 1;

Fig. 3 is a left, side view of the forceps of Fig. 1;

Fig. 4 is a left, perspective view of the forceps of Fig. 1 showing the rotation of the end effector assembly about a longitudinal axis "A";

Fig. 5 is a front view of the forceps of Fig. 1;

20 Figs. 6 is an enlarged view of the indicated area of detail of Fig. 5 showing an enhanced view of the end effector assembly detailing a pair of opposing jaw members;

Fig. 7 is an enlarged, rear perspective view of the housing;

25 Fig. 8 is an enlarged, left perspective view of the end effector assembly with the jaw members shown in open configuration;

Fig. 9 is an enlarged, side view of the end effector assembly;

Fig. 10 is an enlarged, perspective view of the underside of the upper jaw member of the end effector assembly;

30 Fig. 11 is an enlarged, broken perspective view showing the end effector assembly and highlighting a cam-like closing mechanism which cooperates with a reciprocating pull sleeve to move the jaw members relative to one another;

Fig. 12 is a full perspective view of the end effector assembly of Fig. 11;

Fig. 13 is an enlarged, perspective view of the housing and the internal working components thereof;

Fig. 14 is top, perspective view of the housing of Fig. 13 with parts separated;

5 Fig. 15 is a left, perspective view of a rotating assembly, drive assembly, knife assembly and lower jaw member according to the present disclosure;

Fig. 16 is a rear, perspective view of the rotating assembly, drive assembly and knife assembly;

10 Fig. 17 is an enlarged, top, perspective view of the end effector assembly with parts separated;

Fig. 18 is an enlarged, perspective view of the knife assembly;

Fig. 19 is an enlarged, perspective view of the rotating assembly;

Fig. 20 is an enlarged, perspective view of the drive assembly;

15 Fig. 21 is an enlarged, perspective view of the knife assembly with parts separated;

Fig. 22 is an enlarged view of the indicated area of detail of Fig. 21;

Fig. 23 is a greatly-enlarged, perspective view of a distal end of the knife assembly;

20 Fig. 24 is a greatly-enlarged, perspective view of a knife drive of the knife assembly;

Fig. 25 is an enlarged, perspective view of the rotating assembly and lower jaw member with parts separated;

Fig. 26 is a cross section of the area indicated in detail in Fig. 25;

Fig. 27 is a greatly-enlarged, perspective view of the lower jaw member;

25 Fig. 28 is an enlarged, perspective view of the drive assembly;

Fig. 29 is an enlarged perspective view of the drive assembly of Fig. 28 with parts separated;

Fig. 30 is an internal, side view of the housing showing the inner-working components thereof;

30 Fig. 31 is a cross-section of the housing with the end effector shown in open configuration and showing the internal, electrical routing of an electro-surgical cable and electrical leads;

Fig. 32 is a greatly-enlarged view of the indicated area of detail of Fig. 31;

Fig. 33 is a greatly-enlarged view of the indicated area of detail of Fig. 31;

5 Fig. 34 is a greatly-enlarged, cross section of the shaft taken along line 34-34;

Fig. 35 is a side, cross section of the shaft and end effector assembly;

Fig. 36 is a perspective view showing the forceps of the present disclosure being utilized with a 5mm cannula;

10 Fig. 37 is a side, cross section of the housing showing the moving components of the drive assembly during actuation;

Fig. 38 is a greatly-enlarged, perspective view of a handle locking mechanism for use with the drive assembly;

15 Fig. 39 is a greatly-enlarged view of the indicated area of detail in Fig. 37;

Fig. 40 is a greatly-enlarged view of the indicated area of detail in Fig. 37;

Fig. 41 is an enlarged, rear, perspective view of the end effectors shown grasping tissue;

20 Fig. 42 is an enlarged view of a tissue seal;

Fig. 43 is a side, cross section of a tissue seal;

Fig. 44 is a cross section of the housing with the handle in a locked configuration and showing the moving components of the knife assembly during activation;

25 Fig. 45 is an enlarged view of the area indicated in detail in Fig. 44;

Fig. 46 is a side, cross section of a tissue seal after separation by the knife assembly;

30 Fig. 47 is a side, cross section of the housing showing the release of the knife assembly and release of the drive assembly to open the jaw members and release the tissue;

Fig. 48 is a greatly-enlarged view of the indicated area of detail in Fig. 47; and

Fig. 49 is a greatly-enlarged view of the indicated area of detail in Fig. 47.

DETAILED DESCRIPTION

5 Turning now to Figs. 1-3, one embodiment of an endoscopic bipolar forceps 10 is shown for use with various surgical procedures and generally includes a housing 20, a handle assembly 30, a rotating assembly 80, a trigger assembly 70 and an end effector assembly 100 which mutually cooperate to grasp, seal and divide tubular vessels and vascular tissue 420 (Fig. 36).
10 Although the majority of the figure drawings depict a bipolar forceps 10 for use in connection with endoscopic surgical procedures, the present disclosure may be used for more traditional open surgical procedures. For the purposes herein, the forceps 10 is described in terms of an endoscopic instrument, however, it is contemplated that an open version of the forceps may also
15 include the same or similar operating components and features as described below.

Forceps 10 includes a shaft 12 which has a distal end 16 dimensioned to mechanically engage the end effector assembly 100 and a proximal end 14 which mechanically engages the housing 20. Details of how the shaft 12
20 connects to the end effector are described in more detail below with respect to Fig. 25. The proximal end 14 of shaft 12 is received within the housing 20 and the connections relating thereto are described in detail below with respect to Figs. 13 and 14. In the drawings and in the descriptions which follow, the term "proximal", as is traditional, will refer to the end of the forceps 10 which is
25 closer to the user, while the term "distal" will refer to the end which is further from the user.

As best seen in Fig. 1, forceps 10 also includes an electrosurgical cable 310 which connects the forceps 10 to a source of electrosurgical energy, e.g., a generator (not shown). Preferably, generators such as those sold by
30 Valleylab - a division of Tyco Healthcare LP, located in Boulder Colorado are used as a source of electrosurgical energy, e.g., FORCE EZ™ Electrosurgical Generator, FORCE FX™ Electrosurgical Generator, FORCE 1C™, FORCE 2™ Generator, SurgiStat™ II. One such system is described in commonly-owned

U.S. Patent No. 6,033,399 entitled "ELECTROSURGICAL GENERATOR WITH ADAPTIVE POWER CONTROL" the entire contents of which are hereby incorporated by reference herein. Other systems have been described in commonly-owned U.S. Patent No. 6,187,003 entitled "BIPOLAR
5 ELECTROSURGICAL INSTRUMENT FOR SEALING VESSELS" the entire contents of which is also incorporated by reference herein.

Preferably, the generator includes various safety and performance features including isolated output, independent activation of accessories. Preferably, the electrosurgical generator includes Valleylab's Instant
10 Response™ technology features which provides an advanced feedback system to sense changes in tissue 200 times per second and adjust voltage and current to maintain appropriate power. The Instant Response™ technology is believed to provide one or more of the following benefits to surgical procedure:

- 15
- Consistent clinical effect through all tissue types;
 - Reduced thermal spread and risk of collateral tissue damage;
 - Less need to "turn up the generator"; and
 - Designed for the minimally invasive environment.

Cable 310 is internally divided into cable lead 310a, 310b and 310c
20 which each transmit electrosurgical energy through their respective feed paths through the forceps 10 to the end effector assembly 100 as explained in more detail below with respect to Figs. 14 and 30.

Handle assembly 30 includes a fixed handle 50 and a movable handle
40. Fixed handle 50 is integrally associated with housing 20 and handle 40 is
25 movable relative to fixed handle 50 as explained in more detail below with respect to the operation of the forceps 10. Rotating assembly 80 is preferably integrally associated with the housing 20 and is rotatable approximately 180 degrees in either direction about a longitudinal axis "A" (See Fig. 4). Details of the rotating assembly 80 are described in more detail with respect to Figs. 13,
30 14, 15 and 16

As best seen in Figs. 2, 13 and 14, housing 20 is formed from two (2) housing halves 20a and 20b which each include a plurality of interfaces 27a-27f which are dimensioned to mechanically align and engage one another to form housing 20 and enclose the internal working components of forceps 10.

5 As can be appreciated, fixed handle 50 which, as mentioned above, is integrally associated with housing 20, takes shape upon the assembly of the housing halves 20a and 20b.

It is envisioned that a plurality of additional interfaces (not shown) may be disposed at various points around the periphery of housing halves 20a and 20b for ultrasonic welding purposes, e.g., energy direction/deflection points. It is also contemplated that housing halves 20a and 20b (as well as the other components described below) may be assembled together in any fashion known in the art. For example, alignment pins, snap-like interfaces, tongue and groove interfaces, locking tabs, adhesive ports, etc. may all be utilized either alone or in combination for assembly purposes.

Rotating assembly 80 includes two halves 82a and 82b which, when assembled, form the rotating assembly 80 which, in turn, houses the drive assembly 150 and the knife assembly 140 (See Figs. 13, 14 and 25). Half 80a includes a series of detents/flanges 375a, 375b, 375c and 375d (Fig. 25) which are dimensioned to engage a pair of corresponding sockets or other mechanical interfaces (not shown) disposed within rotating half 80a. Movable handle 40 and trigger assembly 70 are preferably of unitary construction and are operatively connected to the housing 20 and the fixed handle 50 during the assembly process.

As mentioned above, end effector assembly 100 is attached at the distal end 14 of shaft 12 and includes a pair of opposing jaw members 110 and 120. Movable handle 40 of handle assembly 30 is ultimately connected to a drive assembly 150 which, together, mechanically cooperate to impart movement of the jaw members 110 and 120 from an open position wherein the jaw members 110 and 120 are disposed in spaced relation relative to one another, to a clamping or closed position wherein the jaw members 110 and 120 cooperate to grasp tissue 420 (Fig. 36) therebetween.

It is envisioned that the forceps 10 may be designed such that it is fully or partially disposable depending upon a particular purpose or to achieve a particular result. For example, end effector assembly 100 may be selectively and releasably engageable with the distal end 16 of the shaft 12 and/or the proximal end 14 of shaft 12 may be selectively and releasably engageable with the housing 20 and the handle assembly 30. In either of these two instances, the forceps 10 would be considered "partially disposable" or "reposable", i.e., a new or different end effector assembly 100 (or end effector assembly 100 and shaft 12) selectively replaces the old end effector assembly 100 as needed. As can be appreciated, the presently disclosed electrical connections would have to be altered to modify the instrument to a reposable forceps.

Turning now to the more detailed features of the present disclosure as described with respect to Figs. 1 - 14, movable handle 40 includes a finger loop 41 which has an aperture 42 defined therethrough which enables a user to grasp and move the handle 40 relative to the fixed handle 50. Handle 40 also includes an ergonomically-enhanced gripping element 43 disposed along the inner peripheral edge of aperture 42 which is designed to facilitate gripping of the movable handle 40 during activation. It is envisioned that gripping element 43 may include one or more protuberances, scallops and/or ribs to enhance gripping. As best seen in Fig. 14, movable handle 40 is selectively moveable about a pair of pivot pins 29a and 29b from a first position relative to fixed handle 50 to a second position in closer proximity to the fixed handle 50 which, as explained below, imparts movement of the jaw members 110 and 120 relative to one another. The movable handle include a clevis 45 which forms a pair of upper flanges 45a and 45b each having an aperture 49a and 49b, respectively, at an upper end thereof for receiving the pivot pins 29a and 29b therethrough and mounting the upper end of the handle 40 to the housing 20. In turn, each pin 29a and 29b mounts to a respective housing half 20a and 20b.

Each upper flange 45a and 45b also includes a force-actuating flange or drive flange 47a and 47b, respectively, which are aligned along longitudinal axis "A" and which abut the drive assembly 150 such that pivotal movement of the handle 40 forces actuating flange against the drive assembly 150 which, in

turn, closes the jaw members 110 and 120. For the purposes herein, 47a and 47b which act simultaneously on the drive assembly are referred to as "driving flange 47". A more detailed explanation of the inter-cooperating components of the handle assembly 30 and the drive assembly 150 is discussed below.

5 As best seen in Fig. 14, the lower end of the movable handle 40 includes a flange 90 which is preferably mounted to the movable handle 40 by pins 94a and 94b which engage a corresponding pair of apertures 91a and 91b disposed within the lower portion of handle 40 and apertures 97a and 97b disposed within flange 90, respectively. Other methods of engagement are
10 also contemplated, snap-lock, spring tab, etc. Flange 90 also includes a t-shaped distal end 95 which rides within a predefined channel 51 disposed within fixed handle 50 to lock the movable handle 40 relative to the fixed handle 50. Additional features with respect to the t-shaped end 95 are explained below in the detailed discussion of the operational features of the
15 forceps 10.

Movable handle 40 is designed to provide a distinct mechanical advantage over conventional handle assemblies due to the unique position of the pivot pins 29a and 29b (i.e., pivot point) relative to the longitudinal axis "A" of the shaft 12 and the disposition of the driving flange 47 along longitudinal
20 axis "A". In other words, it is envisioned that by positioning the pivot pins 29a and 29b above the driving flange 47, the user gains lever-like mechanical advantage to actuate the jaw members 110 and 120 enabling the user to close the jaw members 110 and 120 with lesser force while still generating the required forces necessary to effect a proper and effective tissue seal. It is also
25 envisioned that the unilateral design of the end effector assembly 100 will also increase mechanical advantage as explained in more detail below.

As shown best in Figs. 6-12, the end effector assembly 100 includes opposing jaw members 110 and 120 which cooperate to effectively grasp tissue 420 for sealing purposes. The end effector assembly 100 is designed
30 as a unilateral assembly, i.e., jaw member 120 is fixed relative to the shaft 12 and jaw member 110 pivots about a pivot pin 103 to grasp tissue 420.

More particularly, the unilateral end effector assembly 100 includes one stationary or fixed jaw member 120 mounted in fixed relation to the shaft 12

and pivoting jaw member 110 mounted about a pivot pin 103 attached to the stationary jaw member 120. A reciprocating sleeve 60 is slidingly disposed within the shaft 12 and is remotely operable by the drive assembly 150. The pivoting jaw member 110 includes a detent or protrusion 117 which extends
5 from jaw member 110 through an aperture 62 disposed within the reciprocating sleeve 60 (Fig. 12). The pivoting jaw member 110 is actuated by sliding the sleeve 60 axially within the shaft 12 such that a distal end 63 of the aperture 62 abuts against the detent 117 on the pivoting jaw member 110 (See Figs. 11 and 12). Pulling the sleeve 60 proximally closes the jaw members 110 and 120
10 about tissue 420 grasped therebetween and pushing the sleeve 60 distally opens the jaw members 110 and 120 for grasping purposes.

As best illustrated in Figs. 8 and 10, a knife channel 115a and 115b runs through the center of the jaw members 110 and 120, respectively, such that a blade 185 from the knife assembly 140 can cut the tissue 420 grasped
15 between the jaw members 110 and 120 when the jaw members 110 and 120 are in a closed position. More particularly, the blade 185 can only be advanced through the tissue 420 when the jaw members 110 and 120 are closed thus preventing accidental or premature activation of the blade 185 through the tissue 420. Put simply, the knife channel 115 (made up of half channels 115a and 115b) is blocked when the jaws members 110 and 120 are opened and
20 aligned for distal activation when the jaw members 110 and 120 are closed (See Figs. 35 and 39). It is also envisioned that the unilateral end effector assembly 100 may be structured such that electrical energy can be routed through the sleeve 60 at the protrusion 117 contact point with the sleeve 60 or
25 using a "brush" or lever (not shown) to contact the back of the moving jaw member 110 when the jaw member 110 closes. In this instance, the electrical energy would be routed through the protrusion 117 to the stationary jaw member 120. Alternatively, the cable lead 311 may be routed to energize the stationary jaw member 120 and the other electrical potential may be conducted
30 through the sleeve 60 and transferred to the pivoting jaw member 110 which establishes electrical continuity upon retraction of the sleeve 60. It is envisioned that this particular envisioned embodiment will provide at least two important safety features: 1) the blade 185 cannot extend while the jaw

members 110 and 120 are opened; and 2) electrical continuity to the jaw members 110 and 120 is made only when the jaw members are closed. The illustrated forceps 10 only includes the novel knife channel 115.

As best shown in Fig. 8, jaw member 110 also includes a jaw housing 5 116 which has an insulative substrate or insulator 114 and an electrically conductive surface 112. Insulator 114 is preferably dimensioned to securely engage the electrically conductive sealing surface 112. This may be accomplished by stamping, by overmolding, by overmolding a stamped electrically conductive sealing plate and/or by overmolding a metal injection 10 molded seal plate. For example and as shown in Fig. 17, the electrically conductive sealing plate 112 includes a series of upwardly extending flanges 111a and 111b which are designed to matingly engage the insulator 114. The insulator 114 includes a shoe-like interface 107 disposed at a distal end thereof which is dimensioned to engage the outer periphery 116a of the housing 116 in 15 a slip-fit manner. The shoe-like interface 107 may also be overmolded about the outer periphery of the jaw 110 during a manufacturing step. It is envisioned that lead 311 terminates within the shoe-like interface 107 at the point where lead 311 electrically connects to the seal plate 112 (not shown). The movable jaw member 110 also includes a wire channel 113 which is designed to guide 20 cable lead 311 into electrical continuity with sealing plate 112 as described in more detail below.

All of these manufacturing techniques produce jaw member 110 having an electrically conductive surface 112 which is substantially surrounded by an insulating substrate 114. The insulator 114, electrically conductive sealing 25 surface 112 and the outer, non-conductive jaw housing 116 are preferably dimensioned to limit and/or reduce many of the known undesirable effects related to tissue sealing, e.g., flashover, thermal spread and stray current dissipation. Alternatively, it is also envisioned that the jaw members 110 and 120 may be manufactured from a ceramic-like material and the electrically 30 conductive surface(s) 112 are coated onto the ceramic-like jaw members 110 and 120.

Jaw member 110 includes a pivot flange 118 which includes protrusion 117. Protrusion 117 extends from pivot flange 118 and includes an arcuately-

shaped inner surface 111 dimensioned to matingly engage the aperture 62 of sleeve 60 upon retraction thereof. Pivot flange 118 also includes a pin slot 119 which is dimensioned to engage pivot pin 103 to allow jaw member 110 to rotate relative to jaw member 120 upon retraction of the reciprocating sleeve 60. As explained in more detail below, pivot pin 103 also mounts to the stationary jaw member 120 through a pair of apertures 101a and 101b disposed within a proximal portion of the jaw member 120.

It is envisioned that the electrically conductive sealing surface 112 may also include an outer peripheral edge which has a pre-defined radius and the insulator 114 meets the electrically conductive sealing surface 112 along an adjoining edge of the sealing surface 112 in a generally tangential position. Preferably, at the interface, the electrically conductive surface 112 is raised relative to the insulator 114. These and other envisioned embodiments are discussed in co-pending, commonly assigned Application Serial No. PCT/US01/11412 entitled "ELECTROSURGICAL INSTRUMENT WHICH REDUCES COLLATERAL DAMAGE TO ADJACENT TISSUE" by Johnson et al. and co-pending, commonly assigned Application Serial No. PCT/US01/11411 entitled "ELECTROSURGICAL INSTRUMENT WHICH IS DESIGNED TO REDUCE THE INCIDENCE OF FLASHOVER" by Johnson et al.

Preferably, the electrically conductive surface 112 and the insulator 114, when assembled, form a longitudinally-oriented slot 115a defined therethrough for reciprocation of the knife blade 185. It is envisioned that the knife channel 115a cooperates with a corresponding knife channel 115b defined in stationary jaw member 120 to facilitate longitudinal extension of the knife blade 185 along a preferred cutting plane to effectively and accurately separate the tissue 420 along the formed tissue seal 450 (See Figs. 42 and 46).

Jaw member 120 includes similar elements to jaw member 110 such as jaw housing 126 having an insulator 124 and an electrically conductive sealing surface 122 which is dimensioned to securely engage the insulator 124. Likewise, the electrically conductive surface 122 and the insulator 124, when assembled, include a longitudinally-oriented channel 115a defined therethrough for reciprocation of the knife blade 185. As mentioned above,

when the jaw members 110 and 120 are closed about tissue 420, knife channels 115a and 115b form a complete knife channel 115 to allow longitudinal extension of the knife 185 in a distal fashion to sever tissue 420 along the tissue seal 450. It is also envisioned that the knife channel 115 may
5 be completely disposed in one of the two jaw members, e.g., jaw member 120, depending upon a particular purpose. It is envisioned that the fixed jaw member 120 may be assembled in a similar manner as described above with respect to jaw member 110.

As best seen in Fig. 8, jaw member 120 includes a series of stop
10 members 750 preferably disposed on the inner facing surfaces of the electrically conductive sealing surface 122 to facilitate gripping and manipulation of tissue and to define a gap "G" (Fig. 24) between opposing jaw members 110 and 120 during sealing and cutting of tissue. It is envisioned that the series of stop members 750 may be employed on one or both jaw
15 members 110 and 120 depending upon a particular purpose or to achieve a desired result. A detailed discussion of these and other envisioned stop members 750 as well as various manufacturing and assembling processes for attaching and/or affixing the stop members 750 to the electrically conductive sealing surfaces 112, 122 are described in commonly-assigned, co-pending
20 U.S. Application Serial No. PCT/US01/11413 entitled "VESSEL SEALER AND DIVIDER WITH NON-CONDUCTIVE STOP MEMBERS" by Dycus et al. which is hereby incorporated by reference in its entirety herein.

Jaw member 120 is designed to be fixed to the end of a rotating tube
25 160 which is part of the rotating assembly 80 such that rotation of the tube 160 will impart rotation to the end effector assembly 100 (See Figs. 25 and 27). Jaw member 120 includes a rear C-shaped cuff 170 having a slot 177 defined therein which is dimensioned to receive a slide pin 171. More particularly, slide pin 171 includes a slide rail 176 which extends substantially the length thereof which is dimensioned to slide into friction-fit engagement within slot
30 177. A pair of chamfered plates 172a and 172b extend generally radially from the slide rail 176 and include a radius which is substantially the same radius as the outer periphery of the rotating tube 160 such that the shaft 12 can encompass each of the same upon assembly.

As explained in more detail below, fixed jaw member 120 is connected to a second electrical potential through tube 160 which is connected at its proximal end to lead 310c. More particularly, fixed jaw 120 is welded to the rotating tube 160 and includes a fuse clip, spring clip or other electro-
5 mechanical connection which provides electrical continuity to the fixed jaw member 120 from lead 310c (See Fig. 32). As best shown in Figs. 25 and 26, the rotating tube 160 includes an elongated guide slot 167 disposed in an upper portion thereof which is dimensioned to carry lead 311 therealong. The chamfered plates 172a and 172b also form a wire channel 175 which is
10 dimensioned to guide the cable lead 311 from the tube 160 and into the movable jaw member 110 (See Fig. 8). Lead 311 carries a first electrical potential to movable jaw 110. As explained in more detail below with respect to the internal electrical connections of the forceps, a second electrical connection from lead 310c is conducted through the tube 160 to the fixed jaw
15 member 120.

As shown in Fig. 25, the distal end of the tube 160 is generally C-shaped to include two upwardly extending flanges 162a and 162b which define a cavity 165 for receiving the proximal end of the fixed jaw member 120 inclusive of C-shaped cuff 170 and slide pin 171 (See Fig. 27). Preferably, the
20 tube cavity 165 retains and secures the jaw member 120 in a friction-fit manner, however, the jaw member 120 may be welded to the tube 160 depending upon a particular purpose. Tube 160 also includes an inner cavity 169 defined therethrough which reciprocates the knife assembly 140 upon distal activation thereof and an elongated guide rail 163 which guides the knife
25 assembly 140 during distal activation. The details with respect to the knife assembly are explained in more detail with respect to Figs. 21-24. The proximal end of tube 160 includes a laterally oriented slot 168 which is designed to interface with the rotating assembly 80 as described below.

Fig. 25 also shows the rotating assembly 80 which includes C-shaped
30 rotating halves 82a and 82b which, when assembled about tube 160, form a generally circular rotating member 82. More particularly, each rotating half, e.g., 82b, includes a series of mechanical interfaces 375a, 375b, 375c and 375d which matingly engage a corresponding series of mechanical interfaces

in half 82a to form rotating member 82. Half 82b also includes a tab 89b which together with a corresponding tab 89a disposed on half 82a (phantomly illustrated) cooperate to matingly engage slot 168 disposed on tube 160. As can be appreciated, this permits selective rotation of the tube 160 about axis "A" by manipulating the rotating member 82 in the direction of the arrow "B" (see Fig. 4).

As best shown in the exploded view of Fig. 17, jaw members 110 and 120 are pivotably mounted with respect to one another such that jaw member 110 pivots in a unilateral fashion from a first open position to a second closed position for grasping and manipulating tissue 420. More particularly, fixed jaw member 120 includes a pair of proximal, upwardly extending flanges 125a and 125b which define a cavity 121 dimensioned to receive flange 118 of movable jaw member 110 therein. Each of the flanges 125a and 125b includes an aperture 101a and 101b, respectively, defined therethrough which secures pivot pin 103 on opposite sides of pivot mount 119 disposed within jaw member 110. As explained in detail below with respect to the operation of the jaw members 110 and 120, proximal movement of the tube 60 engages detent 117 to pivot the jaw member 110 to a closed position.

Figs. 13 and 14 show the details of the housing 20 and the component features thereof, namely, the drive assembly 150, the rotating assembly 80, the knife assembly 140, the trigger assembly 70 and the handles 40 and 50. More particularly, Fig. 13 shows the above-identified assemblies and components in an assembled form in the housing 20 and Fig. 14 shows an exploded view of each of the above-identified assemblies and components.

As shown best in Fig. 14, the housing includes halves 20a and 20b which, when mated, form housing 20. As can be appreciated, housing 20, once formed, houses the various assemblies identified above which will enable a user to selectively manipulate, grasp, seal and sever tissue 420 in a simple, effective, and efficient manner. Preferably, each half of the housing, e.g., half 20b, includes a series of mechanical interfacing component, e.g., 27a - 27f which align and/or mate with a corresponding series of mechanical interfaces (not shown) to align the two housing halves 20a and 20b about the inner components and assemblies. The housing halves 20a and 20b are then

preferably sonic welded to secure the housing halves 20a and 20b once assembled.

As mentioned above, the movable handle 40 includes clevis 45 which forms upper flanges 45a and 45b which pivot about pins 29a and 29b to pull
5 the reciprocating sleeve 60 along longitudinal axis "A" and force during flange 47 against the drive assembly 150 which, in turn, closes the jaw members 110 and 120. As mentioned above, the lower end of the movable handle 40 includes a flange 90 which has a t-shaped distal end 95 which rides within a predefined channel 51 disposed within fixed handle 50 to lock the movable
10 handle 40 in a preset orientation relative to the fixed handle 50. The arrangement of the upper flanges 45a and 45b and the pivot point of the movable handle 40 provides a distinct mechanical advantage over conventional handle assemblies due to the unique position of the pivot pins 29a and 29b (i.e., pivot point) relative to the longitudinal axis "A" of the driving
15 flange 47. In other words, by positioning the pivot pins 29a and 29b above the driving flange 47, the user gains lever-like mechanical advantage to actuate the jaw members 110 and 120. This reduces the overall amount of mechanical force necessary to close the jaw members 110 and 120 to effect a tissue seal.

Handle 40 also includes a finger loop 41 which defines opening 42
20 which is dimensioned to facilitate grasping the handle 40. Preferably, finger loop 41 includes rubber insert 43 which enhances the overall ergonomic "feel" of the handle member 40. A locking flange 44 is disposed on the outer periphery of the handle member 40 above the finger loop 41. Locking flange 44 prevents the trigger assembly 70 from firing when the handle member 40 is oriented in a non-actuated position, i.e., the jaw members 110 and 120 are open. As can be appreciated, this prevents accidental or premature severing
25 of tissue 420 prior to completion of the tissue seal 450.

Fixed handle 50 includes halves 50a and 50b which, when assembled, form handle 50. Fixed handle 50 includes a channel 51 defined therein which
30 is dimensioned to receive flange 90 in a proximal moving manner when movable handle 40 is actuated. The t-shaped free end 95 of handle 40 is dimensioned for facile reception within channel 51 of handle 50. It is envisioned that flange 90 may be dimensioned to allow a user to selectively,

progressively and/or incrementally move jaw members 110 and 120 relative to one another from the open to closed positions. For example, it is also contemplated that flange 90 may include a ratchet-like interface which lockingly engages the movable handle 40 and, therefore, jaw members 110 and 120 at selective, incremental positions relative to one another depending upon a particular purpose. Other mechanisms may also be employed to control and/or limit the movement of handle 40 relative to handle 50 (and jaw members 110 and 120) such as, e.g., hydraulic, semi-hydraulic, linear actuator(s), gas-assisted mechanisms and/or gearing systems.

As best illustrated in Fig. 13, housing halves 20a and 20b when assembled form an internal cavity 52 which predefines the channel 51 within fixed handle 50 such that an entrance pathway 54 and an exit pathway 58 are formed for reciprocation of the t-shaped flange end 95 therein. When assembled, two generally triangular-shaped members 57 (one disposed in each handle half 50a and 50b) are positioned in close abutment relative to one another to define a rail or track 192 therebetween. During movement of the flange 90 along the entrance and exit pathways 54 and 58, respectively, the t-shaped end 95 rides along track 192 between the two triangular members 57 according to the particular dimensions of the triangularly-shaped members 57, which, as can be appreciated, predetermines part of the overall pivoting motion of handle 40 relative to fixed handle 50.

Once actuated, handle 40 moves in a generally arcuate fashion towards fixed handle 50 about pivot pins 29a and 29b which forces driving flange 47 proximally against the drive assembly 150 which, in turn, pulls reciprocating sleeve 60 in a generally proximal direction to close jaw member 110 relative to jaw member 120. Moreover, proximal rotation of the handle 40 causes the locking flange 44 to release, i.e., "unlock", the trigger assembly 70 for selective actuation. This feature is shown in detail with reference to Figs. 33, 37 and 44 and the explanation of the operation of the knife assembly 70 explained below.

The operating features and relative movements of the internal working components of the forceps 10 are shown by phantom representation in the various figures. As mentioned above, when the forceps 10 is assembled a predefined channel 52 is formed within the fixed handle 50. The channel

includes entrance pathway 51 and an exit pathway 58 for reciprocation of the flange 90 and the t-shaped end 95 therein. Once assembled, the two generally triangular-shaped members 57 are positioned in close abutment relative to one another and define track 192 disposed therebetween.

5 As the handle 40 is squeezed and flange 90 is incorporated into channel 51 of fixed handle 50, the driving flange 47, through the mechanical advantage of the above-the-center pivot points, biases flange 154 of drive ring 159 which, in turn, compresses a spring 67 against a rear ring 156 of the drive assembly 150 (Fig. 40). As a result thereof, the rear ring 156 reciprocates sleeve 60
10 proximally which, in turn, closes jaw member 110 onto jaw member 120. It is envisioned that the utilization of an over-the-center pivoting mechanism will enable the user to selectively compress the coil spring 67 a specific distance which, in turn, imparts a specific pulling load on the reciprocating sleeve 60 which is converted to a rotational torque about the jaw pivot pin 103. As a
15 result, a specific closure force can be transmitted to the opposing jaw members 110 and 120.

Figs. 37 and 38 show the initial actuation of handle 40 towards fixed handle 50 which causes the free end 95 of flange 90 to move generally proximally and upwardly along entrance pathway 51. During movement of the
20 flange 90 along the entrance and exit pathways 51 and 58, respectively, the t-shaped end 95 rides along track 192 between the two triangular members 57. Once the desired position for the sealing site is determined and the jaw members 110 and 120 are properly positioned, handle 40 may be compressed fully such that the t-shaped end 95 of flange 90 clears a predefined rail edge
25 193 located atop the triangular-shaped members 57. Once end 95 clears edge 193, releasing movement of the handle 40 and flange 90 is redirected into a catch basin 194 located at the proximal end of the triangular member 57. More particularly, upon a slight reduction in the closing pressure of handle 40 against handle 50, the handle 40 returns slightly distally towards entrance
30 pathway 51 but is re-directed towards exit pathway 58. At this point, the release or return pressure between the handles 40 and 50 which is attributable and directly proportional to the release pressure associated with the compression of the drive assembly 150 causes the end 95 of flange 90 to

settle or lock within catch basin 194. Handle 40 is now secured in position within fixed handle 50 which, in turn, locks the jaw members 110 and 120 in a closed position against the tissue 420.

As mentioned above, the jaw members 110 and 120 may be opened,
5 closed and rotated to manipulate tissue 420 until sealing is desired. This enables the user to position and re-position the forceps 10 prior to activation and sealing. As illustrated in Fig. 4, the end effector assembly 100 is rotatable about longitudinal axis "A" through rotation of the rotating assembly 80. As explained in more detail below, it is envisioned that the unique feed path of the
10 cable lead 311 through the rotating assembly 80, along shaft 12 and, ultimately, to the jaw member 110 enables the user to rotate the end effector assembly 100 about 180 degrees in both the clockwise and counterclockwise direction without tangling or causing undue strain on cable lead 311. Cable lead 310c is fused or clipped to the proximal end of tube 160 and is generally
15 unaffected by rotation of the jaw members 110 and 120. As can be appreciated, this facilitates the grasping and manipulation of tissue 420.

Again as best shown in Figs. 13 and 14, trigger assembly 70 mounts atop movable handle 40 and cooperates with the knife assembly 140 to selectively translate knife 185 through a tissue seal 450. More particularly, the
20 trigger assembly 70 includes a finger actuator 71 and a U-shaped upwardly-extending flange 74 having legs 74a and 74b. A pivot pin 73 mounts the trigger assembly 70 between housing halves 20a and 20b for selective rotation thereof. A pair of safety tabs 76a and 76b are disposed atop finger actuator 71 and are dimensioned to abut the locking flange 44 on handle 40 when the
25 handle 40 is disposed in a non-actuated position, i.e., the jaw members 110 and 120 are opened.

As best seen in Fig. 14, the legs 74a and 74b of the U-shaped flange 74 each include a respective slot 77a and 77b defined therein which are each dimensioned to receive a free end of an elongated drive bar 75. Drive bar 75,
30 in turn, is dimensioned to sit within a drive slot 147 which is part of the knife assembly 140 explained in detail below. The trigger assembly 70 is mounted atop the donut-like drive ring 141 of the knife assembly 140. Proximal activation of the finger actuator 71 rotates the trigger assembly 70 about pivot

pin 73 which, in turn, forces the drive bar 75 distally, which, as explained in more detail below, ultimately extends the knife 185 through the tissue 420. A spring 350 biases the knife assembly 70 in a retracted position such that after severing tissue 420 the knife 185 and the knife assembly 70 are automatically
5 returned to a pre-firing position.

As mentioned above, the locking flange 44 abuts tabs 76a and 76b when the handle 40 is disposed in a non-actuated position. When the handle 40 is actuated and flange 90 is fully reciprocated within channel 51 of the fixed handle 50, the locking flange 44 moves proximally allowing activation of the
10 trigger assembly 70 (See Figs. 37 and 44).

Drive assembly 150 includes reciprocating sleeve 60, drive housing 158, spring 67, drive ring 159, drive stop 155 and guide sleeve 157 which all cooperate to form the drive assembly 150. More particularly and as best shown in Figs. 28 and 29, the reciprocating sleeve 60 includes a distal end 65
15 which as mentioned above has an aperture 62 formed therein for actuating the detent 117 of jaw member 110. The distal end 65 preferably includes a scoop-like support member 69 for supporting the proximal end of the fixed jaw member 120 therein. The proximal end 61 of the reciprocating sleeve 60 includes a slot 68 defined therein which is dimensioned to slidably support the
20 knife assembly 70 for longitudinal reciprocation thereof to sever tissue 420. The slot 68 also permits retraction of the reciprocating sleeve 60 over the knife assembly 140 during the closing of jaw member 110 relative to jaw member 120.

The proximal end 61 of the reciprocating sleeve 60 is positioned within
25 an aperture 151 in drive housing 158 to permit selective reciprocation thereof upon actuation of the movable handle 40. The spring 67 is assembled atop the drive housing 158 between a rear stop 156 of the drive housing 158 and a forward stop 154 of the drive ring 159 such that movement of the forward stop 154 compresses the spring 67 against the rear stop 156 which, in turn,
30 reciprocates the drive sleeve 60. As a result thereof, the jaw members 110 and 120 and the movable handle 40 are biased by spring 67 in an open configuration. The drive stop 155 is fixedly positioned atop the drive housing 158 and biases the upper flanges 45a and 45b of the movable handle 40 when

actuated such that the driving flange 47 forces the stop 154 of the drive ring 159 proximally against the force of the spring 67. The spring 67, in turn, forces the rear stop 156 proximally to reciprocate the sleeve 60 (See Fig. 40). Preferably, the rotating assembly 80 is located proximate the driving flange 47
5 to facilitate rotation of the end effector assembly 100. The guide sleeve 157 mates with the proximal end 61 of the reciprocating sleeve 60 and affixes to the drive housing 158. The assembled drive assembly 150 is shown best in Fig. 20.

As best shown in Figs. 18 and 21-24, the knife assembly 140 includes
10 an elongated rod 182 having a bifurcated distal end comprising prongs 182a and 182b which cooperate to receive a knife bar 184 therein. The knife assembly 180 also includes a proximal end 183 which is keyed to facilitate insertion into tube 160 of the rotating assembly 80. A knife wheel 148 is secured to the knife bar 182 by a pin 143. More particularly, the elongated
15 knife rod 182 includes apertures 181a and 181b which are dimensioned to receive and secure the knife wheel 148 to the knife rod 182 such that longitudinal reciprocation of the knife wheel 148, in turn, moves the elongated knife rod 182 to sever tissue 420.

The knife wheel 148 is preferably donut-like and includes rings 141a and
20 141b which define a drive slot 147 designed to receive the drive bar 75 of the trigger assembly 70 such that proximal actuation of the trigger assembly 70 forces the drive bar 75 and the knife wheel 148 distally. It is envisioned that aperture 181a may be used for a particular trigger assembly 70 configuration and aperture 181b may be used for a different trigger assembly 70
25 configuration. As such, pin 143 is designed for attachment through either aperture 181a or 181b to mount the knife wheel 148 (See Fig. 24). Knife wheel 148 also includes a series of radial flanges 142a and 142b which are dimensioned to slide along both channel 163 of tube 160 and slot 68 of the reciprocating sleeve 60 (See Fig. 15).

30 As mentioned above, the knife rod 182 is dimensioned to mount the knife bar 184 between prongs 182a and 182b preferably in friction-fit engagement. The knife bar 184 includes a series of steps 186a, 186b and 186c which reduce the profile of the knife bar 184 towards the distal end

thereof. The distal end of the knife bar 184 includes a knife support 188 which is dimensioned to retain knife blade 185. The end of the knife support preferably includes a chamfered edge 188a. It is envisioned that the knife blade 185 may be welded to the knife support 188 or secured in any manner
5 known in the trade.

As best shown in the exploded view of the Figs. 14 and 30-32, the electrical leads 310a, 310b, 310c and 311 are fed through the housing 20 by electro-surgical cable 310. More particularly, the electro-surgical cable 310 is fed into the bottom of the housing 20 through fixed handle 50. Lead 310c
10 extends directly from cable 310 into the rotating assembly 80 and connects (via a fused clip or spring clip or the like) to tube 60 to conduct the second electrical potential to fixed jaw member 120. Leads 310a and 310b extend from cable 310 and connect to the hand switch or joy-stick-like toggle switch 200.

Switch 200 includes an ergonomically dimensioned toggle plate 205 having a pair of wings 207a and 207b which preferably conform to the outer shape of housing 20 (once assembled). It is envisioned that the switch 200 permits the user to selectively activate the forceps 10 in a variety of different orientations, i.e., multi-oriented activation. As can be appreciated, this
20 simplifies activation. A pair of prongs 204a and 204b extend distally and mate with a corresponding pair of mechanical interfaces 21a and 21b disposed within housing 20 (See Fig. 32). Prongs 204a and 204b preferably snap-fit to the housing 20 during assembly. Toggle plate 205 also includes a switch interface 203 which mates with a switch button 202 which, in turn, connects to
25 electrical interface 201. The electrical leads 310a and 310b are electrically connected to electrical interface 201. When the toggle plate 205 is depressed, trigger lead 311 carries the first electrical potential to jaw member 110. More particularly, lead 311 extends from interface 201 through a plurality of slots 84a, 84b and 84c of the rotating assembly 80 (See Figs. 25 and 30) and along
30 the upper portion of tube 160 and eventually connects to the movable jaw member 110 as described above (See Figs. 32, 34 and 35).

When the switch 200 is depressed, electro-surgical energy is transferred through leads 311 and 310c to jaw members 110 and 120, respectively. It is

envisioned that a safety switch or circuit (not shown) may be employed such that the switch cannot fire unless the jaw members 110 and 120 are closed and/or unless the jaw members 110 and 120 have tissue 420 held therebetween. In the latter instance, a sensor (not shown) may be employed to
5 determine if tissue 420 is held therebetween. In addition, other sensor mechanisms may be employed which determine pre-surgical, concurrent surgical (i.e., during surgery) and/or post surgical conditions. The sensor mechanisms may also be utilized with a closed-loop feedback system coupled to the electrosurgical generator to regulate the electrosurgical energy based
10 upon one or more pre-surgical, concurrent surgical or post surgical conditions. Various sensor mechanisms and feedback systems are described in commonly-owned, co-pending U.S. Patent Application Serial No. 10/427,832 entitled "METHOD AND SYSTEM FOR CONTROLLING OUTPUT OF RF MEDICAL GENERATOR" filed on May 1, 2003 the entire contents of which are
15 hereby incorporated by reference herein.

Preferably, the jaw members 110 and 120 are electrically isolated from one another such that electrosurgical energy can be effectively transferred through the tissue 420 to form seal 450. For example and as best illustrated in Figs. 32, 34 and 35, each jaw member, e.g., 110, includes a uniquely-
20 designed electrosurgical cable path disposed therethrough which transmits electrosurgical energy to the electrically conductive sealing surface 112. It is envisioned that jaw member 110 may include one or more cable guides or crimp-like electrical connectors to direct cable lead 311 towards electrically conductive sealing surface 112. Preferably, cable lead 311 is held loosely but
25 securely along the cable path to permit rotation of the jaw member 110 about pivot 103. As can be appreciated, this isolates electrically conductive sealing surface 112 from the remaining operative components of the end effector assembly 100, jaw member 120 and shaft 12. As explained in detail above, the second electrical potential is conducted to jaw member 120 through tube
30 160. The two potentials are isolated from one another by virtue of the insulative sheathing surrounding cable lead 311.

It is contemplated that utilizing a cable feed path for cable lead 311 and by utilizing a conductive tube 160 to carry the first and second electrical

potentials not only electrically isolates each jaw member 110 and 120 but also allows the jaw members 110 and 120 to pivot about pivot pin 103 without unduly straining or possibly tangling cable lead 311. Moreover, it is envisioned that the simplicity of the electrical connections greatly facilitates the manufacturing and assembly process and assures a consistent and tight electrical connection for the transfer of energy through the tissue 420.

As mentioned above, it is envisioned that cable leads 311 and 310c are fed through respective halves 82a and 82b of the rotating assembly 80 in such a manner to allow rotation of the shaft 12 (via rotation of the rotating assembly 80) in the clockwise or counter-clockwise direction without unduly tangling or twisting the cable leads 311 and 310c. More particularly, each cable lead 311 and 310c is fed through a series of conjoining slots 84a, 84b, 84c and 84d located in the two halves 82a and 82b of the rotating assembly 80. Preferably each conjoining pair of slots, e.g., 84a, 84b and 84c, 84d, are large enough to permit rotation of the rotating assembly 80 without unduly straining or tangling the cable leads 311 and 310c. The presently disclosed cable lead feed path is envisioned to allow rotation of the rotation assembly approximately 180 degrees in either direction.

Turning back to Fig. 14 which shows the exploded view of the housing 20, rotating assembly 80, trigger assembly 70, movable handle 40 and fixed handle 50, it is envisioned that all of these various component parts along with the shaft 12 and the end effector assembly 100 are assembled during the manufacturing process to form a partially and/or fully disposable forceps 10. For example and as mentioned above, the shaft 12 and/or end effector assembly 100 may be disposable and, therefore, selectively/releasably engagable with the housing 20 and rotating assembly 80 to form a partially disposable forceps 10 and/or the entire forceps 10 may be disposable after use.

As best seen in Fig. 13, once assembled, spring 67 is poised for compression atop drive housing 158 upon actuation of the movable handle 40. More particularly, movement of the handle 40 about pivot pins 29a and 29b reciprocates the flange 90 into fixed handle 50 and forces drive flange 47

against flange 154 of drive ring 159 to compress spring 67 against the rear stop 156 to reciprocate the sleeve 60 (See Fig. 40).

Preferably, the trigger assembly 70 is initially prevented from firing by the locking flange 44 disposed on movable handle 40 which abuts against the trigger assembly 70 prior to actuation. It is envisioned that the opposing jaw members 110 and 120 may be rotated and partially opened and closed without unlocking the trigger assembly 70 which, as can be appreciated, allows the user to grip and manipulate the tissue 420 without premature activation of the knife assembly 140. As mentioned below, only when the t-shaped end 95 of flange 90 is completely reciprocated within channel 51 of the fixed handle 50 and seated within pre-defined catch basin 194 will the locking flange allow activation of the trigger assembly 70. The operating features and relative movements of these internal working components of the forceps 10 are shown by phantom representation and directional arrows and are best illustrated in Figs. 36-49.

Fig. 36 shows the forceps approximating tissue. As the handle 40 is squeezed and flange 90 is incorporated into channel 54 of fixed handle 50, the drive flange 47, through the mechanical advantage of the over the center pivot pins 29a and 29b is rotated generally proximally to compress spring 67. Simultaneously, the reciprocating sleeve 60 is pulled proximally by the movement of rear ring 156 which, in turn, causes aperture 62 of sleeve 60 to proximally cam detent 117 and close the jaw member 110 relative to jaw member 120 (See Figs. 37-40).

It is envisioned that the mechanical advantage of the over-the-center pivot will enable the user to selectively compress the coil spring 67 a specific distance which, in turn, imparts a specific load on the reciprocating sleeve 60. The reciprocating sleeve's 60 load is converted to a torque about the jaw pivot 103. As a result, a specific closure force can be transmitted to the opposing jaw members 110 and 120. As mentioned above, the jaw members 110 and 120 may be opened, closed and rotated to manipulate tissue 420 until sealing is desired without unlocking the trigger assembly 70. This enables the user to position and re-position the forceps 10 prior to activation and sealing. More

particularly, as illustrated in Fig. 4, the end effector assembly 100 is rotatable about longitudinal axis "A" through rotation of the rotating assembly 80.

Once the desired position for the sealing site is determined and the jaw members 110 and 120 are properly positioned, handle 40 may be compressed fully such that the t-shaped end 95 of flange 90 clears a predefined rail edge 193 located atop the triangular-shaped members 57. Once end 95 clears edge 193, the end is directed into catch basin 194 located within the exit pathway 58. More particularly, upon a slight reduction in the closing pressure of handle 40 against handle 50, the handle 40 returns slightly distally towards entrance pathway 54 but is re-directed towards exit pathway 58 into catch basin 194 (See Fig. 38). At this point, the release or return pressure between the handles 40 and 50 which is attributable and directly proportional to the release pressure associated with the compression of the drive assembly 150 causes the end 95 of flange 90 to settle or lock within catch basin 194. Handle 40 is now secured in position within fixed handle 50 which, in turn, locks the jaw members 110 and 120 in a closed position against the tissue 420.

At this point the jaws members 110 and 120 are fully compressed about the tissue 420 (Fig. 26). Moreover, the forceps 10 is now ready for selective application of electrosurgical energy and subsequent separation of the tissue 420, i.e., as t-shaped end 95 seats within catch basin 194, locking flange 44 moves into a position to permit activation of the trigger assembly 70 (Figs. 44 and 45).

As the t-shaped end 95 of flange 90 becomes seated within catch basin 194, a proportional axial force on the reciprocating sleeve 60 is maintained which, in turn, maintains a compressive force between opposing jaw members 110 and 120 against the tissue 420. It is envisioned that the end effector assembly 100 and/or the jaw members 110 and 120 may be dimensioned to off-load some of the excessive clamping forces to prevent mechanical failure of certain internal operating elements of the end effector 100.

As can be appreciated, the combination of the mechanical advantage of the over-the-center pivot along with the compressive force associated with the compression spring 67 facilitate and assure consistent, uniform and accurate closure pressure about the tissue 420 within the desired working pressure

range of about 3 kg/cm² to about 16 kg/cm² and, preferably, about 7 kg/cm² to about 13 kg/cm². By controlling the intensity, frequency and duration of the electrosurgical energy applied to the tissue 420, the user can either cauterize, coagulate/desiccate, seal and/or simply reduce or slow bleeding. As mentioned above, two mechanical factors play an important role in determining the resulting thickness of the sealed tissue and effectiveness of the seal 450, i.e., the pressure applied between opposing jaw members 110 and 120 and the gap distance "G" between the opposing sealing surfaces 112, 122 of the jaw members 110 and 120 during the sealing process. However, thickness of the resulting tissue seal 450 cannot be adequately controlled by force alone. In other words, too much force and the two jaw members 110 and 120 would touch and possibly short resulting in little energy traveling through the tissue 420 thus resulting in a bad tissue seal 450. Too little force and the seal 450 would be too thick.

Applying the correct force is also important for other reasons: to oppose the walls of the vessel; to reduce the tissue impedance to a low enough value that allows enough current through the tissue 420; and to overcome the forces of expansion during tissue heating in addition to contributing towards creating the required end tissue thickness which is an indication of a good seal 450.

Preferably, the electrically conductive sealing surfaces 112, 122 of the jaw members 110, 120, respectively, are relatively flat to avoid current concentrations at sharp edges and to avoid arcing between high points. In addition and due to the reaction force of the tissue 420 when engaged, jaw members 110 and 120 are preferably manufactured to resist bending. For example, the jaw members 110 and 120 may be tapered along the width thereof which is advantageous for two reasons: 1) the taper will apply constant pressure for a constant tissue thickness at parallel; 2) the thicker proximal portion of the jaw members 110 and 120 will resist bending due to the reaction force of the tissue 420.

As mentioned above, at least one jaw member, e.g., 120, may include a stop member 750 which limits the movement of the two opposing jaw members 110 and 120 relative to one another. Preferably, the stop member 750 extends from the sealing surface 122 a predetermined distance according to

the specific material properties (e.g., compressive strength, thermal expansion, etc.) to yield a consistent and accurate gap distance "G" during sealing (Fig. 41). Preferably, the gap distance between opposing sealing surfaces 112 and 122 during sealing ranges from about 0.001 inches to about 0.006 inches and, more preferably, between about 0.002 and about 0.003 inches. Preferably, the non-conductive stop members 750 are molded onto the jaw members 110 and 120 (e.g., overmolding, injection molding, etc.), stamped onto the jaw members 110 and 120 or deposited (e.g., deposition) onto the jaw members 110 and 120. For example, one technique involves thermally spraying a ceramic material onto the surface of the jaw member 110 and 120 to form the stop members 750. Several thermal spraying techniques are contemplated which involve depositing a broad range of heat resistant and insulative materials on various surfaces to create stop members 750 for controlling the gap distance between electrically conductive surfaces 112 and 122.

As energy is being selectively transferred to the end effector assembly 100, across the jaw members 110 and 120 and through the tissue 420, a tissue seal 450 forms isolating two tissue halves 420a and 420b. At this point and with other known vessel sealing instruments, the user must remove and replace the forceps 10 with a cutting instrument (not shown) to divide the tissue halves 420a and 420b along the tissue seal 450. As can be appreciated, this is both time consuming and tedious and may result in inaccurate tissue division across the tissue seal 450 due to misalignment or misplacement of the cutting instrument along the ideal tissue cutting plane.

As explained in detail above, the present disclosure incorporates knife assembly 140 which, when activated via the trigger assembly 70, progressively and selectively divides the tissue 420 along an ideal tissue plane in precise manner to effectively and reliably divide the tissue 420 into two sealed halves 420a and 420b (See Fig. 46) with a tissue gap 475 therebetween. The knife assembly 140 allows the user to quickly separate the tissue 420 immediately after sealing without substituting a cutting instrument through a cannula or trocar port. As can be appreciated, accurate sealing and dividing of tissue 420 is accomplished with the same forceps 10.

It is envisioned that knife blade 185 may also be coupled to the same or an alternative electrosurgical energy source to facilitate separation of the tissue 420 along the tissue seal 450 (Not shown). Moreover, it is envisioned that the angle of the knife blade tip 185 may be dimensioned to provide more or less aggressive cutting angles depending upon a particular purpose. For example, the knife blade 185 may be positioned at an angle which reduces "tissue wisps" associated with cutting. Moreover, the knife blade 185 may be designed having different blade geometries such as serrated, notched, perforated, hollow, concave, convex etc. depending upon a particular purpose or to achieve a particular result.

Once the tissue 420 is divided into tissue halves 420a and 420b, the jaw members 110 and 120 may be opened by re-grasping the handle 40 as explained below. It is envisioned that the knife assembly 140 generally cuts in a progressive, uni-directional fashion (i.e., distally).

As best shown in Figs. 47-49, re-initiation or re-grasping of the handle 40 again moves t-shaped end 95 of flange 90 generally proximally along exit pathway 58 until end 95 clears a lip 196 disposed atop triangular-shaped members 57 along exit pathway 58. Once lip 196 is sufficiently cleared, handle 40 and flange 90 are fully and freely releasable from handle 50 along exit pathway 58 upon the reduction of grasping/gripping pressure which, in turn, returns the jaw members 110 and 120 to the open, pre-activated position.

From the foregoing and with reference to the various figure drawings, those skilled in the art will appreciate that certain modifications can also be made to the present disclosure without departing from the scope of the same. For example, it may be preferable to add other features to the forceps 10, e.g., an articulating assembly to axially displace the end effector assembly 100 relative to the elongated shaft 12.

It is also contemplated that the forceps 10 (and/or the electrosurgical generator used in connection with the forceps 10) may include a sensor or feedback mechanism (not shown) which automatically selects the appropriate amount of electrosurgical energy to effectively seal the particularly-sized tissue grasped between the jaw members 110 and 120. The sensor or feedback mechanism may also measure the impedance across the tissue during sealing

and provide an indicator (visual and/or audible) that an effective seal has been created between the jaw members 110 and 120. Examples of such sensor systems are described in commonly-owned U.S. Patent Application Serial No. 10/427,832 entitled "METHOD AND SYSTEM FOR CONTROLLING OUTPUT
5 OF RF MEDICAL GENERATOR" filed on May 1, 2003 the entire contents of which are hereby incorporated by reference herein.

Moreover, it is contemplated that the trigger assembly 70 may include other types of recoil mechanism which are designed to accomplish the same purpose, e.g., gas-actuated recoil, electrically-actuated recoil (i.e., solenoid),
10 etc. It is also envisioned that the forceps 10 may be used to cut tissue 420 without sealing. Alternatively, the knife assembly 70 may be coupled to the same or alternate electrosurgical energy source to facilitate cutting of the tissue 420.

Although the figures depict the forceps 10 manipulating an isolated
15 vessel 420, it is contemplated that the forceps 10 may be used with non-isolated vessels as well. Other cutting mechanisms are also contemplated to cut tissue 420 along the ideal tissue plane.

It is envisioned that the outer surface of the end effector assembly 100 may include a nickel-based material, coating, stamping, metal injection molding
20 which is designed to reduce adhesion between the jaw members 110 and 120 with the surrounding tissue during activation and sealing. Moreover, it is also contemplated that the conductive surfaces 112 and 122 of the jaw members 110 and 120 may be manufactured from one (or a combination of one or more) of the following materials: nickel-chrome, chromium nitride, MedCoat 2000
25 manufactured by The Electrolyzing Corporation of OHIO, inconel 600 and tin-nickel. The tissue conductive surfaces 112 and 122 may also be coated with one or more of the above materials to achieve the same result, i.e., a "non-stick surface". As can be appreciated, reducing the amount that the tissue "sticks" during sealing improves the overall efficacy of the instrument.

30 One particular class of materials disclosed herein has demonstrated superior non-stick properties and, in some instances, superior seal quality. For example, nitride coatings which include, but are not limited to: TiN, ZrN, TiAlN, and CrN are preferred materials used for non-stick purposes. CrN has

been found to be particularly useful for non-stick purposes due to its overall surface properties and optimal performance. Other classes of materials have also been found to reducing overall sticking. For example, high nickel/chrome alloys with a Ni/Cr ratio of approximately 5:1 have been found to significantly reduce sticking in bipolar instrumentation. One particularly useful non-stick material in this class is Inconel 600. Bipolar instrumentation having sealing surfaces 112 and 122 made from or coated with Ni200, Ni201 (~100% Ni) also showed improved non-stick performance over typical bipolar stainless steel electrodes.

As can be appreciated, locating the switch 200 on the forceps 10 has many advantages. For example, the switch 200 reduces the amount of electrical cable in the operating room and eliminates the possibility of activating the wrong instrument during a surgical procedure due to "line-of-sight" activation. Moreover, decommissioning the switch 200 when the trigger is actuated eliminates unintentionally activating the device during the cutting process. It is also envisioned that the switch 200 may be disposed on another part of the forceps 10, e.g., the fixed handle 40, rotating assembly 80, housing 20, etc.

While several embodiments of the disclosure have been shown in the drawings, it is not intended that the disclosure be limited thereto, as it is intended that the disclosure be as broad in scope as the art will allow and that the specification be read likewise. Therefore, the above description should not be construed as limiting, but merely as exemplifications of preferred embodiments. Those skilled in the art will envision other modifications within the scope and spirit of the claims appended hereto.

WHAT IS CLAIMED IS:

1. An endoscopic bipolar forceps, comprising:
 - a housing;
 - 5 a shaft affixed to said housing having a movable jaw member and a fixed jaw member at a distal end thereof, said shaft defining a longitudinal axis defined therethrough;
 - a drive assembly for moving said movable jaw member relative to the fixed jaw member from a first position wherein the movable jaw member is disposed in spaced relation relative to the fixed jaw member
 - 10 to a second position wherein the movable jaw member is closer to the fixed jaw member for manipulating tissue;
 - a movable handle being rotatable about a pivot to force a drive flange of said movable handle into mechanical cooperation with said
 - 15 drive assembly to move said jaw members from the open and closed positions, said pivot being located a fixed distance from said longitudinal axis and said drive flange being located generally along said longitudinal axis; and
 - a source of electrosurgical energy connected to each jaw member such that the jaw members are capable of conducting energy
 - 20 through tissue held therebetween to effect a tissue seal.
2. An endoscopic bipolar forceps according to claim 1 further comprising a selectively advanceable knife assembly for cutting tissue in a forward direction
- 25 along the tissue seal.
3. An endoscopic bipolar forceps according to any preceding claim further comprising a rotating assembly for rotating said jaw members about the longitudinal axis defined through said shaft.
- 30
4. An endoscopic bipolar forceps according to any preceding claim further comprising a hand switch disposed within said housing and in electromechanical cooperation with said source of electrosurgical energy, said

hand switch allowing a user to selectively supply bipolar energy to said jaw members to effect a seal.

5. An endoscopic bipolar forceps according to any preceding claim wherein
5 said movable jaw member includes a first electrical potential and said fixed jaw member includes a second electrical potential, wherein said second electrical potential is conducted to said fixed jaw member by a conductive tube.
6. An endoscopic bipolar forceps according to any preceding claim wherein
10 said conductive tube is connected to said rotating assembly.
7. An endoscopic bipolar forceps according to any preceding claim wherein
said drive assembly includes a reciprocating sleeve which, upon activation of
said movable handle, translates to move said movable jaw member relative to
15 said fixed jaw member.
8. An endoscopic bipolar forceps according to any preceding claim
wherein said movable jaw member includes a detent which extends beyond
said fixed jaw member and which is designed for engagement with said
20 reciprocating sleeve such that upon translation of said reciprocating sleeve,
said movable jaw member moves relative to said fixed jaw member.
9. An endoscopic bipolar forceps according to any preceding claim wherein
said drive assembly includes at least one spring.
25
10. An endoscopic bipolar forceps according to any preceding claim wherein
at least one of said jaw members includes a series of stop members disposed
thereon for regulating the distance between said jaw members during sealing.
- 30 11. An endoscopic bipolar forceps, comprising:
a shaft having a movable jaw member and a fixed jaw member at
a distal end thereof;

5 a drive assembly for moving said movable jaw member relative to the fixed jaw member from a first position wherein the movable jaw member is disposed in spaced relation relative to the fixed jaw member to a second position wherein the movable jaw member is closer to the fixed jaw member for manipulating tissue;

a movable handle for actuating said drive assembly to move said movable jaw member;

10 a source of electrical energy connected to each jaw member such that the jaw members are capable of conducting energy through tissue held therebetween to effect a tissue seal;

a selectively advanceable knife assembly for cutting tissue in a forward direction along the tissue seal; and

15 a rotating assembly for selectively rotating said jaw members about said longitudinal axis, said rotating assembly being located proximate to said movable handle.

12. An endoscopic bipolar forceps, comprising:

a shaft having a movable jaw member and a fixed jaw member at a distal end thereof;

20 a drive assembly for moving said movable jaw member relative to the fixed jaw member from a first position wherein the movable jaw member is disposed in spaced relation relative to the fixed jaw member to a second position wherein the movable jaw member is closer to the fixed jaw member for manipulating tissue;

25 a movable handle for actuating said drive assembly to move said movable jaw member;

a source of electrical energy connected to each jaw member such that the jaw members are capable of conducting energy through tissue held therebetween to effect a tissue seal;

30 a selectively advanceable knife assembly for cutting tissue in a forward direction along the tissue seal; and

a stop member disposed on at least one of said jaw members for regulating the distance between jaw members during sealing.

13. A bipolar forceps according to claim 12 further comprising a rotating assembly for rotating said jaw members about a longitudinal axis defined through said shaft.

5

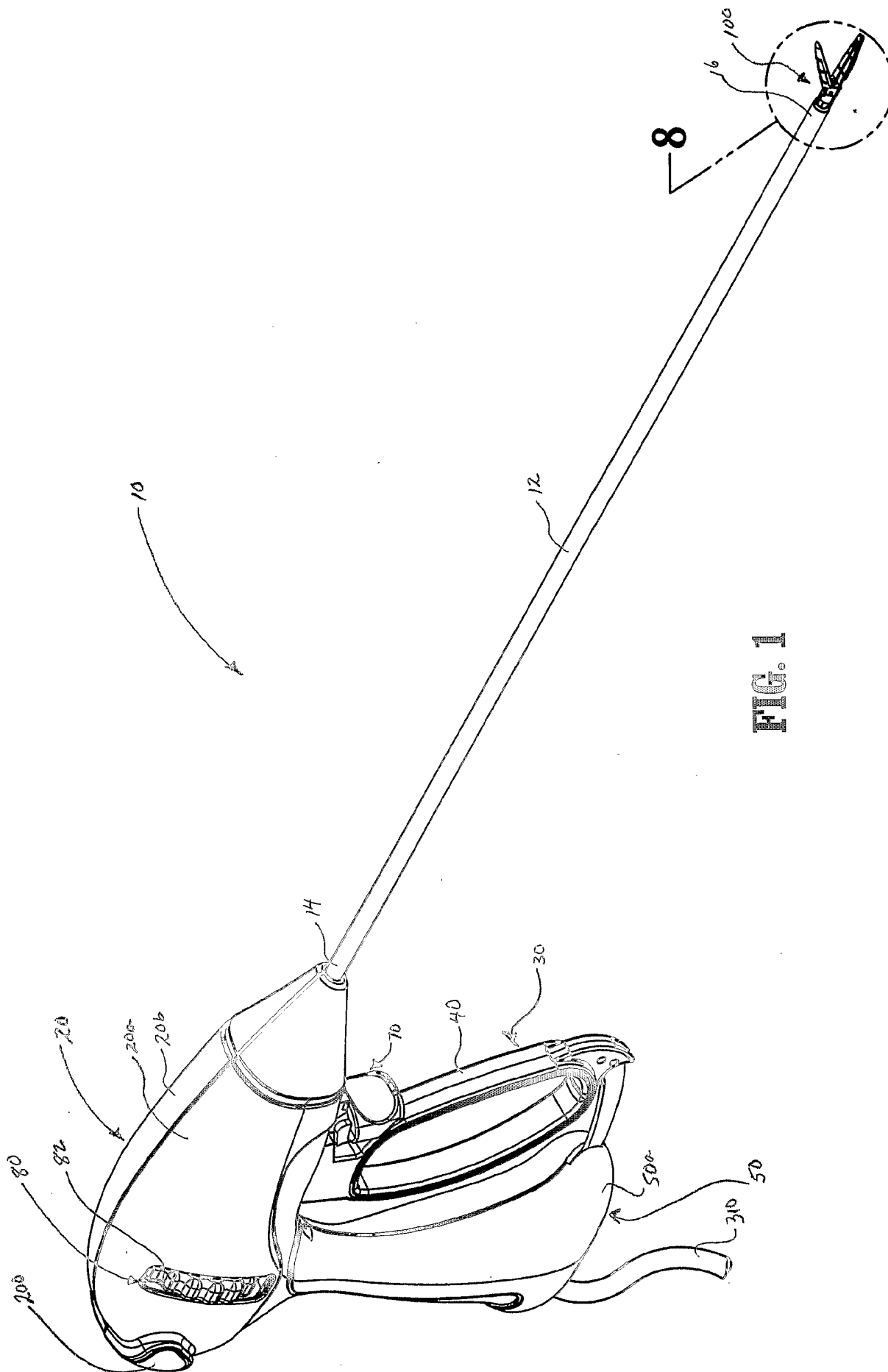

FIG. 1

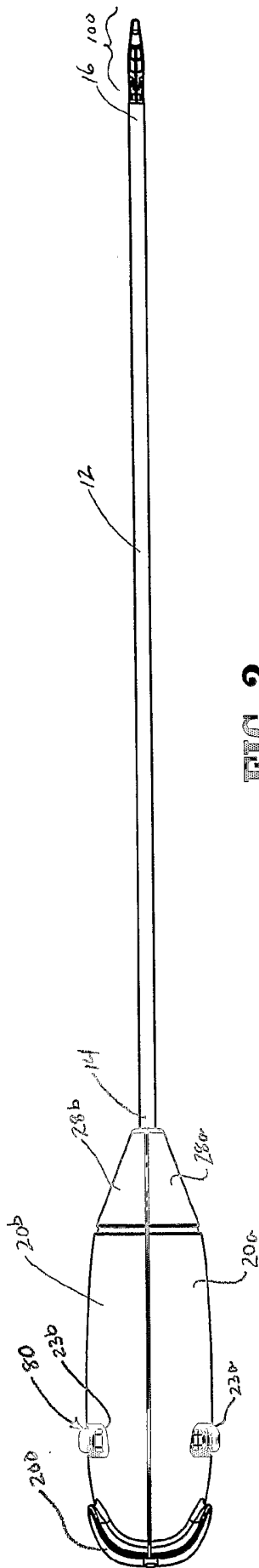

FIG. 2

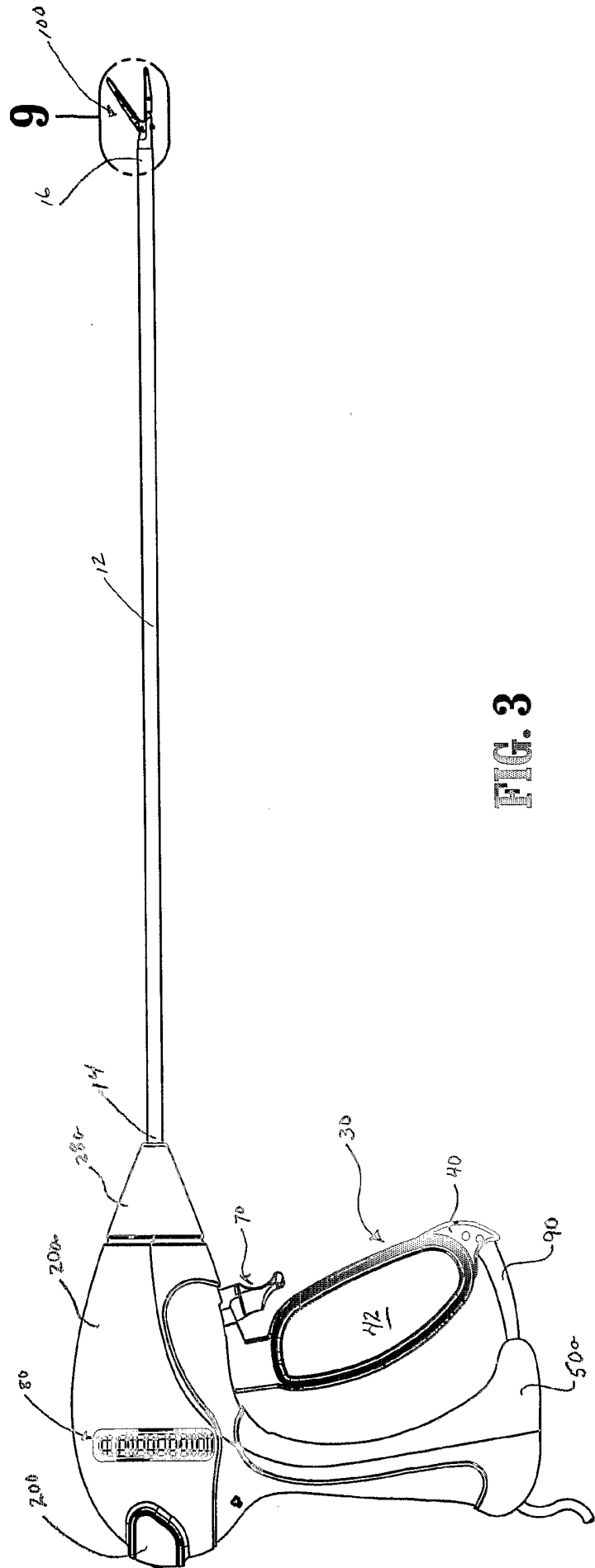

FIG. 3

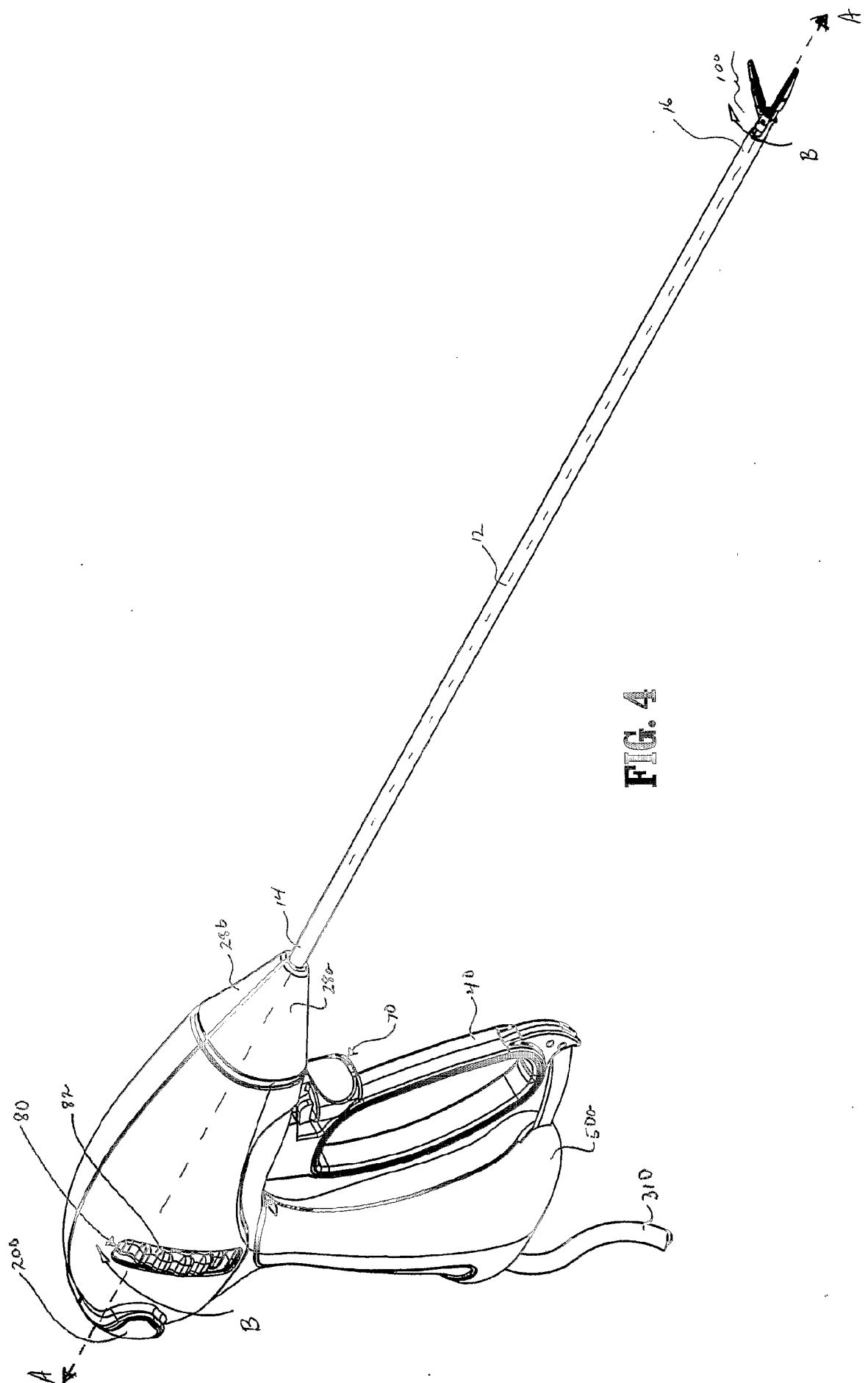

FIG. 4

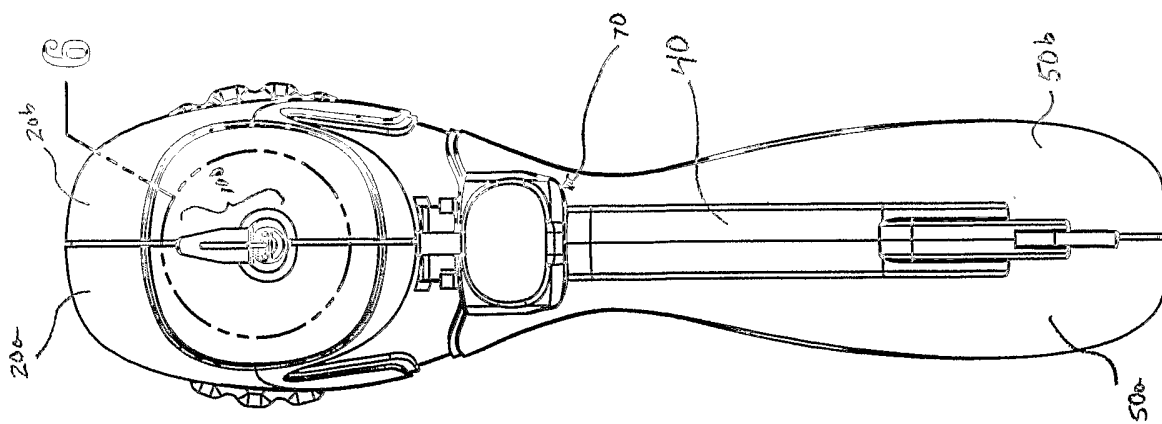

FIG. 5

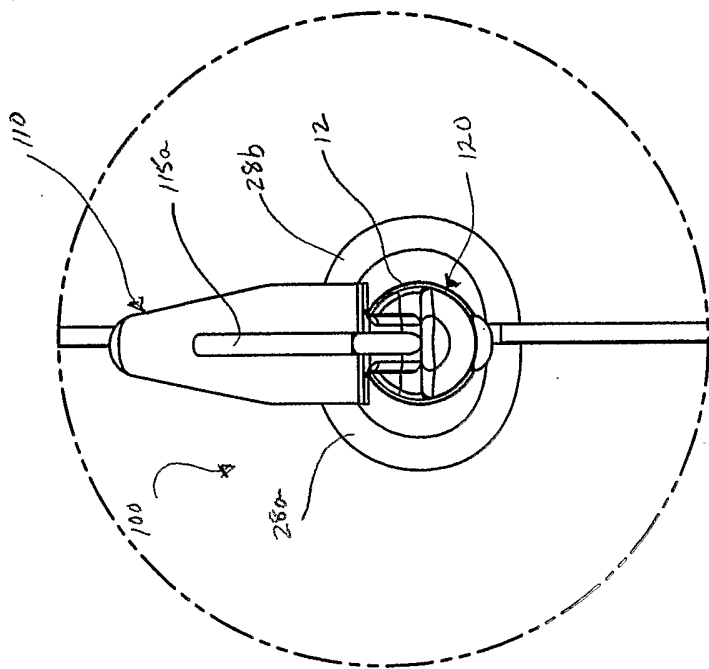

FIG. 6

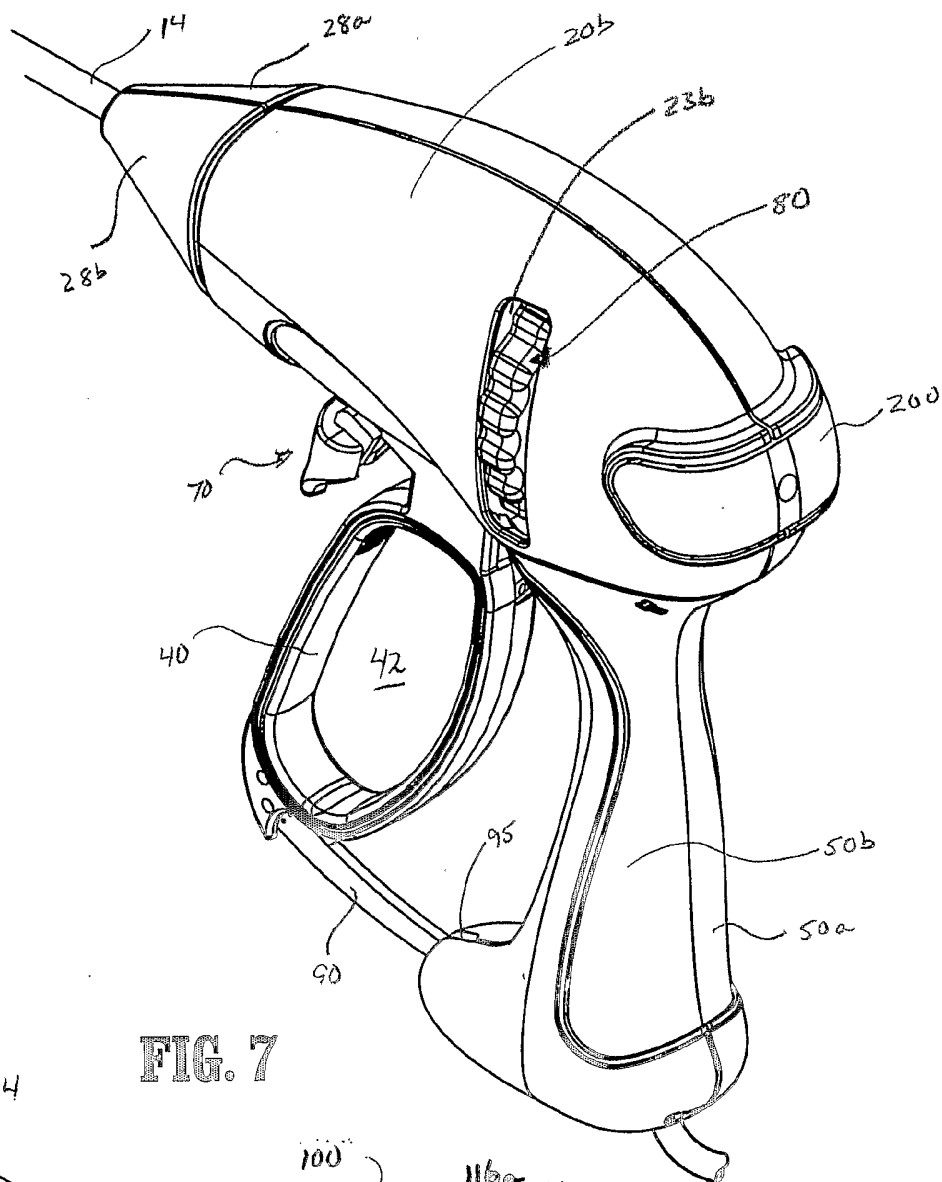

FIG. 7

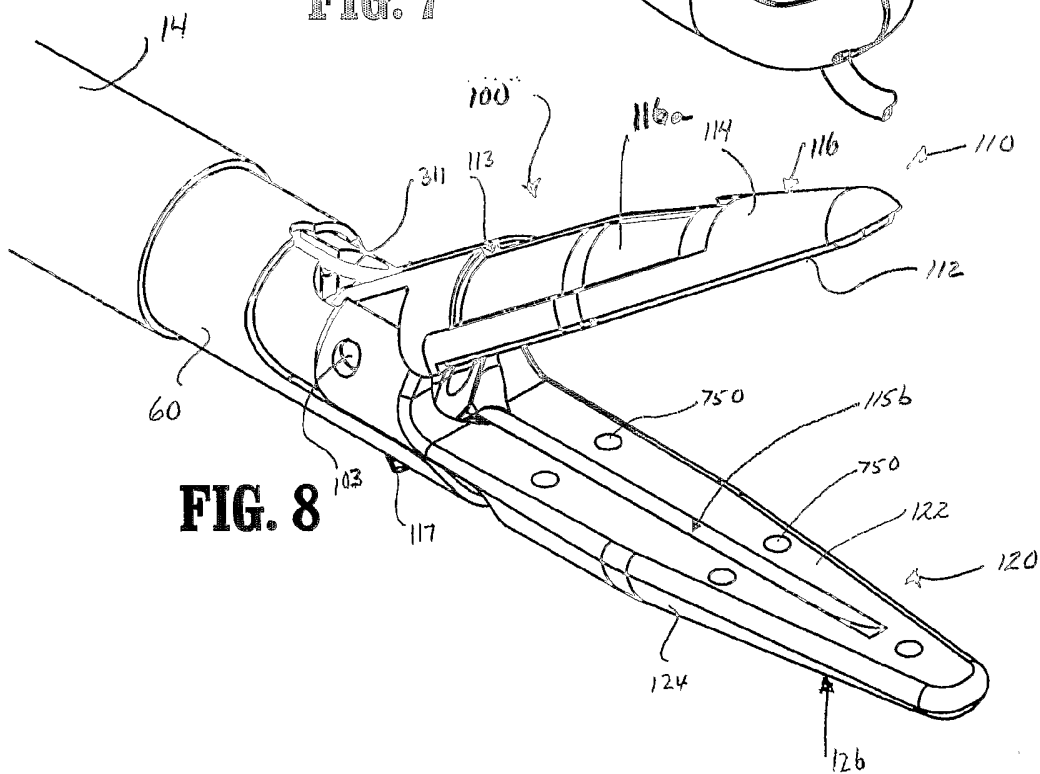

FIG. 8

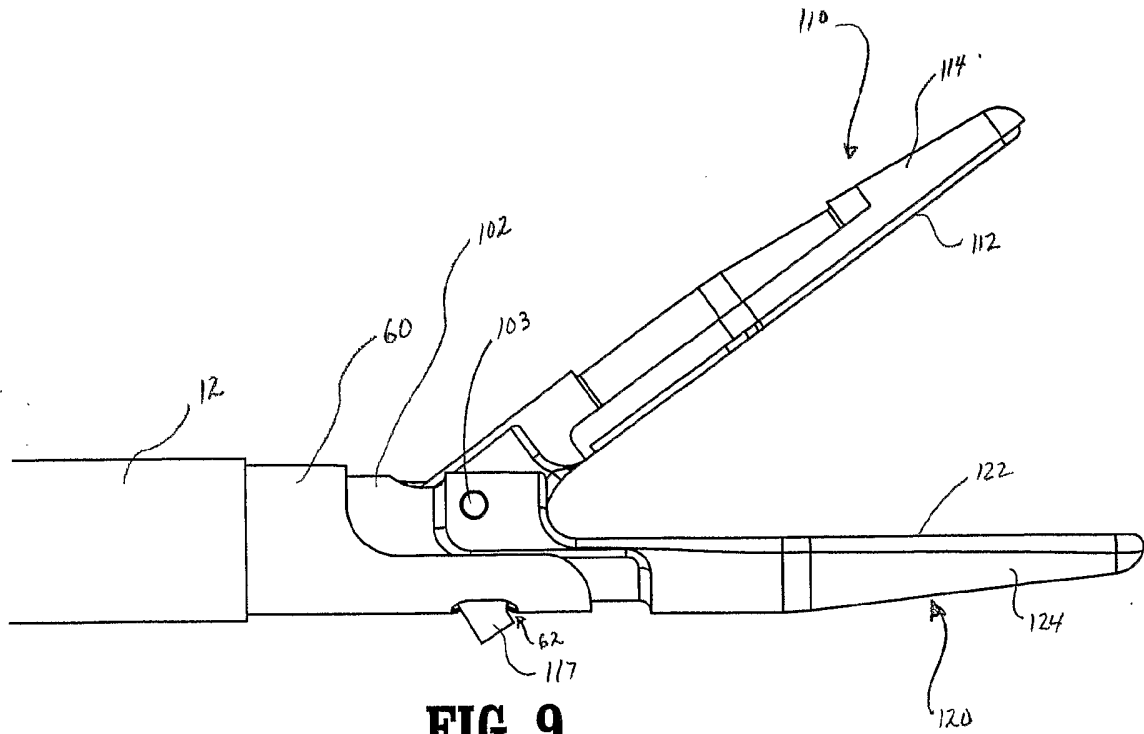

FIG. 9

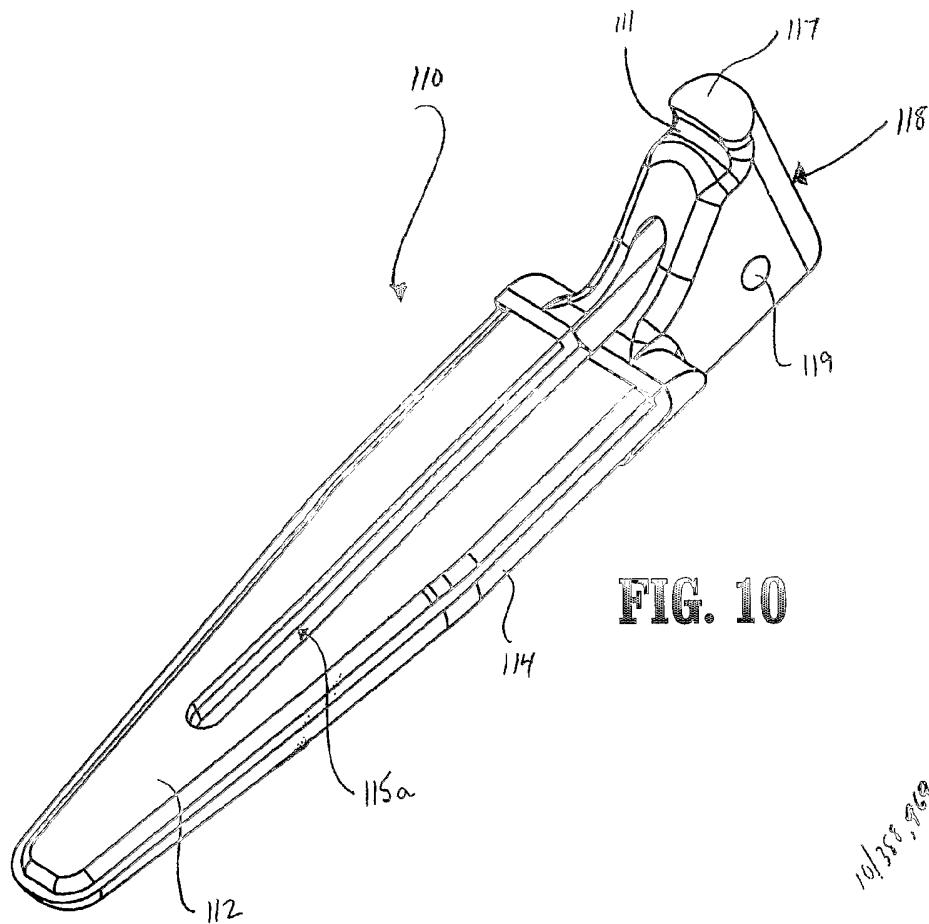

FIG. 10

10,358,969

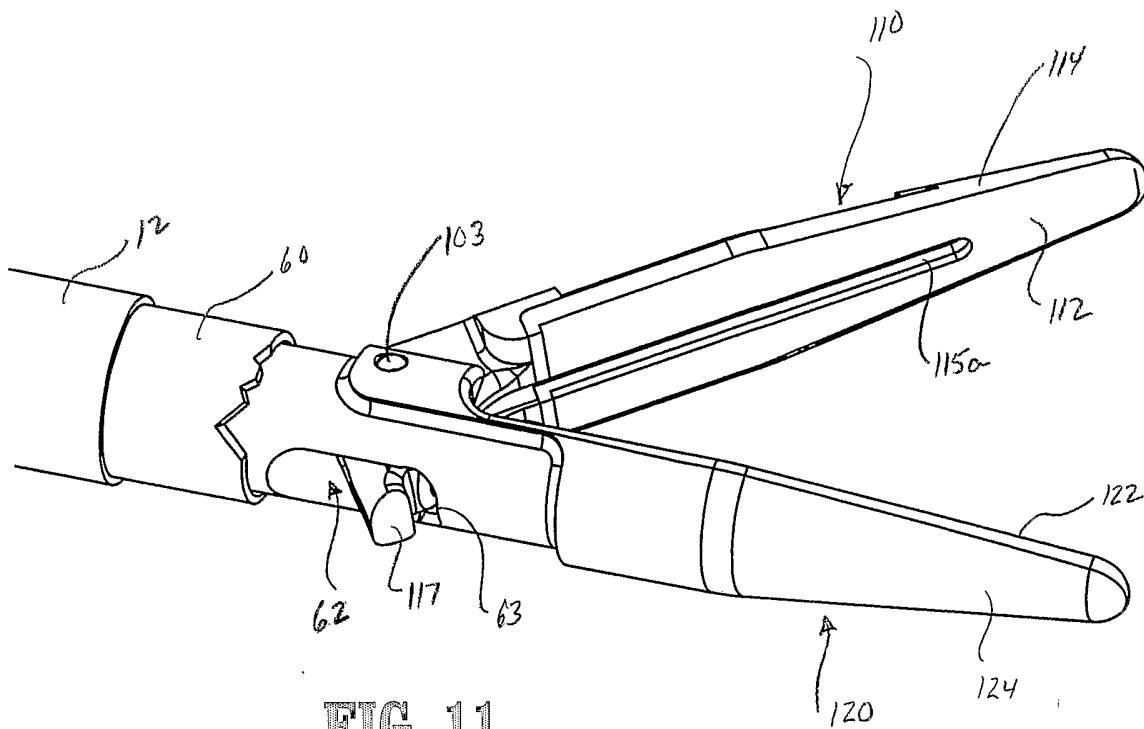

FIG. 11

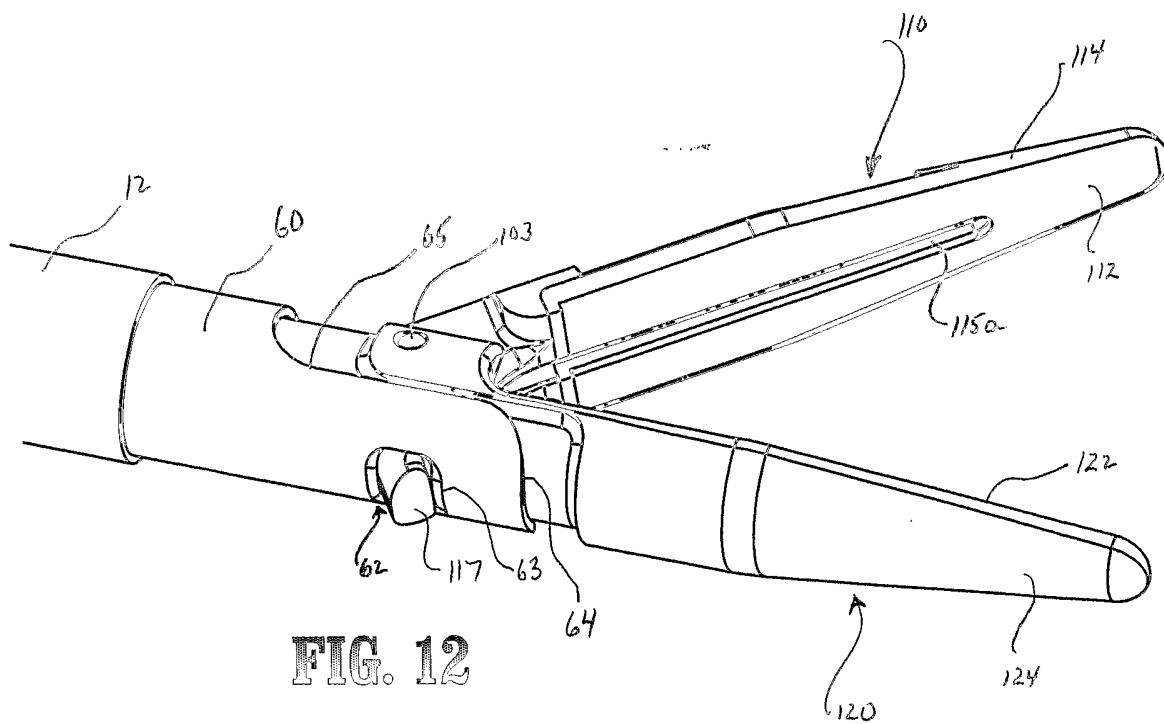

FIG. 12

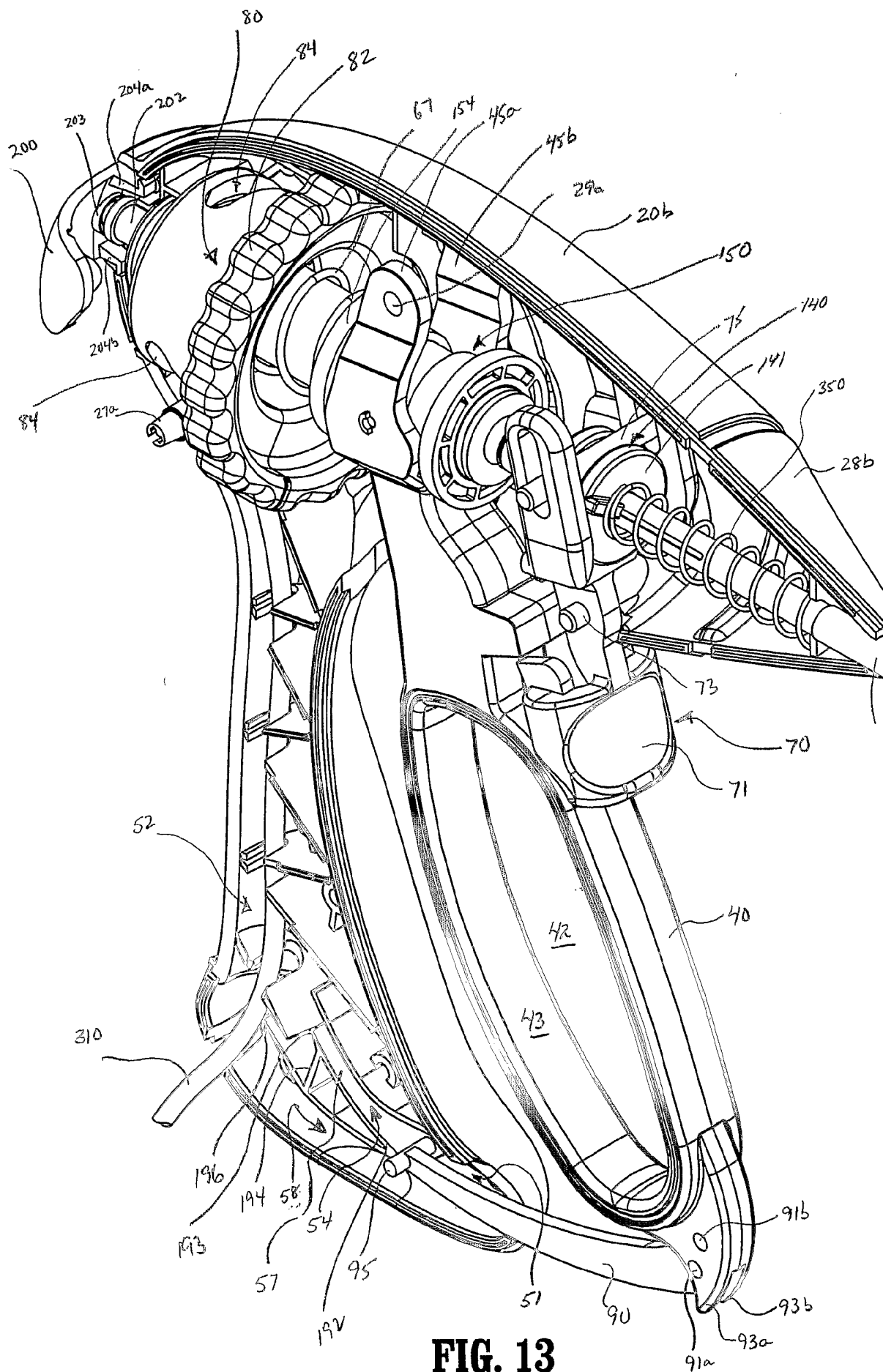

FIG. 13

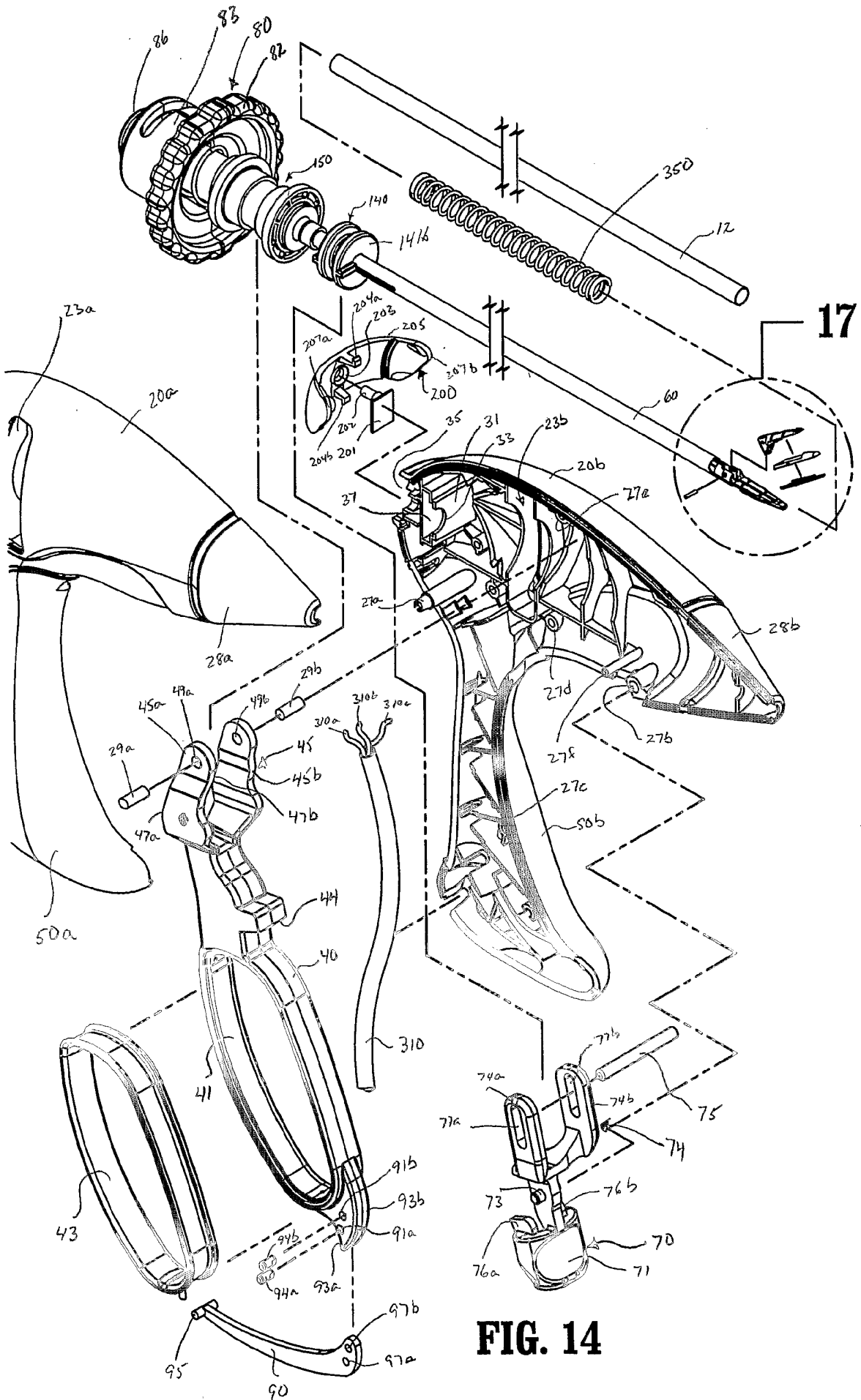

FIG. 14

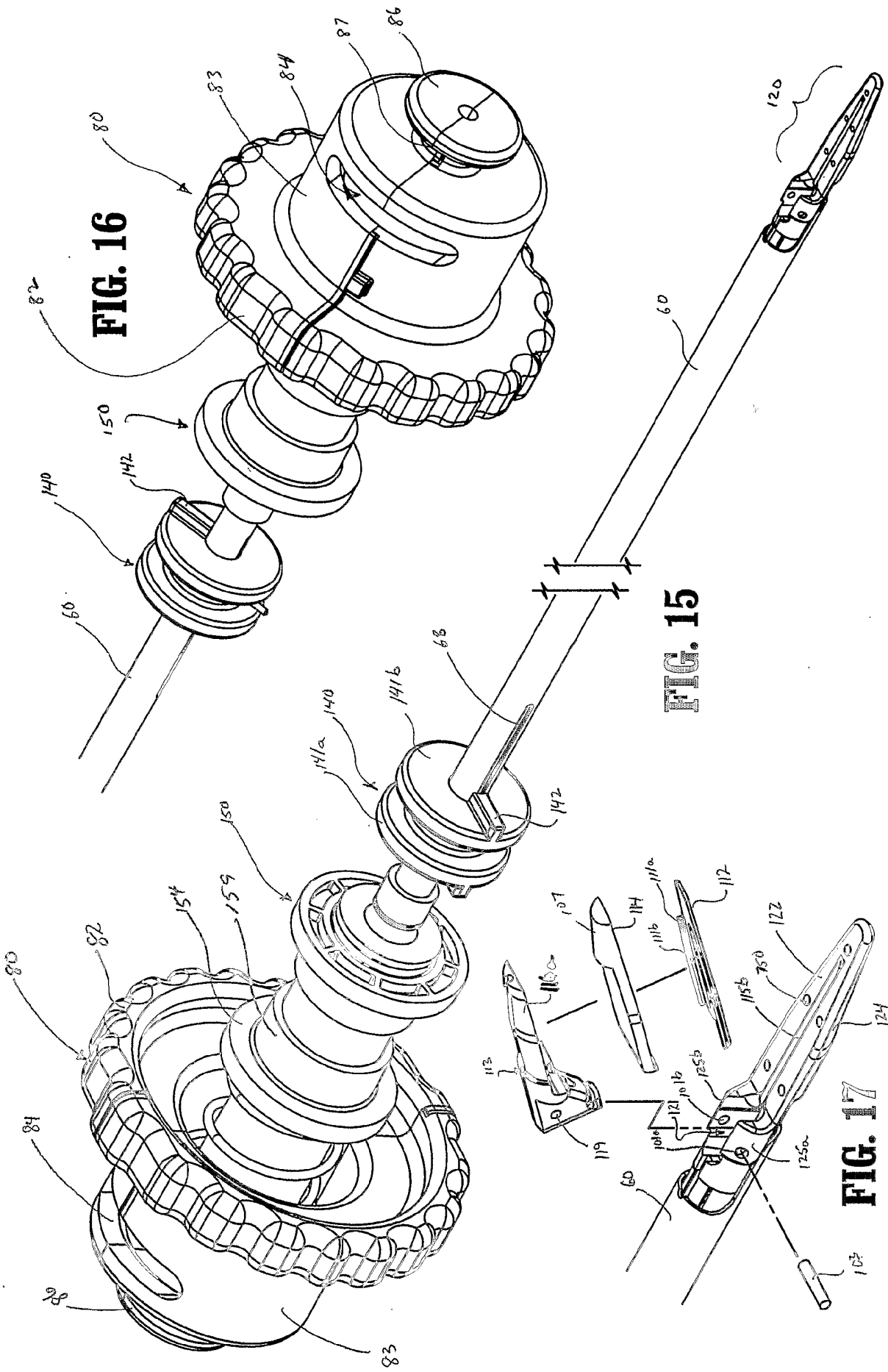
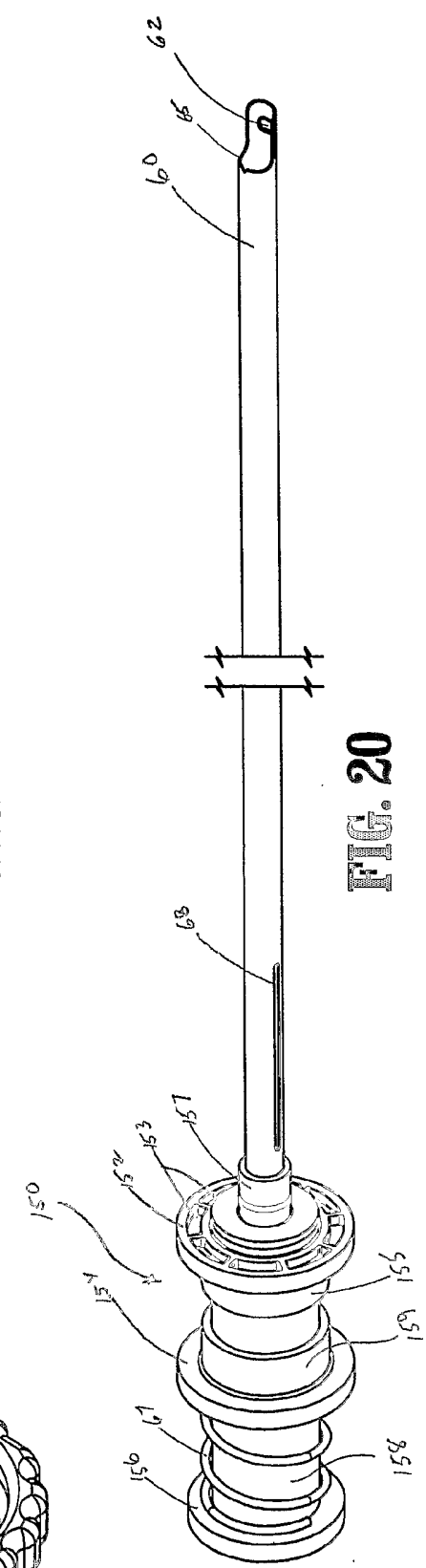
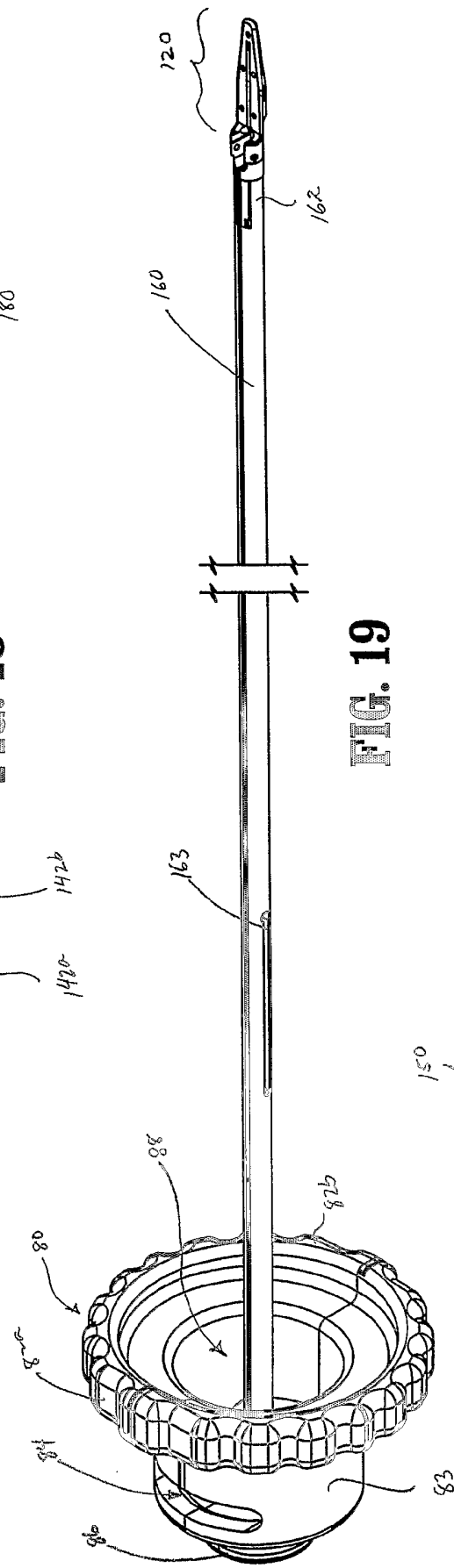
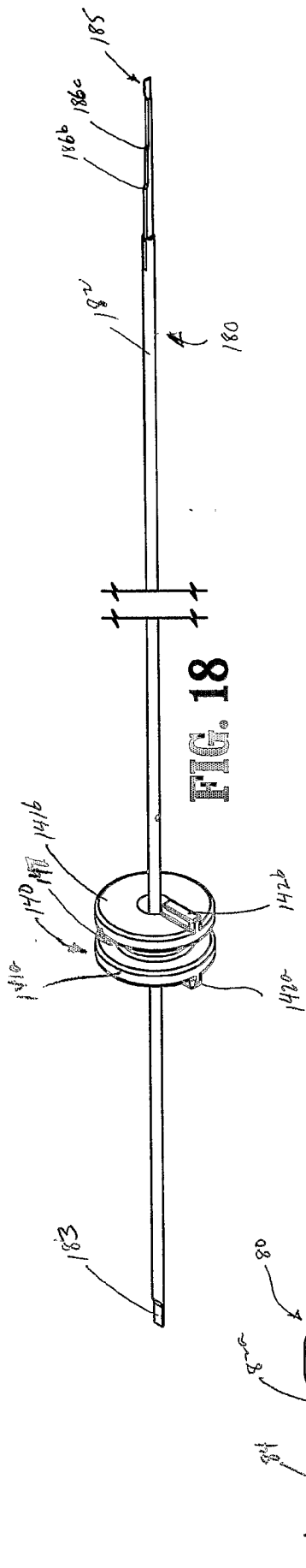

FIG. 16

FIG. 15

FIG. 17



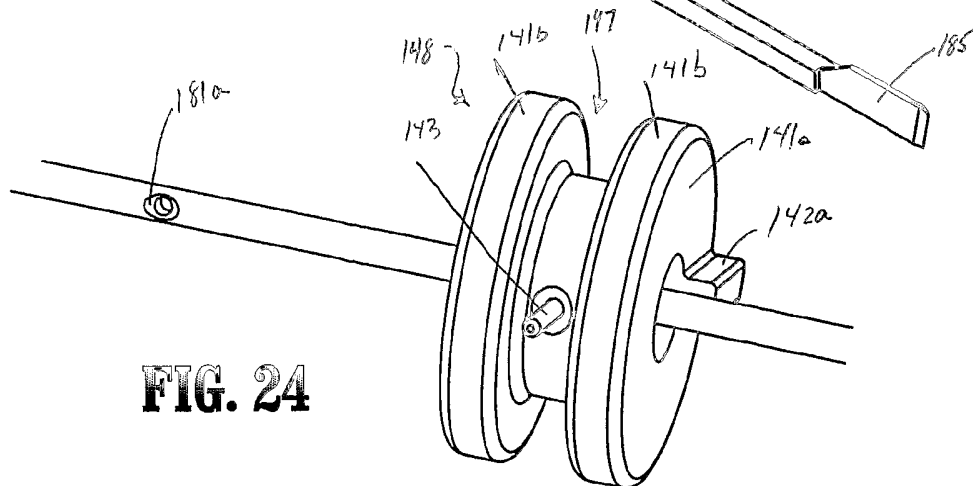
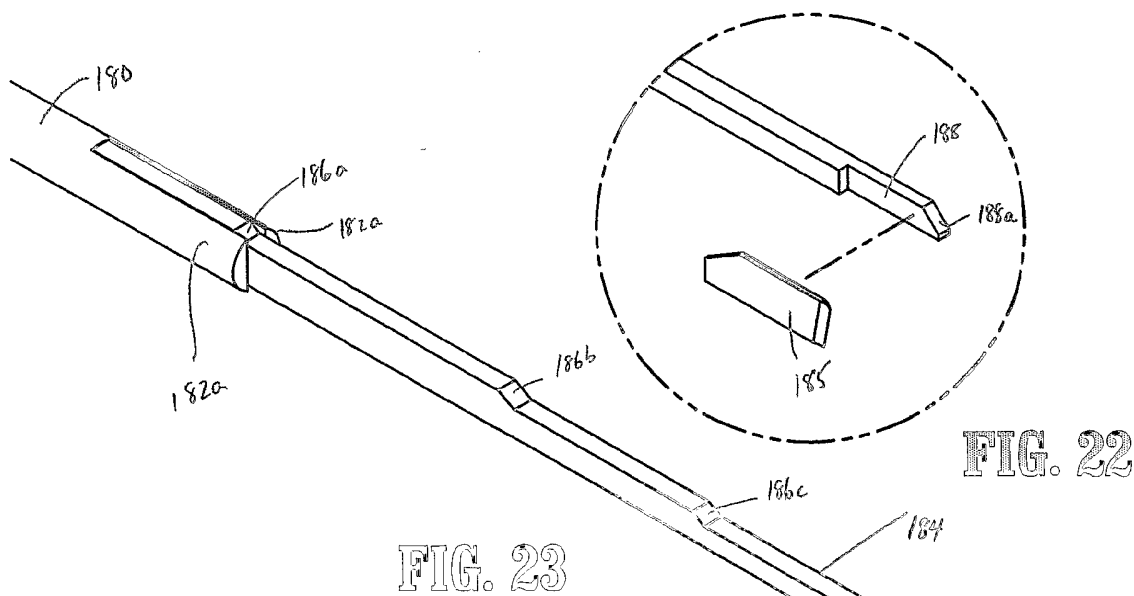
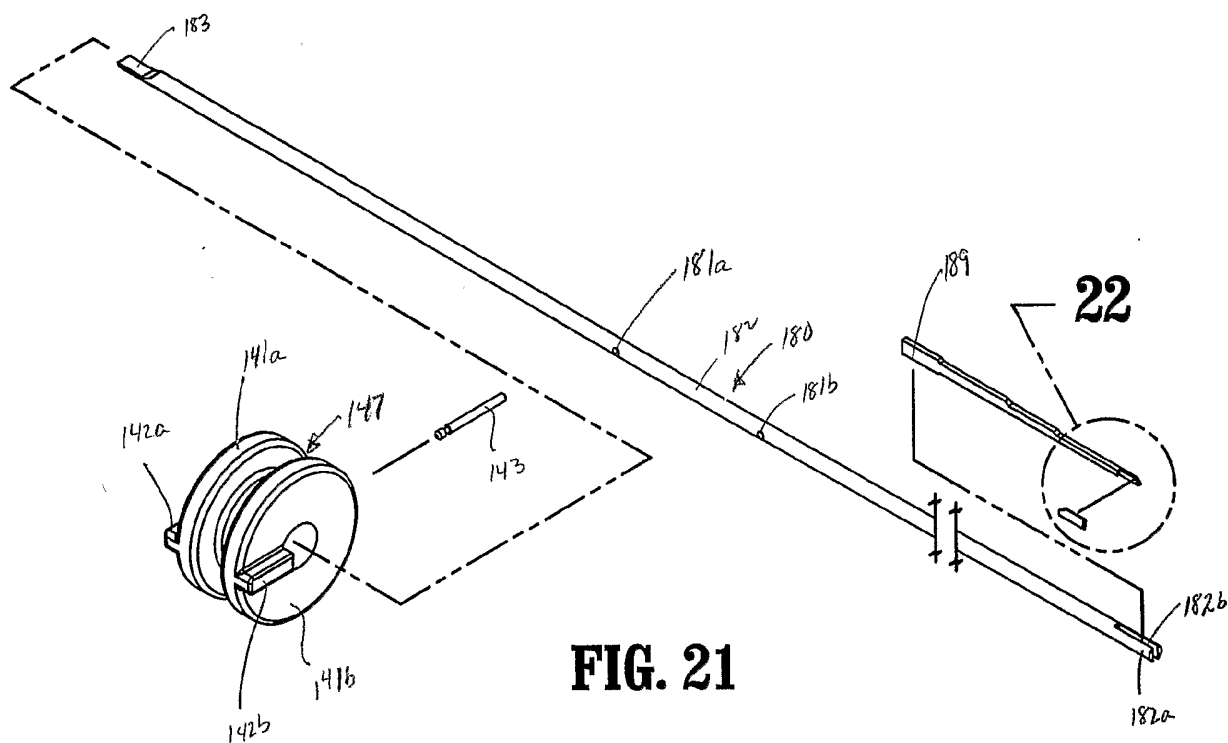
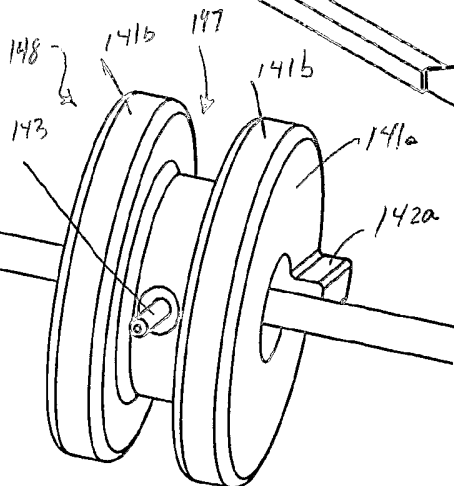
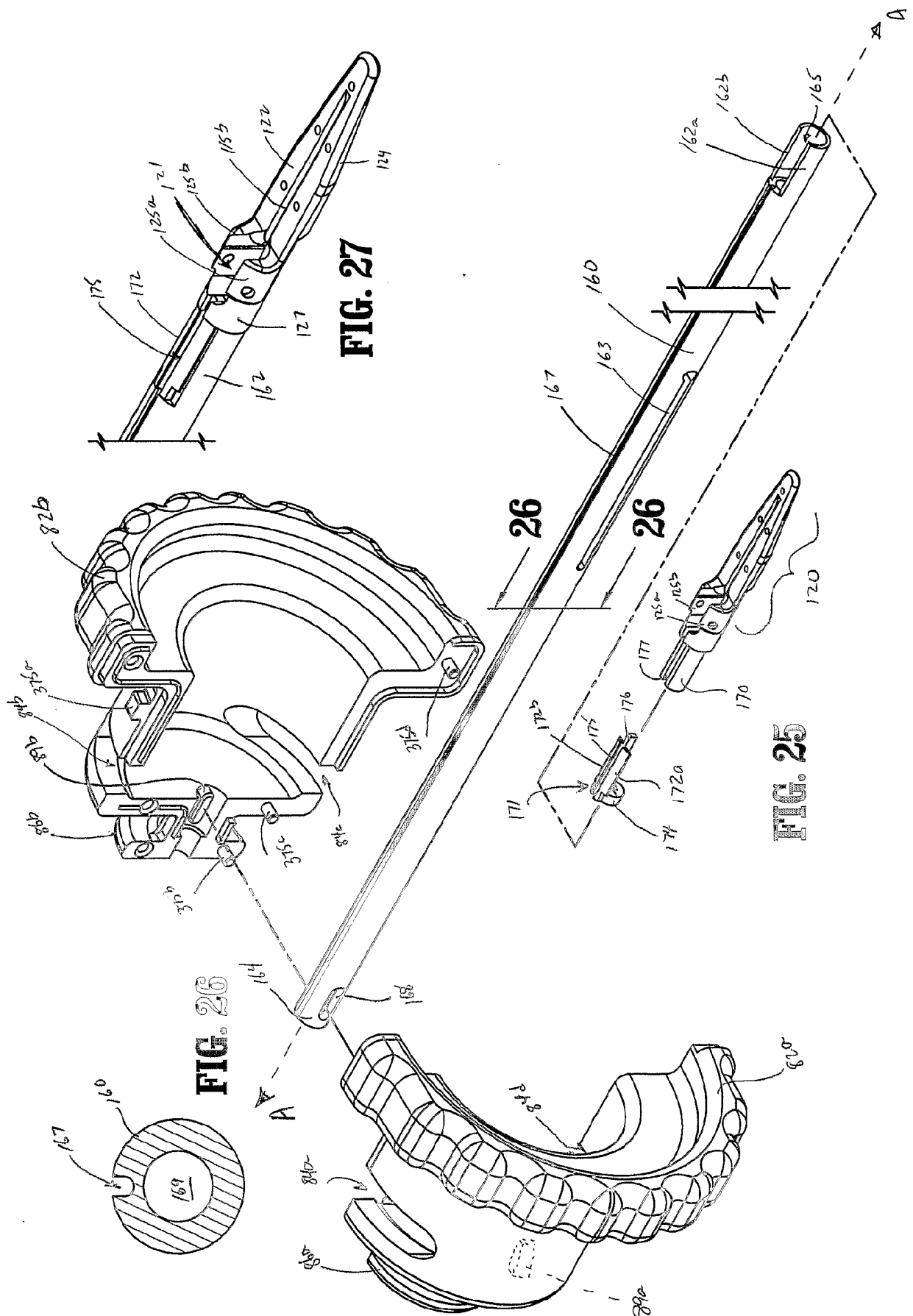

FIG. 24





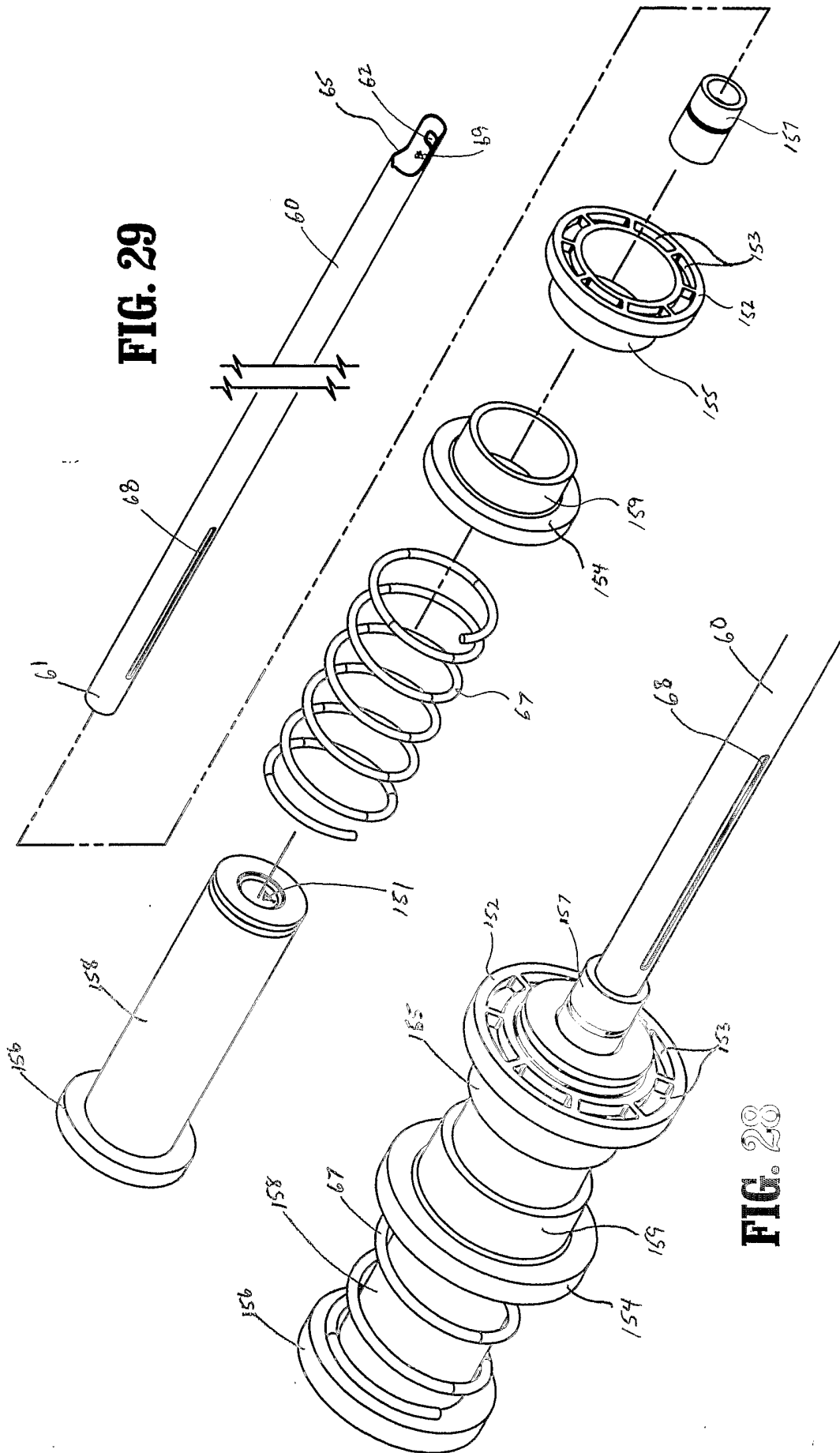

FIG. 29

FIG. 20

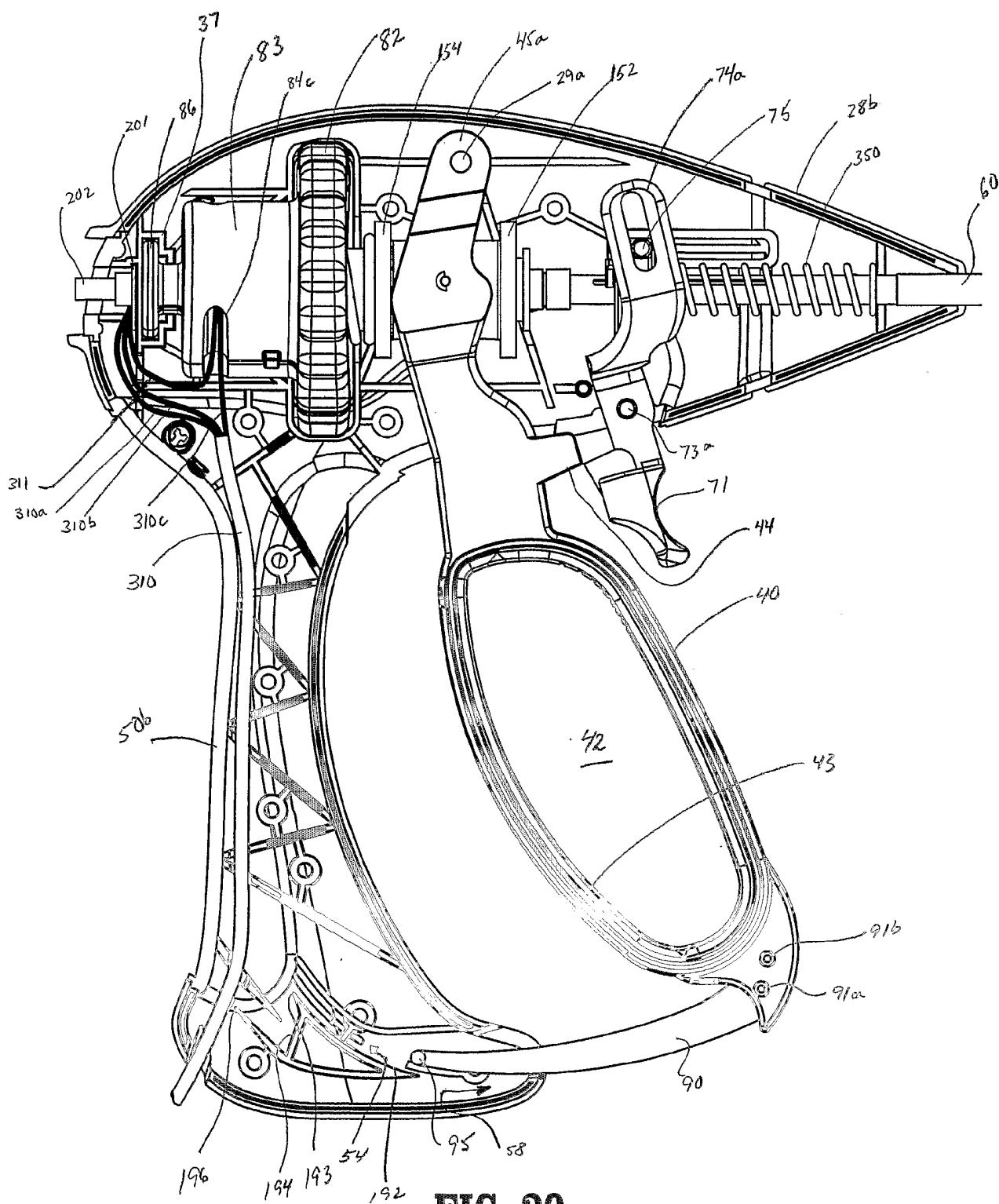

FIG. 30

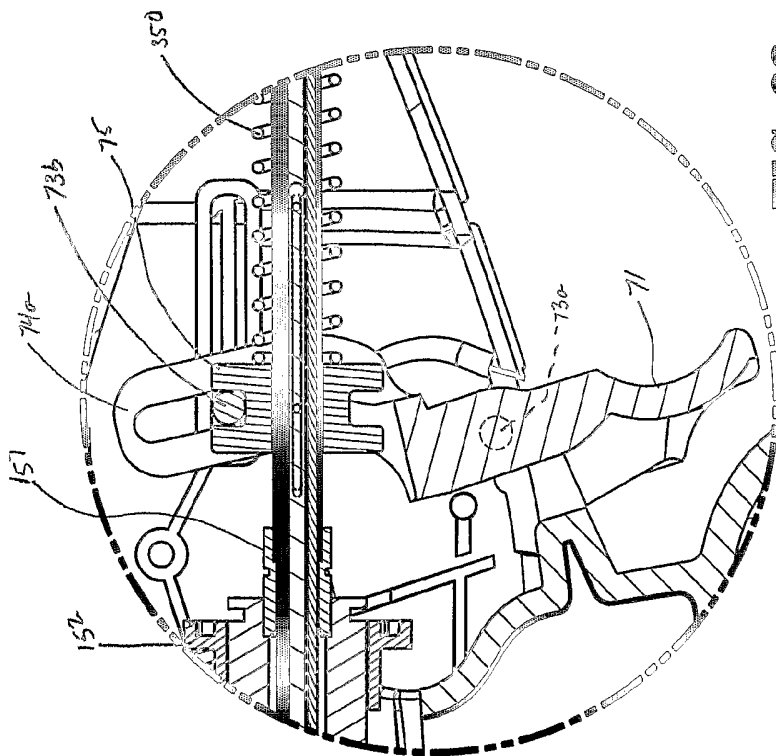

FIG. 33

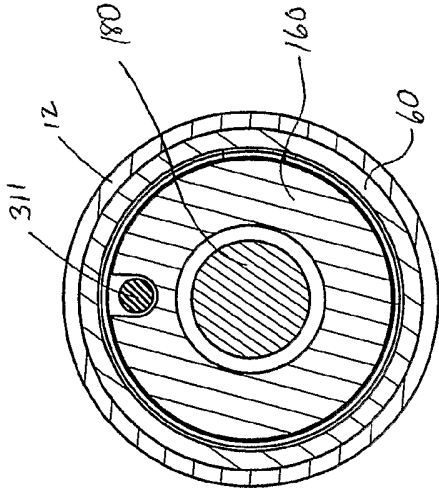

FIG. 34

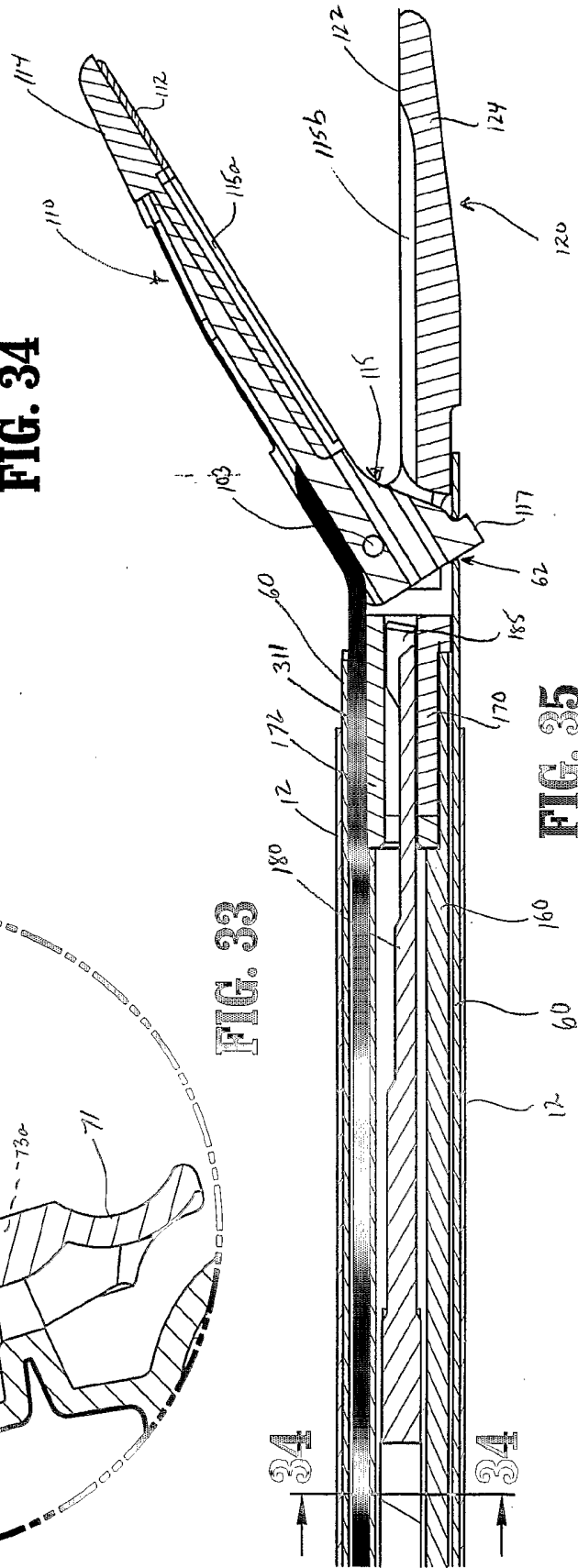

FIG. 35

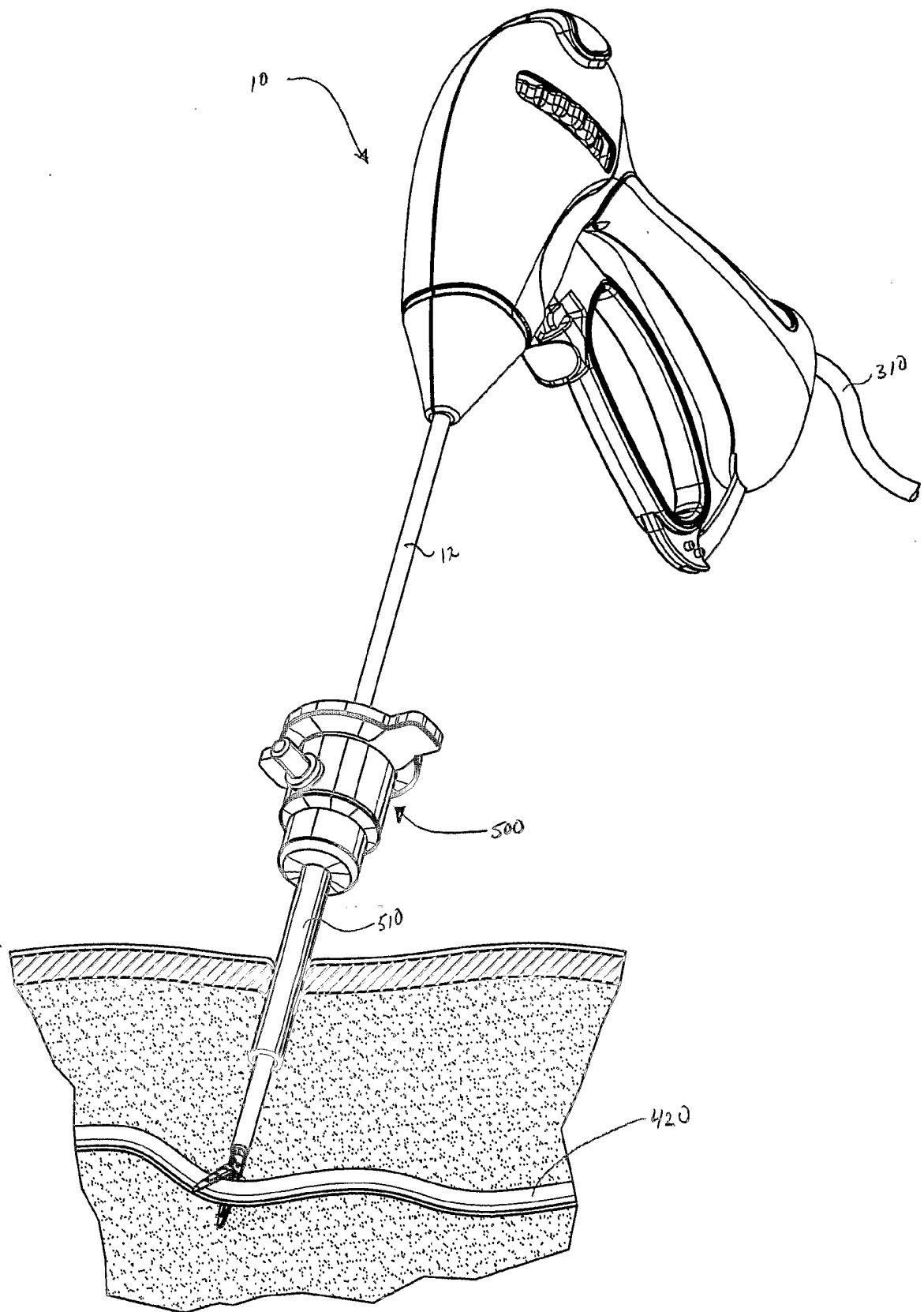

FIG. 36

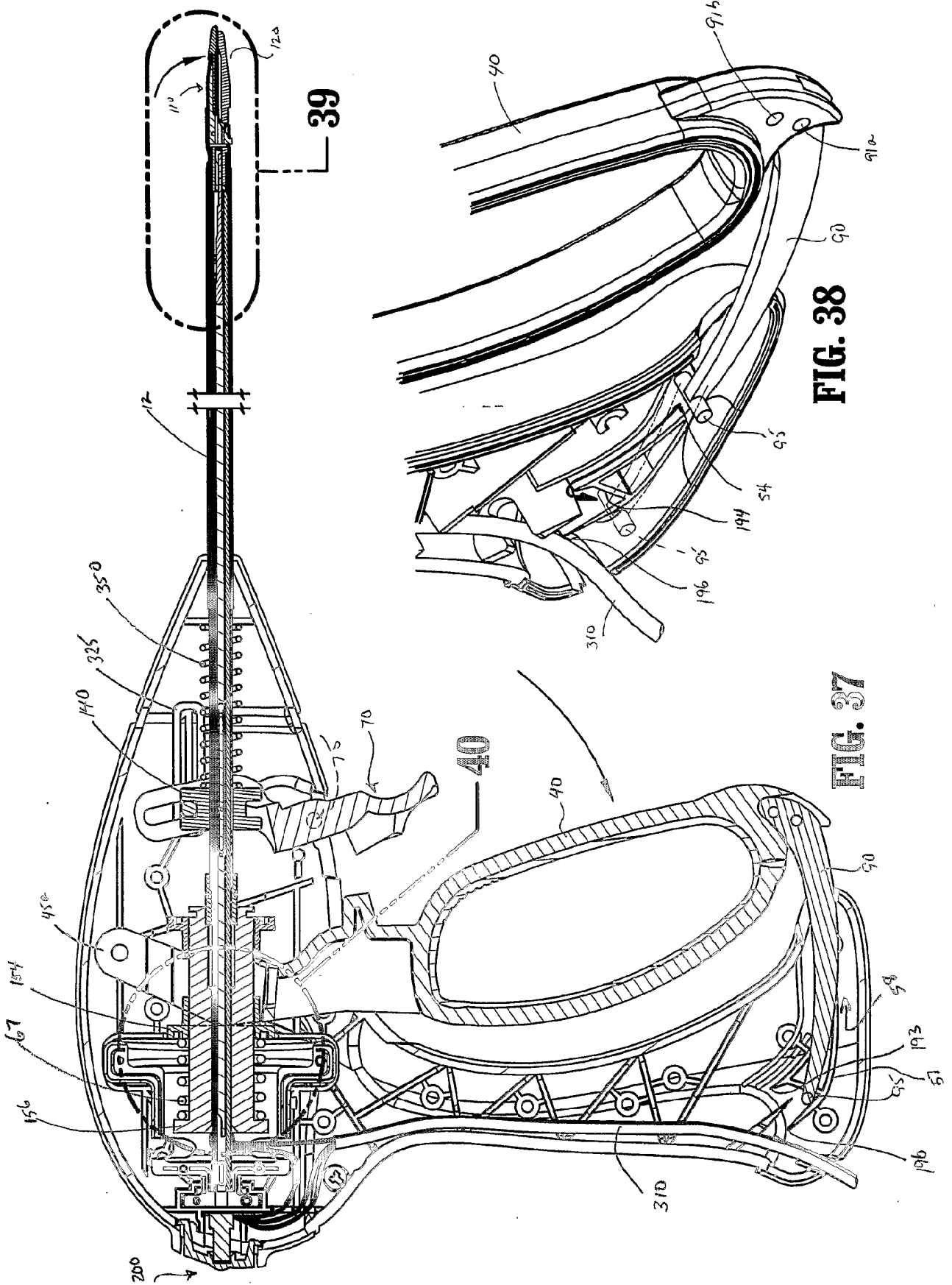

FIG. 38

FIG. 37

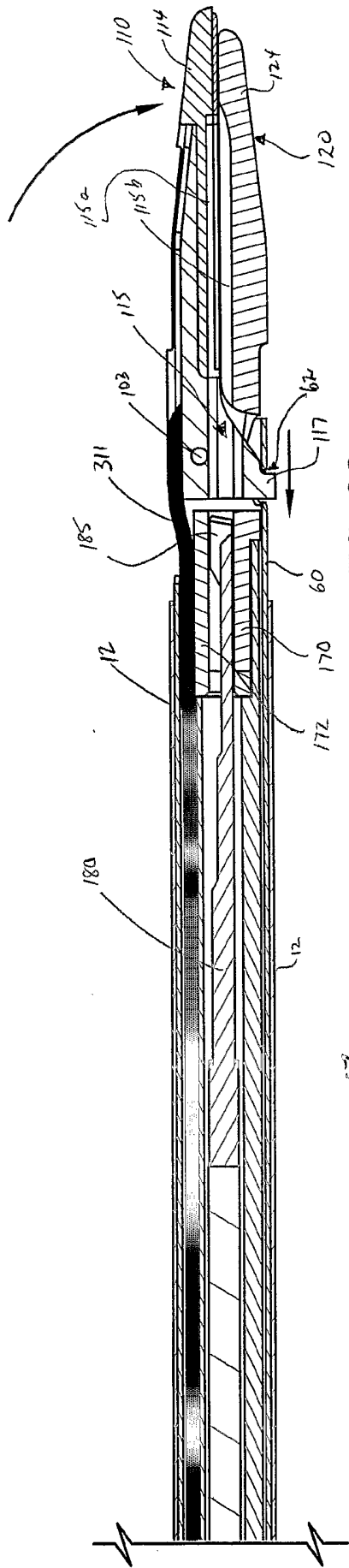

FIG. 39

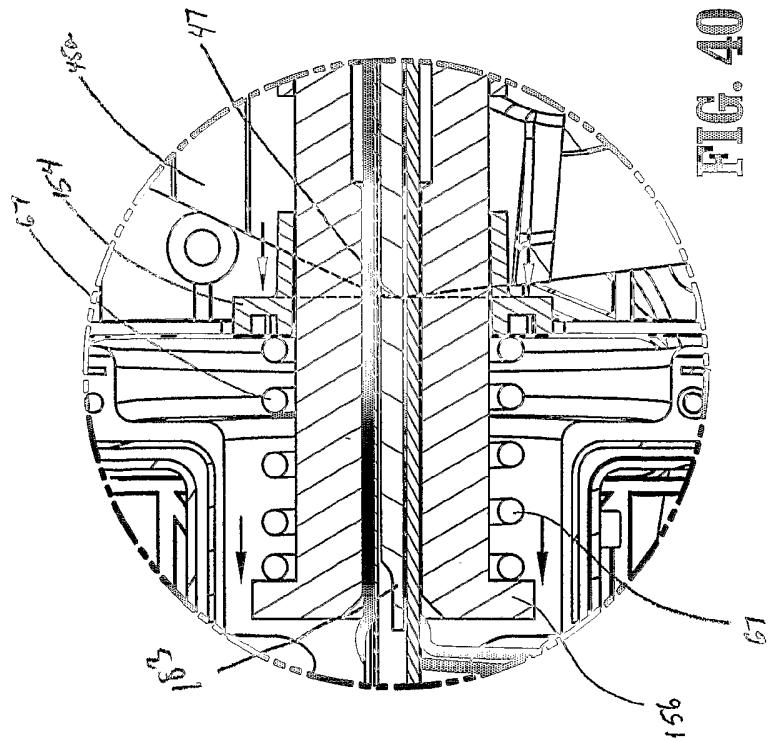

FIG. 40

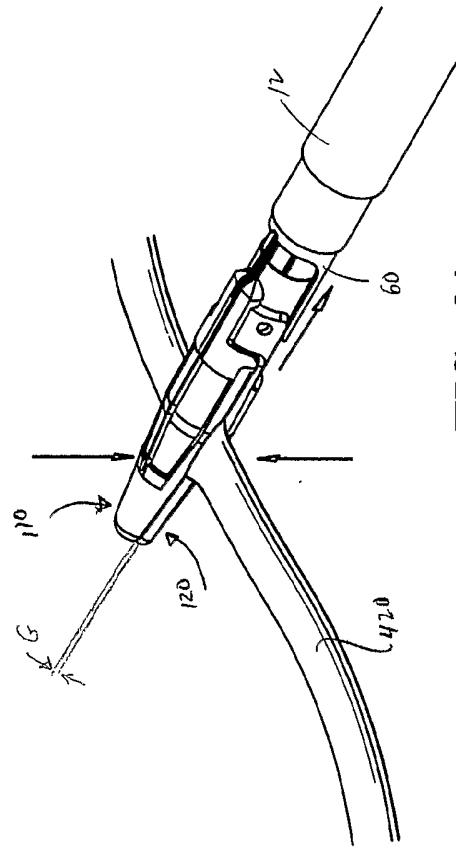

FIG. 41

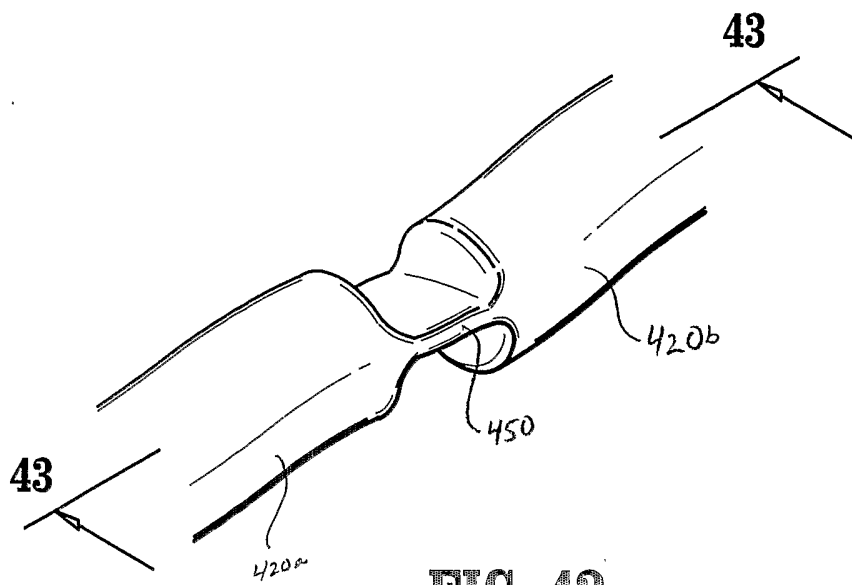

FIG. 42

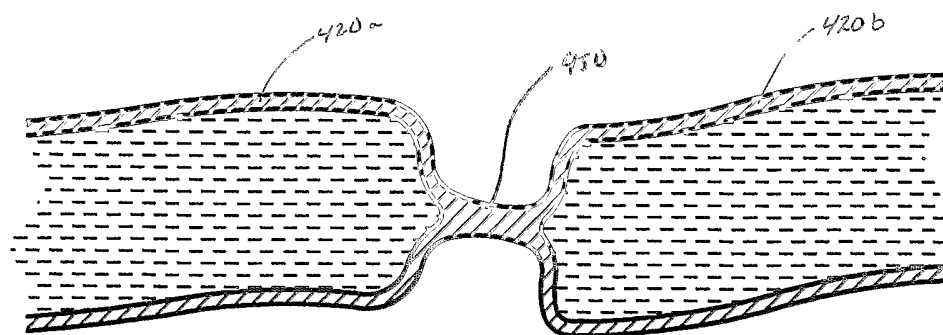
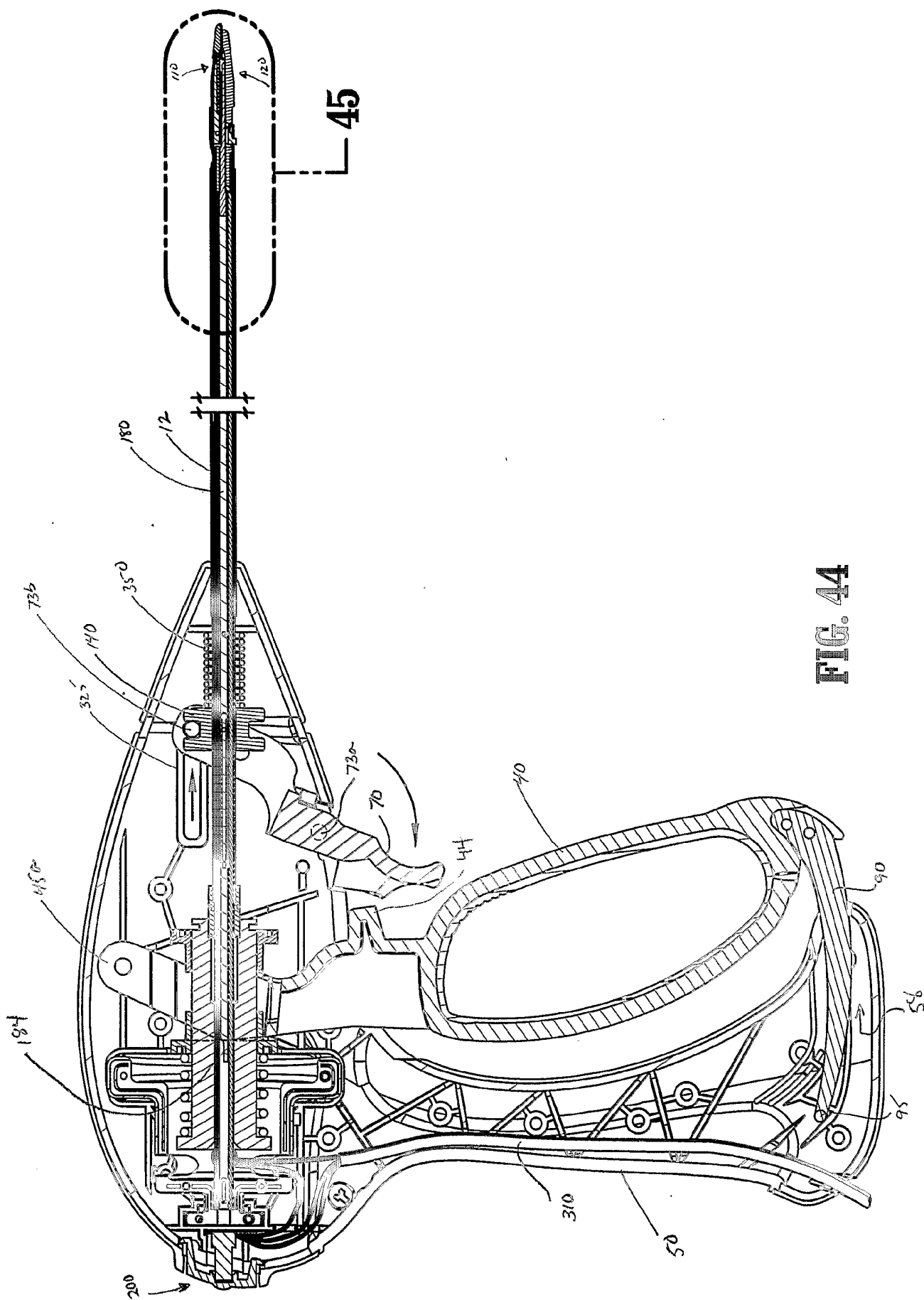

FIG. 43



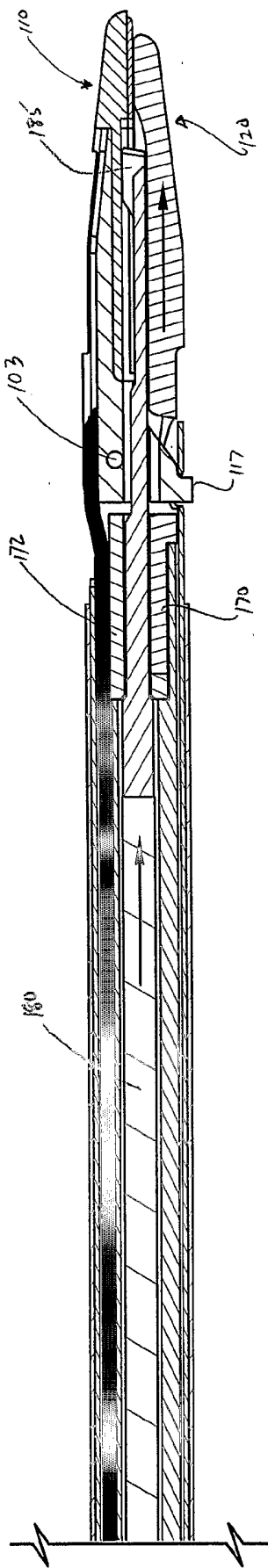

FIG. 45

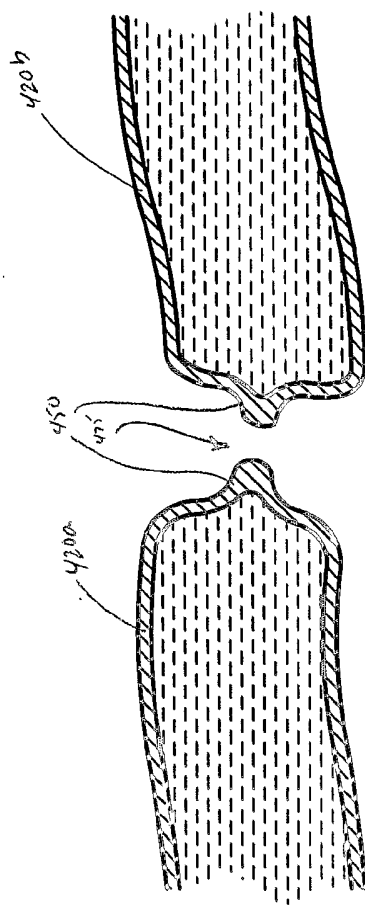
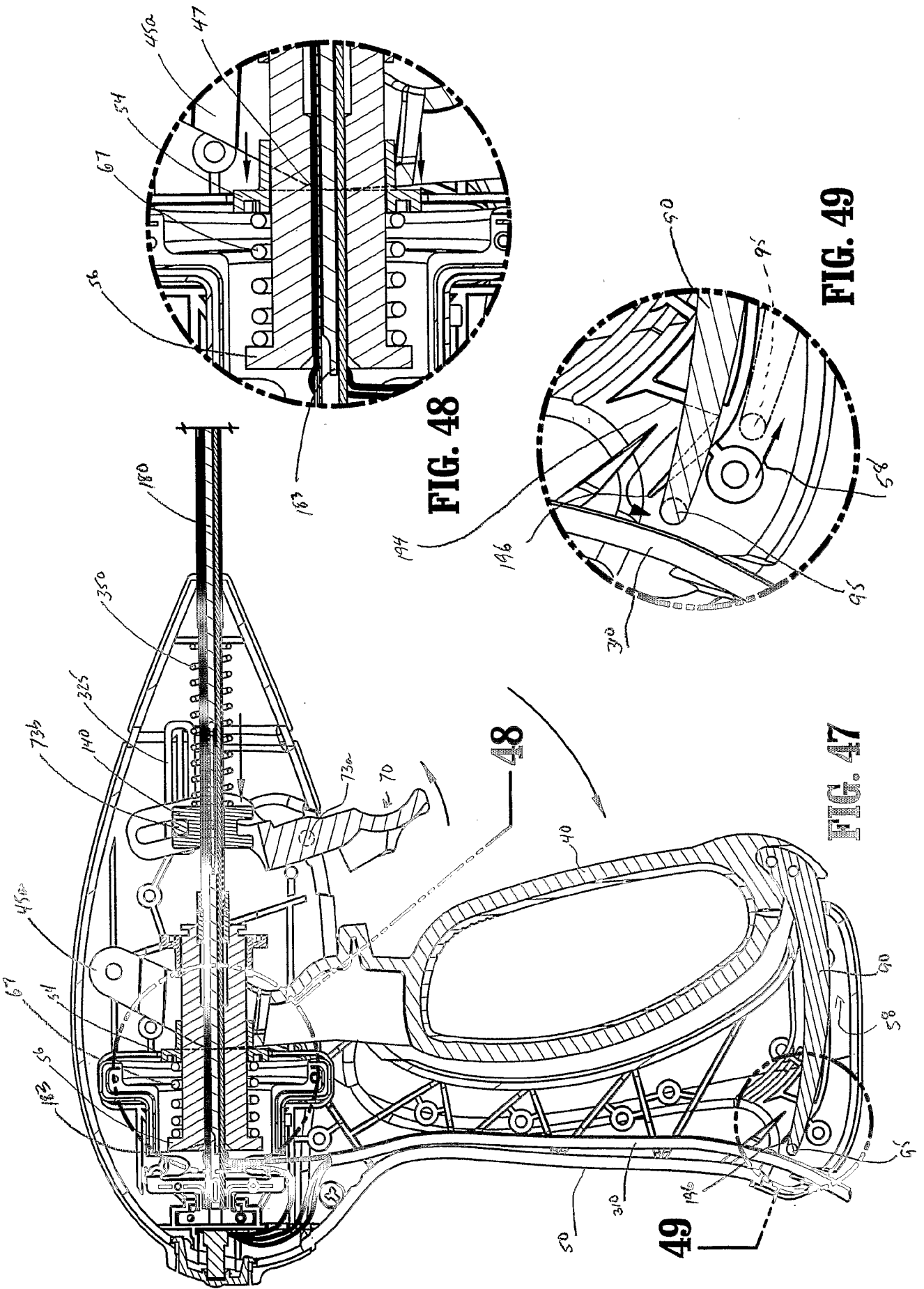

FIG. 46



INTERNATIONAL SEARCH REPORT

International Application No
PCT/US 03/18674

A. CLASSIFICATION OF SUBJECT MATTER
IPC 7 A61B18/14

According to International Patent Classification (IPC) or to both national classification and IPC

B. FIELDS SEARCHED

Minimum documentation searched (classification system followed by classification symbols)
IPC 7 A61B

Documentation searched other than minimum documentation to the extent that such documents are included in the fields searched

Electronic data base consulted during the international search (name of data base and, where practical, search terms used)

EPO-Internal, WPI Data, PAJ

C. DOCUMENTS CONSIDERED TO BE RELEVANT

Category °	Citation of document, with indication, where appropriate, of the relevant passages	Relevant to claim No.
X	US 6 443 970 B1 (KNIGHT GARY W ET AL) 3 September 2002 (2002-09-03)	1,2
A	column 6, line 66 -column 16, line 16; claim 1; figure 1	3-12
X	US 6 053 933 A (BALAZS MATTHIAS ET AL) 25 April 2000 (2000-04-25)	1,3
A	column 4, line 30 -column 7, line 18; claim 1; figure 1	11
X	WO 01 54604 A (AESCULAP AG & CO KG ;ROTHWEILER CHRITSTOPH (DE); WEISSHAUPT DIETER) 2 August 2001 (2001-08-02)	1
A	abstract; claim 1; figure 1	2,11
X	EP 0 572 131 A (EVEREST MEDICAL CORP) 1 December 1993 (1993-12-01)	1,2
A	claim 1; figures 1-3	3-12

Further documents are listed in the continuation of box C.

Patent family members are listed in annex.

° Special categories of cited documents :

- *A* document defining the general state of the art which is not considered to be of particular relevance
- *E* earlier document but published on or after the international filing date
- *L* document which may throw doubts on priority claim(s) or which is cited to establish the publication date of another citation or other special reason (as specified)
- *O* document referring to an oral disclosure, use, exhibition or other means
- *P* document published prior to the international filing date but later than the priority date claimed

- *T* later document published after the international filing date or priority date and not in conflict with the application but cited to understand the principle or theory underlying the invention
- *X* document of particular relevance; the claimed invention cannot be considered novel or cannot be considered to involve an inventive step when the document is taken alone
- *Y* document of particular relevance; the claimed invention cannot be considered to involve an inventive step when the document is combined with one or more other such documents, such combination being obvious to a person skilled in the art.
- *Z* document member of the same patent family

Date of the actual completion of the international search

Date of mailing of the international search report

12 September 2003

18/09/2003

Name and mailing address of the ISA

European Patent Office, P.B. 5818 Patentlaan 2
NL - 2280 HV Rijswijk
Tel. (+31-70) 340-2040, Tx. 31 651 epo nl,
Fax: (+31-70) 340-3016

Authorized officer

Chopinaud, M

INTERNATIONAL SEARCH REPORT

Information on patent family members

International Application No PCT/US 03/18674

Patent document cited in search report	Classification	Publication date		Patent family member(s)	Publication date
US 6443970	B1	25-07-2002	US	2002099370 A1	25-07-2002
			WO	02058580 A1	01-08-2002
			US	2002177849 A1	28-11-2002
<hr style="border-top: 1px dashed black;"/>					
US 6053933	A	25-04-2000	DE	19632298 A1	12-02-1998
<hr style="border-top: 1px dashed black;"/>					
WO 0154604	A	02-08-2001	DE	10003020 A1	23-08-2001
			AT	243004 T	15-07-2003
			WO	0154604 A1	02-08-2001
			EP	1250102 A1	23-10-2002
			JP	2003521304 T	15-07-2003
			US	2002183784 A1	05-12-2002
<hr style="border-top: 1px dashed black;"/>					
EP 0572131	A	01-12-1993	CA	2094220 A1	22-11-1993
			EP	0572131 A1	01-12-1993
			JP	6030947 A	08-02-1994
<hr style="border-top: 1px dashed black;"/>					