

Dec. 15, 1931.

C. A. AUDRAIN

1,836,010

AIRPLANE LANDING AND LAUNCHING MECHANISM

Filed May 2, 1930

3 Sheets-Sheet 1

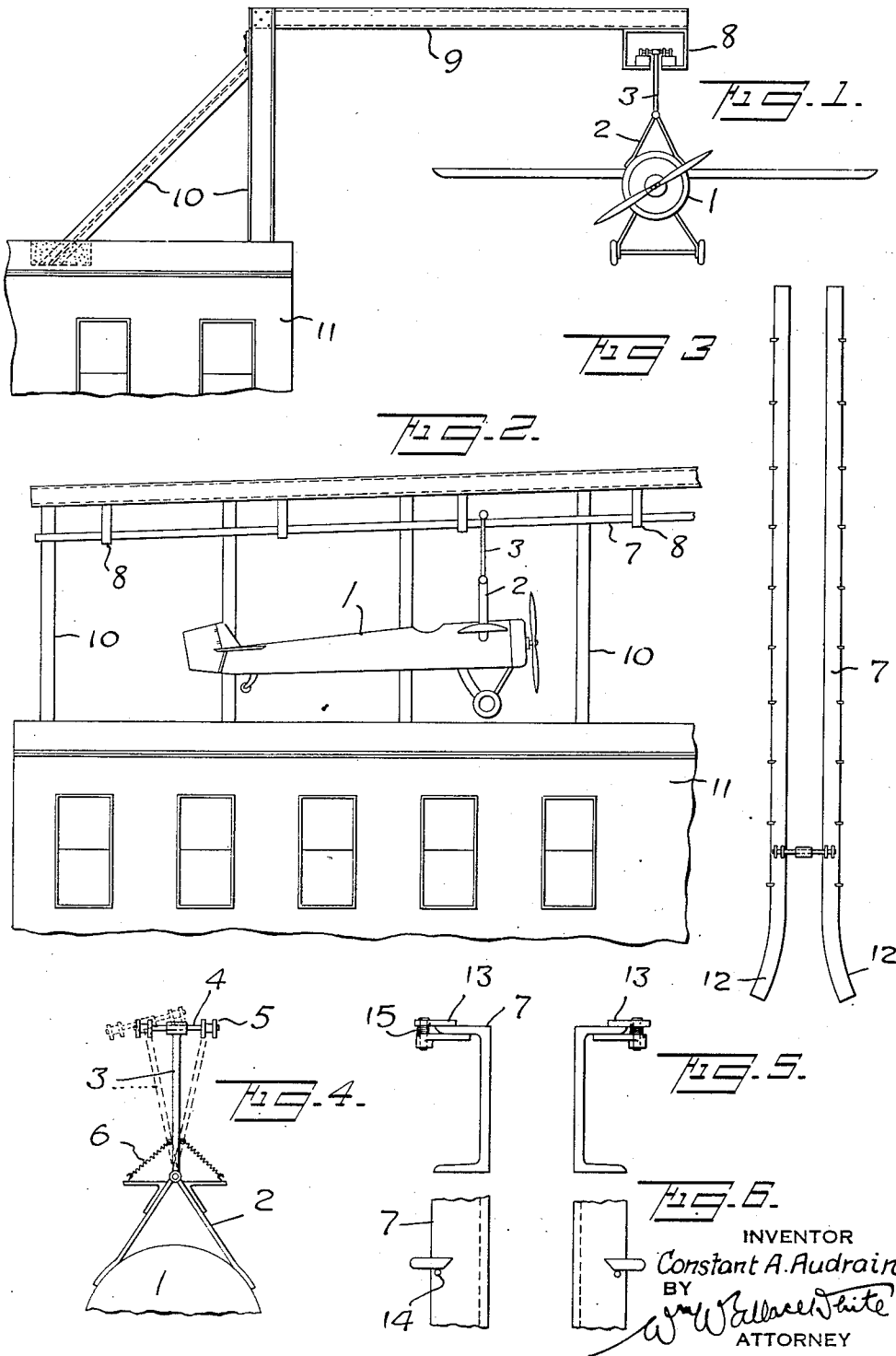

INVENTOR  
Constant A. Audrain.  
BY  
*Wallace White*  
ATTORNEY

Dec. 15, 1931.

C. A. AUDRAIN

1,836,010

AIRPLANE LANDING AND LAUNCHING MECHANISM

Filed May 2, 1930

3 Sheets-Sheet 2

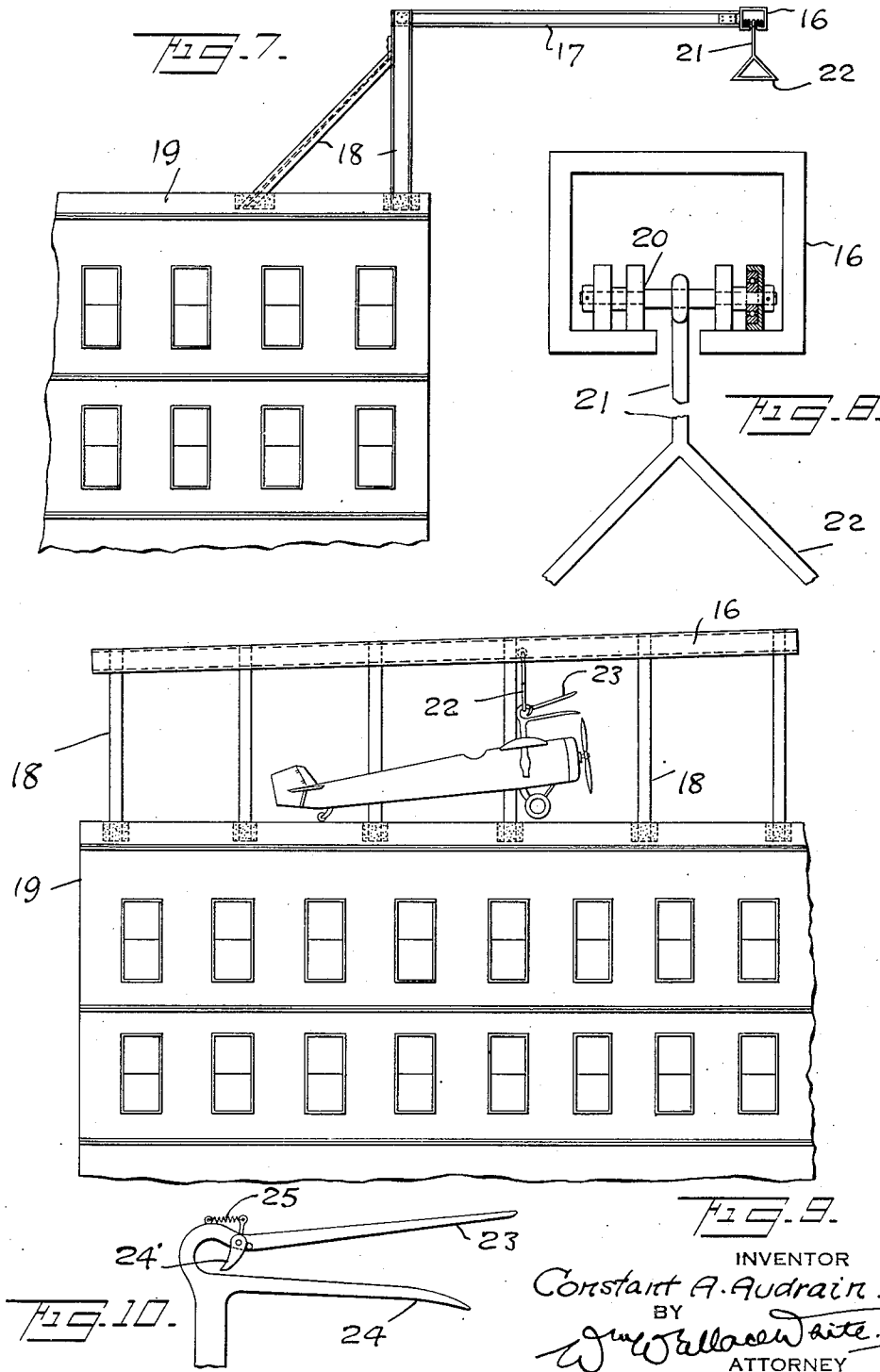

INVENTOR  
Constant A. Audrain.  
BY  
*Wm. Wallace White*  
ATTORNEY

Dec. 15, 1931.

C. A. AUDRAIN

1,836,010

AIRPLANE LANDING AND LAUNCHING MECHANISM

Filed May 2, 1930

3 Sheets-Sheet 3

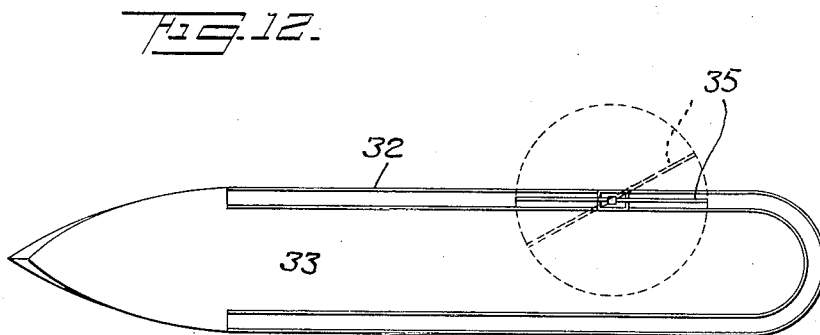
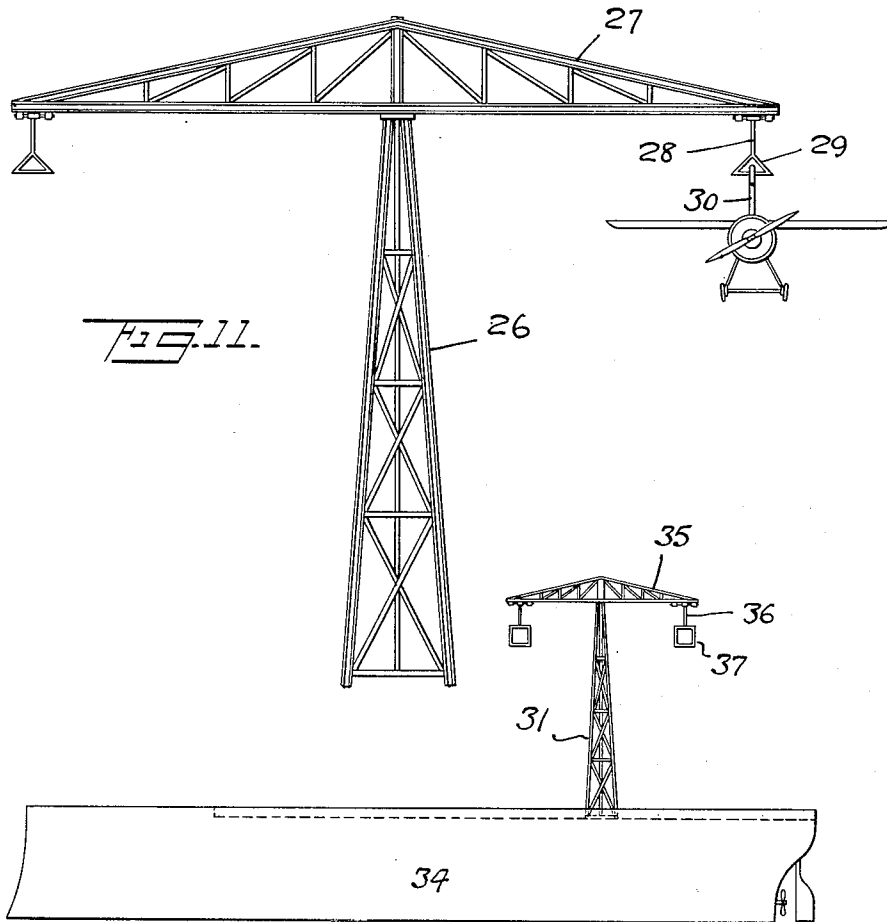

INVENTOR  
Constant A. Audrain.  
BY  
*W. Wallace White*  
ATTORNEY

# UNITED STATES PATENT OFFICE

CONSTANT A. AUDRAIN, OF HABANA, CUBA

## AIRPLANE LANDING AND LAUNCHING MECHANISM

Application filed May 2, 1930. Serial No. 449,235.

This invention relates to improved means for facilitating the launching and landing of aircrafts from the tops of buildings, from the decks of ships or from other places where a landing field of ample area is not available.

One object of this invention is to provide improved means for facilitating the landing of heavier than air machines in restricted spaces and for facilitating the take-off of such machines. A further object of this invention is to provide improved landing and launching means on the tops of buildings and the like with improved means for the engagement and suspension of the machine.

With these and other objects in view, the invention consists in the novel construction and arrangement of parts hereinafter described, illustrated in the accompanying drawings, and particularly pointed out in the appended claims, it being understood that various changes in the form, construction and details may be made without departing from the spirit of the invention or sacrificing any of the advantages thereof.

In the drawings Fig. 1 is an end view showing one form of my improved landing or launching gear attached to the top of a building and showing an airplane suspended therefrom; Fig. 2 is a side view showing a part of the same; Fig. 3 is a plan view showing part of the same apparatus; Fig. 4 is a detail view of the attachment carried by the airplane; Figs. 5 and 6 are respectively end and plan views showing the rails for engaging the part shown at Fig. 4; Fig. 7 is an end view of a modified form of my landing and launching gear shown attached to the top of a building; Fig. 8 is an enlarged detail view showing part of the gear illustrated at Fig. 7; Fig. 9 is a side view looking on the right hand side of Fig. 7 and showing an airplane suspended from the supporting means; Fig. 10 is a detail view of the engaging member attached to the airplane; Fig. 11 is a front view of a modified structure with an airplane suspended therefrom; Fig. 12 is a side view showing a ship carrying a structure according to this invention and Fig. 13 is a plan view corresponding to Fig.

Referring to Figs. 1 to 6 inclusive, the airplane 1 is provided—see particularly Fig. 4—on the upper part thereof and near its center of gravity with a bracket 2 carrying a pivoted bar 3 with a cross bar 4 at its upper end. The outer extremities of the cross bar 4 are fitted with rollers or wheels 5, and springs 6 are provided for retaining the bar 3 yieldingly in a substantially vertical position relatively to the airplane and the dotted lines at Fig. 4 show how the parts 3, 4 may move when submitted to side pressure.

When the airplane 1 is supported from the structure the said wheels 5 rest upon parallel rails 7 consisting of channel bars arranged with their webs facing each other as shown at Figs. 5 and 6. These rails 7 are supported by brackets 8 from projecting beams 9 carried by the supports 10 mounted on the roof of the building 11. As is clearly shown at Fig. 2 the rails 7 are inclined and (see Fig. 3) are flared away from each other at the lower or receiving end 12 of the rails 7. The flared ends 12 facilitate introduction of the rod 13 between the rails 7 and as the wheels 5 are brought to bear on the upper surfaces of the rails 7 the momentum of the airplane is reduced by the inclined rails and in order to prevent backward movement of the airplane after it has been brought to rest, the surfaces of the rails 7 are provided with stop devices—see Figs. 5 and 6—consisting of the pivoted members 13 which are each held yieldingly against stop pins 14 by a spring 15 so that as the wheels 5 move up the inclined rails 7 the members 13 swing against the action of the springs 15 but backward movement of the wheels 5 is prevented by the stop pins 14 which prevent the members 13 from swinging backwardly.

Referring to Figs. 7 to 10 of the drawings, an enclosed inclined trackway 16 is supported by projecting arms 17 mounted on supports 18 on the roof of the building 19. This enclosed trackway 16 supports a carriage 20, having suspended therefrom a bar 21 carrying a triangular or other closed loop or frame 22 adapted to be engaged by a hook device 23 rigidly or yieldingly mounted on the top of the airplane. This hook device

comprises two forwardly extending jaws 23, 24 extending away from each other at their forward ends so as to facilitate introduction of the member 23 into the frame 22, as the airplane is in flight. In order to prevent accidental detachment of the hook device 23, from the frame 22 a spring gate or pawl 24'—see Fig. 10—is provided. This pawl being adapted to yield against the action of the spring 25 as the hook device engages the frame and to then ensure against accidental disengagement.

In the structure shown at Fig. 11 a fixed support 26 carries a rotary beam structure 27 having suspended from each of its outer ends a pivoted bar 28 carrying a triangular or other open frame 29 adapted to be engaged by a hook device 30 on the airplane, the arrangement being such that when the airplane is brought into engagement with the frame 29 the momentum of the plane causes the beam structure 27 to rotate about the vertical center line of the supporting structure 26 so that the airplane is brought to rest.

In the arrangement illustrated at Figs. 12 and 13 an upright structure 31 has a base or carriage mounted on rails or guides 32 on the deck 33 of a ship 34 so that the structure 31 may be shifted from place to place on the deck of the ship to suit circumstances and conditions. The structure 31 supports a rotary beam structure 35 having pivoted bars 36 carrying depending frame structures 37 for engagement by hook devices on the airplane.

The frame devices 29, 37 of Figs. 11 and 12 respectively may be of any convenient shape or structure and are preferably secured to their supporting structures 26—29 respectively in such manner that they may swing or yield in one or more directions for the purpose of taking up the shock when these frames are engaged by the airplane.

Although the drawings and the above specification disclose the best mode in which I have contemplated embodying my invention, I desire to be in no way limited to the details of such disclosure for in the further practical application of my invention many changes in form and construction may be made as circumstances require or experience suggests without departing from the spirit of the invention within the scope of the appended claims.

What I claim is:

1. Airplane landing and launching mechanism comprising lateral supporting means, guide rails thereon, a frame carried on said guide rails, and means on the airplane for penetrating the said frame to suspend the airplane therefrom.

2. Airplane landing and launching mechanism comprising upright means, lateral supports carried thereby, inclined rails carried by the lateral supports, a frame suspended

from the inclined rails, and means on an airplane for penetrating such frame to suspend the airplane therefrom.

3. Airplane landing and launching mechanism comprising an upright structure, lateral supports extending therefrom, an inclined trackway carried by said lateral supports, a carriage on said trackway, means for preventing movement of the carriage in one direction, and means suspended from the carriage for engaging the airplane.

4. Airplane landing and launching mechanism comprising lateral supporting means, a pair of inclined rails carried by said means, a carriage on said rails, a suspended frame beneath said rails, means extending between the rails and connecting the carriage with said frame, and means on the airplane for engaging said frame.

5. Airplane landing and launching mechanism comprising an upright structure, lateral supports extending therefrom, a frame device movable relatively to the upright structure, and means on an airplane comprising a member for penetrating said frame, means for guiding said member into said frame and means for preventing accidental disengagement of said member from the frame.

In testimony whereof I have signed my name to this specification.

C. A. AUDRAIN.