

J. S. FAIRFAX.  
Rotary-Engines.

No. 158,579.

Patented Jan. 12, 1875.

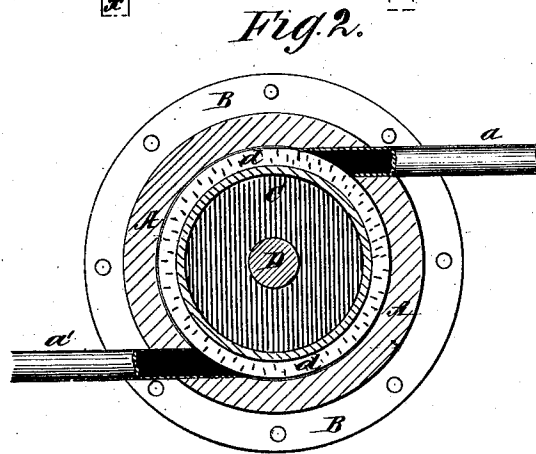
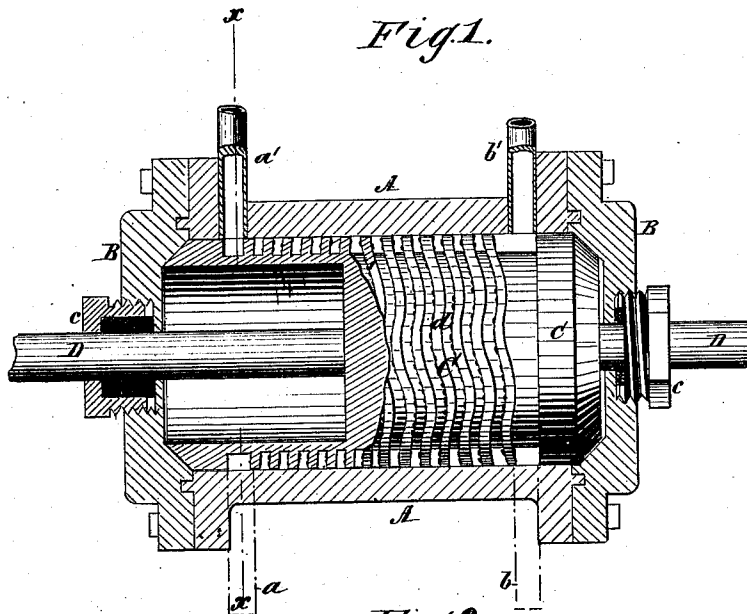

WITNESSES:  
*G. Mather.*  
*J. S. Fairfax.*

INVENTOR.  
*Jos. S. Fairfax*  
BY *Wm. T. C.*  
ATTORNEYS.

# UNITED STATES PATENT OFFICE.

JOSEPH S. FAIRFAX, OF BALTIMORE, MARYLAND.

## IMPROVEMENT IN ROTARY ENGINES.

Specification forming part of Letters Patent No. 133,579, dated January 12, 1875; application filed May 26, 1874.

*To all whom it may concern:*

Be it known that I, JOSEPH S. FAIRFAX, of Baltimore city and State of Maryland, have invented a new and Improved Rotary Engine; and I do hereby declare that the following is a full, clear, and exact description of the same, reference being had to the accompanying drawing forming a part of this specification, in which—

Figure 1 is a longitudinal view of rotary-engine cylinder and case, with case in section and cylinder partly broken away; Fig. 2, a transverse section of the same.

This invention relates to that class of machines which are known as rotary engines; and it consists of a cylinder with its periphery wrought into undulating spiral grooves, which is made to revolve in a surrounding case by the impinging or frictional action of the particles of fluids in their passage through said grooves under pressure.

In the drawing, A represents the cylinder-case, which is provided at its extremities with the four connections *a a'* and *b b'*. B are the detachable head plates or caps for the case, having stuffing-boxes *c*. C is the cylinder, attached to a shaft, D, which revolves in the stuffing-box journals *e*. Upon the periphery of the cylinder C are wrought the spiral grooves or channels *d*, passing round and round the cylinder. Said grooves are undulating in their course, and are provided with uneven and roughened sides, in order to afford as much frictional resistance as possible to the passing of the motive fluid.

The operation of this machine is very simple, for, as the direction of all simple and unobstructed motion is in a straight line, the fluid, in passing through the undulating spiral

grooves, strikes the tortuous sides of the same and also the roughened surface, imparting to the cylinder a portion of its motion, which causes the cylinder to revolve. The case A, being provided with the connections *a a'* for the feed-jets and *b b'* for the exhaust-jets, is so arranged as to cause the motion of the cylinder to be reversed by simply reversing the connections of the feed and exhaust pipes.

This engine is adapted to receive its motion from any kind of fluid, either liquid or gaseous, but is intended to be used in connection with a series of boilers having a revolving grate in common, in which the water under the pressure of the superincumbent steam is the motive power, the water passing from one boiler to another through the engine, and the pipe-connections and furnace-grate being changed from one boiler to another as soon as the first shall have become exhausted.

As a modification of this engine the grooves may be wrought in the inner surface of the casing, the casing in this instance revolving and the cylinder being stationary.

Having thus described my invention, what I claim as new, and desire to secure by Letters Patent, is—

In combination with an outer casing, a revolving cylinder made of suitable material, and having its periphery wrought into undulating spiral grooves with roughened surfaces, for the purpose of affording greater frictional resistance to the impinging particles of the motive fluid, and of utilizing the same by resolving it into a rotary motion, as described.

JOSEPH S. FAIRFAX.

Witnesses:

EDWD. W. BYRN,  
CHAS. A. PETTIT.