

No. 864,232.

PATENTED AUG. 27, 1907.

J. D. DOWNES.
RAILWAY SWITCH.
APPLICATION FILED APR. 1, 1907.

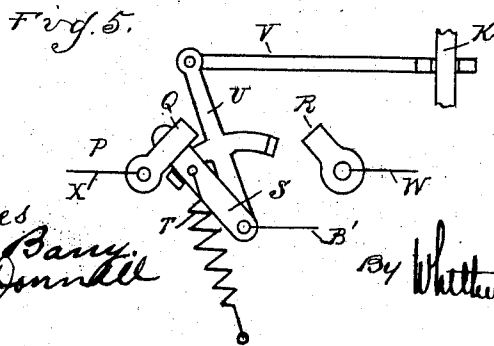
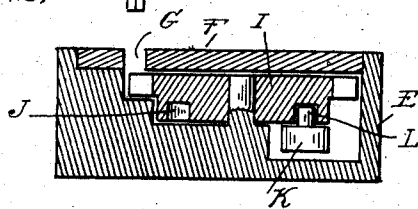
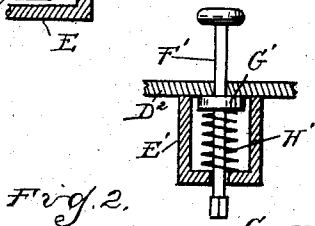
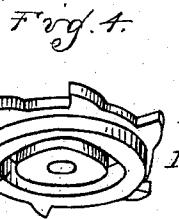
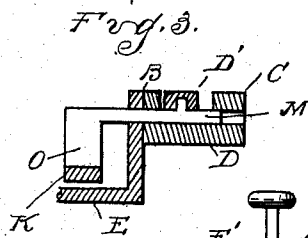
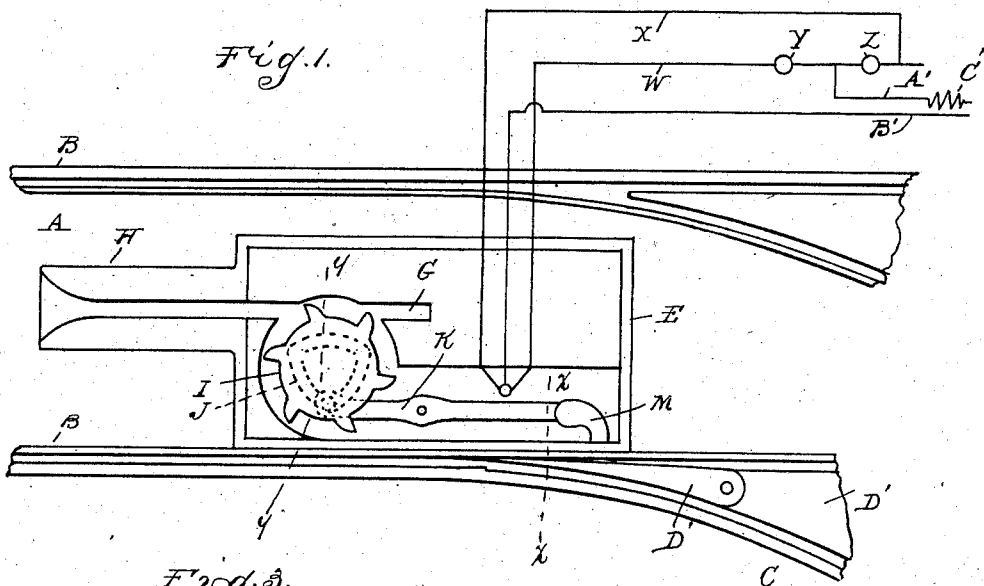

Witnesses
James O. Barry
Thos. O'Donnell

Inventor
James D. Downes

By Whittmore Hulbert Whittmore
attys.

UNITED STATES PATENT OFFICE.

JAMES D. DOWNES, OF DETROIT, MICHIGAN, ASSIGNOR OF ONE-HALF TO CHARLES R. BURKE, OF DETROIT, MICHIGAN.

RAILWAY-SWITCH.

No. 864,232.

Specification of Letters Patent.

Patented Aug. 27, 1907.

Application filed April 1, 1907. Serial No. 365,787.

To all whom it may concern:

Be it known that I, JAMES D. DOWNES, a citizen of the United States of America, residing at Detroit, in the county of Wayne and State of Michigan, have invented certain new and useful Improvements in Railway-Switches, of which the following is a specification, reference being had therein to the accompanying drawings.

The invention relates particularly to an operating mechanism for railway switches especially designed for use on electric railways, and adapted to be operated by the motorman on the platform of the car, and consists in the novel construction of the switch-operating mechanism, in the peculiar arrangement and combination of its parts, and further in an indicator controlled by the switch mechanism for indicating the position of the switch-point, as will be more fully hereinafter set forth.

In the drawings,—Figure 1 is a plan view of the switch mechanism, with the indicating means shown diagrammatically; Fig. 2 is a section taken on line $y-y$ of Fig. 1; and a sectional view of the operating means on the car for shifting the switch-point; Fig. 3 is a section on line $x-x$ of Fig. 1; Fig. 4 is a detached perspective view of the cam-wheel forming part of the operating mechanism, and Fig. 5 is a diagrammatic plan view of an electric switch forming part of the indicating mechanism.

In the drawings thus described, A represents the roadbed, B the rails of the main track, and C the rails of a branch track or siding.

D represents the usual switch-plate or casting, on which is pivotally mounted the switch-point D'.

E designates a housing arranged intermediate the rails of the main track, provided with a cover-plate or top F, slotted as at G at one end to register with a grooved guide member H adapted to receive the switch-operating device on the car.

The switch-operating mechanism comprises a toothed cam-wheel I horizontally mounted in the housing E in such manner that its teeth will successively extend beneath the slot G in the housing top upon the rotation of the wheel.

J represents a cam-way formed in the under side of the wheel, preferably triangular in form, as indicated in Fig. 4.

K represents a main operating lever pivoted intermediate of its ends within the housing, one end extending beneath the cam-wheel and carrying a stud or upright L that engages the cam-way, as indicated in Fig. 2. At its opposite end the lever is provided with an upright O, upon which is mounted a curved arm M extending through slots in the side of the housing and in the switch-plate D beneath the main rail B, the switch-point D' and the branch rail C, as plainly shown in Fig.

1, the switch-point being secured to this arm, so that as the latter is shifted to one position or another the switch-point will be moved into the desired position in relation to the tracks.

Upon the platform d^2 of the car and on the under side thereof is secured a housing E', through which a plunger-rod F' extends, the rod being provided with a collar G', and held normally in a position above the ground by means of a coil-spring H' which encircles the rod and is adapted to be compressed by the operator to throw the switch.

In operation, as the car approaches the switch the operator depresses the plunger, causing the lower end thereof to engage the guide H. As the car advances, the operating member enters the slot G in the housing top, engaging the projecting tooth of the cam-wheel, causing the latter to rotate, thus rocking the main operating lever K and shifting the switch-point, the parts being so constructed that upon each movement of the cam-wheel the switch-point will be moved toward or away from the main track according to its initial position.

In addition to the operating mechanism described, I have provided means for indicating to the motorman the position of the switch-point before the car reaches the switch, so that he may know whether it is necessary to throw the switch-point or not. The means preferably employed are electric lamps of different colors, one designating the switch-point in a position to provide a clear track for the siding or branch, and the other lamp to indicate the position of the switch-point for the main line, these lamps being arranged in any suitable manner above the track where they can be seen by the operator.

The indicating mechanism comprises a switch of any suitable type arranged preferably in the housing E,—such as the ordinary two-point snap-switch illustrated in Fig. 5 and indicated by the reference-letter P.

Q and R designate the switch contacts, S the switch proper, U a switch-operating arm connected to the main operating lever K by a bar V, and T a spring for the switch of the usual construction.

The circuits comprise a lamp circuit, including the leads W and X connected respectively at their terminals with the contacts Q and R, the lamps of different colors Y and Z, and the main or power leads A' and B', the former being connected to the lamp circuit between the lamps and the latter with the switch S, as indicated in Fig. 5.

C' represents any suitable resistance in the power leads for protecting the lamps.

The indicating means is usually employed in the evenings, when the position of the switch cannot be readily seen, and one of the lamps is burning continuously to indicate the position of the switch-point.

Upon the operation of the main lever K, the switch S is thrown from one of its contacts to the other, thereby extinguishing the burning lamp and igniting the other, to indicate the shifted position of the switch-point, the latter lamp remaining lighted until the switch-point is thrown into a different position.

It will be apparent from the construction of the switch mechanism described that, by having the main operating lever extend directly into an operative position with respect to the cam-wheel, the mechanism is materially simplified. Furthermore, by arranging the extension M forming the connection between the main operating lever and the switch-point beneath the latter and the adjoining track rails, said extension forms practically a part of the switch-plate, and provides a substantially unbroken surface upon which the flange of the wheel may run upon the car passing over the switch, thus preventing any shock or pounding.

What I claim as my invention is,—

1. In a switch-operating mechanism, the combination with a switch-point, of an actuating mechanism therefor

including a main operating lever adapted to be actuated by means upon the car, an electric switch comprising complementary contacts, a spring-pressed switch proper in operative relation to the contacts, and an operating arm for the switch, a connecting bar intermediate the switch-operating arm and main lever, and pivotally connected to each, complementary electric circuits controlled by the switch, and a signal included in each of said circuits. 25

2. In a switch-operating mechanism, the combination with the main and branch rails, of a switch-point, a cam-wheel horizontally mounted intermediate the main rails and adapted to be operated by means secured to the car platform, a main operating lever having one end operatively associated with the cam-wheel, and a lateral extension connected to the opposite end of said lever, said extension being pivoted to the switch point and extending beneath the latter and the adjoining track rails flush with the under faces of the rail heads, forming a substantially unbroken surface for the wheel flange. 30 35 40

In testimony whereof I affix my signature in presence of two witnesses. 40

JAMES D. DOWNES.

Witnesses:

JAMES P. BARRY,
NELLIE KINSELLA.