

[54] TWO-STAGE PUMP

[75] Inventors: Carl G. Dudeck, Newtown; Richard A. Lametto, West Redding, both of Conn.

[73] Assignee: The Nash Engineering Company, Norwalk, Conn.

[**] Term: 14 Years

[21] Appl. No.: 557,943

[22] Filed: Dec. 5, 1983

[52] U.S. Cl. D15/7

[58] Field of Search D15/7, 9; 417/63, 54

[56] References Cited

U.S. PATENT DOCUMENTS

D. 110,935	8/1938	Voorhees et al.	D15/7
D. 202,145	8/1965	Schroeder et al.	D15/7
D. 229,236	11/1973	Doolin	D15/7
4,257,747	3/1981	Goldman	417/63

OTHER PUBLICATIONS

Nash® Multistage Vacuum Pumps, Bulletin No. 499-C, Copyright 1974 The Nash Engineering Company.

Primary Examiner—Wallace R. Burke
Assistant Examiner—Lynn Wilder

[57] CLAIM

The ornamental design for a two-stage pump, as shown.

DESCRIPTION

FIG. 1 is a perspective view of a two-stage pump showing our new design;
 FIG. 2 is a side elevational view thereof;
 FIG. 3 is an elevational view of the opposite side thereof;
 FIG. 4 is an end elevational view thereof;
 FIG. 5 is an elevational view of the opposite end thereof;
 FIG. 6 is a top plan view thereof; and
 FIG. 7 is a bottom plan view thereof.

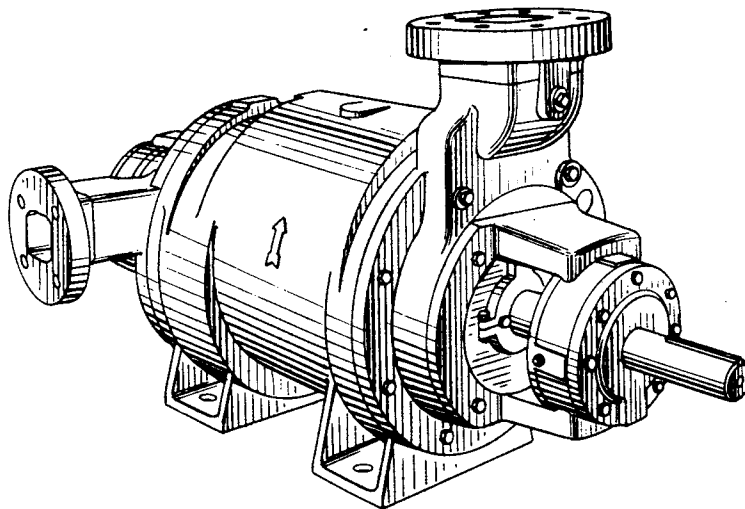

Fig. 1.

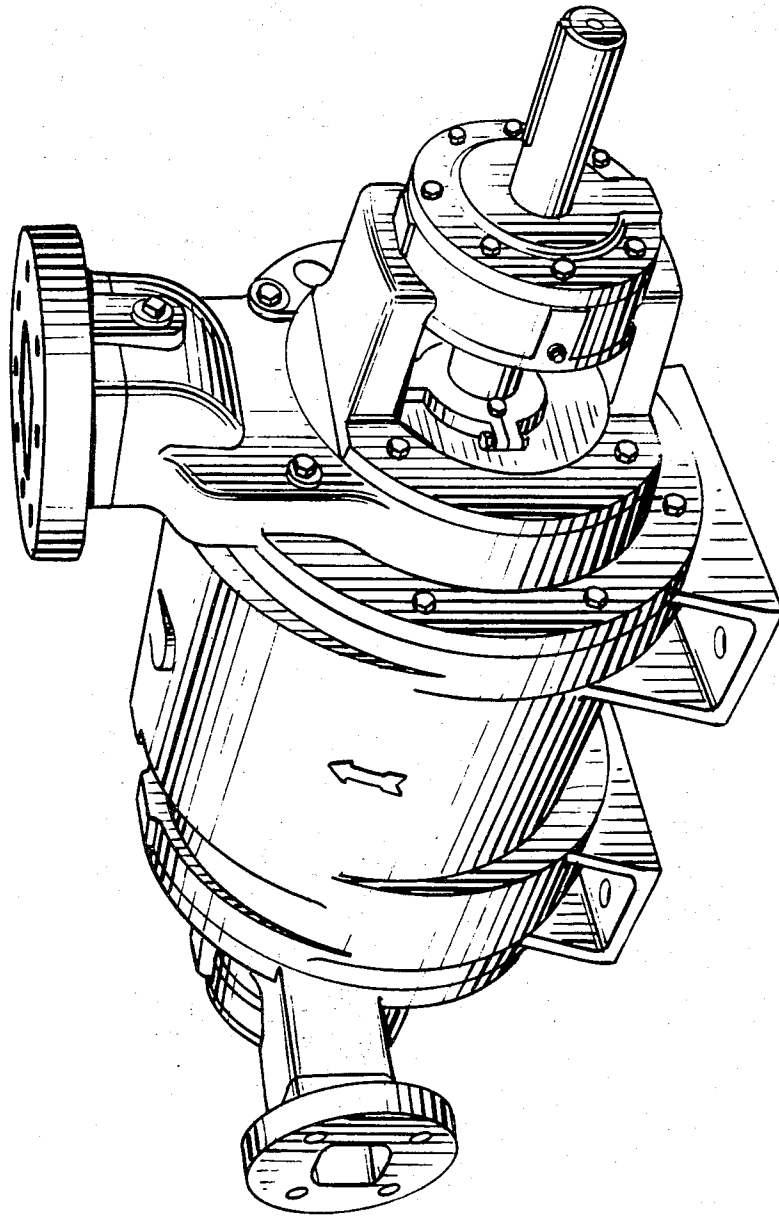

Fig. 2.

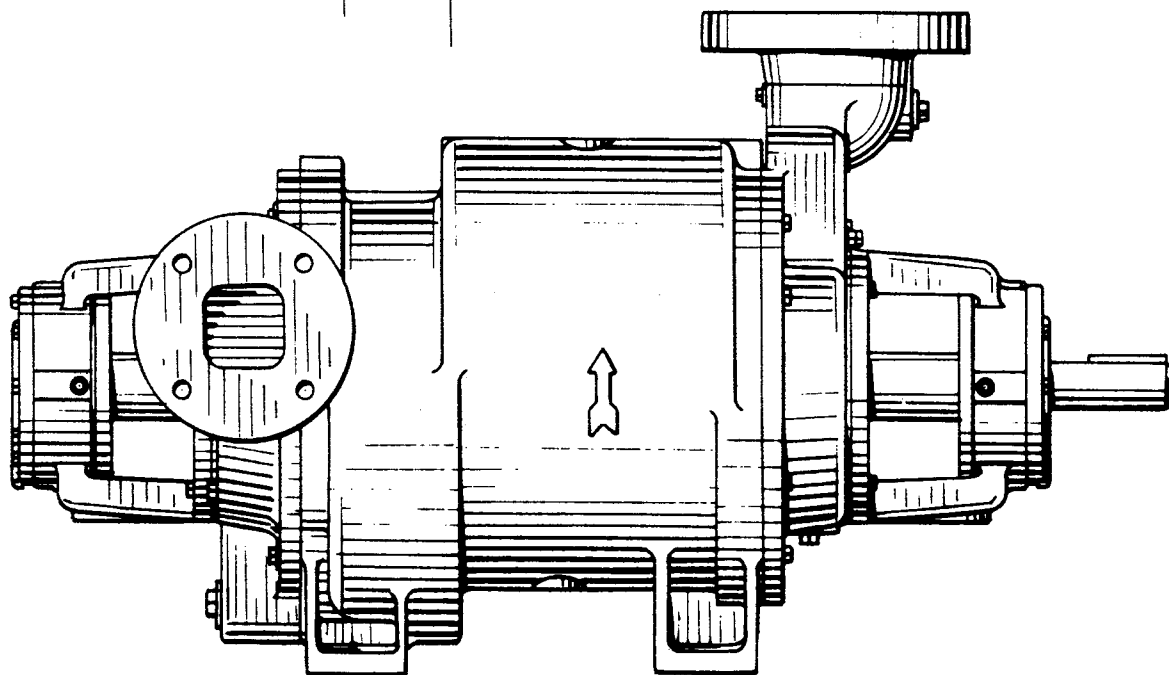
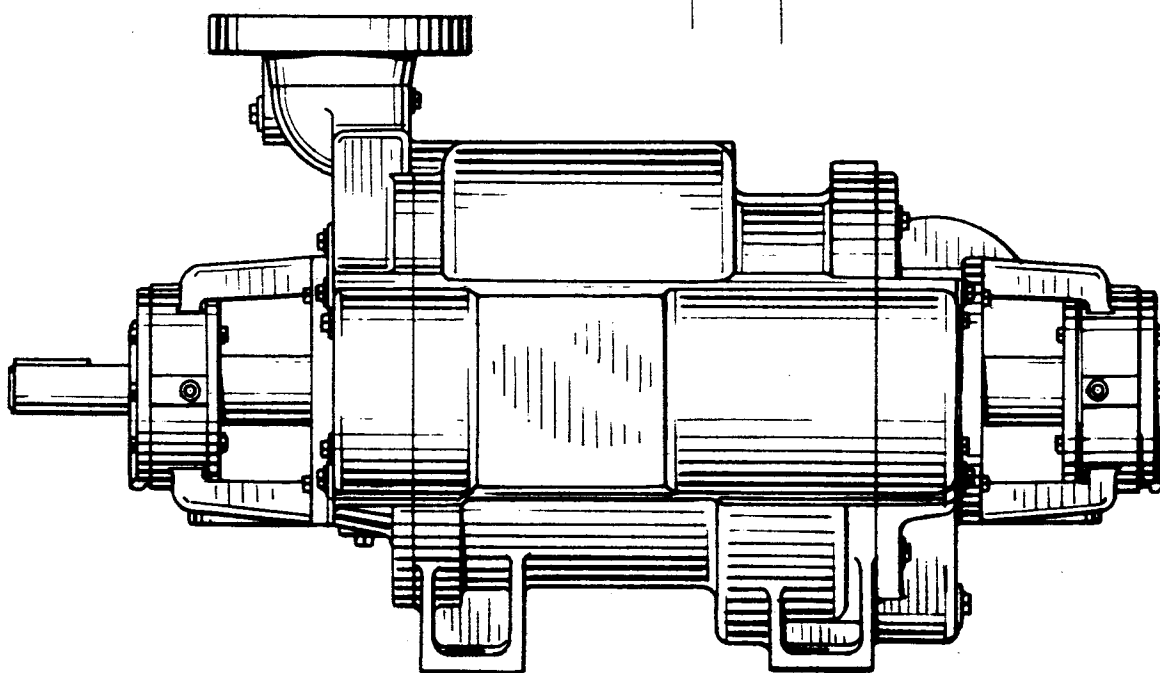

Fig. 3.



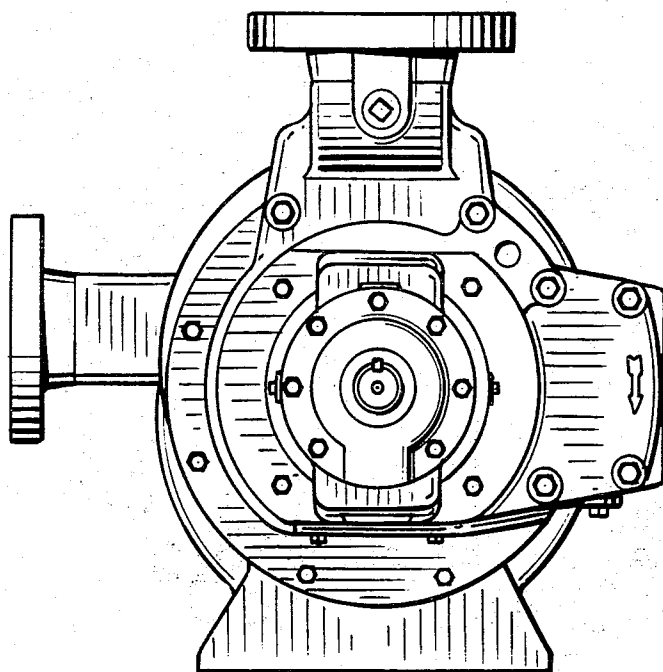
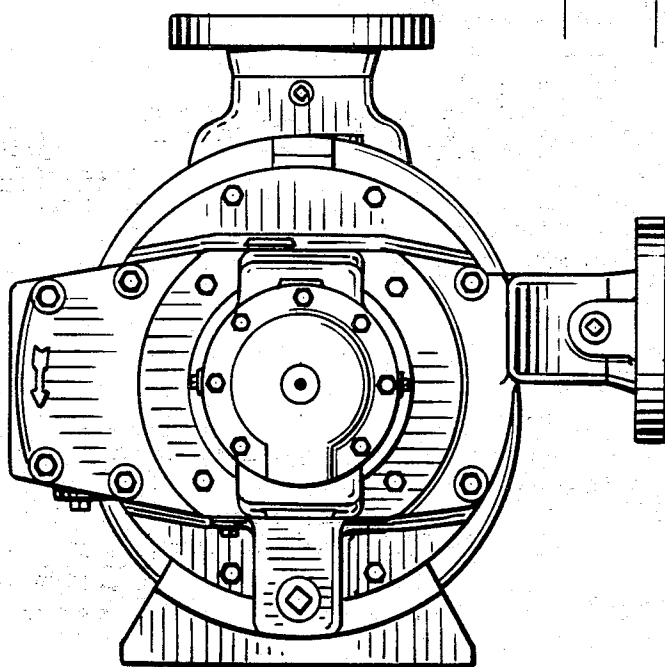

Fig. 4.

Fig. 5.



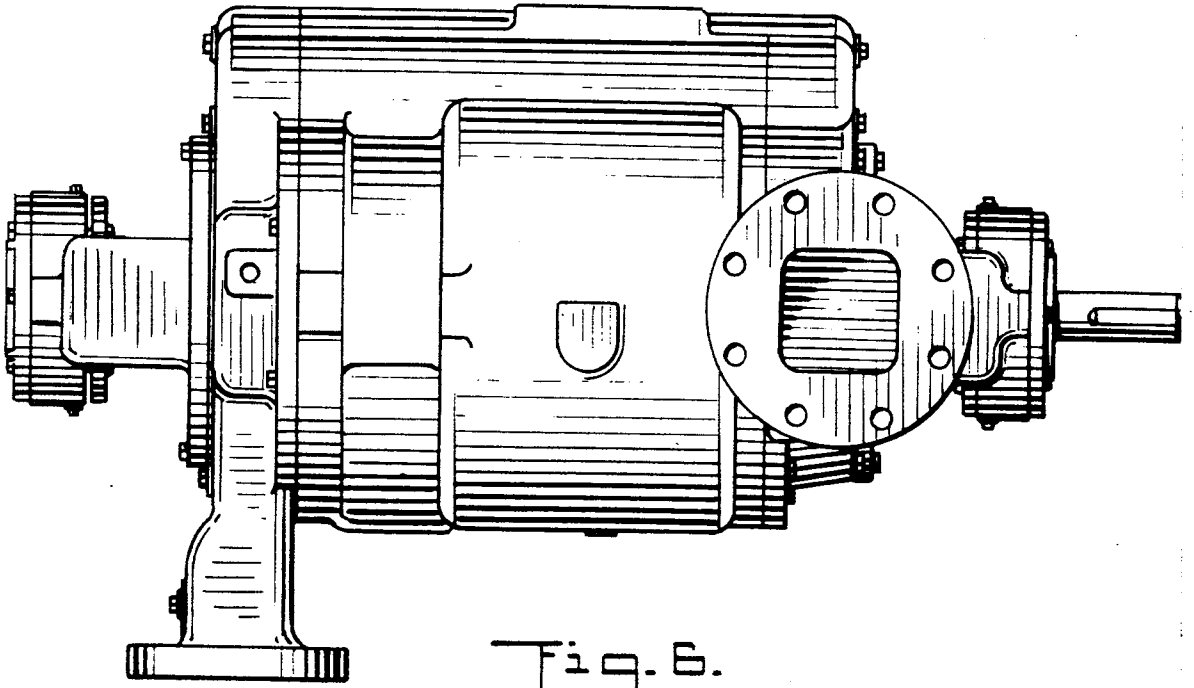

Fig. 6.

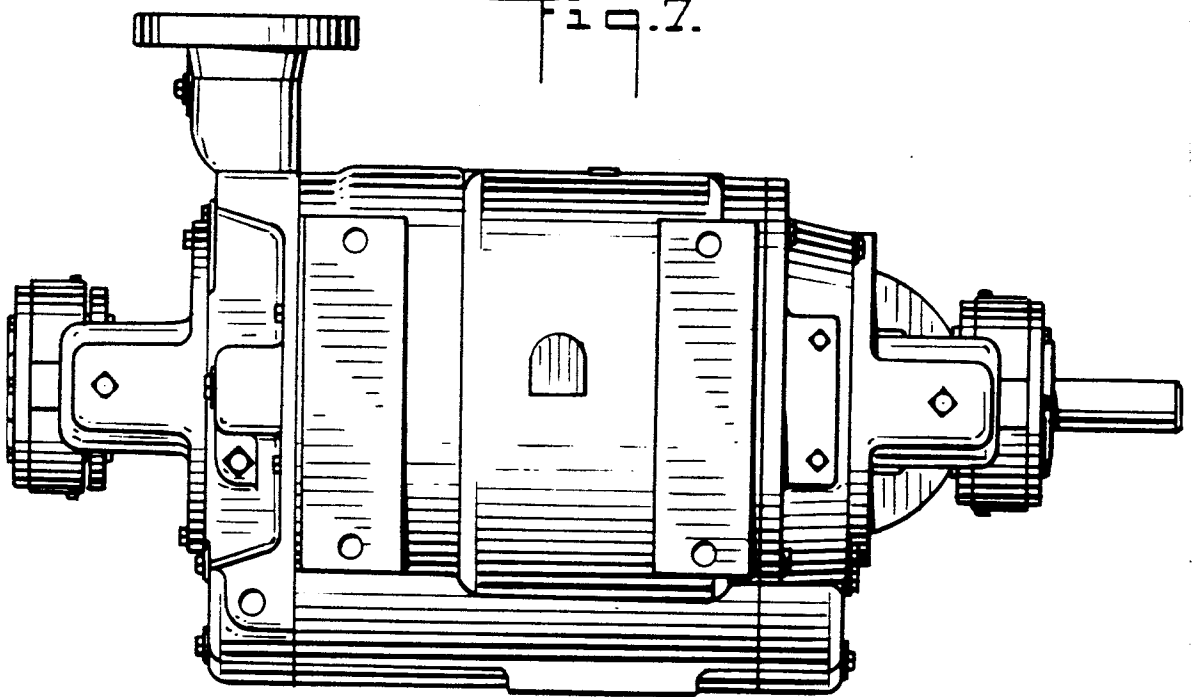

Fig. 7.