

Oct. 13, 1970

C. C. WALLACE ET AL

3,533,204

PRECAST MULTISTORY BUILDING CONSTRUCTION

Filed Dec. 5, 1968

4 Sheets-Sheet 1

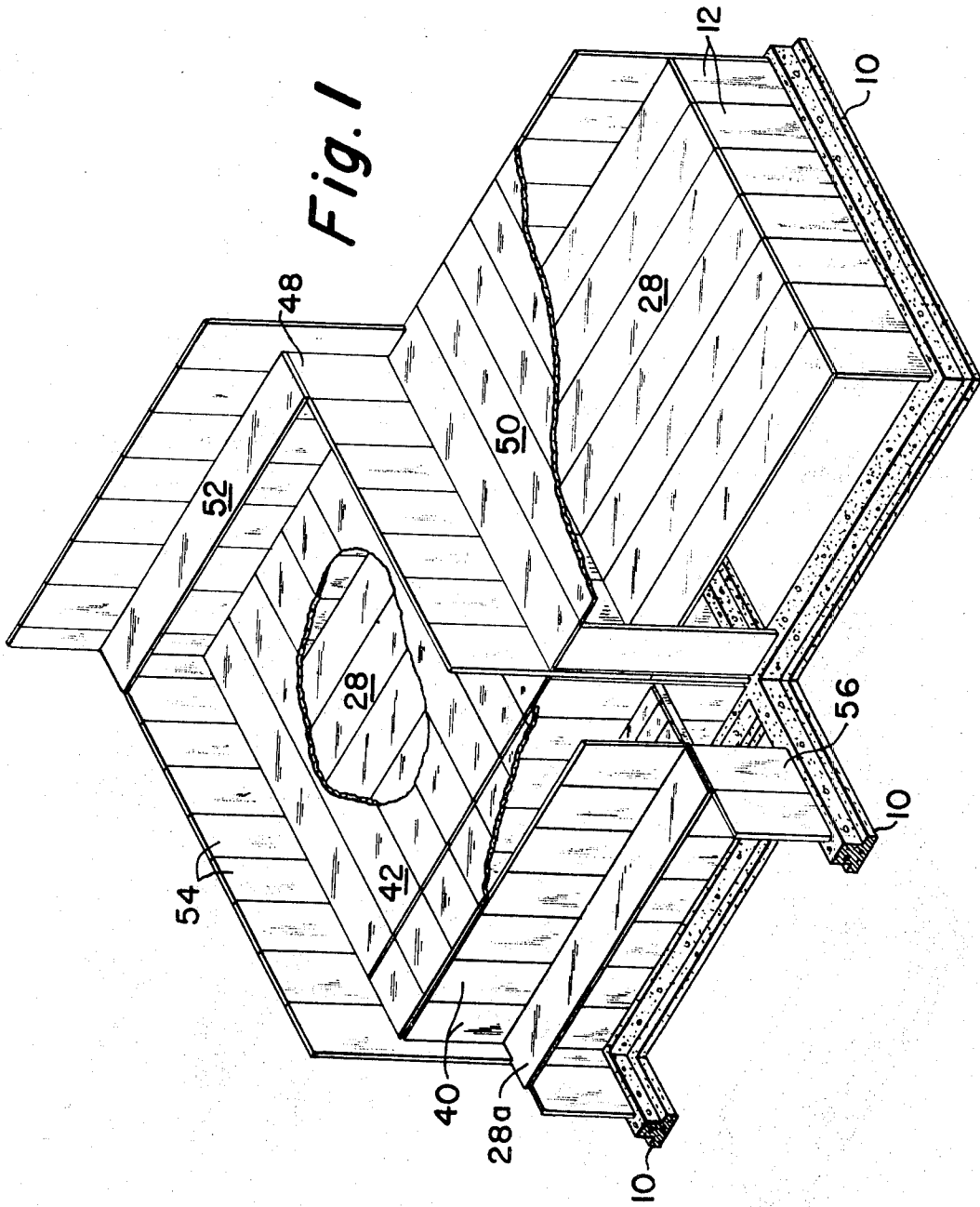

INVENTORS.
Clark C. Wallace
John M. Sweeney
BY
Wells Burden Robinson & Wells
THEIR ATTORNEYS

Oct. 13, 1970

C. C. WALLACE ETAL

3,533,204

PRECAST MULTISTORY BUILDING CONSTRUCTION

Filed Dec. 5, 1968

4 Sheets-Sheet 2

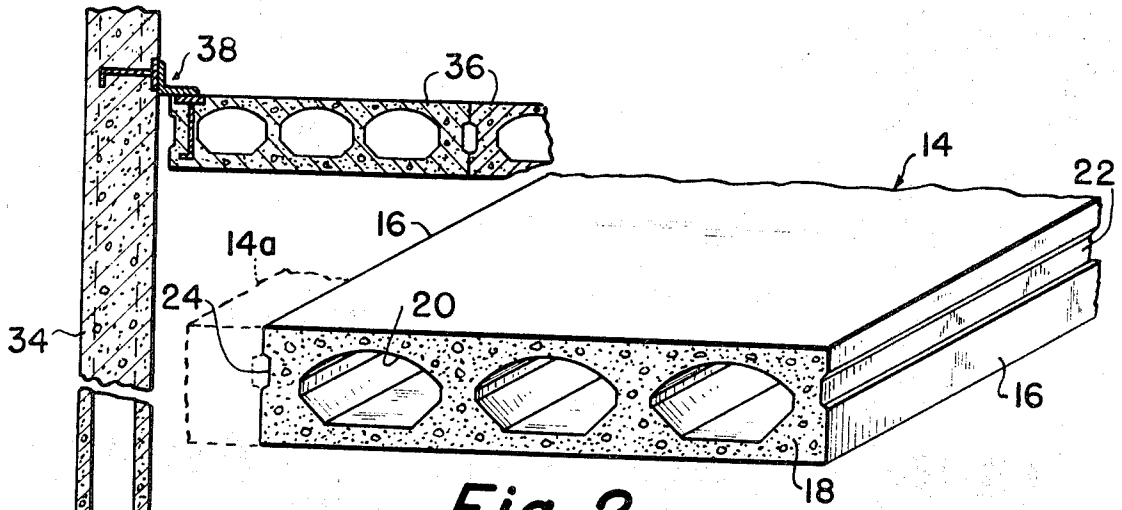

Fig. 2

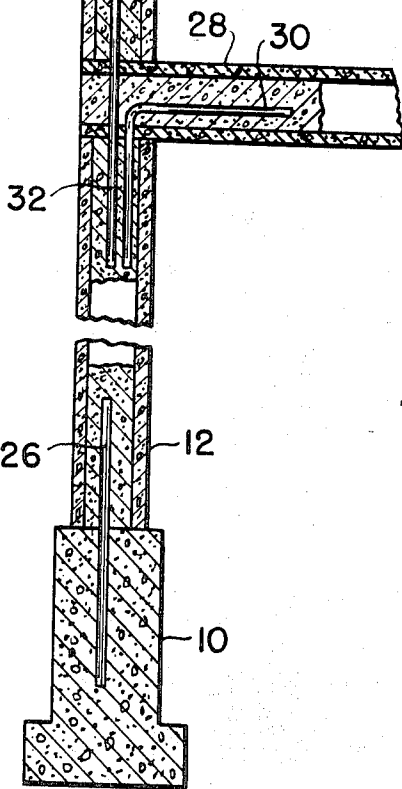

Fig. 3

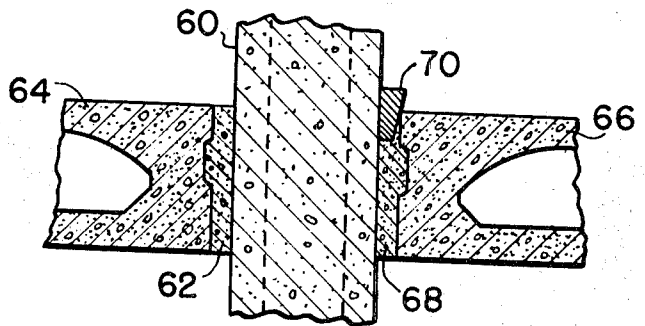

Fig. 5

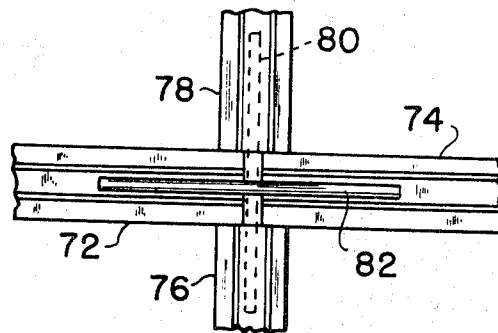

Fig. 7

INVENTORS.
Clark C. Wallace
John M. Sweeney

BY

Walt Bunder Robinson & Webb

THEIR ATTORNEYS

Oct. 13, 1970

C. C. WALLACE ET AL

3,533,204

PRECAST MULTISTORY BUILDING CONSTRUCTION

Filed Dec. 5, 1968

4 Sheets-Sheet 3

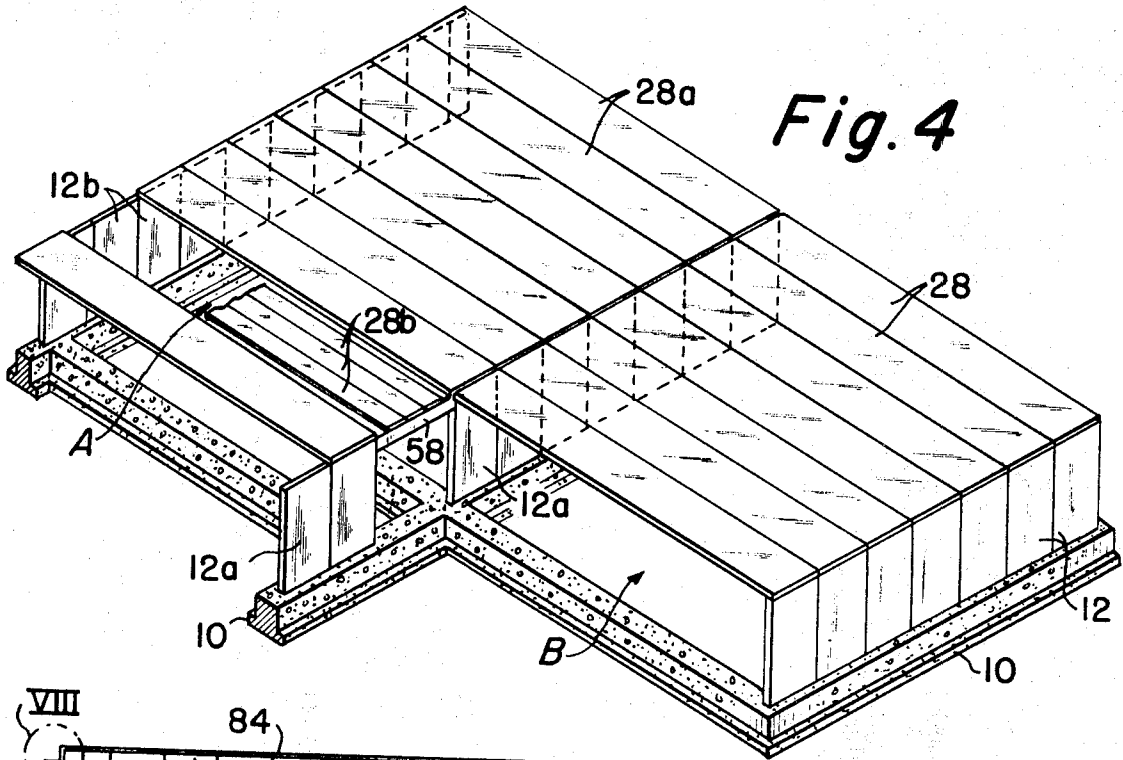

Fig. 4

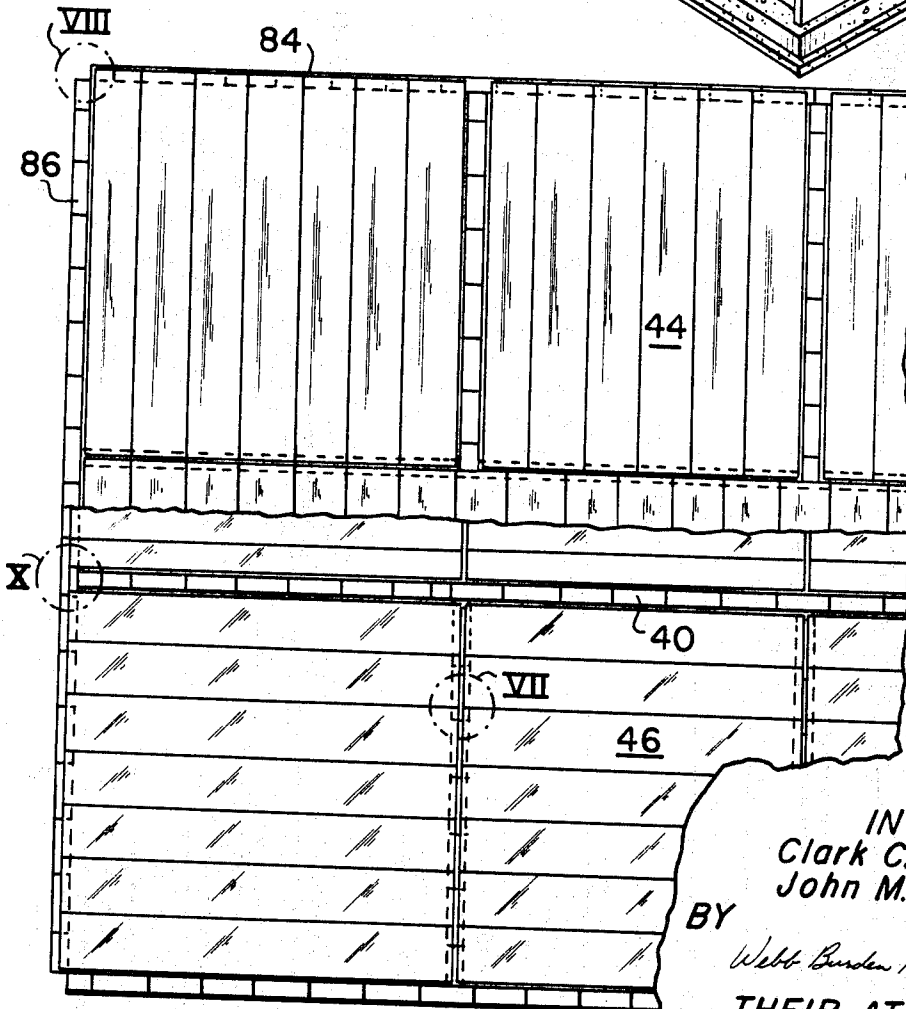

Fig. 6

INVENTORS.
Clark C. Wallace
John M. Sweeney
BY
Webb Burden Robinson & Webb
THEIR ATTORNEYS

Oct. 13, 1970

C. C. WALLACE ET AL

3,533,204

PRECAST MULTISTORY BUILDING CONSTRUCTION

Filed Dec. 5, 1968

4 Sheets-Sheet 4

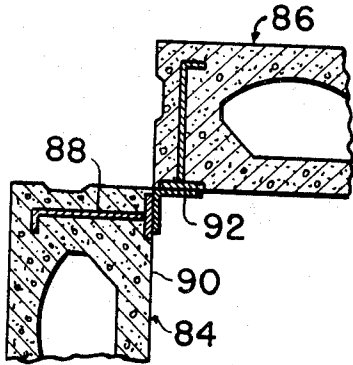

Fig. 8

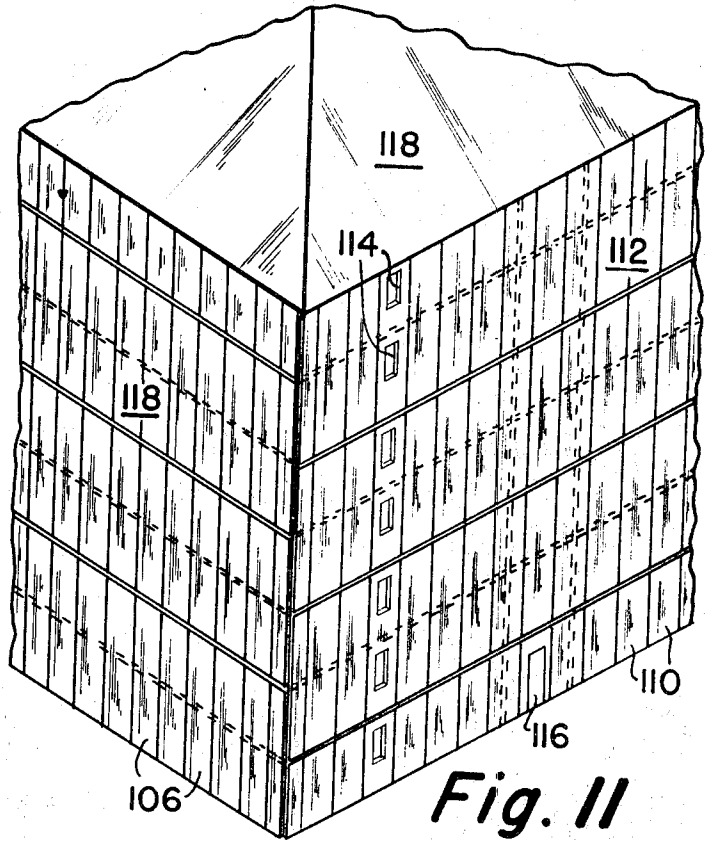

Fig. 11

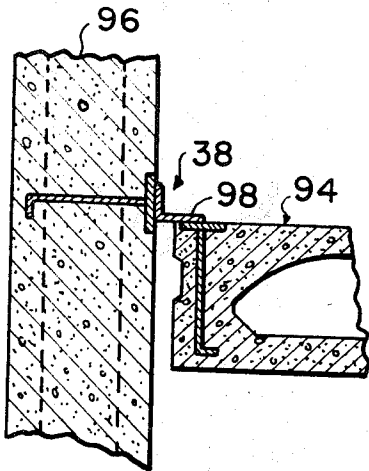

Fig. 9

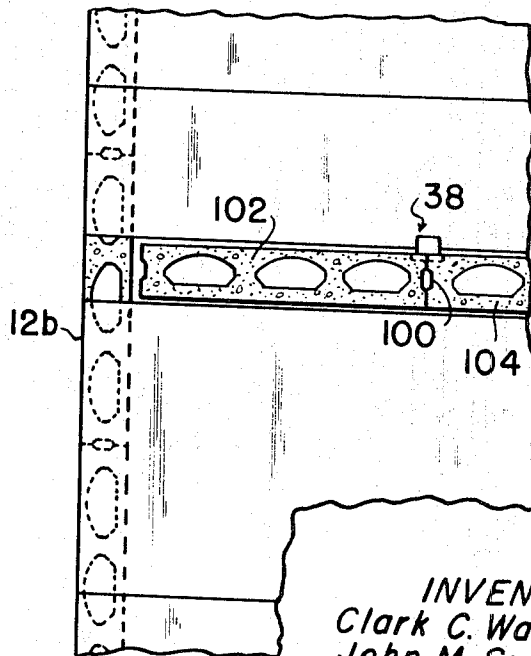

Fig. 10

BY

INVENTORS.
Clark C. Wallace
John M. Sweeney

Webb, Bunden, Robinson & Webb
THEIR ATTORNEYS

1

3,533,204

**PRECAST MULTISTORY BUILDING
CONSTRUCTION**

Clark C. Wallace, R.D. 1, Harmony, Pa. 16037, and
John M. Sweeney, 131 Sylvania Drive, Pittsburgh, Pa.
15236

Filed Dec. 5, 1968, Ser. No. 781,378

Int. Cl. E04b 1/04, 5/02

U.S. Cl. 52-236

6 Claims

ABSTRACT OF THE DISCLOSURE

A building construction for a multistory structure comprising an arrangement of vertical load-bearing and shear resistant walls supporting horizontal floors without the use of rigid moment connections therebetween. Alternate floors of the building are oriented at right angles to one another and each floor section is connected to a wall section other than one by which it is supported in a manner so as to resist horizontal forces applied to the structure. The floor planks used are preferably prestressed, precast unit; the wall units are precast but not prestressed.

This invention relates to a building construction and particularly to a construction for multiple story structures, such as apartment and office buildings. Precast units of predetermined dimensions are utilized in the construction, which is characterized by the absence of rigid moment connections in an entire structure using the system. Surprising economies are realized in erection and materials when the building construction is employed, and the construction has been found to be more stable, and particularly more resistant to shear forces than heretofore achieved.

We have invented a new building construction comprising an arrangement of precast vertical wall units supporting cast horizontal floor planks. The system is applicable to the construction of buildings having at least two floors or stories and is particularly useful for large buildings having, for example, twelve or more stories. The construction is unique in that in an entire building of such a size, no floor is rigidly connected to a wall supporting it in a manner so as to resist a moment or force applied normal to that wall at a height above ground level. Such force is resisted by wall units running perpendicular to such supporting wall units. A building employing our construction is self-supporting and internally resistant to moment forces as will be shown hereinafter.

Heretofore, modular units comprising rigidly connected floor and wall members have substantially reduced the cost of erecting buildings having standardized or uniform interior plans. By joining a plurality of such units, large buildings have been erected in less time, and with less on site labor, than had been possible theretofore. Yet, a substantial drawback to use of such units in constructing a building having plural stories has been the need to use rigid connections between the floor units and their supporting wall units to resist horizontal forces, such as those exerted by wind and earthquake, applied to the walls of the stories.

It is well known that such forces can be extremely large and that the effect of such forces increases as the distance of the point above ground level to which the force is applied increases. For example, a wind force acting on a point sixteen feet above ground (the top of a second story wall) exerts a load substantially less than the same wind force applied to a point on a wall ninety-six feet above ground (the top of a twelve story wall). Additionally, it is well understood that the load per square foot increases as the height of the structure increases. Accordingly, it is essential in building design to provide

2

a construction which is sufficiently strong to resist such forces and which is stable. In this connection, a structure using our construction includes wall sections which are self-supporting during erection; upon erection, the structure is more resistant to drift due to its internal rigidity and provides better occupant comfort than now obtained especially at great heights. Moreover, our construction is economical to erect and maintain.

Prior construction techniques recognized that it is necessary to transmit horizontal forces applied to a structure from the floors of the structure into the walls whereby they can be effectively resisted. Usually, these forces are transferred from a floor directly into a wall supporting such floor. Since a multiple story structure has several floors, it has been necessary to reinforce the base of the structure, at large expense of time and materials, where the shear forces are most severe since they are the summation of the forces applied to the upper stories of the building. In some cases, additional wall sections have been installed to resist these shear forces, but, since these added sections were non-bearing walls, they were not wholly effective and their use merely added significant costs to construction of the structure.

We have invented a building construction in which every wall in a structure using it is both a load bearing wall and shear resistant wall. Alternate floors of the structure are oriented perpendicular to one another. Each floor is supported by wall sections other than ones to which they are shear connected. Thus, our construction permits all horizontal forces to be transmitted from a floor section into a wall section other than the wall by which it is supported. In other words, all horizontal forces are resisted by means of a shear connection between a floor section and a wall section which supports the floor above. As used in this specification, it should be understood that the terms floor and ceiling are interchangeable, since the ceiling of one story is the same as the floor of the story above.

A precast system according to our invention is illustrated in the attached drawings in which:

FIG. 1 is an isometric, cut-away view of our building construction used in a multiple story structure;

FIG. 2 is an isometric view of a typical precast unit used as a wall unit or floor plank in our construction;

FIG. 3 is a section through a building footing showing an exterior wall section and its connection with floor planks of two stories;

FIG. 4 shows only the first floor of the multistory structure shown in FIG. 1, before the second story walls are erected;

FIG. 5 is a partial section through a wall showing the joint between it and adjacent floor sections;

FIG. 6 is a plan view of a building structure showing two floors of a structure constructed using our construction;

FIG. 7 is a sectional view showing an interior wall section supporting floor planks end-to-end at a bearing point, such as identified by chain circle VII in FIG. 6;

FIG. 8 is a cross-sectional, enlarged view of the wall corner connection in chain circle VIII of FIG. 6;

FIG. 9 is a sectional view through a typical shear connection between a vertical wall and a horizontal floor;

FIG. 10 is a plan view showing a T-joint between walls which is an enlargement of chain circle X in FIG. 6; and

FIG. 11 is a partial isometric, showing an exterior view of a structure incorporating our novel precast building construction.

Referring to FIG. 1, a four story section of a multiple story building including our invention illustrates the principles of our invention. The building section shown is supported on a concrete footing 10. Precast wall units 12 are erected vertically on the footing 10.

Although other types of precast units may be used in our invention, we prefer to use a precast unit of the typical type shown in FIG. 2. This unit comprises an elongated body 14 having edges 16 and ends 18. One standard size for such units is 4 feet wide x 8 feet long and 8 inches thick; a 16 foot length is also standard. A plurality of symmetrical longitudinal openings 20 are formed in the body substantially parallel to the edges 16. The purpose of the openings is to reduce the total weight of the body. Along the edges 16 of the body are longitudinal grooves 22, which, when two bodies, such as 14 and 14a (partially shown), are placed with their edges 16 adjacent one another, form a key groove 24 which may be filled with grouting or the like to retain the bodies in position edge-to-edge.

As shown in FIG. 3, each wall unit 12 is aligned with a portion of footing 10 and extends vertically above it. A metal reinforcing bar 26 is embedded in footing 10 and runs longitudinally through the wall unit 12 to position it securely. A part of floor plank 28 forming the floor of a second story is shown extending perpendicularly to the wall unit 12 and is secured to the unit 12 by a second reinforcing bar 30 which is bent at right angles. One end of the bar 30 is anchored in unit 12, the other end is secured to floor plank 28. A dowel 32 extends vertically from unit 12 into a wall unit 34 aligned with unit 12.

The longitudinal axis of a floor plank 36 forming a portion of the floor of the third story extends parallel to the plane of the wall of which unit 34 is a part. Floor plank 36 is perpendicularly oriented to floor plank 28 of the floor below it. A type of shear connection 38 to be described in detail with reference to FIGS. 9 and 10 joins plank 36 to a wall unit 34. Other types of shear connections between wall units and floor planks are also possible, for example grouting alone can be used where it is capable of transmitting the force applied to the connection. Uniformly throughout a structure using our construction, floor planks of alternate stories are disposed perpendicular to each other.

Again referring to FIG. 1, precast building units 12 are located on the footing 10 edge-to-edge to form a continuous wall extending from the footing a single story in height. A floor, comprised of a plurality of floor planks 28, is laid across the top edge of wall units 12 and supported by a similar set of wall units 12a (see FIG. 4) which extend vertically from a second footing (not shown) spaced from wall units 12 a distance substantially equal to the length of a floor plank 28. The entire portion of the first story construction shown in FIG. 1 is better illustrated in FIG. 4.

FIG. 4 shows the construction of a portion of a first story of a multistory building including vertical wall units 12, 12a and 12b which support second floor planks 28 and 28a. Floor planks 28 and 28a are positioned end-to-end such that their adjoining ends each are supported by substantially one half of the top edge of vertical wall unit 12a. Floor planks 28a are laid edge-to-edge across the top edges of wall units 12a and 12b forming the first story ceiling of the building and generally forming two large volumes A and B.

A second story is constructed, as shown in FIG. 1, by vertically inserting wall units 40 in longitudinal slots formed by spacing second floor planks 28a from each other a distance slightly greater than the thickness of a single wall unit 40. As shown, each wall unit 40 is approximately twice as long as the height of a single story of the multistory structure, and it extends upwardly to support the floor formed by floor planks 42 of a third story of the building. Although it is not necessary that each wall unit, such as 40, be two stories in length, each interior supporting vertical wall unit of our building construction should extend more than a single story. In other words, although the stories of the building need not be of the same height, it is necessary that the height

of shear resistant wall units be greater than a single story to permit the connection of an intermediate floor to those wall units.

Floor planks 42 extend across the top edges of adjacent wall units 40 and run perpendicular to the floor planks of the next vertically adjacent story. The floor planks 42 extend across a series of wall units 40 to rest on the top edge of a set of wall units (not shown) which run parallel to wall units 40. Thus, the spaced walls are formed of adjacent wall units running parallel to each other and perpendicular to floor planks which they support. This is clearly shown in FIG. 6 which compares two floors of a building utilizing our construction. The upper portion of the drawing shows a floor 44 which runs perpendicular to the next vertically adjacent floor 46 i.e. the one below it (illustrated in the lower half of the drawing). By orienting adjacent floors perpendicular to one another, vertical and horizontal force loads are distributed into all the walls.

The foregoing description outlines the basic features of our invention. The most significant feature of the invention is our provision of wall units which extend more than a single story and the positioning of such units in slots formed by spacing adjacent perpendicularly positioned floor planks forming the floor of a story above the base of such walls, such that each such vertical wall unit in the structure constitutes a bearing wall.

As is well known in the art, bearing walls resist shear stresses substantially better than do non-bearing walls. Thus, a structure utilizing our construction is comprised of all bearing walls which when connected to the floor units provide the structure with substantial resistance strength against forces, such as wind and earthquake forces, tending to create moments and shears apt to collapse the structure walls.

As shown in FIG. 1, additional wall units 48 of two story length may be positioned vertically in a longitudinal slot formed between perpendicularly positioned floor planks, for example, of the third story floor, shown at 50. Additional floors formed of floor planks 52 are supported by wall units 48 and 54 to form a fourth story of the structure. This construction features repetition of the method of erecting adjacent stories in that each floor runs perpendicular to the floor above and below it and is supported by wall units which extend a distance of at least greater than a story below it. Single story walls where required such as wall 56, are formed by connecting a series of precast units to the footing or floor of adjacent stories.

As shown in FIG. 4, a corridor may be formed adjacent the volumes A and B by spacing a pair of vertical wall units 12a from each other. Across the top of the corridor is a header 58 comprising an angle which is anchored to each unit 12a. After the header is positioned properly, floor planks 28b of the same or different width than planks 28 may be extended between vertical wall units 12b and the header 58 to form the corridor ceiling.

An important aspect of our construction, shown in FIG. 5, comprises the connections between the vertical wall units and the horizontal floor planks which adjoin one another in various arrangements throughout a building embodying our system. A wall unit 60 which is approximately two stories in length or about 16 feet long is supported on a floor (not shown) and extends through a slot 62 between two planks 64 and 66 forming a part of the next highest floor of the structure. The floor planks are attached to the wall by shear connections, which, for interior walls, may comprise simply grouting the solid space between the floor planks and wall unit to permit transfer of force from the planks into the wall. Another type of shear connection which may be used on interior walls and must be used for exterior wall sections includes an angle member as will be described in detail hereinafter with reference to FIGS. 9 and 10.

In FIG. 5, grouting 68 is applied in the spaces between

5

the wall unit and the floor planks to form a seal therebetween to vertically align the wall unit between the floor planks and to stabilize or make the structure rigid to minimize drift force. In some instances, it is necessary to align a wall unit, such as 60, by driving a wedge 70 between the edge of a plank 66 and the face of a wall unit 60. Slots formed by spaced floor planks are preferably about 10 inches wide and a wall unit, such as shown in FIG. 2, is typically 8 inches thick; therefore, approximately a one inch space remains to be filled with grout or other suitable material, if necessary, on each side of a wall unit.

An important connection is that which is made between an interior wall and the floor planks supported by that wall of the structure. Chain circle VII in FIG. 6 identifies the position of one such connection. As shown in FIG. 7, a pair of floor planks 72 and 74 are horizontally supported by a wall unit 76, the ends of the planks being slightly spaced apart. A wall unit 78 forming a part of the wall above the portion of the floor shown is vertically aligned with the lower wall unit and supported by the floor planks. To maintain this alignment, a dowell 80 is placed between the wall units. Metal reinforcing bars, one of which is shown at 82, are positioned in the aligned key grooves of the floor planks. The entire connection is then grouted solid.

The connection at the corner of the structure between exterior walls, such as 84 and 86, and shown in the chain link circle identified as VIII in FIG. 6, is enlarged in FIG. 8. Two perpendicularly oriented precast reinforced concrete units (of the type shown in FIG. 2) are joined corner to corner as, for example, at the corner of a building. Embedded in each of the precast units is a metal anchor bar 88 having a base plate which is flush with a face 90 of the unit. To attach the two units together, an L-angle 92 is positioned between them such that the flanges of the angle mate with the base plates of the anchor bars of the precast units. The angle is then welded or otherwise suitably attached to the bars.

A typical shear connection between an exterior wall unit and a floor plank is shown in FIG. 9. Substantially the same type of angle construction is used in this connection; however, the function of this connection is to transmit horizontal force from a floor section 94 into a wall section 96 joined by an angle 98. The shear connections between floor planks and wall units in our construction are made between a floor plank and a wall unit other than a wall unit which supports such floor plank. In this manner, any horizontal force applied to such floor plank is transmitted to a bearing wall for effective shear resistance.

In FIG. 10, the shear connection in the chain link circle X of FIG. 6, between two wall units and a floor plank, is shown in plan view. Key groove 100 between two adjacent precast units 102, 104 can be grouted. Such shear connection may be spaced as shown between two precast units along an entire wall, the number of such connections being a function of the magnitude of the horizontal shear force on the structure at the particular floor height under consideration.

The exterior of a structure employing our construction is shown in FIG. 11. Viewed from a corner of the structure, the relative position of wall units 106 forming wall 108 and wall units 110 forming wall 112 is clearly apparent. Windows 114 may be appropriately located in place of any of the units 106 and 110. Doors 116 may be similarly located for entrances or balconies as desired. A roof 118 completes the structure.

Our building construction permits economical erection of a multiple story structure using standard precast concrete reinforced, prestressed and non-prestressed units. Substantially dimensionally identical units may be used as the floor plank and wall units. We prefer that only those units used as floor planks be prestressed.

By using standardized materials as wall units and floor

6

planks, it is possible to design, quickly and economically, an entire building having uniform features. As shown heretofore, by eliminating one or more units or using less than an entire unit, it is possible to provide space for doors, windows, and the like in the structure.

More significantly, however, is our discovery that it is possible to construct a structure having no rigid moment connections and all load bearing and shear resistant walls, and to obtain true design versatility without sacrificing stability of structure. Our new building construction, to our knowledge, meets all professional and governmental standards for structures of the type disclosed.

Having disclosed a preferred embodiment of our invention, it is to be understood that it may be otherwise embodied in the scope of the appended claims.

1. A building construction for a multiple story structure comprising:

- (a) at least three vertically spaced floors;
- (b) at least a first wall section vertically supported at one end by one of the floors and the other end supporting a part of another of the floors;
- (c) at least a second wall section vertically positioned in a plane perpendicular to the plane of said first wall section; and
- (d) a floor between the supporting and supported floors connected to the first wall section intermediate its ends so as to resist transverse force through the intermediate floors by transmitting it to the first wall section and bearing on an end of said second wall section on which it is supported.

2. A building construction as set forth in claim 1 in which each wall section in the structure is a load bearing member and is connected to and supports at least a floor forming the ceiling of a story other than the story having the floor on which the wall is supported.

3. A building construction as set forth in claim 1 in which each floor comprises a plurality of precast floor planks and each wall section comprises a plurality of precast wall units.

4. A building construction as set forth in claim 2 in which:

- (a) at least two of the floor planks forming part of a floor are spaced apart from each other to form a slot having a width slightly greater than the thickness of a wall section adapted to be placed into the slot;
- (b) a wall section extending vertically through the slot to rest on a floor therebelow; and
- (c) means for connecting one or both of the spaced apart floor planks to said wall section.

5. A building construction for a multiple story structure comprising:

- (a) at least three vertically spaced floors each of which floors comprises a plurality of floor planks;
- (b) at least a wall section comprising a plurality of precast wall units vertically supported at one end by one of the floors and the other end supporting a part of another of the floors;
- (c) a floor comprising a plurality of floor planks between the supporting and supported floors and connected to the wall section intermediate its ends so as to resist transverse force through the intermediate floor by transmitting it to the wall section; and
- (d) the longitudinal axis of each floor plank forming part of any floor extending substantially perpendicular to the longitudinal axis of each floor plank forming a part of either a floor above or a floor below such floor.

6. A building construction for a multiple story building in which there are a plurality of floors and a plurality of walls supporting and being supported by the floors comprising:

- (a) at least three vertically spaced floors;
- (b) at least a wall section vertically supported at one

7

- end by one of the floors and the other end supporting a part of another of the floors;
- (c) a floor between the supporting and supported floors and connected to the wall section intermediate its ends so as to resist transverse force through the intermediate floor by transmitting it to the wall section;
- (d) each of the floors being formed of floor planks positioned edge-to-edge;
- (e) each of the walls being formed by wall units located edge-to-edge;
- (f) alternate floors of the structure having their floor planks oriented such that the length of the planks in one of the floors extends substantially perpendicular to the length of the planks in the other of the alternate floors; and
- (g) each wall section is supported by a floor in which the longitudinal axes of the floor planks forming the

8

floor are perpendicular to the plane of the wall section.

References Cited

UNITED STATES PATENTS

5	2,057,444	10/1936	O'Reilly	-----	52—236
	2,497,887	2/1950	Hilpert	-----	52—236
	3,304,675	2/1967	Wood	-----	521—745 X

OTHER REFERENCES

- 10 German printed application 1,059,170, June 11, 1959, Dieg.

JOHN E. MURTAGH, Primary Examiner

- 15 U.S. Cl. X.R.

52—250, 264, 270