



INTERNATIONAL APPLICATION PUBLISHED UNDER THE PATENT COOPERATION TREATY (PCT)

(51) International Patent Classification ⁶ : A61F 13/02	A1	(11) International Publication Number: WO 97/07760 (43) International Publication Date: 6 March 1997 (06.03.97)
<p>(21) International Application Number: PCT/GB96/02126</p> <p>(22) International Filing Date: 30 August 1996 (30.08.96)</p> <p>(30) Priority Data: 9517720.0 31 August 1995 (31.08.95) GB</p> <p>(71) Applicant (for all designated States except US): INNOVATIVE TECHNOLOGIES LIMITED [GB/GB]; Road Three, Winsford Industrial Estate, Winsford, Cheshire CW7 3PD (GB).</p> <p>(72) Inventors; and (75) Inventors/Applicants (for US only): GILDING, Keith, Denis [GB/GB]; Nepenthe, Winsford Road, Wettenhall, Winsford, Cheshire CW7 4DL (GB). BRENWALL, Ronald, Eugene [US/GB]; 1 Saint Vincent Drive, Hartford, Cheshire CW8 2FT (GB).</p> <p>(74) Agent: ATKINSON, Peter, Birch; Marks & Clerk, Sussex House, 83-85 Mosley Street, Manchester M2 3LG (GB).</p>	<p>(81) Designated States: AL, AM, AT, AU, AZ, BB, BG, BR, BY, CA, CH, CN, CU, CZ, DE, DK, EE, ES, FI, GB, GE, HU, IL, IS, JP, KE, KG, KP, KR, KZ, LC, LK, LR, LS, LT, LU, LV, MD, MG, MK, MN, MW, MX, NO, NZ, PL, PT, RO, RU, SD, SE, SG, SI, SK, TJ, TM, TR, TT, UA, UG, US, UZ, VN, ARIPO patent (KE, LS, MW, SD, SZ, UG), Eurasian patent (AM, AZ, BY, KG, KZ, MD, RU, TJ, TM), European patent (AT, BE, CH, DE, DK, ES, FI, FR, GB, GR, IE, IT, LU, MC, NL, PT, SE), OAPI patent (BF, BJ, CF, CG, CI, CM, GA, GN, ML, MR, NE, SN, TD, TG).</p> <p>Published <i>With international search report.</i> <i>Before the expiration of the time limit for amending the claims and to be republished in the event of the receipt of amendments.</i></p>	

(54) Title: FILM DELIVERY ASSEMBLY

(57) Abstract

A film delivery assembly (for use in applying the film to a wound) comprises (a) a thin conformable film (2) having first and second surfaces, and (b) a first releasable carrier (5) attached to the first surface of the film. The first carrier (5) comprises two opposed handle portions (6) provided at opposed sides of the first surface and each being integral with a spine arrangement (7) extending between the handles inwardly of the edges of the film (2).

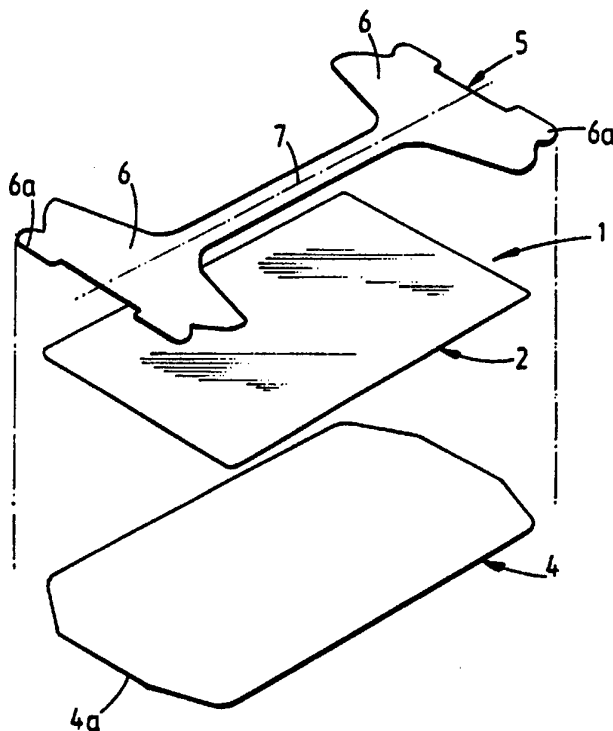

FOR THE PURPOSES OF INFORMATION ONLY

Codes used to identify States party to the PCT on the front pages of pamphlets publishing international applications under the PCT.

AM	Armenia	GB	United Kingdom	MW	Malawi
AT	Austria	GE	Georgia	MX	Mexico
AU	Australia	GN	Guinea	NE	Niger
BB	Barbados	GR	Greece	NL	Netherlands
BE	Belgium	HU	Hungary	NO	Norway
BF	Burkina Faso	IE	Ireland	NZ	New Zealand
BG	Bulgaria	IT	Italy	PL	Poland
BJ	Benin	JP	Japan	PT	Portugal
BR	Brazil	KE	Kenya	RO	Romania
BY	Belarus	KG	Kyrgystan	RU	Russian Federation
CA	Canada	KP	Democratic People's Republic of Korea	SD	Sudan
CF	Central African Republic	KR	Republic of Korea	SE	Sweden
CG	Congo	KZ	Kazakhstan	SG	Singapore
CH	Switzerland	LI	Liechtenstein	SI	Slovenia
CI	Côte d'Ivoire	LK	Sri Lanka	SK	Slovakia
CM	Cameroon	LR	Liberia	SN	Senegal
CN	China	LT	Lithuania	SZ	Swaziland
CS	Czechoslovakia	LU	Luxembourg	TD	Chad
CZ	Czech Republic	LV	Latvia	TG	Togo
DE	Germany	MC	Monaco	TJ	Tajikistan
DK	Denmark	MD	Republic of Moldova	TT	Trinidad and Tobago
EE	Estonia	MG	Madagascar	UA	Ukraine
ES	Spain	ML	Mali	UG	Uganda
FI	Finland	MN	Mongolia	US	United States of America
FR	France	MR	Mauritania	UZ	Uzbekistan
GA	Gabon			VN	Viet Nam

FILM DELIVERY ASSEMBLY

The present invention relates to a film delivery assembly for use in medical applications. The invention relates more particularly to such an assembly incorporating a thin conformable film which is provided on one surface with an adhesive and which is to be applied to the body of a patient and adhered in position by the adhesive.

This conformable films are used for a number of medical applications, e.g. as a wound dressing or for locating a medical device in position on the body of a patient. Examples of such films are the moisture transmission films available from Innovative Technologies Limited under the designations IT325, IT425 and IT625. Films are also available from other manufacturers.

In view of their thin conformable nature, it is very difficult (if not impossible) satisfactorily to apply such films in an unsupported condition to the body of the patient. This is because the film may tend to wrinkle and adhere to itself by virtue of the adhesive on the film. It is therefore generally the case that, as supplied, the film is sandwiched between two supporting layers, namely a first releasable carrier attached to the adhesive side (the "second surface") of the film and a first releasable carrier attached to the other side (the "first surface") of the film. The first carrier (whilst still being releasable from the film) is attached more tenaciously to the film than is the second carrier.

To apply the film to the body of a patient, the second carrier is initially removed so as to leave the film supported in a wrinkle free condition by the first carrier. The adhesive side of the film may then be located in the position of the body of the patient and the first carrier subsequently removed. Thus the film is supported throughout the application.

Whilst it is possible for the first carrier to be continuous over the film, this may not be desirable because it is then not possible to see through the film (which will generally be transparent) to ensure accurate location of the film in position, e.g. on a wound.

EP-A-0051935 (Minnesota Mining and Manufacturing Company) discloses a film delivery assembly of the type discussed above in which the first carrier is a quadrilateral shaped frame provided around the peripheral edges of the outer side of the film thus providing a central viewing area through the film. The assembly of EP-A-0051935 does however suffer from the disadvantage that (during application of the film) the peripheral frame reduces the conformability of the film around the edges thereof. This is a particular disadvantage when the film is to be located around or over an IV tube or the like.

According to the present invention there is provided a film delivery assembly comprising

- (a) a thin conformable film having first and second surfaces, and
- (b) a first releasable carrier attached to the first surface of the film

wherein the first carrier comprises two opposed handle portions provided at opposed sides of the first surface and each being integral with a spine arrangement extending between the handles inwardly of the edges of the film.

In the assembly of the invention, the film is held in a wrinkle free condition by virtue of the arrangement of the handles and the connecting spine arrangement. The peripheral edges of the film which extend parallel to the spine arrangement are not overlaid by the carrier and their conformability is not hindered by the second carrier.

Preferably the spine arrangement is provided centrally across the film. The spine may be generally linear or may have a non-linear formation intermediate its ends. This formation may, for example, be of a shape (such as a letter) representing the manufacturer/supplier of the delivery assembly.

For preference the first carrier is a one-piece component comprising the two spaced handle portions and the spine arrangement whereby the carrier may be removed in one piece once the film has been applied to the body of a patient. However we do not preclude the possibility that the carrier is provided in two pieces each of which comprises one of the handle portions and a portion of the spine arrangement. In such a case, the discontinuity in the spine arrangement of the carrier should be very small so that there is no substantial gap between adjacent ends of the spine arrangement.

For preference the carrier is of generally H-shaped configuration.

Preferably also the film is generally square or rectangular with the handles extending entirely along or partially overlying opposed peripheral edges of the films. It is convenient that the handles partially overlies the peripheral edges of the film as the "overhangs" provide areas by means of which the handles may be gripped between the fingers of a person applying the film.

The second surface of the film will generally be provided with an adhesive by means of which the film may be adhered to the body of a patient. In this case, it is preferred that the second surface of the film is associated with a second releasable carrier attached to the second surface less tenaciously than the first carrier is associated with the first surface of the film.

The second releasable carrier may comprise a single sheet of material. Alternatively this carrier may be provided in two parts each of which is divided by a

fold line into a cover portion and a flap portion. In this case, the two parts of the carrier may be positioned such that their respective cover portions together cover the entire area of the film with their fold lines adjacent and parallel to each other such that their flaps are located on the side of the carrier parts opposite to the film. Each of the flaps may then be used for removing the respective carrier part from the film.

The film is preferably a breathable film which is of increased MVTR capability in the presence of liquid water as compared to moisture vapour only. MVTR in the presence of liquid water may be measured by ASTM E96BW whereas MVTR in the presence of moisture vapour alone may be measured by ASTM E96B (water method). Preferably the value of the breathability in the presence of liquid water is at least twice and preferably at least three times that in the presence of moisture vapour alone. The values may be up to 10 or 20 times that for moisture vapour alone. Typically the film will be of a material which has an MVTR in the presence of moisture vapour alone (ASTM E96B) of 1,000 to 5,000 $\text{g m}^{-2} 24\text{hr}^{-1}$ and an MVTR in the presence of liquid water (ASTM E96BW) in the range of 3,000 to 30,000 g m^{-2} (e.g. 6,000 to 10,000 $\text{g m}^{-2} 24\text{hr}^{-1}$). Typically the film will have a thickness of 30-70 microns more preferably 40-60 microns, e.g. about 50 microns.

The film may for example be of polyurethane. Suitable films are available from Innovative Technologies Limited under the designations B53-2, C54-2 and D56-2.

The adhesive (if present) on the second surface of the film may be provided as a continuous or discontinuous pattern to give any desired coverage up to 100%. The adhesive is preferably a hydroactive adhesive most preferably one which, as a continuous layer having a thickness of 20 microns, has an MVTR of 15,000 $\text{g m}^{-2} 24\text{hr}^{-1}$. Preferably the combination of the adhesive and film is such as to provide an MVTR of 6,000 to 10,000 $\text{g m}^{-2} 24\text{hr}^{-1}$.

The hydroactive adhesive may be provided as a continuous layer on the film. The adhesive is preferably applied in an amount of 2 to 40 g m⁻² of the film.

Alternatively the adhesive may be a pressure sensitive adhesive provided as a cross-pattern to achieve 20-50% area coverage and to achieve similar MVTRs for the combination of adhesive and film of 6,000 to 10,000 g m⁻² 24 hr⁻¹.

Examples of suitable adhesive are those available from Innovative Technologies under the designations IT PSA HT or PSA LT.

The invention will be further described by way of example and with reference to the accompanying drawings, in which

Fig 1 is an exploded perspective view of a first embodiment of film delivery assembly in accordance with the invention;

Fig 2 is plan view of the assembly of Fig 1;

Fig 3 is a section of the line III - III of the assembly of Fig 1; and

Fig 4 is an exploded perspective view of a second embodiment of film delivery assembly in accordance with the invention.

Referring to the drawings, a film delivery assembly 1 comprises a thin, conformable film 2 having a lower surface provided with adhesive 3 (see insert to Fig 3). The assembly further incorporates a carrier 4 (e.g. paper or card) attached to the adhesive 3 and a generally H-shaped carrier 5 (e.g. paper or card) attached to the upper surface of the film more tenaciously than carrier 4 is attached to the adhesive 3.

As shown, the film 2 is generally rectangular with rounded corners. Carrier 4 is of the same width as film 2 but is overall of greater length and is shaped at its end to provide generally trapezoidal overhangs 4a extending beyond the widthwise edges of film 2.

As mentioned, carrier 5 is generally H-shaped and incorporates two handle portions 6 connected by a spine arrangement 7. Each of the handle portions 6 overlies a respective widthwise edge of film 2 so as to provide overhang portions of flaps 6a by means of which the handle portions may be gripped. As shown, the overhangs 6a of carrier 5 extend beyond the overhang portions 4a of carrier 4.

To apply the film, carrier 4 is firstly removed. The carrier 5, with supported film 2, may now be held by it gripping the overhanging portions 6a of the handle portions 6. The adhesive side of the film is located in position on the patient, this operation being facilitated by the fact that a substantial area of the transparent film is exposed through which the target area on the body is visible. During applications, the film is maintained in a wrinkle free condition by the carrier 5 which is then removed and discarded after the application of the film.

The film may be used as a wound dressing or for locating a medical device in position on the body of a patient. In the latter case, the film may be provided with a cut out (such as illustrated at 8, by the dashed lines) for location around the device.

Reference is now made to Fig. 4 which illustrates a further embodiment of film delivery assembly in accordance with the invention. The assembly of Fig. 4 is in many respects similar to that of Fig. 1 and therefore like parts in these two drawings are represented by the same reference numerals. Only the differences between the two constructions will be described.

In the assembly of Fig. 4, the spine represented by the reference numeral 17 incorporates, intermediate its ends, a non-linear formation 18 (generally as illustrated in the form of the letter C) which may be used as an indication of the manufacturer/supplier of the assembly.

Furthermore, in the assembly of Fig. 4, the single sheet carrier 4 of Fig. 1 is replaced by two carrier parts 20 each of which is sub-divided by a fold line 21 into a cover portion 22 and a flap 23. The two cover portions 22 together cover the entire area of the film 2 such that the fold lines 21 are in juxtaposed parallel relationship. The two flaps 23 are in face-to-face relationship and may be folded flat against one of the cover portions 22 (as represented by the arrows) for the purposes of packaging the dressing. Each carrier part 20 may be removed from the film by gripping its respective flap 23 and pulling to remove the associated carrier part from the film.

CLAIMS

1. A film delivery assembly comprising
 - (a) a thin conformable film having first and second surfaces, and
 - (b) a first releasable carrier attached to the first surface of the filmwherein the first carrier comprises two opposed handle portions provided at opposed sides of the first surface and each being integral with a spine arrangement extending between the handles inwardly of the edges of the film.
2. An assembly as claimed in Claim 1 wherein the spine arrangement is provided centrally across the film.
3. An assembly as claimed in Claim 1 or 2 wherein the second carrier is a one-piece component comprising the two handle portion and the spine arrangement.
4. An assembly as claimed in any one of claims 1 to 3 wherein the spine arrangement has a non-linear formation intermediate its ends.
5. An assembly as claimed in any one of claims 1-4 wherein the second carrier is of generally H-shaped configuration.
6. An assembly as claimed in any one of claims 1-5 wherein the film is generally square or rectangular and the handles extend entirely along or partially overlie opposed peripheral edges of the film.

7. An assembly as claimed in any one of claims 1 to 6 wherein the handles partially overlie the peripheral edges of the film.
8. An assembly as claimed in any one of claims 1 to 7 wherein the second surface of the film is provided with an adhesive by means of which the film may be adhered to the body of a patient.
9. An assembly as claimed in claim 8 wherein the second surface is associated with a second releasable carrier attached to the second surface less tenaciously than the first carrier is associated with the first surface of the film.
10. An assembly as claimed in claim 9 wherein the second carrier is a single sheet of material.
11. An assembly as claimed in claim 9 wherein the second carrier is provided in two parts each of which is divided by a fold line into a cover portion and a flap portion, the two carrier parts being positioned such that their respective cover portions together cover the entire area of the film with their fold lines adjacent and parallel to each other and their flaps are located on the side of the carrier parts opposite to the film.
12. An assembly as claimed in any one of claims 1-11 wherein the film is a breathable film which is of increased MVTR capability in the presence of liquid water as compared to moisture vapour only.
13. An assembly as claimed in any one of claims 1-12 wherein the film has a thickness of 30-70 microns.

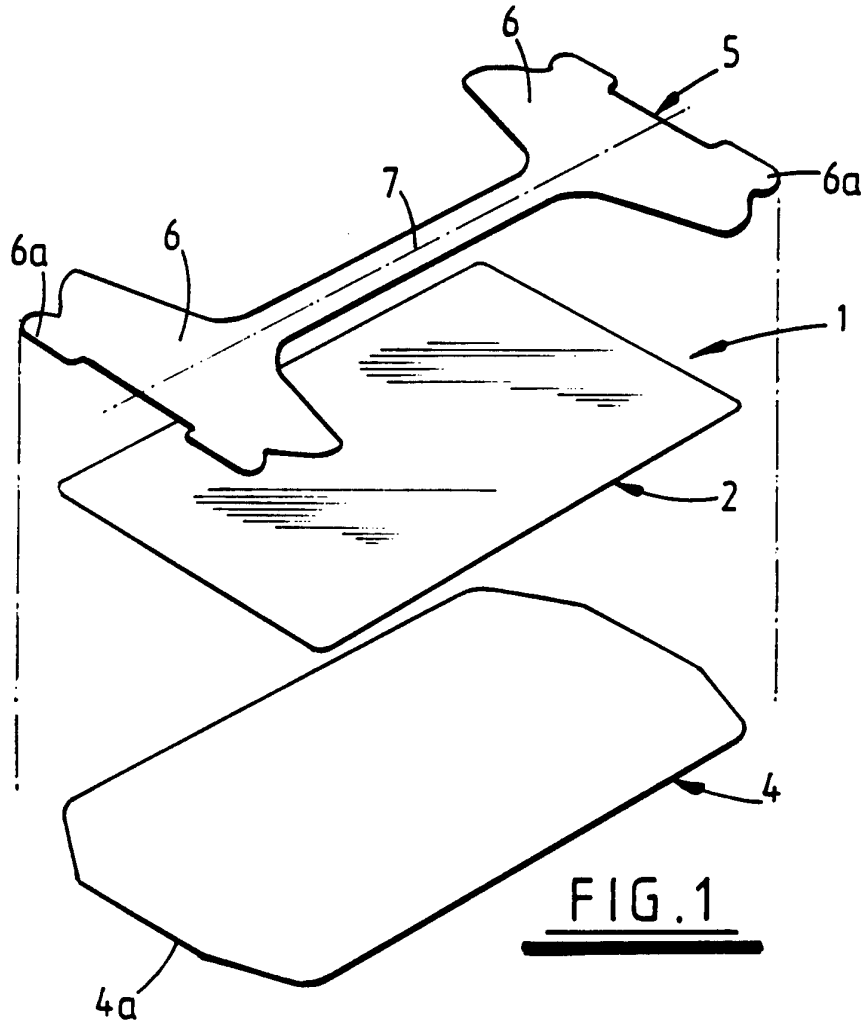

FIG. 1

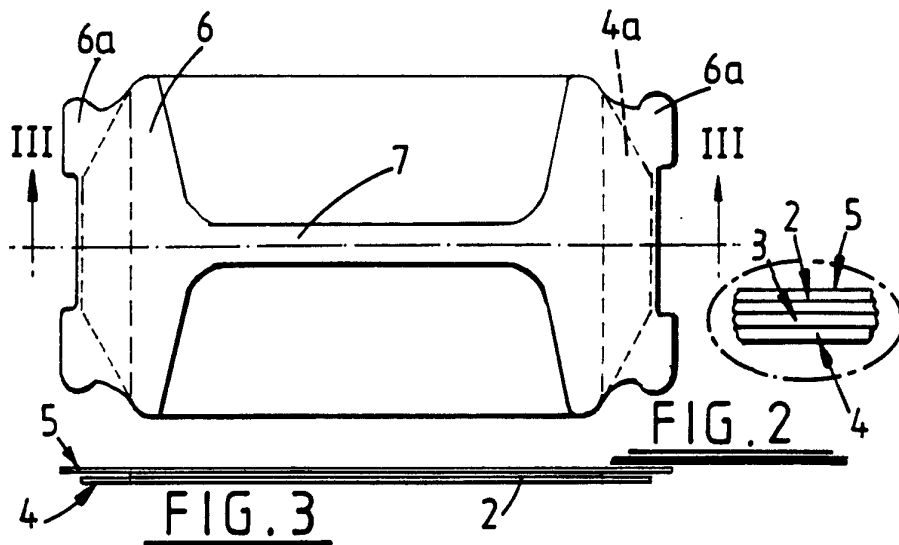

FIG. 2



FIG. 3

2-2

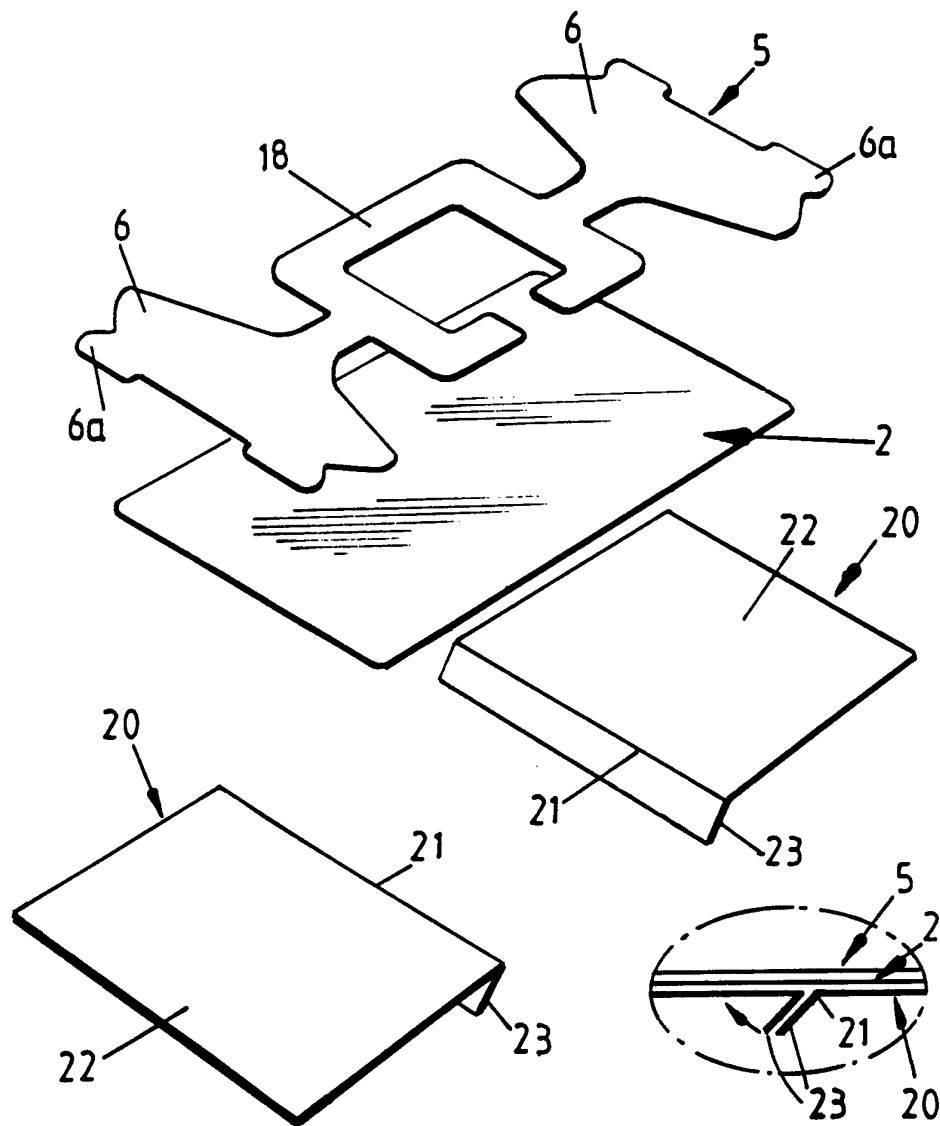

FIG. 4

INTERNATIONAL SEARCH REPORT

International Application No
PCT/GB 96/02126

A. CLASSIFICATION OF SUBJECT MATTER
IPC 6 A61F13/02

According to International Patent Classification (IPC) or to both national classification and IPC

B. FIELDS SEARCHED

Minimum documentation searched (classification system followed by classification symbols)

IPC 6 A61F B44C B65C G09F

Documentation searched other than minimum documentation to the extent that such documents are included in the fields searched

Electronic data base consulted during the international search (name of data base and, where practical, search terms used)

C. DOCUMENTS CONSIDERED TO BE RELEVANT

Category *	Citation of document, with indication, where appropriate, of the relevant passages	Relevant to claim No.
A	WO 94 21207 A (MINNESOTA MINING AND MANUFACTURING) 29 September 1994 see page 13, line 25 - line 31; figure 1 ---	1,3,4, 6-10
A	GB 2 131 299 A (SMITH AND NEPHEW) 20 June 1984 see page 3, line 121 - page 4, line 25 see page 4, line 33 - line 42; figures 1,3,4 ---	1,8,9, 11,13
A	EP 0 091 800 A (SMITH AND NEPHEW) 19 October 1983 see claims 1,4 ---	12,13
A	EP 0 638 301 A (BRISTOL-MYERS SQUIBB) 15 February 1995 see column 1, line 48 - column 2, line 26 -----	

Further documents are listed in the continuation of box C.

Patent family members are listed in annex.

* Special categories of cited documents :

- *A* document defining the general state of the art which is not considered to be of particular relevance
- *E* earlier document but published on or after the international filing date
- *L* document which may throw doubts on priority claim(s) or which is cited to establish the publication date of another citation or other special reason (as specified)
- *O* document referring to an oral disclosure, use, exhibition or other means
- *P* document published prior to the international filing date but later than the priority date claimed

- *T* later document published after the international filing date or priority date and not in conflict with the application but cited to understand the principle or theory underlying the invention
- *X* document of particular relevance; the claimed invention cannot be considered novel or cannot be considered to involve an inventive step when the document is taken alone
- *Y* document of particular relevance; the claimed invention cannot be considered to involve an inventive step when the document is combined with one or more other such documents, such combination being obvious to a person skilled in the art.
- *&* document member of the same patent family

Date of the actual completion of the international search

18 December 1996

Date of mailing of the international search report

27. 12. 96

Name and mailing address of the ISA

European Patent Office, P.B. 5818 Patentlaan 2
NL - 2280 HV Rijswijk
Tel. (+ 31-70) 340-2040, Tx. 31 651 epo nl,
Fax (+ 31-70) 340-3016

Authorized officer

Nice, P

INTERNATIONAL SEARCH REPORT

Information on patent family members

International Application No

PCT/GB 96/02126

Patent document cited in search report	Publication date	Patent family member(s)	Publication date
WO-A-9421207	29-09-94	AU-A- 6237494	11-10-94
		BR-A- 9405902	26-12-95
		CA-A- 2157040	29-09-94
		CN-A- 1121309	24-04-96
		EP-A- 0690706	10-01-96
		JP-T- 8508417	10-09-96
		US-A- 5531855	02-07-96

GB-A-2131299	20-06-84	AU-B- 569045	21-01-88
		AU-A- 2025483	03-05-84
		AU-B- 563489	09-07-87
		AU-A- 2025583	03-05-84
		CA-A- 1222671	09-06-87
		CA-A- 1222672	09-06-87
		GB-A- 2128479	02-05-84

EP-A-0091800	19-10-83	AU-B- 560088	26-03-87
		AU-A- 1379383	04-11-83
		WO-A- 8303549	27-10-83
		JP-B- 2061257	19-12-90
		JP-T- 59500698	26-04-84
		US-A- 4595001	17-06-86
		US-A- 4747401	31-05-88

EP-A-0638301	15-02-95	AU-A- 6751894	02-02-95
		CA-A- 2127173	21-01-95
		JP-A- 7067911	14-03-95
		ZA-A- 9405155	24-02-95
