

(19) World Intellectual Property
Organization
International Bureau



(43) International Publication Date
29 April 2004 (29.04.2004)

PCT

(10) International Publication Number
WO 2004/034906 A1

- (51) International Patent Classification⁷: **A61B 5/22**
- (21) International Application Number:
PCT/NL2003/000697
- (22) International Filing Date: 15 October 2003 (15.10.2003)
- (25) Filing Language: Dutch
- (26) Publication Language: English
- (30) Priority Data:
1021653 15 October 2002 (15.10.2002) NL
- (71) Applicant (for all designated States except US): **SMART-SENSE B.V.** [NL/NL]; Kapittelweg 16, NL-4827 HG Breda (NL).
- (71) Applicant and
(72) Inventor: **KRULLAARDS, Robert, Leonard** [NL/NL]; Voorburgseweg 70, NL-2264 AH Leidschendam (NL).
- (74) Agent: **VAN WESTENBRUGGE, Andries et al.**; Nederlandsch Octrooibureau, Scheveningseweg 82, P.O. Box 29720, NL-2502 LS The Hague (NL).
- (81) Designated States (national): AE, AG, AL, AM, AT, AU, AZ, BA, BB, BG, BR, BY, BZ, CA, CH, CN, CO, CR, CU, CZ, DE, DK, DM, DZ, EC, EE, EG, ES, FI, GB, GD, GE, GH, GM, HR, HU, ID, IL, IN, IS, JP, KE, KG, KP, KR, KZ, LC, LK, LR, LS, LT, LU, LV, MA, MD, MG, MK, MN, MW, MX, MZ, NI, NO, NZ, OM, PG, PH, PL, PT, RO, RU, SC, SD, SE, SG, SK, SL, SY, TJ, TM, TN, TR, TT, TZ, UA, UG, US, UZ, VC, VN, YU, ZA, ZM, ZW.
- (84) Designated States (regional): ARIPO patent (GH, GM, KE, LS, MW, MZ, SD, SL, SZ, TZ, UG, ZM, ZW), Eurasian patent (AM, AZ, BY, KG, KZ, MD, RU, TJ, TM), European patent (AT, BE, BG, CH, CY, CZ, DE, DK, EE, ES, FI, FR, GB, GR, HU, IE, IT, LU, MC, NL, PT, RO, SE, SI, SK, TR), OAPI patent (BF, BJ, CF, CG, CI, CM, GA, GN, GQ, GW, ML, MR, NE, SN, TD, TG).
- Published:
— with international search report
- For two-letter codes and other abbreviations, refer to the "Guidance Notes on Codes and Abbreviations" appearing at the beginning of each regular issue of the PCT Gazette.

(54) Title: TRAINING APPARATUS

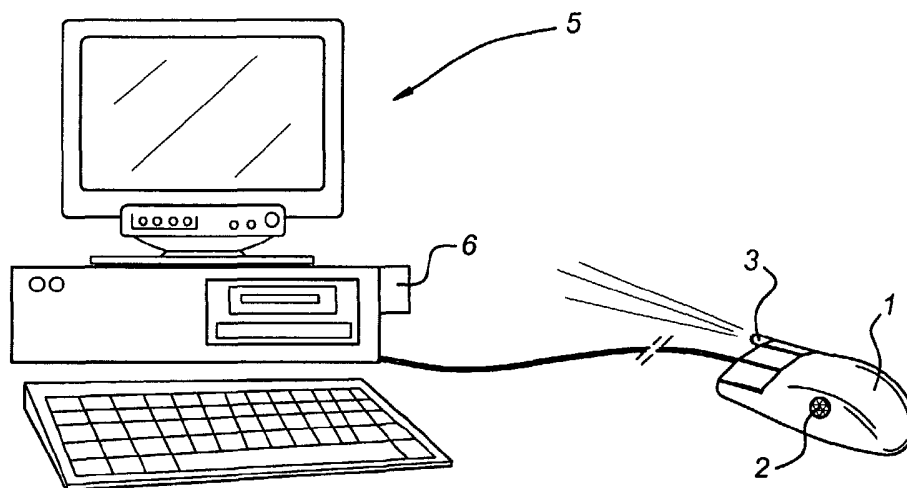

(57) Abstract: Device for detecting a pressure force exerted by a human muscle. If a sensor measures that a defined force is exceeded, a signal is emitted. This signal is used to indicate to the relevant person that he needs to modify his behavior. To determine the teaching effect of this signal, it is proposed for these signals to be stored in a memory and for the stored values to be read out after a certain time and compared with more recent signals. The device can be used, inter alia, in a writing instrument which measures both the gripping force on the writing instrument and the writing pressure.

WO 2004/034906 A1

TRAINING APPARATUS

The present invention relates to a device in accordance with the preamble of claim 1.

5 A device of this type is known from US 5,429,140. This document describes a glove having sensors which generate signals which are transmitted to a computer. All the signals from the sensors are stored and processed in the computer.

10 WO 0145561A1 (Tensor B.V./Smart Sense B.V.) describes a writing instrument provided with a squeezing force sensor. In the event of a defined squeezing force being exceeded, a signal is emitted. It has been found that the application of an excessive squeezing force impedes the circulation of blood in the shoulder area of the person who is writing, which can lead to complaints which can ultimately result in RSI-like symptoms.

15

It has been found that a pen of this type works particularly well and therefore positive results can be obtained particularly quickly. By adjusting the threshold value at which a signal is emitted, it is possible to gradually shift toward the desired state, certainly in the event of serious deviations.

20

However, in practice it has not proven easy to achieve such a state in targeted fashion.

The object of the present invention is to avoid this drawback and to provide a training device with which it is also possible to provide correction in the long term.

25

Moreover, it is an object of the present invention to provide a device which can be of compact structure and can be optimally controlled on the basis of a limited amount of data.

30 In a device of the type described above, this object is achieved by means of the characterizing clause and features of claim 1.

According to the present invention, the signals emanating from the force sensor are

stored in some way. During subsequent use, these signals are either read out and can then be compared with the current signals or are compared directly with the current signals. The effect and/or progress of improvement of the patient in question can be determined on the basis of this comparison, and any further measures required can be taken. Such measures may include, inter alia, altering the threshold value at which the force sensor becomes active in a specific way. According to the present invention, only those signals which exceed a defined threshold are stored. In this case, the exceeding of the threshold comprises at least the exceeding of a defined force, such as a squeezing force associated with a writing pressure of greater than 50-150 g. Moreover, according to a preferred embodiment, the threshold value can only be exceeded after a certain time delay, i.e. even if the abovementioned absolute value is exceeded, recording only takes place after this force has been present for a prolonged period, such as for example a few seconds. The latter parameter is dependent on the particular use of the device. This results in more than just recording of the forces. After all, the present invention only records "undesirable" behavior, and action can be taken on the basis of such behavior. This can ultimately lead to improved behavior on the part of the user, which manifests itself in particular in a reduction in the deep neck muscle tension. In this way, it is possible to prevent RSI-like phenomena.

According to an advantageous embodiment, the force sensor is designed in such a manner that in the event of continuous application of a force which exceeds the threshold value, warning signals are emitted regularly.

According to an advantageous embodiment of the invention, the force sensor is incorporated in an implement. If this implement is relatively small, it may be expedient for the above-described memory and readout/comparison device to be arranged separately therefrom. For example, it is possible for the relevant signals to be stored, for example wirelessly, from an implement to a PC. Of course, it is also possible, in the case of relatively large objects, for at least the memory to be arranged therein.

With the present invention, it is possible to use a series of signals emitted during a single operation to ascertain information about the behavior of the user, i.e. it is possible to draw a distinction between brief and prolonged (incorrect) operation of an

implement.

The force sensor described above may comprise a pressure sensor or a sensor for recording a squeezing force. This sensor may optionally be adjustable, both in terms of
5 time and with regard to the force applied to it (threshold value). In addition to the pressure/squeezing forces being measured, they can also be displayed (optionally simultaneously).

A combination of this nature can be used, for example, in a writing instrument. In
10 addition to the squeezing pressure, i.e. the force with which the writing instrument is held by the person writing, it is important to measure the pressure with which the writing instrument is pressed onto the paper or other substrate. A combination of the squeezing force and the pressure force has been found to give an accurate indication of whether or not the writer's behavior is as desired. Measurements have shown that the
15 writing force is between 50 and 150 grams and is on average 70 grams. This pressure is slightly higher in the case of young people. By reducing the writing force, it is possible to obtain maximum relaxation in the neck-shoulder region. Moreover, it has been found that reducing the writing force more or less automatically causes the squeezing force to be reduced. The squeezing force can in principle be reduced to virtually zero, i.e. the
20 writing instrument is scarcely held gripped by the fingers during writing. It has been found that holding the pen in a less cramped way and pressing the pen or other writing instrument less hard onto the writing surface causes more blood to circulate through the arm/shoulder/neck and moreover results in better coordination of finger control, i.e. writing. Also, reducing the cramped posture has a relaxing effect. Moreover, under
25 certain circumstances it is possible to switch off the pressure force signal and to control/train only on the basis of squeezing force. In another variant, it is possible to signal a continuous low squeezing force using pressure pulses and thereby to draw conclusions as to the behavior of the writer. It is also possible for a pen to be of more or less intelligent design, i.e. for diagnosis, optionally in combination with an
30 improvement schedule, to be made even during its first use.

As a result of these variables being stored and then compared, a period later, for example a few days, a week or longer later, with the squeezing/pressure force which is

then current, it is possible to ascertain the progress of the writer. Threshold values for the various sensors can be adjusted on the basis of this progress. In addition to the variant in which threshold values can be set at the writing instrument (if appropriate using software), it is also possible to provide for a variant in which a number of
5 different writing instruments are present, each having a different (fixed) threshold value. These different threshold values may encompass both the squeezing force and the pressure or writing force.

In the case of a sensor which comprises two partial sensors, such as the pressure
10 sensor/sensor for recording a squeezing force described above, it is also possible to emit two different signals in the event of a defined threshold value being exceeded. These signals may comprise light, sound or vibration signals. If a threshold value of this type is exceeded repeatedly or for a prolonged period of time, it is possible to emit recurring signals. According to a particular variant of the present invention, this
15 number of recurring signals is limited. For example, a value of approximately 50 may be mentioned. This makes it possible to prevent operation of a writing instrument or other instrument ending, for example as a result of batteries running out, if, for example, the instrument unintentionally enters a clamping position or other signal-emitting position.

20
As has already been indicated, the writing instrument can also be used to operate any keyboard-like structure, such as a keyboard, screen or the like (such as a calculator or electronic diary). In such a case, the tip of the writing instrument should be covered with an auxiliary structure. By using a specially designed cap, the user can select either
25 to separate the writing instrument with writing tip as exposed part from the cap or to remove the writing instrument including the auxiliary piece from the cap.

The invention relates not only to the measurement of the pressure and squeezing force in a writing instrument, but rather numerous other applications in which problems may
30 arise as a result of acquired deviations are also conceivable. Examples which may be mentioned, without constituting any form of limitation, include toothbrushes and other "tools" on which a squeezing force is exerted.

Musical instruments and in particular bows. Sporting equipment, such as tennis rackets. Chairs, backrests and/or arm rests thereof, beds, footwear and (medical) tools, such as a (dental) drill. Forces are also exerted on car steering wheels and handles of all kinds of objects. As a result of the device according to the invention being integrated in gloves,
5 socks or other items of clothing, it is possible to accurately measure the behavior of the user and to provide advice on the basis of these measurements. In this context, it is important above all to record the forces at the point at which they engage with the surroundings.

10 A further important application is (pen) mice and/or joysticks which are known to cause RSI.

The threshold at which the first signal is emitted can be selected as a function of the particular application, and the time for which a threshold value has to be exceeded can
15 also be set as a function of the particular application. This signal can also be modified for other purposes.

One example of the above is a car steering wheel. If a person steers using one hand or no hands for too long, an unsafe situation may arise, which is detected as an additional
20 effect by the present device, so that a signal, optionally linked to further measures being taken, can be emitted.

In the case of the sporting equipment described above, consideration may be given in particular to tennis and golf. In these sports, undesirable situations may arise if an
25 excessively high force is exerted on the equipment in question for a prolonged period of time. The present invention can be used to determine and correct a trend over the course of time.

Another possible application is beds, in which there is a risk of bedsores. Emitting a
30 signal in good time makes it clear that the patient needs to adopt a different position. The device can also be used for babies, in order to check whether sufficient movement is present.

The invention will be explained below with reference to a number of exemplary embodiments. In the drawing:

Fig. 1 diagrammatically depicts the use of the invention in a mouse;

- 5 Fig 2 shows a writing instrument according to the invention in a first position; and
Fig. 3 shows the writing instrument shown in Fig. 2 in a second position.

In Fig. 1, a mouse is denoted by 1. Apart from the usual buttons, the mouse is also provided with a sensor 2. This sensor may also be arranged beneath the mouse as well
10 as at the position indicated. Moreover, a transmitter denoted by 3 is also present.

The PC operated by this mouse 1 is denoted overall by 5. However, it is provided with an additional processing unit 6, which is diagrammatically indicated and comprises a receiver for receiving the signal from transmitter 3.

15

This device operates as follows. When a user is working using the mouse and is exerting a high squeezing force on it, which is detected by sensor 2, a warning signal will be given on the screen after this threshold value has been exceeded for a certain time. This signal can be repeated regularly in the event of an excessively high gripping
20 force continuing to be applied.

Moreover, this signal is stored in the PC 5 and can be called up. This means that after a certain time, such as a few weeks, the user can see how he has modified his behavior with respect to the mouse. If the results are unfavorable, he needs to take measures to
25 prevent the threshold value at which sensor 2 reacts from being exceeded.

Moreover, during the treatment over the course of time it is possible to reduce the threshold value at which a signal is emitted. This makes it possible to gradually shift from an unhealthy situation into a healthy situation. It has been found that in this way it
30 is possible to eliminate RSI symptoms quickly and efficiently and permanent control is achieved after the correction has ended.

Fig. 2 diagrammatically depicts a writing instrument, which is denoted overall by 11. It

comprises a standard sleeve 12 and a cap 13. 22 denotes the part in which the sensor for recording a squeezing force is arranged, for measuring the squeezing force exerted by the hand. Dashed lines indicate an insert part 23, which comprises a reservoir and a writing tip 14. According to an advantageous embodiment of the invention, this unit 23
5 can be exchanged, so that sleeve 12 and sensor part 22 can be used for both a ballpoint/roller pen, a fountain pen, a felt-tip pen, a pencil, etc. It is easy to introduce a different part 23. Signal lights (LEDs) which indicate that a threshold value has been exceeded, which are not shown, are incorporated in sleeve 12. As an alternative to lights, it is also possible to use a display, counter or the like.

10

Fig. 3 shows the same writing instrument 11 with an auxiliary cap 15 fitted over the writing tip 14.

15

Auxiliary cap 15 can easily be clipped on and may if appropriate be designed in different colors.

20

The design of this writing instrument is such that as a result of the cap 13 being actuated in a defined way, either writing tip 14 is released or auxiliary cap 15 is placed onto the front of the writing tip 14. In the position shown in Fig. 3, keyboard-like structures, such as pads, can be operated.

25

All this is important since the writing instrument 12 is provided, in a manner which is not shown in more detail, with both a sensor for measuring the squeezing force exerted by the fingers on the stem of a writing instrument 12 and with a pressure sensor, which records the force exerted on the free end of the pen when writing or when it is in contact with an operating panel. Moreover, part 12 incorporates signaling means which emit a signal as soon as a defined threshold value for either the pressure force or the squeezing force is exceeded. In this case too, recurring or alternating signals are emitted in the event of the undesired state continuing, and the threshold values can be
30 adjusted downward. In this way, a distinction is drawn between brief peak forces and prolonged, undesirable tensioning of muscles.

The device described above can also be used for percussive instruments, such as tennis

rackets and golf clubs. In such equipment, there is a high peak load which, however, only lasts for a short time. The introduction of a delay means that a short excessive force of this nature will not be recorded.

- 5 Although the invention has been described above on the basis of preferred embodiments, it will be understood that its range of applications is particularly broad. A specific design is associated with each application, and the precise embodiment of this design will be obvious after the above text has been read and lies within the scope of the appended claims.

Claims

1. Device for detecting a pressure force exerted by a human muscle in order to correct use of said muscle, which device comprises a force sensor and which device is provided with a memory, in which the signals originating from said force sensor are stored for at least a few days, as well as a readout/comparison device for reading out said stored signals after at least a week and/or comparing them with signals input more recently, characterized in that said force sensor is designed to emit a warning signal in the event of a threshold value being exceeded, said warning signals being stored in said memory.
2. Device as claimed in claim 1, in which said force sensor is designed in such a manner that in the event of continuous application of a force which exceeds the threshold value, warning signals are emitted regularly.
3. Device as claimed in one of the preceding claims, provided with means for processing a series of signals emitted successively.
4. Device as claimed in one of the preceding claims, in which the force sensor is incorporated in an implement and said memory and said readout/comparison device are arranged separately therefrom.
5. Device as claimed in one of the preceding claims, in which said force sensor is a pressure sensor and/or a sensor which records a squeezing force.
6. Device as claimed in claim 5, arranged in a writing instrument.
7. Device as claimed in claim 6, comprising sensors for recording the gripping force and writing pressure.
8. Device as claimed in claim 6 or 7, in which said writing instrument is provided with operating means for a PC.

9. Device as claimed in one of the preceding claims, arranged in footwear.
 10. Device according to one of the preceding claims, arranged in a toy, game or item of sporting equipment.
- 5
11. Device as claimed in one of the preceding claims, comprising a loadability measurement, wherein the force detected by the force sensor over the course of time is recorded.
- 10
12. Device as claimed in one of the preceding claims, in which said force sensor is designed to emit a warning signal only after the threshold value has been exceeded for a defined time.

1/1

Fig 1

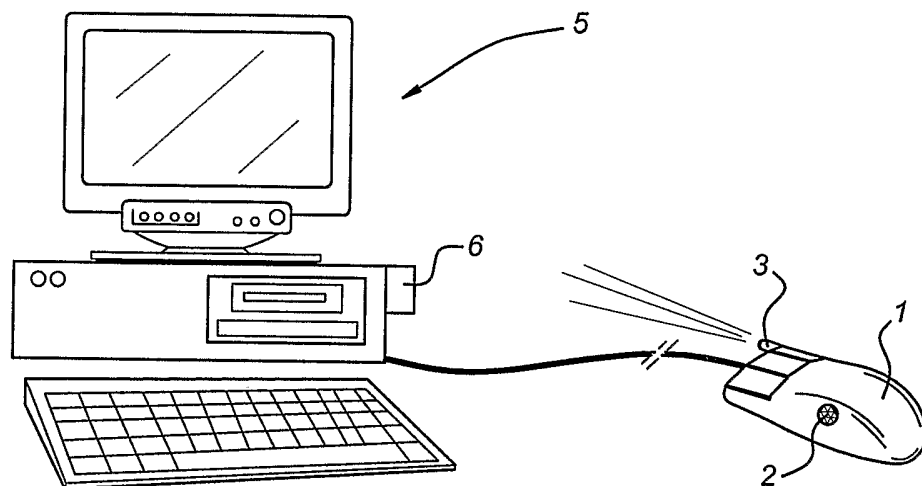

Fig 2

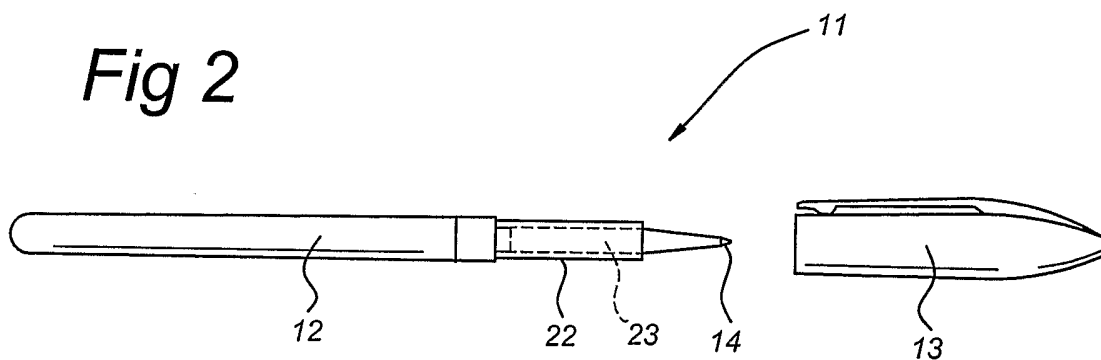
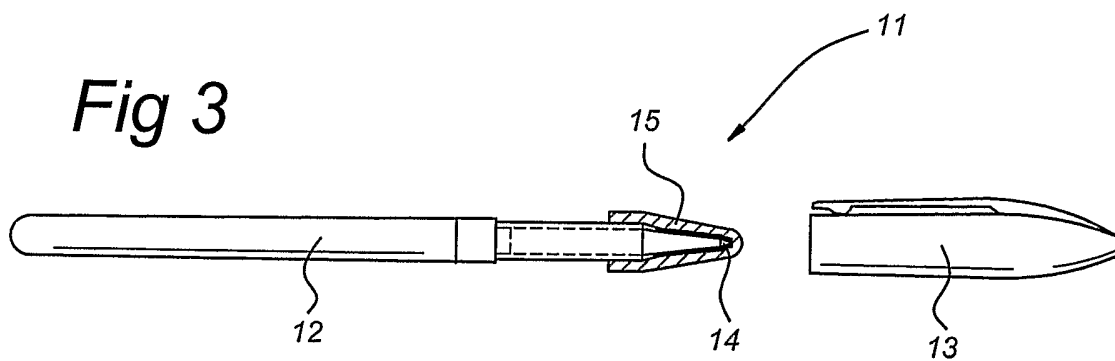

Fig 3



INTERNATIONAL SEARCH REPORT

International Application No

PCT/NL 03/00697

A. CLASSIFICATION OF SUBJECT MATTER
IPC 7 A61B5/22

According to International Patent Classification (IPC) or to both national classification and IPC

B. FIELDS SEARCHED

Minimum documentation searched (classification system followed by classification symbols)
IPC 7 A61B

Documentation searched other than minimum documentation to the extent that such documents are included in the fields searched

Electronic data base consulted during the international search (name of data base and, where practical, search terms used)

EPO-Internal

C. DOCUMENTS CONSIDERED TO BE RELEVANT

Category *	Citation of document, with indication, where appropriate, of the relevant passages	Relevant to claim No.
Y	US 5 429 140 A (BURDEA ET AL.) 4 July 1995 (1995-07-04) cited in the application the whole document -----	1, 4, 11
Y	US 5 579 238 A (KRUGMAN) 26 November 1996 (1996-11-26) the whole document -----	1, 4, 11
Y	US 5 904 639 A (SMYSER ET AL.) 18 May 1999 (1999-05-18) abstract; figures 1-24 -----	1
Y	US 5 681 993 A (HEITMAN) 28 October 1997 (1997-10-28) abstract; figure 6 column 5, line 44 - column 6, line 2 ----- -/--	1

Further documents are listed in the continuation of box C.

Patent family members are listed in annex.

* Special categories of cited documents:

- *A* document defining the general state of the art which is not considered to be of particular relevance
- *E* earlier document but published on or after the international filing date
- *L* document which may throw doubts on priority claim(s) or which is cited to establish the publication date of another citation or other special reason (as specified)
- *O* document referring to an oral disclosure, use, exhibition or other means
- *P* document published prior to the international filing date but later than the priority date claimed

- *T* later document published after the international filing date or priority date and not in conflict with the application but cited to understand the principle or theory underlying the invention
- *X* document of particular relevance; the claimed invention cannot be considered novel or cannot be considered to involve an inventive step when the document is taken alone
- *Y* document of particular relevance; the claimed invention cannot be considered to involve an inventive step when the document is combined with one or more other such documents, such combination being obvious to a person skilled in the art.
- *&* document member of the same patent family

Date of the actual completion of the international search

2 February 2004

Date of mailing of the international search report

11/02/2004

Name and mailing address of the ISA

European Patent Office, P.B. 5818 Patentlaan 2
NL - 2280 HV Rijswijk
Tel. (+31-70) 340-2040, Tx. 31 651 epo nl,
Fax: (+31-70) 340-3016

Authorized officer

Hunt, B

INTERNATIONAL SEARCH REPORT

Internatic pplication No

PCT/NL 03/00697

C.(Continuation) DOCUMENTS CONSIDERED TO BE RELEVANT		
Category °	Citation of document, with indication, where appropriate, of the relevant passages	Relevant to claim No.
A	US 5 447 167 A (FLEISCHAKER) 5 September 1995 (1995-09-05) the whole document -----	5-8
A	NL 1 006 708 C (VITELEC B.V.) 2 February 1999 (1999-02-02) abstract; figures 1-3 -----	9,10
A	WO 01/072223 A (SAN DIEGO STATE UNIVERSITY FOUNDATION) 4 October 2001 (2001-10-04) page 18, line 23 - page 20, line 15; figures 1-12 -----	1
A	EP 0 592 735 A (SHAH ET AL.) 20 April 1994 (1994-04-20) the whole document -----	1

INTERNATIONAL SEARCH REPORT

II Information on patent family members

International application No

PCT/NL 03/00697

Patent document cited in search report		Publication date	Patent family member(s)	Publication date
US 5429140	A	04-07-1995	NONE	
US 5579238	A	26-11-1996	CA 2247972 A1 WO 9733145 A1 AU 5185696 A EP 0885379 A1 JP 2001518209 T	12-09-1997 12-09-1997 22-09-1997 23-12-1998 09-10-2001
US 5904639	A	18-05-1999	NONE	
US 5681993	A	28-10-1997	NONE	
US 5447167	A	05-09-1995	NONE	
NL 1006708	C	02-02-1999	NL 1006708 C2	02-02-1999
WO 0172223	A	04-10-2001	US 6352516 B1 AU 5102801 A CA 2404224 A1 EP 1276415 A2 WO 0172223 A2 US 2001049482 A1	05-03-2002 08-10-2001 04-10-2001 22-01-2003 04-10-2001 06-12-2001
EP 0592735	A	20-04-1994	EP 0592735 A1 DE 69220796 D1 US 5184628 A	20-04-1994 14-08-1997 09-02-1993