



(12) **United States Design Patent**
Cassard

(10) **Patent No.:** **US D958,005 S**
(45) **Date of Patent:** **** Jul. 19, 2022**

- (54) **TRUCK CABIN**
- (71) Applicant: **ARQUUS**, Versailles (FR)
- (72) Inventor: **Laurent Cassard**, Versailles (FR)
- (73) Assignee: **ARQUUS**, Versailles (FR)
- (**) Term: **15 Years**
- (21) Appl. No.: **35/510,931**
- (22) Filed: **Oct. 6, 2020**
- (80) **Hague Agreement Data**
 Int. Filing Date: **Oct. 6, 2020**
 Int. Reg. No.: **DM/211562**
 Int. Reg. Date: **Oct. 6, 2020**
 Int. Reg. Pub. Date: **Dec. 11, 2020**

4,126,350	A *	11/1978	Briers	B62D 33/06
					296/190.08
D286,031	S *	10/1986	Breitschwerdt	D12/96
4,813,736	A *	3/1989	Schubert	B62D 65/04
					180/89.18
4,964,671	A *	10/1990	Millar	B60P 3/0252
					296/64
5,282,661	A *	2/1994	Arnberger	B62D 31/006
					296/190.04
D367,443	S *	2/1996	Sacco	D12/96
D389,437	S *	1/1998	Olausson	D12/96
D403,620	S *	1/1999	Abalos	D12/96
D408,331	S *	4/1999	Sacco	D12/96
D411,142	S *	6/1999	Sacco	D12/96
D411,816	S *	7/1999	Reynard	D12/96
D412,301	S *	7/1999	Dirks	D12/96
D412,463	S *	8/1999	Sacco	D12/96
D412,683	S *	8/1999	Sacco	D12/96
D416,829	S *	11/1999	Sacco	D12/96
D557,648	S *	12/2007	Rice, Jr.	D12/195
D570,739	S *	6/2008	Emoto	D12/96
D570,740	S *	6/2008	Emoto	D12/96
D570,741	S *	6/2008	Emoto	D12/96
D571,259	S *	6/2008	Emoto	D12/96

(Continued)

- (30) **Foreign Application Priority Data**
 Jun. 8, 2020 (EM) 007990221
- (51) **LOC (13) Cl.** **12-08**
- (52) **U.S. Cl.**
 USPC **D12/96; D12/84; D12/195**
- (58) **Field of Classification Search**
 USPC **D12/82, 84, 86, 92, 96, 100, 195**
 CPC **B62D 23/00; B62D 25/00; B62D 31/02;**
B62D 31/04; B62D 53/062; B62D 65/00;
B60G 2202/152; B60G 2300/14; B60P
3/007; B21D 53/88
 See application file for complete search history.

Primary Examiner — Darlington Ly
(74) *Attorney, Agent, or Firm* — Thompson Coburn LLP;
Steven M. Ritchey

(57) **CLAIM**
The ornamental design for a truck cabin, as shown and described.

DESCRIPTION

- 1. Truck cabin
- 1.1** is a front and left side perspective view of a truck cabin embodying my new design;
- 1.2** is a rear and right side perspective view thereof;
- 1.3** is a front elevation view thereof;
- 1.4** is a rear elevation view thereof;
- 1.5** is a top plan view thereof;
- 1.6** is a left side elevation view thereof; and
- 1.7** is a right side elevation view thereof.

1 Claim, 7 Drawing Sheets



(56)

References Cited

U.S. PATENT DOCUMENTS

7,419,214 B2 * 9/2008 Plant B64D 11/0643
244/118.6
D628,133 S * 11/2010 Counts D12/195
8,284,327 B2 * 10/2012 Counts B60N 2/01
348/739
D818,921 S * 5/2018 Pelletier D12/195
10,059,383 B2 * 8/2018 Pelletier A61G 3/061
10,071,320 B2 * 9/2018 Levine A63H 17/002
D830,712 S * 10/2018 Goode D6/338
10,124,895 B2 * 11/2018 Simeon B64D 11/0015
D842,785 S * 3/2019 Balicki D12/195
D849,625 S * 5/2019 Yamamoto D12/195
D878,245 S * 3/2020 Lamanna D12/84
D883,857 S * 5/2020 Lamanna D12/84

* cited by examiner

1.1

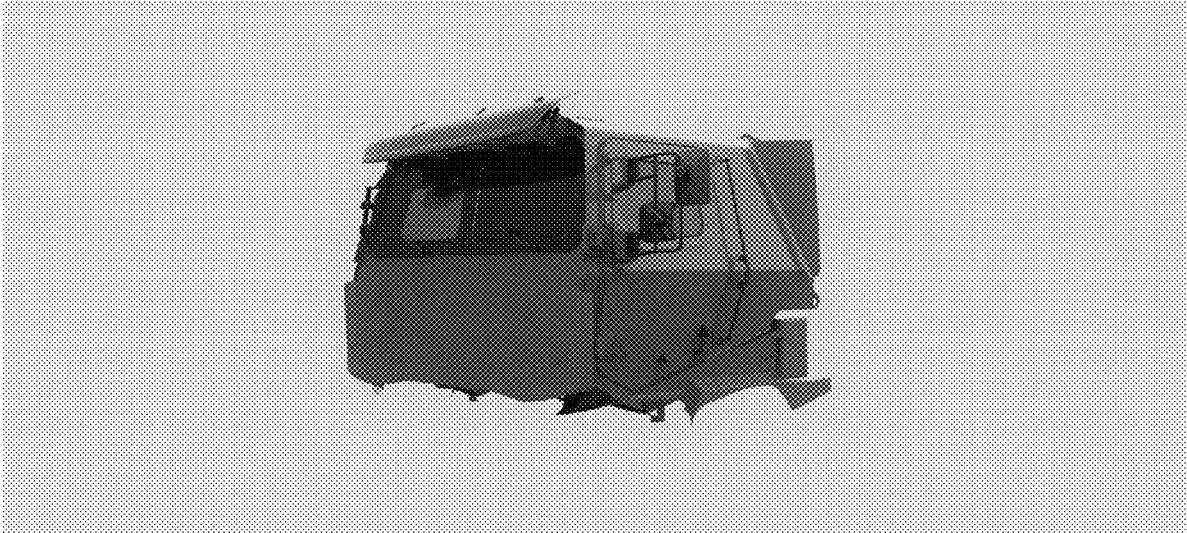

1.2

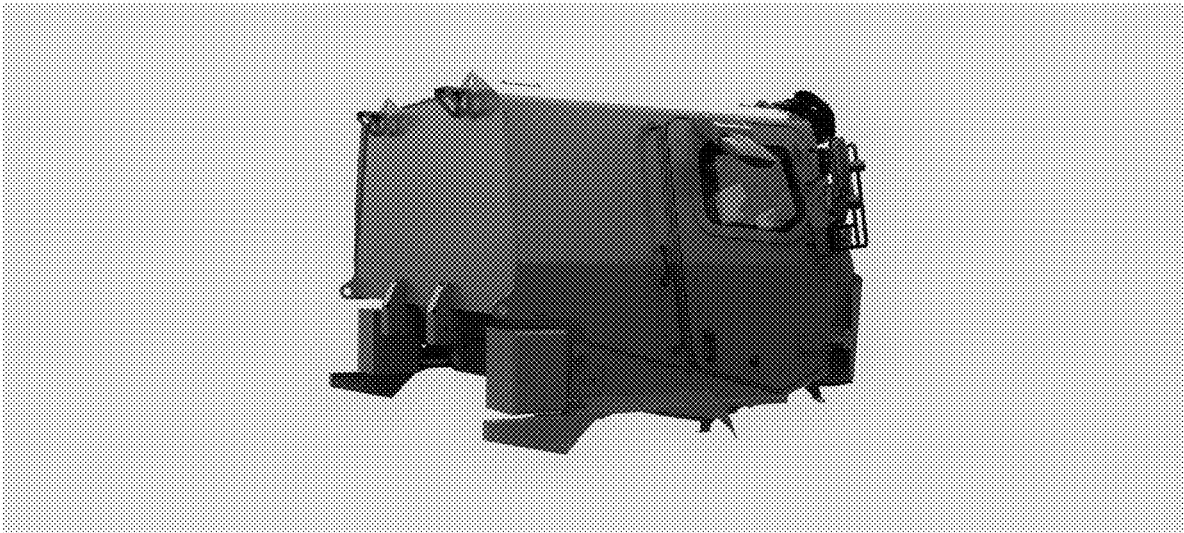

1.3

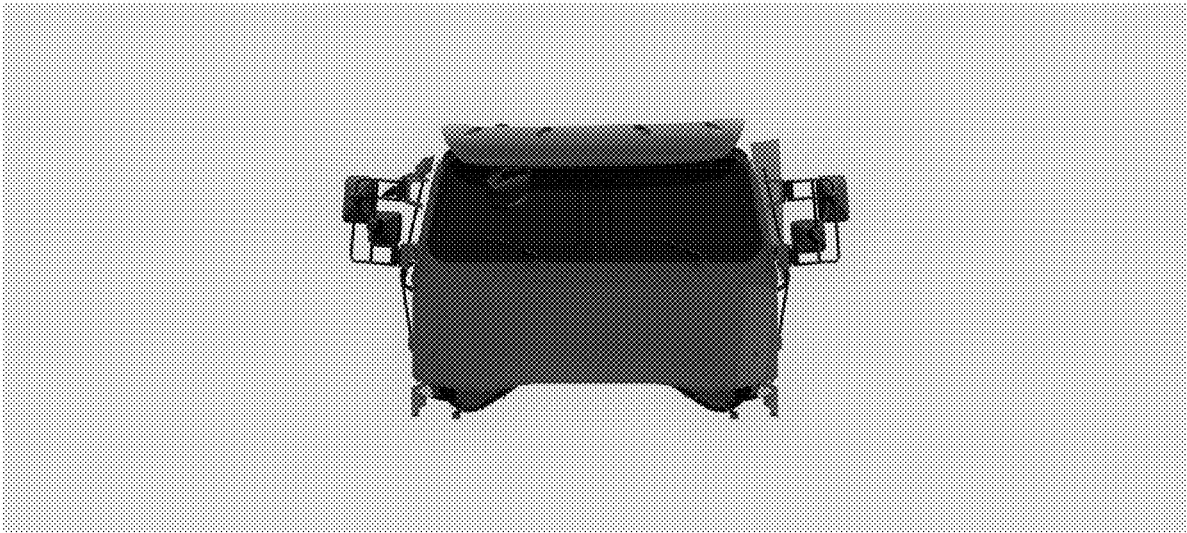

1.4

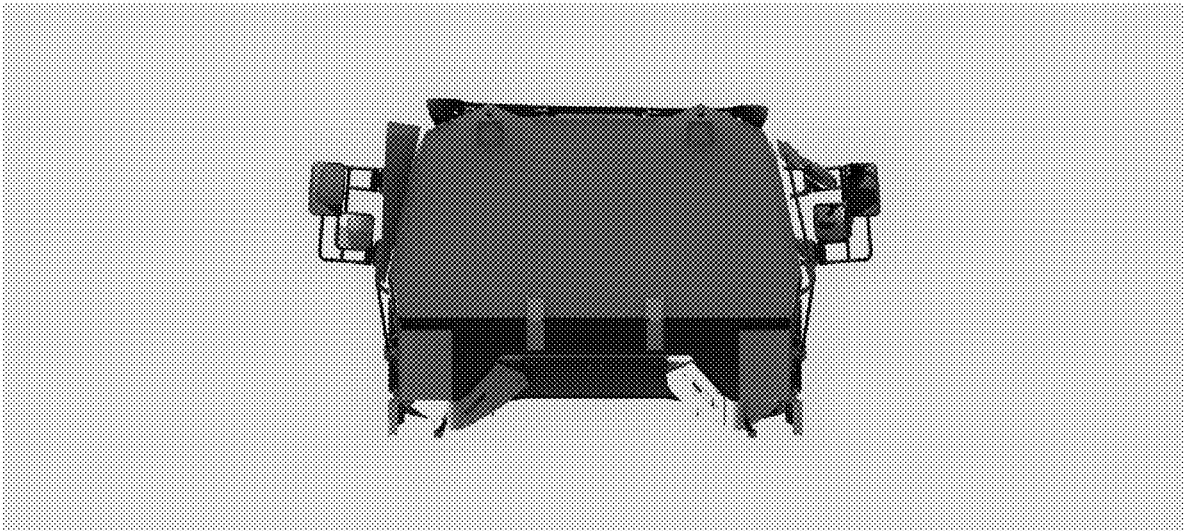

1.5

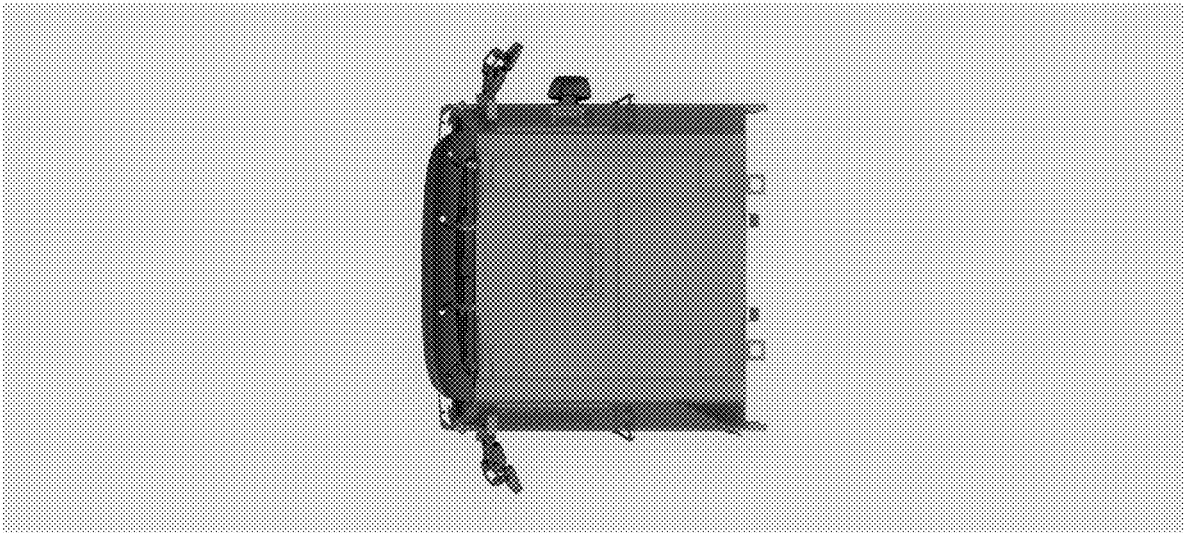

1.6

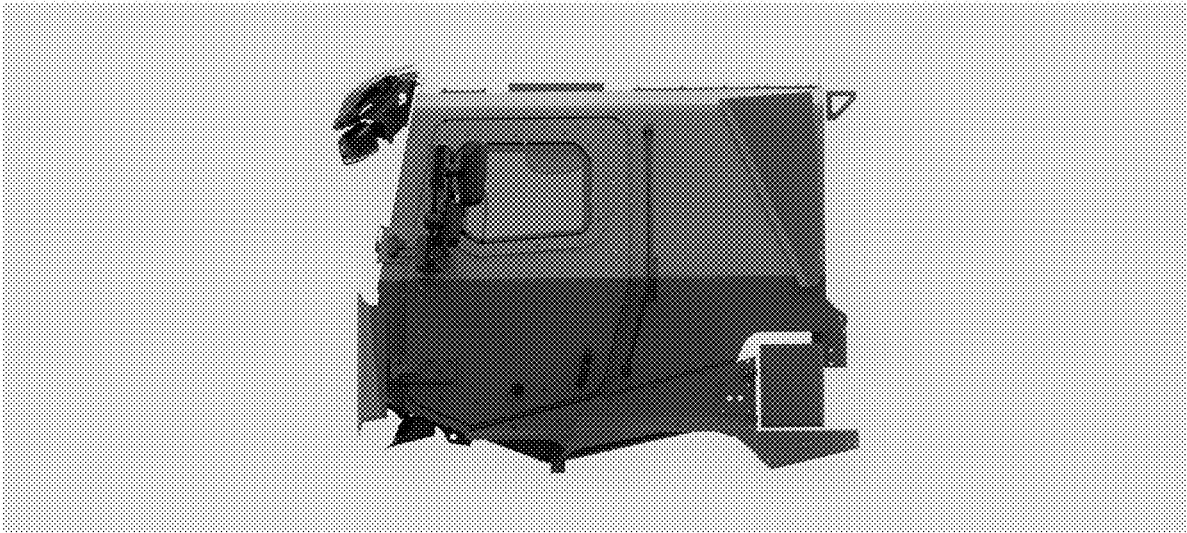

1.7

