



US00D433365S

# United States Patent [19]

[11] Patent Number: **Des. 433,365**

**Beigel**

[45] Date of Patent: **\*\* Nov. 7, 2000**

[54] **SIDE SKIRT OF A TRUCK VEHICLE**

[75] Inventor: **David J. Beigel**, Kettering, Ohio

[73] Assignee: **Navistar International Transportation Corp**, Chicago, Ill.

[\*\*] Term: **14 Years**

D. 420,622 2/2000 Hellhake et al. .

D. 423,990 5/2000 Meryman et al. .... D12/96

D. 424,495 5/2000 Damon et al. .... D12/196

*Primary Examiner*—Melody N Brown  
*Attorney, Agent, or Firm*—Jeffrey P. Calfa; Dennis Kelly Sullivan

[21] Appl. No.: **29/114,057**

[22] Filed: **Nov. 17, 1999**

### [57] CLAIM

The ornamental design for a side skirt of a truck vehicle, as shown and described.

[51] **LOC (7) Cl.** ..... **12-16**

[52] **U.S. Cl.** ..... **D12/196**

[58] **Field of Search** ..... D12/196, 93, 97,  
 D12/96; 296/196, 197, 181; 180/89.1, 89.11,  
 89.12, 89.14, 89.16

### DESCRIPTION

FIG. 1 is a perspective view of a left side embodiment of a side skirt of a truck vehicle showing my new design; FIG. 2 is a front view of the invention shown in FIG. 1; FIG. 3 is a rear side view of the invention shown in FIG. 1; FIG. 4 is a bottom view of the invention shown in FIG. 1; FIG. 5 is a top view of the invention shown in FIG. 1; FIG. 6 is a side view of the invention shown in FIG. 1; and, FIG. 7 is a side view of a right side embodiment of a side skirt of a truck vehicle showing my new design.

[56] **References Cited**

**U.S. PATENT DOCUMENTS**

D. 320,582 10/1991 Fingerle ..... D12/196

D. 391,908 3/1998 Allendorph et al. .

D. 399,791 10/1998 Hellhake et al. .... D12/96

**1 Claim, 3 Drawing Sheets**

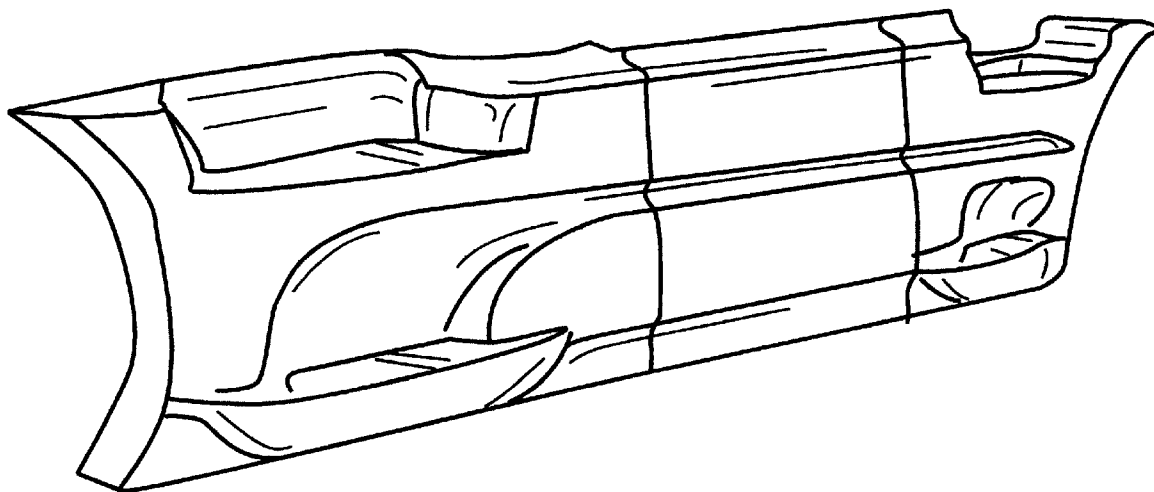

FIG. 2

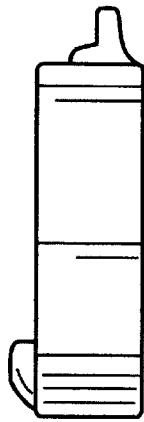

FIG. 3

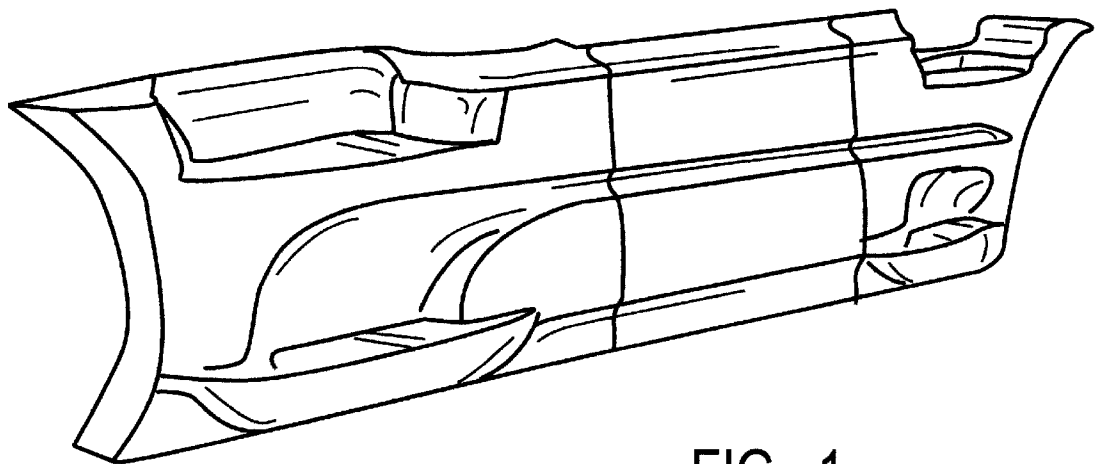
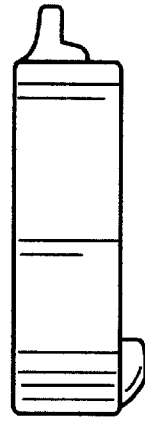

FIG. 1

FIG. 4



FIG. 5



FIG. 6

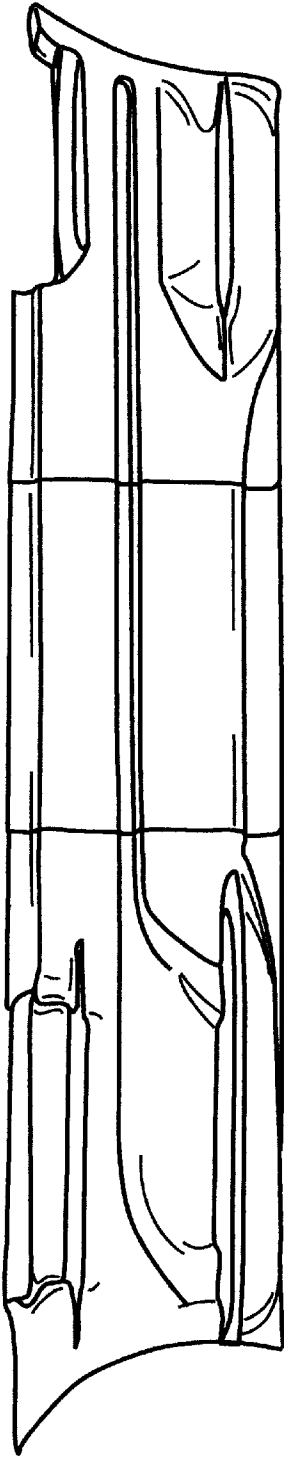

FIG. 7

