

W. ORR.  
FIREPROOF CONSTRUCTION.

No. 582,308.

Patented May 11, 1897.

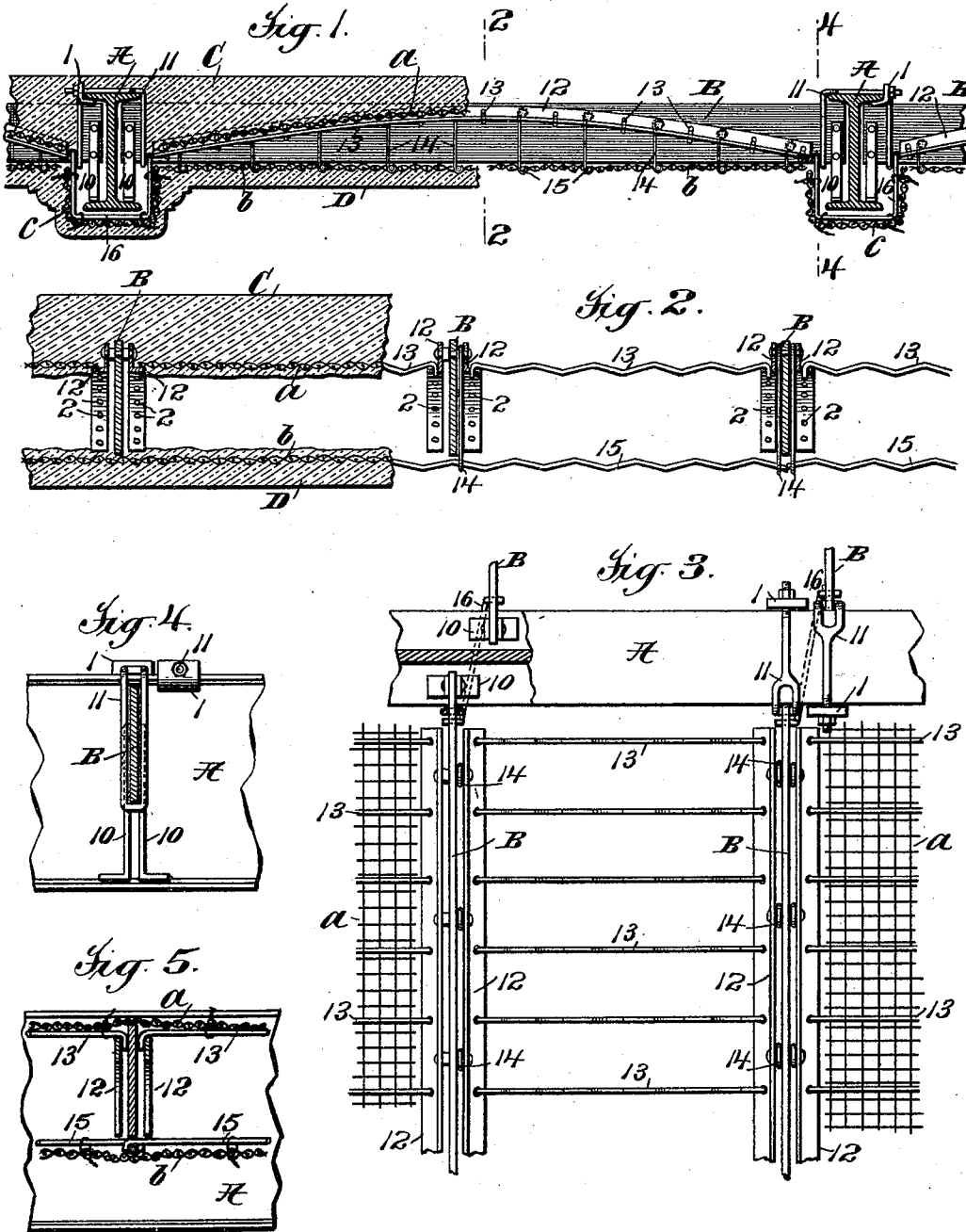

Attest:  
*A. D. Bourke*  
*G. M. Dorsch*

Inventor  
 William Orr  
 By *Philip W. Mansfield*  
 Attys

(No Model.)

2 Sheets—Sheet 2.

W. ORR.  
FIREPROOF CONSTRUCTION.

No. 582,308.

Patented May 11, 1897.

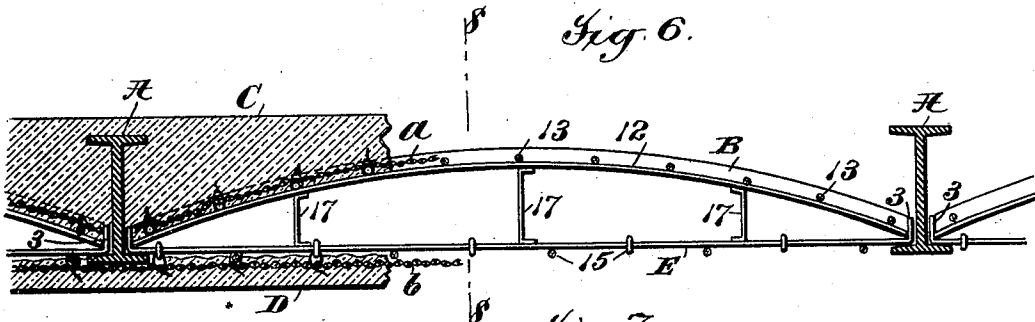

Fig. 6.

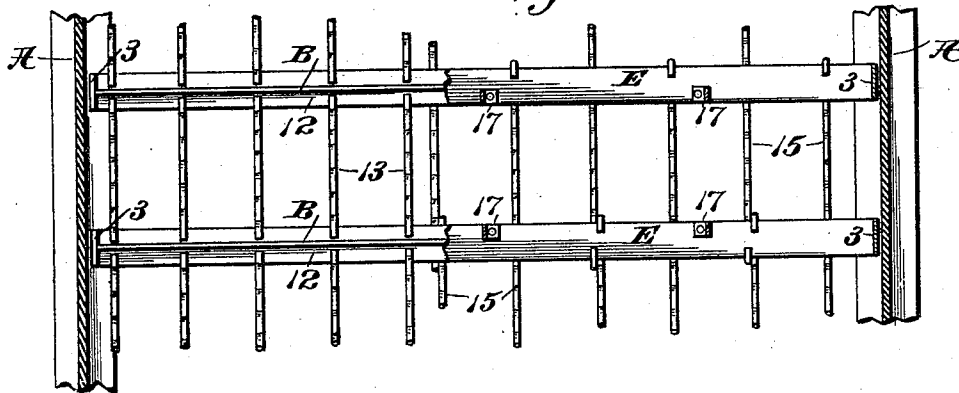

Fig. 7.

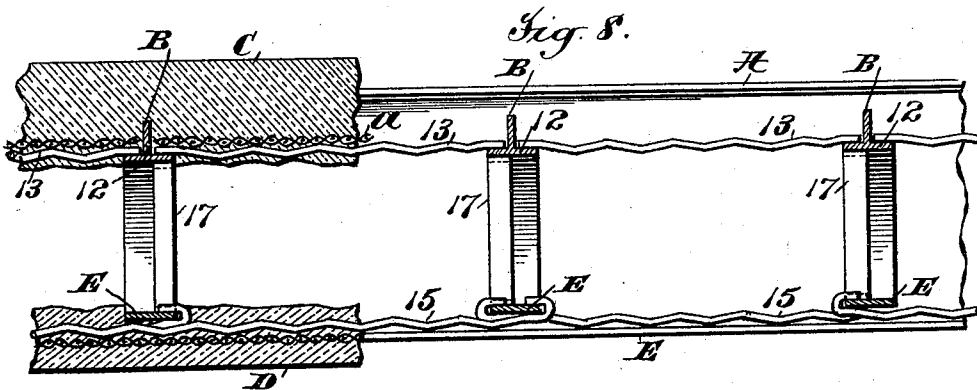

Fig. 8.

Attest:  
A. V. Bourke  
J. M. Doran

Inventor  
William Orr  
By Philip Munson Phelps  
Attys

# UNITED STATES PATENT OFFICE.

WILLIAM ORR, OF TRENTON, NEW JERSEY, ASSIGNOR TO THE NEW JERSEY WIRE CLOTH COMPANY, OF SAME PLACE.

## FIREPROOF CONSTRUCTION.

SPECIFICATION forming part of Letters Patent No. 582,308, dated May 11, 1897.

Application filed January 4, 1896. Serial No. 574,312. (No model.)

*To all whom it may concern:*

Be it known that I, WILLIAM ORR, a citizen of the United States, residing at Trenton, county of Mercer, and State of New Jersey, have invented certain new and useful Improvements in Fireproof Constructions, fully described and represented in the following specification and the accompanying drawings, forming a part of the same.

The object of the present invention is to provide an improved fireproof construction adapted especially for use as a combined floor and ceiling construction, the especial object of the invention being to provide an improved construction employing metal-plate joists and metallic lathing to support a floor of concrete or other similar plastic material.

I aim particularly at the formation of a construction in which it is necessary only that the floor-joists be stiff enough on their depth to carry the required load, the setting of the concrete or other plastic material in the meshes of the lathing securing an anchorage which prevents thrust against the joists, making it unnecessary to provide the heavy flanges usually employed to give the joists side stiffness.

While, however, the invention is especially adapted for use in fireproof floor and ceiling constructions and the invention consists in part of features therein, the invention includes also certain features of construction and combinations of parts which may be used in other concrete and similar constructions.

As a full understanding of the invention can best be given by an illustration and detailed description of constructions embodying the same, such a description will now be given in connection with the accompanying drawings, forming a part of this specification and showing constructions of the preferred forms, and the features forming the invention will then be specifically pointed out in the claims.

In the drawings, Figure 1 is a section of a complete floor and ceiling construction, the section being taken transversely to the floor-beams and the floor and ceiling concrete being partially broken away to show the construction. Fig. 2 is a cross-section on the line 2 of Fig. 1, showing the concrete in part of the construction. Fig. 3 is a plan view, partly

in section, of a portion of the construction complete without the concrete. Fig. 4 is a detail section on the line 4 of Fig. 1. Fig. 5 is a detail section similar to Fig. 2, showing a slight modification. Figs. 6 to 8 show a modified construction, which may be found quite efficient, in which the arch may be supported with less weight of metal than in the construction shown in Figs. 1 to 5. Fig. 6 is a view similar to Fig. 1. Fig. 7 is a horizontal section taken through the I-beams above the arch and with the joists partly broken away, the plastic material and lathing being omitted. Fig. 8 is a vertical cross-section on the line 8 of Fig. 6.

Referring to said drawings, A are the floor-beams, which are shown as of the common I form, and B the floor-joists, extending between the beams and formed of comparatively thin metal plates. These joists in the construction shown in Figs. 1 to 5 are formed of quite wide plates of metal provided at opposite ends with feet 10, which may be formed on but are preferably riveted or otherwise secured to the plates and rest upon the lower flanges of the beams A, so as to support the joists, and the joists are preferably held in position and partially supported by means of metal hangers 11, which depend from the tops of the beams and extend beneath the lower edges of the joists, these hangers in the construction shown being secured to the beams by clips 1, hooked over the top edges of the beams and provided with openings through which the hangers 11 are passed and adjustably secured under the proper tension by means of nuts, as shown, or in any other suitable manner. While the joists are preferably supported both by the lower flanges of the beams A and by the tops of the beams through hangers, it will be understood that either of these means may be found sufficient in some cases and used without the other. The construction is illustrated as applied in connection with the common I floor-beams, but it will be understood that other forms of beams may be used and the joists supported thereon or in any other suitable manner, and that the joists may be supported by the walls of a building instead of by floor or other beams.

The joists B form the supports for the

floor, which is formed of a body of concrete or other similar plastic material held by metallic lathing carried by the joists, and in the preferred construction shown, and which in itself forms a part of the invention, the floor-concrete is so supported as to form an arched floor and a ceiling combined therewith which is supported by the joists at some distance below the floor, so as to form arched air-spaces between the floor and ceiling. In this construction the lathing is supported as follows: Upon opposite sides of the joists B and curved so as to form an arch extending between the beams A are supports 12, which may be formed integral with the joists B, but when wide joists are used, as in the construction now being described, preferably consist of angle-plates bolted to the joists, these angle-plates being shown as offset for a purpose presently to be described. The flanges of these angle-plates are provided with perforations 2 at intervals throughout their entire length, and through these perforations are passed the hooked ends of rods 13, which support the lathing *a*, these rods 13 being either woven into the lathing, as shown in the drawings, or having the lathing secured thereto in any suitable manner. Upon the lathing *a*, which may be of any suitable form, either woven wire, as shown, or perforated sheet metal, is applied the body of floor-concrete C, which fills the space above the supports 12 to the tops of the joists and beams, and upon which a board floor may be placed, if desired.

The construction thus far described is complete in case a separate ceiling is not to be made, but one of the objects of the invention is to provide a floor and ceiling construction with air-spaces between the two, and the ceiling construction will now be described.

In the construction shown in Figs. 1 to 4 the angle-plates forming the supports 12 are offset, as previously described, and from the rivets by which the offset plates 12 are secured to the joists B, and inside the plates, are hung supports 14, which are hooked over the rivets and about supporting-rods 15, which extend along beneath the lower edges of the joists B, these rods being woven into the ceiling-lathing *b*, as shown in these figures, although they may be separate from the lathing and the latter secured thereto by lacing or in any other suitable manner. The flanges of the beams A may be covered in any suitable manner, but, as shown, supporting-rods 16 are hooked into perforations in the joists B on opposite sides of the beams A and pass around the lower flanges of the latter, and upon these rods 16 is supported metallic lathing *c*. A body of plastic material D is applied to and supported by the rods 15 16 and lathing *b c*, thus completing the ceiling construction and extending the same below and about the beam-flanges.

It will now be understood that the angle-plates forming the supports 12 are offset from

the joists B especially for the purpose of receiving the hooked hangers 14 inside the plates, and that if the ceiling be otherwise supported the supports 12 may be formed on or secured directly against the joists B.

As shown in Figs. 1 to 4, the rods 13 and 15 are corrugated transversely at short intervals throughout their length, so as to secure the tensile strength of the rod in addition to the bending resistance, and the rods may be formed therewith or secured thereto in any suitable manner, the rods and lathing then being embedded in the concrete or similar plastic material. These corrugated rods may be formed very simply and cheaply by corrugating-rolls or other similar convenient devices in the formation of the rods or lathing containing the rods.

In Fig. 5 is shown a slightly-modified construction in which the arched supports 12 are flat pieces of metal secured to and offset from the joists B and the rods 13 are hooked over the edges of the plates between them and the joists B instead of through perforations in flanges on the plates. In this construction also the rods 15, which support the ceiling-lathing *b*, are passed through openings provided in the lower edges of the joists B and supported thereby instead of by separate hangers 14, as in the construction shown in Figs. 1 to 4. In this construction also the rods 13 15, instead of being woven into the lathing *a b*, as in the construction shown in Figs. 1 to 4, are separate therefrom and the lathing secured thereto by lacing or otherwise. The rods 13 15, moreover, are shown as straight instead of the preferred corrugated form previously described, as it is obvious that straight rods may be used in constructions embodying the general features of the invention.

In the constructions thus far described the thrust of the arch formed by the supports 12 and the lathing and concrete carried thereby is borne by the wide plates forming the joists B and by the beams A.

In Figs. 6 to 8 I have shown a construction in which the thrust of the arch may be supported with less weight of metal than in the constructions shown in Figs. 1 to 5 and by which also the thrust of the arch may be supported practically without thrust on the beams A or other supports of the joists, which latter feature is especially important where the joists are supported by the walls of a building. In the construction shown in these figures the webs of the joists B are quite narrow and the joists B and supports 12 are preferably formed integral and consist of arched T-plates, as shown, these beams being inverted, so that the cross-bar is at the bottom of the web and forms the flanges constituting the supports 12. The rods 13, lathing *a*, and concrete C are supported in this construction by these supports 12, as in the construction previously described, except that the rods 13 and lathing thereon are shown as simply laid upon the tops of the flanges, which construction will

be found efficient with stiff lathing or rods, especially where the joists are placed quite close together, as shown. The flanges forming the supports, however, may be perforated  
5 and the hooked rods used as in the other constructions, if preferred, and the hooked-rod construction is important in some cases and in connection with the arched supports forms a specific feature of the invention.

10 The thrust of the arch is supported by the tensile member E, which is shown as formed of a metal bar or plate resting upon the lower flanges of the I-beams, although it will be understood that it may be supported in any other  
15 suitable manner, either on the I-beams or with beams of other forms or on the walls. At its opposite ends each of the tensile members E is provided with a vertical flange 3, which receives the ends of the compression members  
20 B, so that the compression of the arch is supported by these flanges, and thus resisted by the tensile strength of the bars E. The compression and tensile members B E may be secured together by riveting or otherwise instead  
25 of using the flanged ends, but the construction shown will be found simple and efficient. Between the compression and tensile members B E are preferably placed at intervals supports 17, these intermediate supports  
30 being riveted, clamped, or otherwise attached to both members. It will be understood, however, that these intermediate supports will not be required in all constructions. The bars E support the rods 15 and lathing *b* of the ceiling, the rods 15 being secured to the  
35 bars in any suitable manner. As shown, the rods extend along beneath the bars and the ends of the rods are hooked about them, so as to be supported thereby.

40 It will be obvious that the joists shown in Figs. 6 to 8, having the webs and flanges forming the supports 12 formed integral and consisting of T-plates with a narrow web, may be used without the tensile members E in constructions in which no ceiling is required or  
45 with the ceiling supported in any other suitable manner, but it is obvious that in such constructions the thrust of the arch will be supported by the I-beams, and such a construction is not so well adapted for heavy  
50 floors, and especially where the joists are supported by the walls of the building.

It will be understood that many other modifications may be made in the constructions  
55 shown without departing from the invention, and I am not to be limited to the exact form or arrangement of parts illustrated.

What is claimed is—

60 1. The combination of joists formed of plates supported on their edges, whereby the pressure of material supported by the plates is exerted edgewise of the plates, metallic lathing between and supported by said joists and curved longitudinally of the joists to  
65 form horizontal arches, and a filling of concrete or similar plastic material applied to said lathing, substantially as described.

2. The combination of joists formed of plates supported on their edges, whereby the pressure of material supported by the plates  
70 is exerted edgewise of the plates, arched supports on the opposite side faces of said joists, metallic lathing carried by said supports and curved longitudinally of the joists to form horizontal arches, and a filling of concrete or  
75 similar plastic material applied to said lathing, substantially as described.

3. The combination of joists formed of plates supported on their edges, whereby the pressure of material supported by said plates  
80 is exerted edgewise of the plates, metallic lathing between and supported by joists and curved longitudinally of the joists to form horizontal arches, a filling of concrete or similar plastic material applied to said lathing,  
85 and a ceiling of metallic lathing and plastic material below said arches, substantially as described.

4. The combination of joists, arched supports on said joists, rods extending trans-  
90 versely to said joists and carried by said supports, metallic lathing on said rods curved longitudinally of the joists to form arches, and a filling of concrete or similar plastic material applied to said lathing, substantially as  
95 described.

5. The combination of joists, arched supports on said joists, rods extending trans-  
100 versely to said joists and carried by said supports, metallic lathing on said rods curved longitudinally of the joists to form arches, a filling of concrete or similar plastic material applied to said lathing, rods supported by said joists and extending transversely to the  
105 joists below the arches, and a ceiling of metallic lathing and plastic material supported by said rods, substantially as described.

6. The combination with beams, of metal joists B supported by said beams and formed of metal plates supported on their edges,  
110 whereby the pressure of material supported by said plates is exerted edgewise of the plates, arched supports 12 on said joists, and arched metallic lathing and plastic material carried by said supports, substantially as described.  
115

7. The combination with beams, of metal joists B supported by said beams and formed of metal plates supported on their edges,  
120 whereby the pressure of material supported by said plates is exerted edgewise of the plates, arched supports 12 on said joists, arched metallic lathing and plastic material carried by said supports, and a ceiling of metallic lathing and plastic material, substantially as described.  
125

8. The combination with beams, of metal joists B supported by said beams, arched supports 12 on said joists, rods 13 carried by said supports, and metallic lathing and plastic material carried by said rods 13, substantially  
130 as described.

9. The combination with beams, of metal joists B supported by said beams, arched supports 12 on said joists, rods 13 carried by said

supports, ceiling-rods 15, and metallic lathing and plastic material carried by said rods 13, 15, substantially as described.

10 5 joists B supported by said beams, arched supports 12 on said joists, rods 13 carried by said supports, rods 15 supported by said joists at their bottom edges, and metallic lathing and plastic material carried by said rods 13, 15, 10 substantially as described.

11. The combination with the flanged beams A, of the metal joists B extending from beam to beam, flanged supports 10 secured to said joists and resting on the flanges of said beams, 15 and hangers 11 for the joists extending over the tops of the beams, substantially as described.

12. A joist formed of a plate B provided with arched flanges extending transversely to 20 the plate, and perforated at suitable intervals for the attachment of metallic lathing or lathing-supporting rods, substantially as described.

13. A joist formed of a plate B provided 25 with arched perforated flanges extending transversely to the plate, in combination with rods hooked to said flanges and metallic lathing supported by said rods, substantially as described.

14. A joist formed of a plate B provided 30 with arched supports and having perforations at its lower edge in combination with floor-rods on said supports, ceiling-rods extending through the perforations, and lathing supported by said rods, substantially as described. 35

15. A joist formed of a plate B provided with supports offset to leave a space between the supports and the face of the plate, substantially as described.

16. A joist formed of a plate B provided 40 with supports offset to leave a space between the supports and the face of the plate and having perforations at its lower edge, substantially as described.

17. A joist formed of a metal plate B provided 45 with arched supports on the face of the plate, said plate projecting below the supports and having perforations arranged in substantially a straight line at its lower edge, substantially as described. 50

In testimony whereof I have hereunto set my hand in the presence of two subscribing witnesses.

WM. ORR.

Witnesses:

R. L. VANDEGRIFT,  
E. W. ARNOLD.