

(19) World Intellectual Property
Organization
International Bureau



(43) International Publication Date
18 November 2004 (18.11.2004)

PCT

(10) International Publication Number
WO 2004/100313 A1

- (51) International Patent Classification⁷: **H01Q 9/04**, 5/00, 1/24
- (21) International Application Number:
PCT/EP2004/050599
- (22) International Filing Date: 23 April 2004 (23.04.2004)
- (25) Filing Language: English
- (26) Publication Language: English
- (30) Priority Data:
0310829.7 12 May 2003 (12.05.2003) GB
10/462,693 17 June 2003 (17.06.2003) US
- (71) Applicant (for all designated States except US): **NOKIA CORPORATION** [FI/FI]; Keilalahdentie, FIN-02150 Espoo (FI).
- (72) Inventors; and
- (75) Inventors/Applicants (for US only): **WANG, Hanyang** [GB/GB]; 71 Barrington Close, Witney, Witney Oxfordshire OX8 0PW (GB). **ZHANG, Su Qing** [GB/GB]; 26 Wentworth Road, Oxford, Oxford Oxfordshire OX2 7TH (GB).
- (74) Agents: **KHAN, Saiful** et al.; Nokia IPR Department, Nokia House, Summit Avenue, Farnborough Hampshire GU14 0NG (GB).
- (81) Designated States (unless otherwise indicated, for every kind of national protection available): AE, AG, AL, AM, AT, AU, AZ, BA, BB, BG, BR, BW, BY, BZ, CA, CH, CN, CO, CR, CU, CZ, DE, DK, DM, DZ, EC, EE, EG, ES, FI, GB, GD, GE, GH, GM, HR, HU, ID, IL, IN, IS, JP, KE, KG, KP, KR, KZ, LC, LK, LR, LS, LT, LU, LV, MA, MD, MG, MK, MN, MW, MX, MZ, NA, NI, NO, NZ, OM, PG, PH, PL, PT, RO, RU, SC, SD, SE, SG, SK, SL, SY, TJ, TM, TN, TR, TT, TZ, UA, UG, US, UZ, VC, VN, YU, ZA, ZM, ZW.
- (84) Designated States (unless otherwise indicated, for every kind of regional protection available): ARIPO (BW, GH, GM, KE, LS, MW, MZ, SD, SL, SZ, TZ, UG, ZM, ZW), Eurasian (AM, AZ, BY, KG, KZ, MD, RU, TJ, TM), European (AT, BE, BG, CH, CY, CZ, DE, DK, EE, ES, FI, FR, GB, GR, HU, IE, IT, LU, MC, NL, PL, PT, RO, SE, SI, SK, TR), OAPI (BF, BJ, CF, CG, CI, CM, GA, GN, GQ, GW, ML, MR, NE, SN, TD, TG).
- Published:**
— with international search report
- For two-letter codes and other abbreviations, refer to the "Guidance Notes on Codes and Abbreviations" appearing at the beginning of each regular issue of the PCT Gazette.

(54) Title: OPEN-ENDED SLOTTED PIFA ANTENNA AND TUNING METHOD

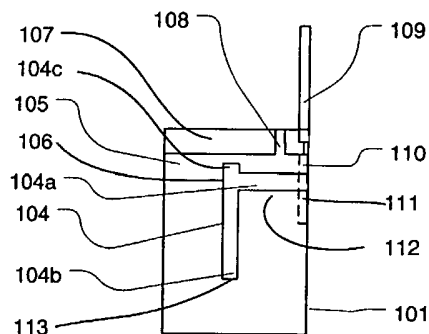

(57) Abstract: A method of independently modifying the $1/4$ and/or the $3/4$ wavelength resonant frequency in an open-ended slotted PIFA antenna, an open-ended slotted PIFA antenna comprising an antenna feed (109, 110) and an antenna ground wherein the antenna ground is associated with the antenna short-circuit end, and an open-ended slot having an open-end associated with the antenna open-circuit end (108), and wherein the antenna ground and the slot (104) are mutually arranged to provide operational variations in the current density between the open and short circuit ends of the antenna and around the perimeter of the slot, and an operational mean current path length between the open and short circuit ends of the antenna and around the perimeter of the open-ended slot, the mean current path length determining the $1/4$ and $3/4$ wavelength resonant frequencies for the open-ended slotted PIFA antenna, the method comprising determining operational variations in current density around the perimeter of a

pre-modified open-ended slotted PIFA antenna and modifying the mean current path length around the perimeter of the pre-modified open-ended slot in regions of comparatively high current density.

WO 2004/100313 A1

OPEN-ENDED SLOTTED PIFA ANTENNA AND TUNING METHOD

5 Field of the Invention

The present invention relates to open-ended slotted PIFA antennas having a $\frac{1}{4}$ wavelength resonance mode at a first frequency and a $\frac{3}{4}$ wavelength resonance mode at a second frequency and a method of adjusting the frequency ratio between the $\frac{1}{4}$ and $\frac{3}{4}$ wavelength resonant frequencies while
10 maintaining independent control of the $\frac{1}{4}$ wavelength and $\frac{3}{4}$ wavelength resonant frequencies. The method can be used in the design/manufacture of open-ended slotted PIFA antennas with $\frac{1}{4}$ and $\frac{3}{4}$ wavelength resonance modes which can have resonance frequencies which vary from the normal
15 1:3 ratio. The present invention also relates to multi-band antennas.

Background to the Invention

In recent years there has been a move towards harmonising mobile phone systems throughout the world. For instance, many countries have GSM900
20 systems enabling users from one country to use their mobile phones in another country. However, this harmonisation has not yet been completed. For instance, spectrum availability has led to the introduction of DCS1800 which is similar to GSM900 but operates in a band in the region of 1800MHz
25 rather than 900MHz as in the case of GSM. Additionally, national spectrum management authorities do not necessarily decide to allocate the same bands to the public land mobile network service. For instance, in the United States of America a DCS1800-like system (PCS1900) is implemented in a band in the region of 1900MHz. Further incompatibilities arise during
30 transitional periods when a new system is being introduced and an old one phased out.

Accordingly, there is a need to provide a mobile phone antenna which can operate at various frequencies.

Summary of the Invention

5

The invention provides methods and antennas according to the claims, and also as described with reference to specific embodiments.

Brief Description of the Drawings

10

Embodiments of the present invention will now be described, by way of example, with reference to the accompanying drawings in which :

Figure 1 is a prior art perspective view of what is known in the art as a slotted PIFA antenna with an indirect feed (not shown);

Figure 2 is a plan view of Figure 1, illustrating the indirect feed;

Figure 3 is a schematic representation of the current flow around the prior art antenna of Figure 2 at the $\frac{1}{4}$ wavelength resonant frequency;

Figure 4 is a return loss v frequency plot illustrating the $\frac{1}{4}$ wavelength resonant frequency of the prior art antenna of Figure 2;

Figure 5 is a schematic representation of the current flow around the prior art antenna of Figure 2 at the $\frac{3}{4}$ wavelength resonant frequency;

Figure 6 is a return loss v frequency plot illustrating the $\frac{3}{4}$ wavelength resonant frequency of the prior art antenna of Figure 2;

Figure 7 is a drawing of a first embodiment of an antenna according to the present invention;

Figure 8 is a schematic representation of the current flow around the antenna of Figure 7 at the $\frac{1}{4}$ wavelength resonant frequency;

Figure 9 is a return loss v frequency plot illustrating the $\frac{1}{4}$ wavelength resonant frequency of the antenna of Figure 7;

30

Figure 10 is a schematic representation of the current flow around the antenna of Figure 7 at the $\frac{3}{4}$ wavelength resonant frequency;

Figure 11 is a return loss v frequency plot illustrating the $\frac{3}{4}$ wavelength resonant frequency of the antenna of Figure 7;

5 Figure 12 is a drawing of a second embodiment of an antenna according to the present invention;

Figure 13 is a schematic representation of the current flow around the antenna of Figure 12 at the $\frac{1}{4}$ wavelength resonant frequency;

10 Figure 14 is a return loss v frequency plot illustrating the $\frac{1}{4}$ wavelength resonant frequency of the antenna of Figure 12;

Figure 15 is a schematic representation of the current flow around the antenna of Figure 12 at the $\frac{3}{4}$ wavelength resonant frequency;

Figure 16 is a return loss v frequency plot illustrating the $\frac{3}{4}$ wavelength resonant frequency of the antenna of Figure 12;

15 Figure 17 is a drawing of a third embodiment of an antenna according to the present invention;

Figure 17a is a drawing of the third embodiment of the antenna with a direct feed arrangement;

20 Figure 18 is a schematic representation of the current flow around the antenna of Figure 17 at the $\frac{1}{4}$ wavelength resonant frequency;

Figure 19 is a return loss v frequency plot illustrating the $\frac{1}{4}$ wavelength resonant frequency of the antenna of Figure 17;

Figure 20 is a schematic representation of current flow around the antenna of Figure 17 at the $\frac{3}{4}$ wavelength resonant frequency;

25 Figure 21 is a plot illustrating the $\frac{3}{4}$ wavelength resonant frequency of the antenna of Figure 17;

Figures 22 to 26 illustrate alternative slot forms of the slotted PIFA antenna according to the present invention;

30 Figure 27 is a perspective view of a multi-band antenna comprising two slotted PIFA antennas according to the present invention;

Figure 28 is a plan view of the antenna illustrated in Figure 27;

Figure 29 is a return loss v frequency plot illustrating the $\frac{1}{4}$ wavelength and the $\frac{3}{4}$ wavelength resonant frequencies of the antenna illustrated in Figure 27;

5 Figure 30 is a plan view of the antenna illustrated in Figure 27 comprising a single feed structure.

Detailed Description of the Preferred Embodiment

10 A prior art drawing of what is known in the art as a quarter wavelength resonant slotted PIFA antenna 1 is illustrated in Figure 1 disposed on a substrate 2 mounted (mounting not shown) to the main Printed Circuit Board (PCB) 3 of a radio communication device. The antenna/substrate 1/2 are generally rectangular in shape and lie above and parallel to a major face 3a of the larger rectangular main printed circuit board 3. Such an antenna is
15 configured to resonate at a $\frac{1}{4}$ wavelength resonant frequency (e.g. 980MHz) and a $\frac{3}{4}$ wavelength resonant frequency (e.g. 2.8GHz) by virtue of its geometry (overall size/shape, slot size/shape/position). It will be appreciated that the frequencies quoted against specific antenna geometries throughout the text are provided for guidance purposes and do not necessarily reflect
20 actual frequencies for specific geometries.

The antenna 1, which is disposed on the away facing (with respect to the underlying PCB 3) surface 5 of the substrate 2, is formed from copper (a
25 conductive material). Furthermore, the antenna 1 comprises an inverted L-shaped slot 4 which is defined by the absence of copper from a L-shaped region (4a, 4b) of the conductive layer 5. The slot 4 comprises a first section 4a which extends perpendicularly from approximately a third of the way down the right hand side of the substrate 2 and extends to approximately midway across the surface 5 to a first distal end 6. The slot 4 has a second section
30 4b extending at a right angle from the first distal end 6 towards the lowermost edge of the surface 5 to a second distal end 13 (Figures 1-2).

The copper conductor is also absent from a margin 7 along the upper edge of the surface 5, save for a branch 8 situated towards the right hand side of the surface 5 and extending to the upper edge of the substrate 2 (Figures 1-2). The branch 8 is electrically grounded so as to define a fixed electrical short circuit (minimum E field position).

The antenna's feed 9, 10 is provided on the underside (with respect to surface 5) of the substrate 2, this underside facing the major face 3a of the PCB 3. The feed comprises a coaxial cable 9 and a conductive strip 10 (indicated with dashed lines in Figure 2) aligned with the right hand edge of the substrate 2. The feed 9, 10 does not form a conductive path to the surface 5 and will be recognised by those skilled in the art as an indirect feed arrangement. The conductive strip 10 starts at the edge of the aforementioned margin 7 and extends until it coincides with the electrically open circuit of the slotted PIFA antenna 1, which in Figure 2, is approximately midway down the right hand edge of the substrate 2. This position is also known as the maximum E field position 11.

The surface 5 of the antenna 1 acts as a $\frac{1}{4}$ wavelength resonant element at a first frequency (Figure 3, 4). This antenna 1 is also resonant at a second frequency which will be approximately three times the first frequency (Figure 5, 6) i.e. also acts as a $\frac{3}{4}$ wavelength resonant element. It should be noted that what is known in the art as a $\frac{1}{4}$ wavelength resonant PIFA antenna would be resonant at frequencies which are odd integer multiples of a quarter wavelength, e.g. $\frac{1}{4}$, $\frac{3}{4}$ etc. The antenna 1 may have resonant frequencies which are not exact integer multiples of a quarter wavelength due to antenna coupling effects, which can occur when the distal end 12 of the conductive layer 5 is in close proximity to the branch 8. However, such coupling effects apply to all the resonant frequencies at the same time (to varying degrees).

The current density around the prior art antenna 1 will now be described by way of example at the $\frac{1}{4}$ and $\frac{3}{4}$ wavelength resonant frequencies. For clarity

and simplicity, the current densities will be treated separately but it will be appreciated by those skilled in the art that the current densities, as shown in Figures 3 and 5 of the antenna 1 can occur simultaneously when the antenna 1 is excited by both the $\frac{1}{4}$ and $\frac{3}{4}$ wavelength resonant frequencies.

5 The antenna 1 of Figure 2 is illustrated with the electrical current flow around the structure at the $\frac{1}{4}$ wavelength resonant frequency in Figure 3. The electrical current flow is substantially located around the perimeter of the slot 4, flowing in a clockwise direction from the maximum E field position 11 of the antenna 1 to the short circuit end of the antenna, which coincides with the branch 8 (minimum E field position). The maximum electrical current density occurs at the short circuit end of the antenna 1 at the branch 8 (minimum E field position), which is electrically grounded. The minimum electrical current density occurs at the open circuit end of the antenna 1 which coincides with the maximum E field position 11 which is approximately midway down the right hand side of the substrate 2. There is only one occurrence each of the maximum and minimum electrical current densities. The mean path length taken by the current around the slot 4 determines the $\frac{1}{4}$ wavelength of the antenna. The resultant $\frac{1}{4}$ wavelength resonant frequency in this case is 980MHz and is illustrated in Figure 4.

25 The antenna 1 of Figure 2 is illustrated with the electrical current flow around the structure at the $\frac{3}{4}$ wavelength resonant frequency in Figure 5. Again, the electrical current flow is substantially located around the perimeter of the slot 4, flowing in a clockwise direction from the maximum E field position 11 of the antenna 1 to the short circuit end of the antenna 1, which coincides with the branch 8 (minimum E field position). However, in this case, there are two occurrences each of the maximum and minimum electrical current density. A first maxima 15 of the electrical current density occurs at the short circuit end of the antenna 1 which coincides with the branch 8, which is electrically grounded. A second maxima 16 occurs at a position which is electrically $\frac{1}{2}$ wavelength away in a counter-clockwise direction around the slot 4 from the

first maxima 15, coinciding with a position which is towards the lowermost edge of the section 4b. The first minima 17 of the electrical current density occurs at a position which is electrically a $\frac{1}{4}$ wavelength away in a counter-clockwise direction around the slot 4 from the first maxima 15 and coincides
5 with a position which is approximately mid-way down the left hand edge of the section 4b. The second minima 18 of the electrical current density occurs at the open circuit end of the antenna which coincides with a position approximately mid-way down the right hand side of the substrate 2 and coincides with the maximum E field position 11. The mean path length taken
10 by the current around the slot 4 determines the $\frac{3}{4}$ wavelength of the antenna.

The resultant $\frac{3}{4}$ wavelength resonant frequency is shown at 2800MHz in Figure 6. As mentioned earlier, and as in this case, the $\frac{1}{4}$ and $\frac{3}{4}$ wavelength resonant frequencies of the prior art slotted PIFA antenna 1 (980MHz and
15 2800MHz) do not have a numerical ratio of exactly 1:3. As indicated already this is due to coupling effects between the distal end 12 of the surface 5 being in close proximity to the branch 8

An antenna according to the present invention will now be described by
20 making modifications to the antenna 1 of Figure 2 by altering the current path length around the slot 4 to realise three embodiments of the present invention (Figures 7, 12 and 17). In each case, the mean current path length, with respect to the prior art of Figure 2, has been changed by altering the perimeter/shape of the slot 4. The figure references 1-13 of Figures 1 and 2
25 have corresponding reference numbers 101, 201, 301 to 113, 213, 313 within Figures 7, 12 and 17 respectively.

The antenna 101 shown in Figure 7 is the same as the antenna 1 of Figures 1 and 2 except that the inverted-L shape slot 4 of antenna 1 has a third section 104c to form a substantially r-shaped slot. The third section 104c
30 extends at a right angle towards the uppermost edge of the substrate 102 from the distal end 106 of the first section 104a, orientated about the same vertical axis as the second section 104b.

The electrical current flow around the structure of the antenna 101 of Figure 7 is illustrated in Figure 8 at the $\frac{1}{4}$ wavelength resonant frequency. It is similar to Figure 3, with corresponding features appropriately labelled. The mean path length taken by the current around the slot 104 determines the $\frac{1}{4}$ wavelength of the antenna and this arrangement provides a $\frac{1}{4}$ wavelength resonant frequency at 950MHz (Figure 9). Comparing Figures 3 and 8, it can be seen that the antenna 1 has been modified by the addition of the third section 104c to the slot 4. This modification has resulted in a change in the mean current path length in an area where the current density is large (c.f. the position of the maximum current density in Figure 3 and 8 is largely unchanged given the small change in the perimeter of the slot 4). Changing the perimeter of the slot 4 where the current density is large and thereby changing the mean current path length where the current density is large changes the $\frac{1}{4}$ wavelength resonant frequency of the antenna 1. By increasing the current path length we have changed the resonant frequency from 980MHz to 950MHz. Correspondingly, it will also be appreciated that a reduction in the slot perimeter where the current density is large and therefore a reduction in the mean current path length where the current density is large would result in the $\frac{1}{4}$ wavelength resonant frequency increasing.

The antenna 101 of Figure 7 is illustrated with the electrical current flow around the structure at the $\frac{3}{4}$ wavelength resonant frequency in Figure 10. It is similar to Figure 5, with corresponding features appropriately labelled. The mean path length taken by the current around the slot 104 determines the $\frac{3}{4}$ wavelength of the antenna. The resultant $\frac{3}{4}$ wavelength resonant frequency is 2780MHz and is shown in Figure 11. Comparing Figures 5 and 10, it can be seen that the antenna 1 has been modified by the addition of the third section 104c to the slot 4. This modification has resulted in a change in the mean current path length in an area where the current density is small (c.f. the position of the minimum current density in Figure 6 and 11 is largely unchanged). Comparing Figures 6 and 11, it can be seen that changing the perimeter of the slot 4 where the current density is small and thereby

changing the mean current path length where the current density is small has a modest change on the $\frac{3}{4}$ wavelength resonant frequency of the antenna 101. By increasing the current path length we have changed the resonant frequency from 2800MHz to 2780MHz. Correspondingly, it will also be appreciated that a reduction in the slot perimeter where the current density is small and therefore a reduction in the mean current path length where the current density is small would result in the $\frac{3}{4}$ wavelength resonant frequency increasing.

10 In summary, the addition of the slot 104c to the antenna 1 substantially changes the $\frac{1}{4}$ wavelength resonant frequency of the antenna 101 and has a minimal effect on the $\frac{3}{4}$ wavelength resonant frequency.

A second embodiment is shown in Figure 12 in which the antenna 201 is the same as the antenna 1 of Figures 1 and 2 except that the inverted-L shape slot 4 of antenna 1 has an additional section 204d to form a substantially C-shaped slot. The additional section 204d has been added at a right angle to the distal end 213 of the section 204b and extends in a direction towards the right hand edge of the substrate 202. Figure 13 illustrates with the electrical current flow around the structure at the $\frac{1}{4}$ wavelength resonant frequency. The current flow is similar to Figure 3, with corresponding features appropriately labelled. The mean path length taken by the current around the slot 204 determines the $\frac{1}{4}$ wavelength of the antenna, and is 970 MHz in this case (Figure 14).

25 Comparing Figures 3 and 13, it can be seen that the antenna 1 has been modified by the addition of the section 204d to the slot 4. This modification has resulted in a change in the mean current path length in an area where the current density is low. Comparing Figures 4 and 14 it can be seen that changing the perimeter of the slot 204 where the current density is low and thereby changing the mean current path length where the current density is low will change the $\frac{1}{4}$ wavelength resonant frequency of the antenna 1. By increasing the current path length we have changed the resonant frequency from 980MHz to 970MHz. Correspondingly, it will also be appreciated that a

reduction in the slot perimeter where the current density is low and therefore a reduction in the mean current path length where the current density is low would result in the $\frac{1}{4}$ wavelength resonant frequency increasing.

5 The antenna 201 of Figure 12 is illustrated with the electrical current flow around the structure at the $\frac{3}{4}$ wavelength resonant frequency in Figure 15 It is similar to Figure 5, with corresponding features appropriately labelled. The mean path length taken by the current around the slot 204 determines the $\frac{3}{4}$ wavelength of the antenna, and in this case is 2700MHz (Figure 16).

10 Comparing Figures 5 and 15, it can be seen that the antenna 1 has been modified by the addition of the section 204d to the slot 4. This modification has resulted in a change in the mean current path length in an area where the current density is large. Referring to figures 6 and 16 it can be seen that
15 changing the perimeter of the slot 204 where the current density is large and thereby changing the mean current path length where the current density is large will change the $\frac{3}{4}$ wavelength resonant frequency of the antenna 201. By increasing the current path length we have changed the resonant frequency from 2800MHz to 2700MHz. It will also be appreciated that a
20 reduction in the slot perimeter where the current density is large and therefore a reduction in the mean current path length where the current density is large would result in the $\frac{3}{4}$ wavelength resonant frequency increasing.

25 In summary and with reference to Figures 3 to 16 it will be appreciated that the addition of the slot 204d to the antenna 1 substantially changes the $\frac{3}{4}$ wavelength resonant frequency of the antenna 201 and has a minimal effect on the $\frac{1}{4}$ wavelength resonant frequency.

30 A third embodiment is shown in Figure 17, in which the antenna 301 is the same as the antenna 1 of Figures 1 and 2 except that the inverted-L shape slot 4 of antenna 1 has an additional third section 304c and fourth section 304d to form a substantially t-shaped slot 304. The third section 304c extends at a right angle towards the uppermost edge of the substrate 302

from the distal end 306 of the first section 304a and is oriented about the same vertical axis as the second section 304b. The fourth section 304d has been added at a right angle to the distal end 313 of the section 304b and extends in a direction towards the right hand edge of the substrate 302.

5

The antenna 301 of Figure 17 is illustrated with the electrical current flow around the structure at the $\frac{1}{4}$ wavelength resonant frequency in Figure 18. It is similar to Figure 3, with corresponding features appropriately numbered. The mean path length taken by the current around the slot 304 determines

10

the $\frac{1}{4}$ wavelength of the antenna and in this case is 940MHz (Figure 19). Comparing Figures 3 and 18 it can be seen that the antenna 1 has been modified by the addition of the sections 304c and 304d to the slot 4. Comparing Figures 4 and 19 it can be seen that changing the perimeter of

15

the slot 304 will change the $\frac{1}{4}$ wavelength resonant frequency of the antenna 1. By increasing the current path length we have changed the resonant frequency from 980MHz to 940MHz. Correspondingly, it will also be appreciated that a reduction in the slot perimeter where the current density is large and therefore a reduction in the mean current path length where the

20

current density is large would result in the $\frac{1}{4}$ wavelength resonant frequency increasing. The antenna 301 of Figure 17 is illustrated with the electrical current flow around the structure at the $\frac{3}{4}$ wavelength resonant frequency in Figure 20. It

25

is similar to Figure 5, with corresponding features appropriately numbered. The mean path length taken by the current around the slot 304 determines the $\frac{3}{4}$ wavelength of the antenna and in this case is 2680 MHz (Figure 21). Comparing Figures 5 and 20 it can be seen that the antenna 1 has been

30

modified by the addition of the sections 304c and 304d to the slot 4. Comparing Figures 6 and 21 it can be seen that changing the perimeter of the slot 304 and thereby changing the mean current path length will change the $\frac{3}{4}$ wavelength resonant frequency of the antenna 301. By increasing the current path length we have changed the resonant frequency from 2800MHz

to 2680MHz. Correspondingly, it will also be appreciated that a reduction in the slot perimeter where the current density is large and therefore a reduction in the mean current path length where the current density is large would result in the $\frac{3}{4}$ wavelength resonant frequency increasing.

5

In summary, it will be appreciated that the addition of section 304c to the antenna 1 has a substantial effect on the change in $\frac{1}{4}$ wavelength resonant frequency of the antenna 1, whereas the addition of section 304c to the antenna 1 has a minimal effect on the change in $\frac{3}{4}$ wavelength resonant frequency of the antenna 1. Furthermore, it will also be appreciated that the addition of section 304d to the antenna 1 has a substantial effect on the change in $\frac{3}{4}$ wavelength resonant frequency of the antenna 1, whereas the addition of the section 304d to the antenna 1 has a minimal effect on the change in $\frac{1}{4}$ wavelength resonant frequency of the antenna 1. It will be appreciated that the addition of sections 304c or 304d has the effect of independently controlling the $\frac{1}{4}$ wavelength or $\frac{3}{4}$ wavelength resonant frequency respectively while the other $\frac{3}{4}$ wavelength or $\frac{1}{4}$ wavelength resonant frequency respectively is substantially fixed. It will also be appreciated that the rate of change of $\frac{1}{4}$ and $\frac{3}{4}$ wavelength resonant frequency is determined by the extent to which the geometry (overall size/shape, slot size/shape/position) of the slot 4 is altered and also where the geometry is altered with respect to the $\frac{1}{4}$ and $\frac{3}{4}$ wavelength maximum current densities around the slot 4.

25 The embodiments described in Figures 7, 12 and 17 illustrate the use of an indirect feed structure, 109, 110, 209, 210 and 309, 310 respectively. A direct feed arrangement (Figure 17a) could be used in preference to an indirect feed arrangement. The use of either feed structure does not change the functionality of the described invention.

30

Antenna 351 (Figure 17a) is the same as antenna 301 (Figure 17) except that the indirect feed structure 309, 310 has been replaced by a direct feed structure 359, 360. The features 301-308 and 311-314 of Figure 17 are corresponding numbered 351-358 and 361-364 in Figure 17a. The direct feed

arrangement comprises a conductive branch 359 which is adjacent to and to the right hand side of the grounded branch 358. The conductive branch has similar dimensions to the branch 358 and is electrically connected to the surface 355. In an alternative arrangement (not shown) the position of the
5 grounded branch 358 and the conductive branch 359 may be swapped or their positions relative to one another may be adjusted. A co-axial cable 360 is connected to the conductive strip 359 at one end and the other of the co-axial cable 360 is connected to radio circuitry (not shown).

10 The present invention is not restricted to the slot forms 104, 204 and 304 shown in Figures 7, 12 and 17 respectively. Figures 22 - 26 illustrate alternative slot forms 404-804. Each of the antennas 401-801 illustrated in Figures 22-26 has a short circuited branch (not shown) along the top edge of the surface 405, 505, 605, 705 and 805 respectively and an indirect feed (not
15 shown) similar to that illustrated by 9, 10 in Figure 2 towards the right hand edge of the surface.

Slot 404 is a T- shaped slot comprising slotted sections 404a and 404b. It has an open-ended cross piece 404a extending horizontally across the
20 surface 405 of the substrate 402, (Figure 22). A second slot 404b extends vertically downwards from a position midway along the slot 404a.

Slot 504 is an I-shaped slot comprising slotted sections 504a, 504b and 504c. It has an open-ended cross-piece 504a extending horizontally across the
25 surface 505 of the substrate 502 (Figure 23). A second slot 504b extends vertically downwards from a position midway along the slot 504a. A third slot 504c lies parallel to slot 504a and is connected midway along its length to slot 504b. Slot 504c is shorter in length than slot 504a.

30 Slot 604 is a substantially L-shaped slot comprising slotted sections 604a and 604b. Slot 604 has an open-ended slot 604a extending horizontally across the surface 605 of the substrate 602 to a distal end 606 (Figure 24). A second slot 604b extends downwards at a right angle from the distal end 606

of the slot 604a to a distal end 613. The slot 604b is substantially rectangular except at the distal end 613 where the perimeter is semi-circular.

5 Slot 704 is a substantially y-shaped slot comprising slotted sections 704a and 704b. The open-ended slot 704a extends diagonally from the upper right hand edge of the surface 705 towards the lower left hand edge of the surface 705 (Figure 25). A second slot 704b extends vertically upwards from a position approximately midway along the slot 704a

10 Slot 804 is a substantially T-shaped slot comprising slotted sections 804a and 804b. It has an open-ended cross-piece 804a extending horizontally across the surface 805 of the substrate 802, (Figure 26). A second slot 804b extends downwards from a position midway along the slot 804a and at a right angle thereto. The second slot 804b is terminated at the distal end 813 with a
15 non-uniform width caused by the distal end of the slot 804b being wavy.

Slot 404 (Figure 22) illustrates a means of adjusting the $\frac{1}{4}$ wavelength resonant frequency of the antenna 401 by the addition of section 404aa (highlighted by the cross hatched section) when compared to the antenna 1 of figure 2. Slot 704 (Figure 25) illustrates a means of adjusting the $\frac{1}{4}$
20 wavelength resonant frequency of the antenna 701 by the addition of section 704b (highlighted by the cross hatched section) when compared to a prior art slotted PIFA antenna (not shown).

25 The slots 504aa and 504c of Figure 23 and slots 804aa and 804bb (highlighted by the cross hatched sections) of Figure 26 illustrate alternative means of adjusting the $\frac{1}{4}$ wavelength and $\frac{3}{4}$ wavelength resonant frequencies respectively when compared to the antenna 1 of Figure 2.

30 Slot 604bb (highlighted by the cross hatched section) shown in Figure 24 illustrates a means of adjusting the $\frac{3}{4}$ wavelength resonant frequency when compared to the antenna 1 of Figure 2.

In an alternative arrangement, re-locating the short circuit branch 8 to alternative positions on the surfaces 405, 505, 605, 705 and 805 would result in the slotted forms shown in antennas 401, 501, 601, 701 and 801 having different effects on the $\frac{1}{4}$ and $\frac{3}{4}$ wavelength resonant frequencies when compared to the antenna 1 of Figure 2. For example, if the short circuited branch 8 as shown in Figure 2 were moved to a position mid way down the right hand edge of the surface 705 of Figure 25 (not shown) then the addition of the slot 704b would have a minimal effect on the $\frac{1}{4}$ wavelength resonant frequency but would alter the $\frac{3}{4}$ wavelength resonant frequency.

The present invention provides a means of adjusting the frequency ratio between the $\frac{1}{4}$ and $\frac{3}{4}$ wavelength resonant frequencies while maintaining independent control of the $\frac{1}{4}$ wavelength and $\frac{3}{4}$ wavelength resonant frequencies. In an application where more than two resonant frequencies are required, for example in a multi-band mobile handset, the use of two quarter wavelength resonant slotted PIFA planar elements according to the present invention would give up to four resonant frequencies at the $\frac{1}{4}$ and $\frac{3}{4}$ wavelength resonant frequencies. A further implementation of the present invention illustrating a multi-band antenna with up to four resonant frequencies will now be described by way of example.

The antenna 1001 of Figure 27 comprises two slotted PIFA antennas 1001a, 1001b disposed on a substrate 1002 mounted (mounting not shown) to a PCB 1003 of a radio communication device. The antenna / substrate 1001/1002 are generally rectangular in shape and lie above and parallel to the major face 1003a of the larger rectangular main PCB 1003.

The first slotted PIFA antenna 1001a is the same as the antenna 101 of Figure 7 and the antenna reference numbers 103 – 113 have corresponding reference numbers 1003 – 1013. The second slotted PIFA antenna 1001b is the same as the mirror image of the antenna 201 in Figure 12 about a vertical axis. The antenna reference numbers 203-213 have corresponding reference numbers 1103-1113. The substrates 1002a and 1002b of the antennas 1001a and 1001b respectively are connected via a non-conductive strip 1019

(Figures 27 and 28) to form a single unitary substrate 1002. The open ends of the slots 1004 and 1104 open into the non-conductive strip 1019 and face one another. The antennas feed circuits 1009, 1010 and 1109, 1110 are indicated with dashed lines (Figure 28) and may be combined using matching
5 circuitry (not shown) to provide impedance matching between the radio circuitry and the antennas 1001a and 1001b. Alternatively it may be advantageous for the feeds to be kept separate and fed directly to suitable radio circuitry, e.g. a switch (not shown).

10 It will be appreciated that in a further embodiment the substrates 1002a and 1002b need not be joined by the non-conductive strip 1019 so that the antennas 1001a and 1001b exist as separate structures (not shown). In another embodiment it will be appreciated that the open ends of the slot need not face one another but may be offset from one another (not shown).

15 The antenna 1001 has $\frac{1}{4}$ wavelength resonant frequencies at 950MHz (1001a) and 970MHz (1001b) and $\frac{3}{4}$ wavelength resonant frequencies at 2700MHz (1001b) and 2780MHz (1001a), as shown in Figure 29. The $\frac{1}{4}$ wavelength resonant frequencies of antennas 1001a and 1001b are close
20 enough so that they overlap to form a single wider bandwidth resonant frequency, centred at 960MHz (Figure 29). The antenna 1001 will therefore have three distinct resonant frequencies. It will be appreciated that altering the geometry of the slots 1004 and 1104 can result in the antenna 1001 having both the $\frac{1}{4}$ wavelength and the $\frac{3}{4}$ wavelength resonant frequencies
25 overlapping to form two wider bandwidth resonant frequencies (not shown) (in the case where the geometries of 1001a and 1001b are substantially similar). It will also be appreciated that altering the geometry of the slots 1004 and 1104 can result in the antenna 1001 having no overlapping resonant frequencies and therefore having four distinct resonant frequencies
30 (not shown) (in the case where the geometries of 1001a and 1001b are substantially different).

In a further embodiment an antenna 1201, which is the same as the antenna 1001 of Figure 27 except that the feed structures 1009, 1010 and 1109, 1110

have been removed and replaced by a single feed structure 1209, 1210. References 1001-1019 and 1102-1119 have corresponding references 1201-1219 and 1302-1319. The antenna 1201 has a single feed 1209,1210 positioned midway between the antennas 1201a and 1201b and lying
5 beneath the non-conductive strip 1219 (Figure 30).

In each of the cases shown, the open-ended slot geometry forms a polygon determined so as the sum of the interior angles excluding the open end is not 540 degrees.

10

It will be appreciated that many modifications may be made to the preferred embodiment described above. For instance, the antenna could be made symmetrical to give a reduced bandwidth but better matching characteristics. In addition, it will be appreciated that one or more of the various
15 embodiments may be combined.

Claims

1. A method of independently modifying the $\frac{1}{4}$ and/or the $\frac{3}{4}$ wavelength resonant frequency in an open-ended slotted PIFA antenna, an open-ended
5 slotted PIFA antenna comprising
an antenna ground associated with the antenna short-circuit end, and
an open-ended slot having an open-end associated with the antenna open-circuit end, and
wherein the antenna ground and the slot are mutually arranged to
10 provide operational variations in the current density between the open and short circuit ends of the antenna and around the perimeter of the slot, and to provide an operational mean current path length between the open and short circuit ends of the antenna and around the perimeter of the open-ended slot,
15 the mean current path length determining the $\frac{1}{4}$ and $\frac{3}{4}$ wavelength resonant frequencies for the open-ended slotted PIFA antenna,
the method comprising determining operational variations in current density around the perimeter of a pre-modified open-ended slotted PIFA antenna and modifying the mean current path length around the perimeter of the pre-modified open-ended slot in regions of comparatively high current
20 density.
2. The method according to claim 1, wherein the method is arranged to modify the mean current path length to provide a post-modified slotted PIFA antenna with an increased $\frac{1}{4}$ wavelength resonant frequency compared to
25 the pre-modified slotted PIFA antenna.
3. The method according to claim 1, wherein the method is arranged to modify the mean current path length to provide a post-modified slotted PIFA antenna with a decreased $\frac{1}{4}$ wavelength resonant frequency compared to the
30 pre-modified slotted PIFA antenna.
4. The method according to claim 1, wherein the method is arranged to modify the mean current path length to provide a post-modified slotted PIFA

antenna with an increased $\frac{3}{4}$ wavelength resonant frequency compared to the pre-modified slotted PIFA antenna.

5 5. The method according to claim 1, wherein the method is arranged to modify the mean current path length to provide a post-modified slotted PIFA antenna with a decreased $\frac{3}{4}$ wavelength resonant frequency compared to the pre-modified slotted PIFA antenna.

10 6. The method according to claim 1, wherein the method comprises modifying the mean current path length in regions of maximum current density.

15 7. The method according to claim 1, wherein the method comprises increasing the mean current path length in regions of maximum current density.

20 8. The method according to claim 1, wherein the method comprises decreasing the mean current path length in regions of maximum current density.

9. The method according to claim 1, wherein the method comprises modifying the mean current path length by modifying the slot perimeter in the regions of comparatively high current density.

25 10. The method according to claim 1, wherein the method comprises modifying the mean current path length by increasing the slot perimeter in the regions of comparatively high current density.

30 11. The method according to claim 1, wherein the method comprises modifying the mean current path length by decreasing the slot perimeter in the regions of comparatively high current density.

12. The method according to claim 1, wherein the method comprises modifying the mean current path length by providing one or more additional slot branches in high current density regions.
- 5 13. The method according to claim 1, wherein the method comprises modifying the mean current path length by providing one or more additional notches within the slot in high current density regions.
- 10 14. A method of designing an open-ended slotted PIFA antenna according to the method of claim 1.
- 15 15. An open-ended slotted PIFA antenna produced by the method of claim 1.
16. A open-ended slotted PIFA antenna produced by the method of claim 1, wherein the post-modified slotted PIFA antenna has a $\frac{1}{4}$ and $\frac{3}{4}$ wavelength resonant frequencies having a ratio of 1 : not 3.
- 20 17. A open-ended slotted PIFA antenna produced by the method of claim 1, wherein the coupling effects are low compared to geometrical effects in providing a $\frac{1}{4}$ and $\frac{3}{4}$ wavelength resonant frequencies having a ratio of 1 : not 3.
- 25 18. An open-ended slotted PIFA antenna having a $\frac{1}{4}$ and $\frac{3}{4}$ wavelength resonant frequency, the open-ended slotted PIFA antenna comprising
an antenna ground associated with the antenna short-circuit end, and
an open-ended slot having an open-end associated with the antenna open-
30 circuit end, and
wherein the antenna ground and the slot are mutually arranged to provide operational variations in the current density between the open and short circuit ends of the antenna and around the perimeter of the slot and to provide an operational mean current path length between the open and short
35 circuit ends of the antenna and around the perimeter of the open-ended slot,

the mean current path length determining the $\frac{1}{4}$ and $\frac{3}{4}$ wavelength resonant frequencies for the open-ended slotted PIFA antenna,

and wherein the geometry of the antenna is such that the $\frac{1}{4}$ and $\frac{3}{4}$ wavelength resonant frequencies of the antenna are in a ratio 1: not 3, this
5 ratio not being substantially attributable to coupling effects.

19. The antenna according to claim 18, wherein the geometry of the antenna comprises the geometry of the slot.

10 20. The antenna according to claim 18, wherein the geometry of the antenna is the geometrical shape of the slot and the relative position of the antenna short/open circuit ends to the geometrical shape of the slot.

21. A multi-band antenna according to claim 18.

15 22. An antenna as hereinbefore described with reference to the accompanying figures.

20 23. A method of independently modifying an open-ended slotted PIFA antenna as hereinbefore described and with reference to the accompanying figures.

24. A method of designing an open-ended slotted PIFA antenna as hereinbefore described and with reference to the accompanying figures.

25

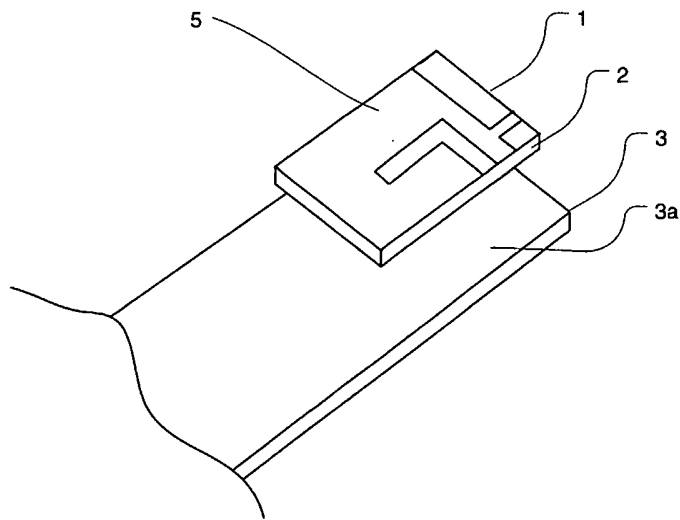

Figure 1

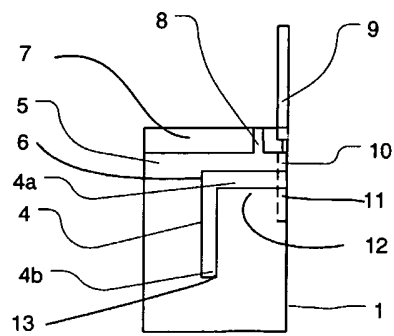

Figure 2

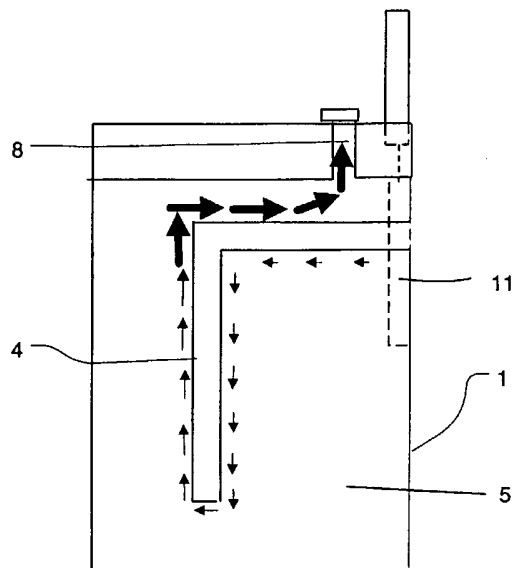

Figure 3

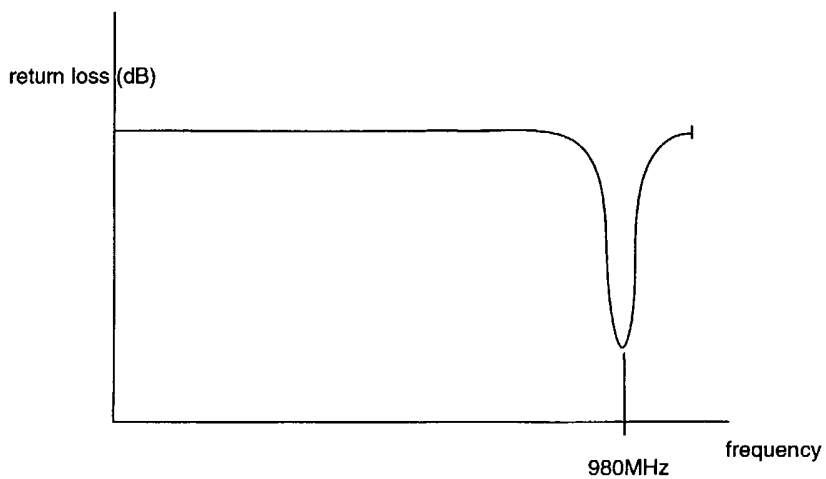

Figure 4

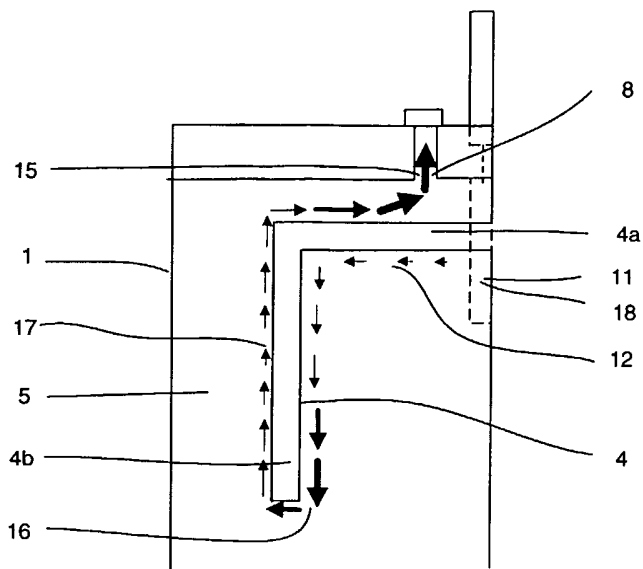

Figure 5

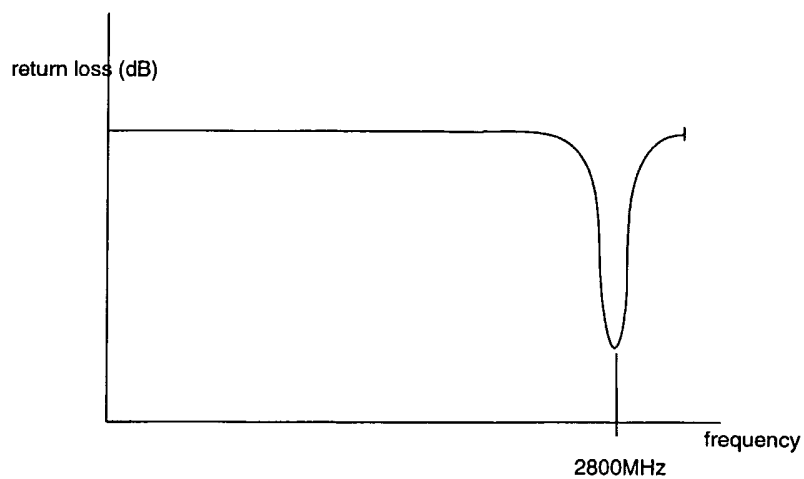

Figure 6

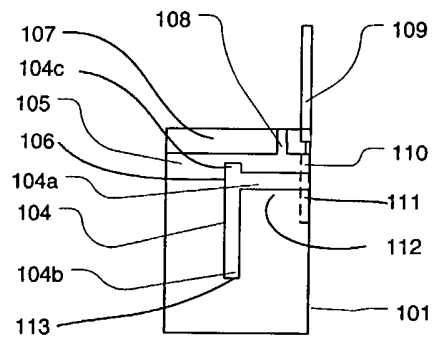

Figure 7

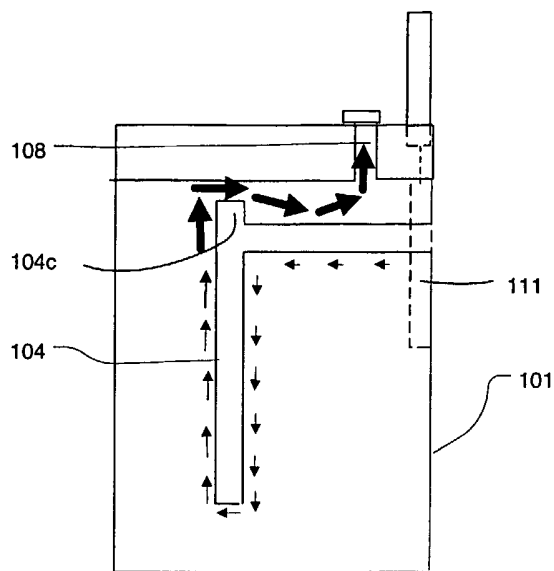

Figure 8

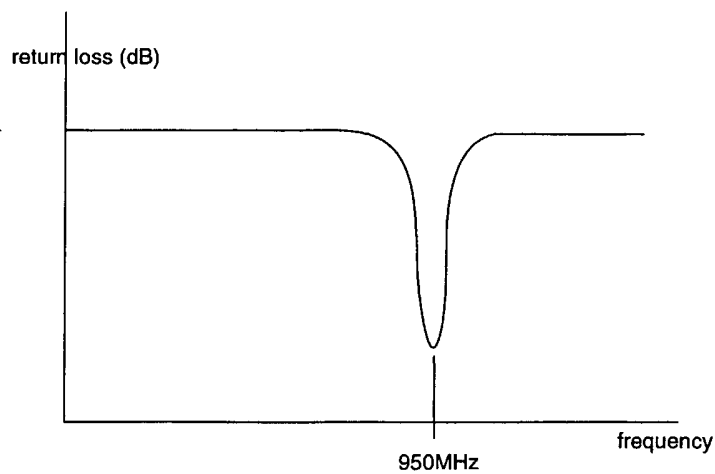

Figure 9

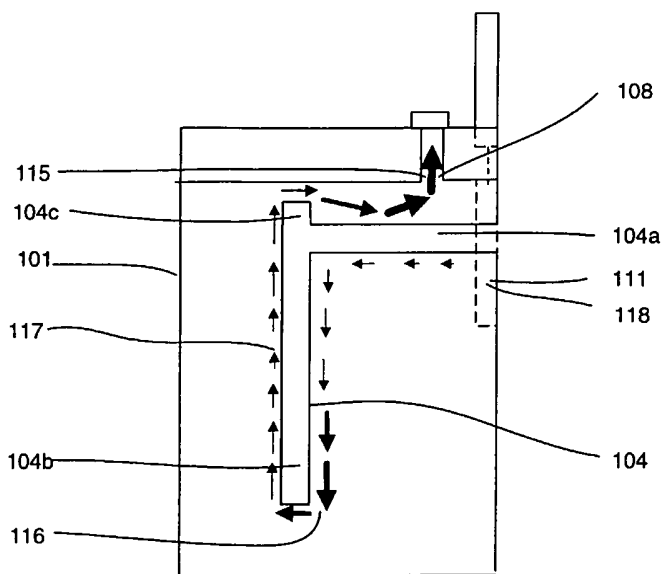

Figure 10

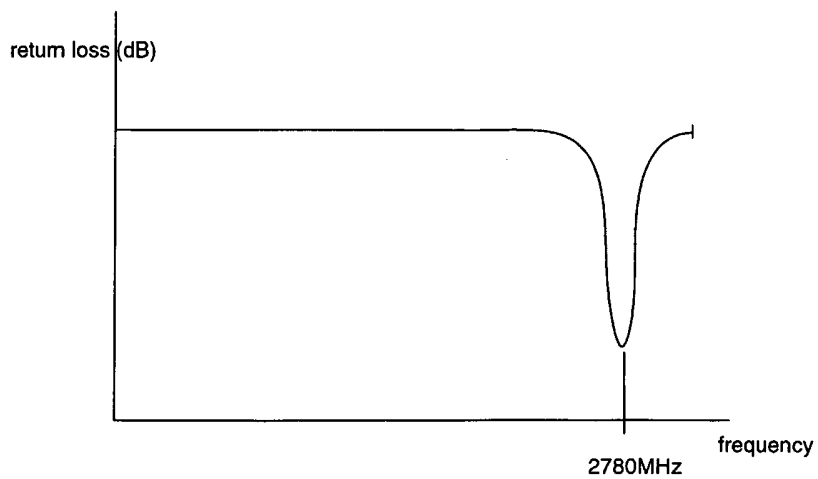

Figure 11

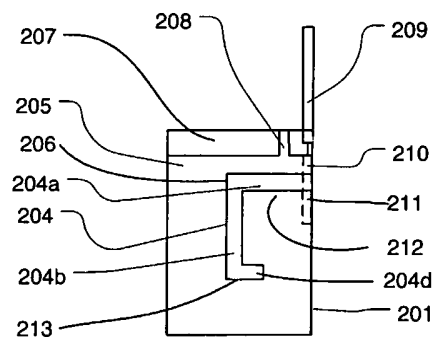

Figure 12

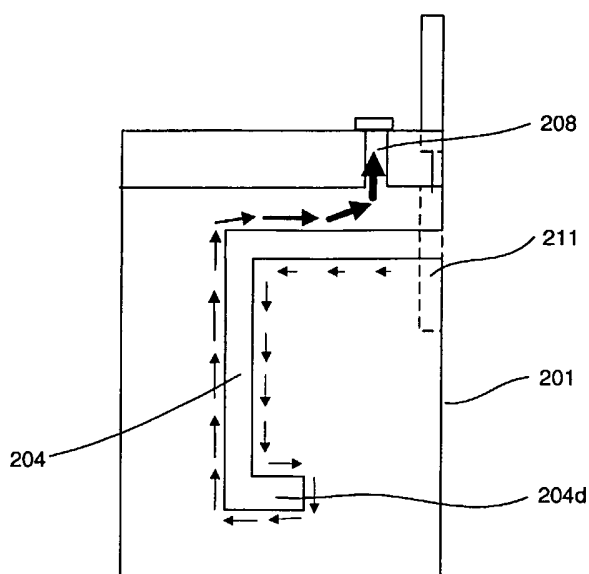

Figure 13

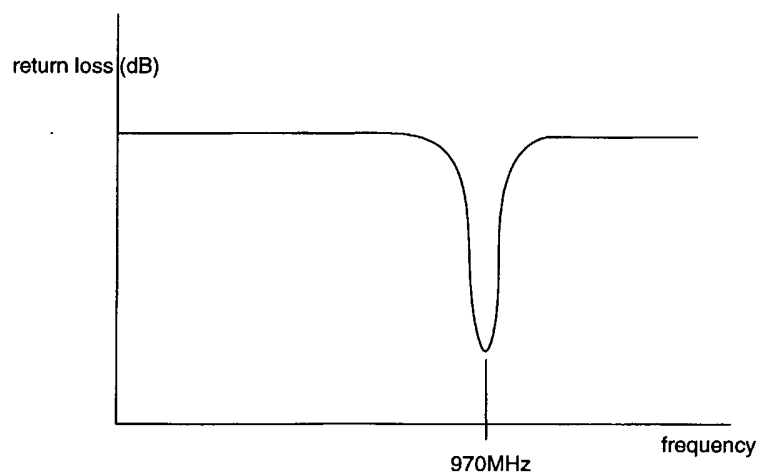

Figure 14

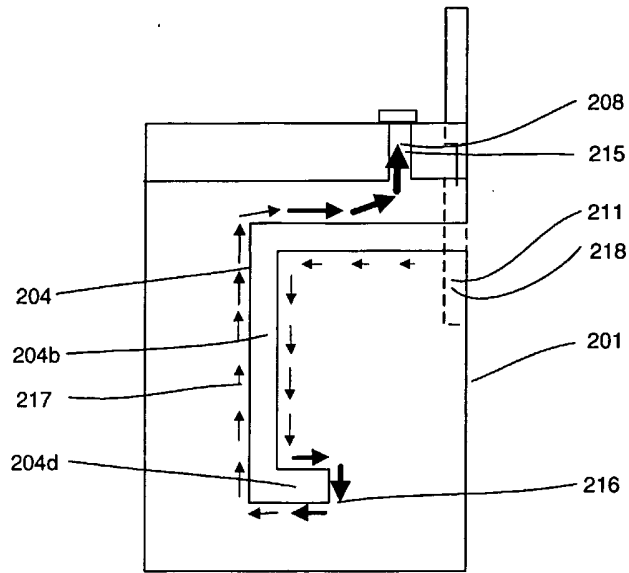

Figure 15

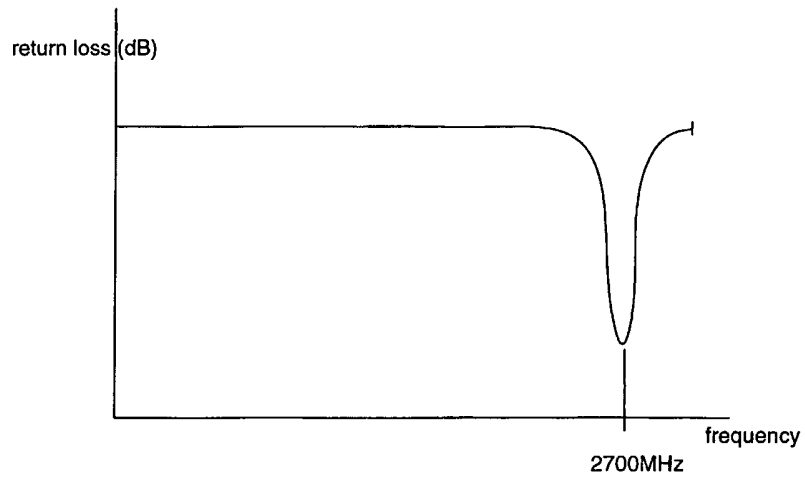

Figure 16

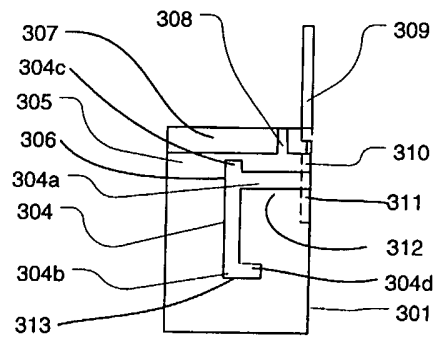

Figure 17

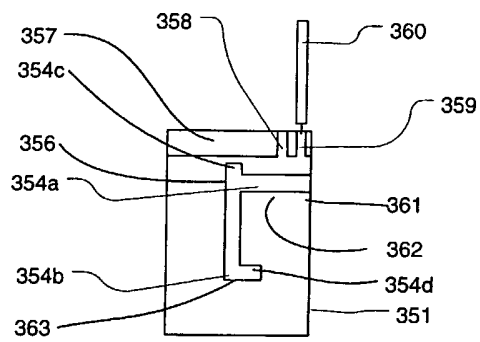

Figure 17(a)

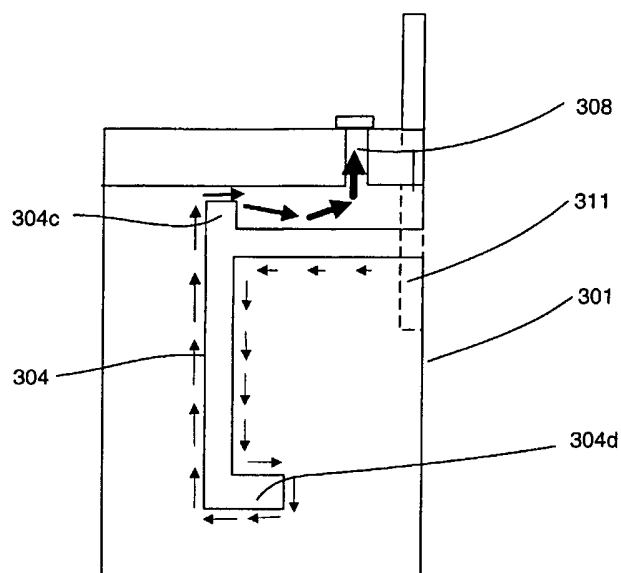

Figure 18

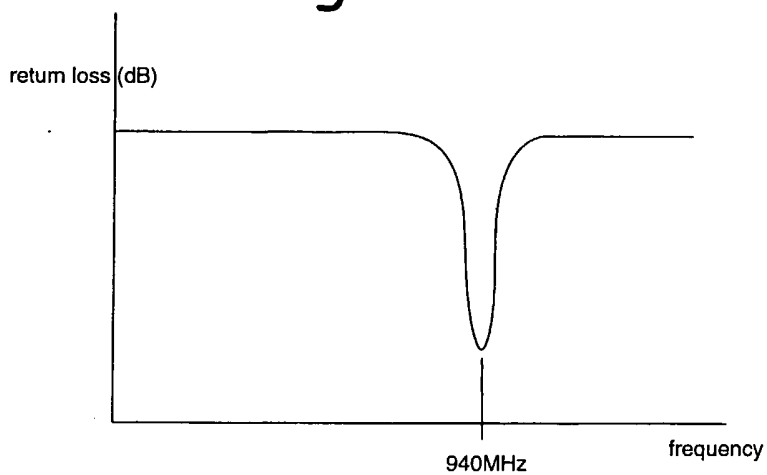

Figure 19

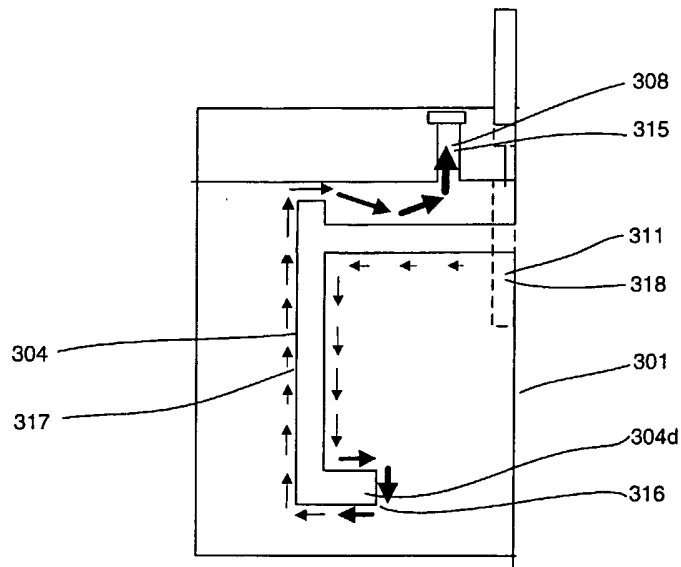

Figure 20

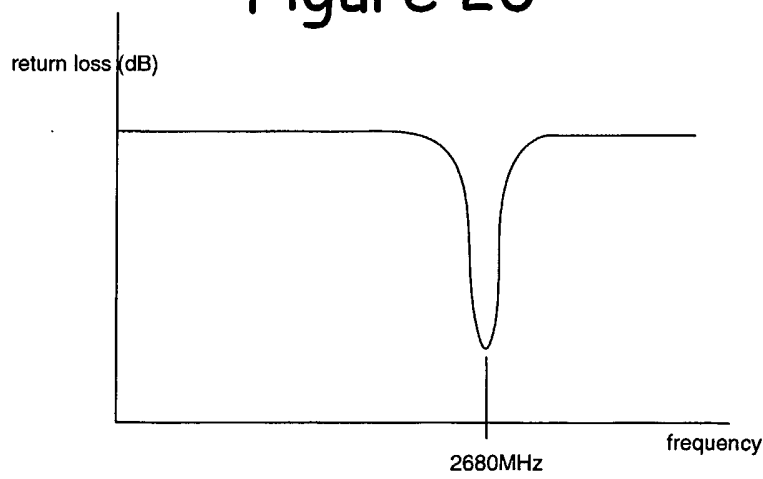

Figure 21

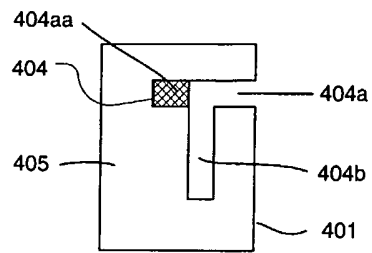

Figure 22

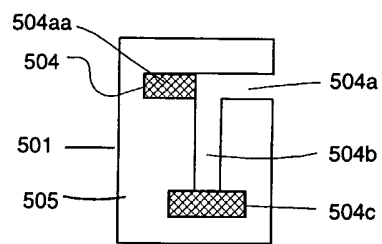

Figure 23

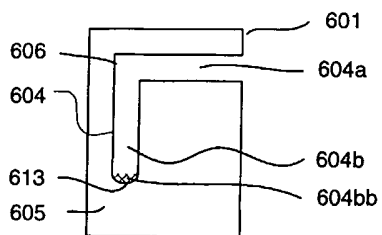

Figure 24

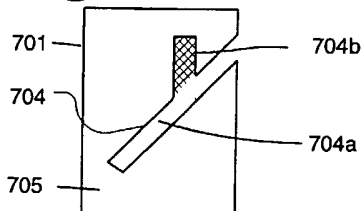

Figure 25

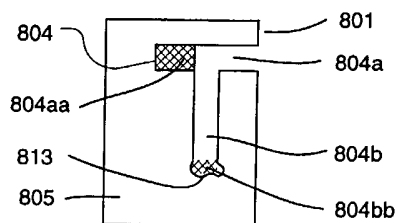

Figure 26

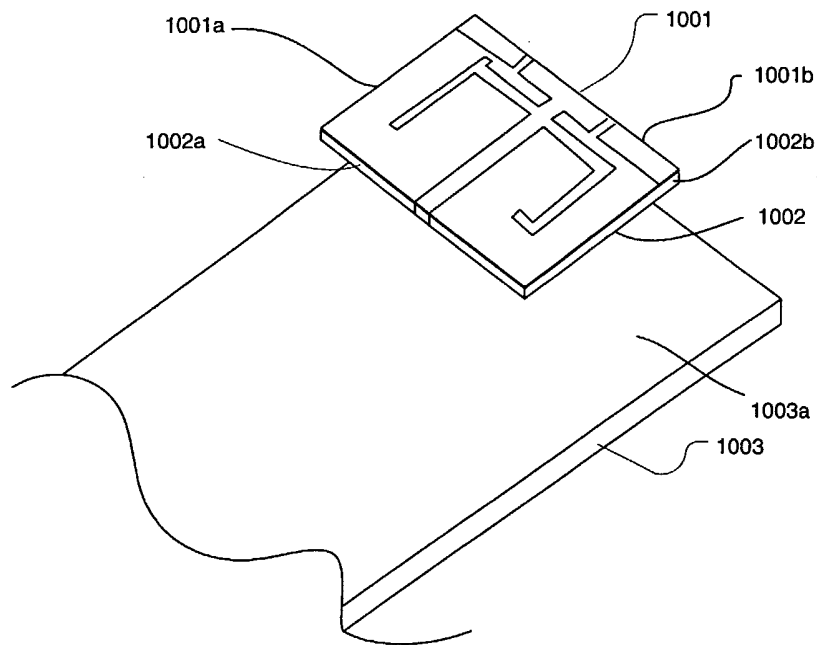

Figure 27

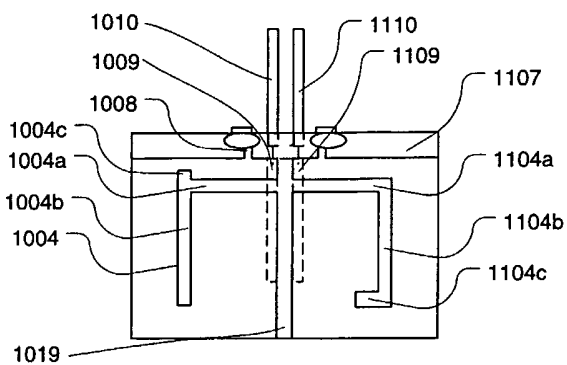

Figure 28

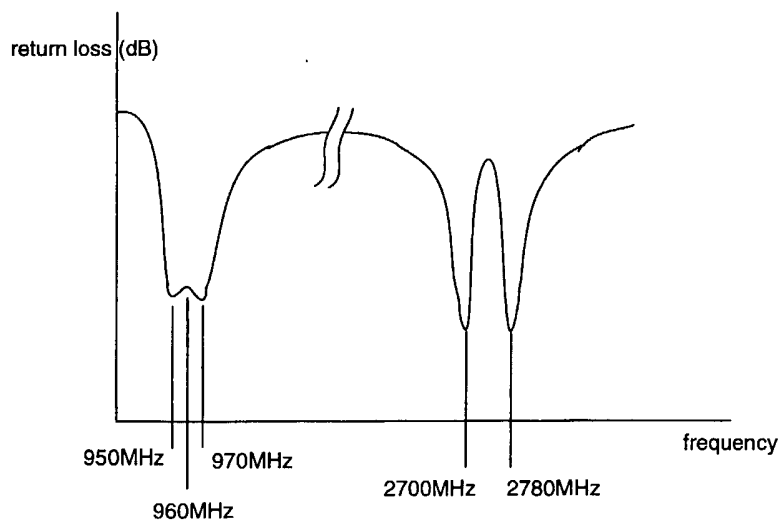

Figure 29

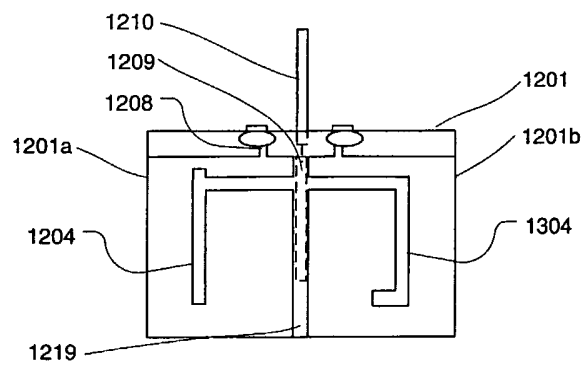

Figure 30

INTERNATIONAL SEARCH REPORT

International Application No
PCT/EP2004/050599

A. CLASSIFICATION OF SUBJECT MATTER

IPC 7 H01Q9/04 H01Q5/00 H01Q1/24

According to International Patent Classification (IPC) or to both national classification and IPC

B. FIELDS SEARCHED

Minimum documentation searched (classification system followed by classification symbols)
IPC 7 H01Q

Documentation searched other than minimum documentation to the extent that such documents are included in the fields searched

Electronic data base consulted during the international search (name of data base and, where practical, search terms used)

EPO-Internal, PAJ, WPI Data, INSPEC, COMPENDEX

C. DOCUMENTS CONSIDERED TO BE RELEVANT

Category °	Citation of document, with indication, where appropriate, of the relevant passages	Relevant to claim No.
X	SALONEN P ET AL: "New slot configurations for dual-band planar inverted-F antenna" MICROWAVE AND OPTICAL TECHNOLOGY LETTERS, JOHN WILEY, NEW YORK, NY, US, vol. 28, no. 5, 23 January 2001 (2001-01-23), pages 293-298, XP002245702 ISSN: 0895-2477	1-11, 14-24
Y	paragraphs '0001! - '0003! -----	12, 13
Y	EP 1 304 765 A (FILTRONIC LK OY) 23 April 2003 (2003-04-23) column 3, line 29 - column 6, line 13 figures 2a-6 abstract ----- -/--	12, 13

Further documents are listed in the continuation of box C.

Patent family members are listed in annex.

° Special categories of cited documents:

- | | |
|---|---|
| <ul style="list-style-type: none"> *A* document defining the general state of the art which is not considered to be of particular relevance *E* earlier document but published on or after the international filing date *L* document which may throw doubts on priority claim(s) or which is cited to establish the publication date of another citation or other special reason (as specified) *O* document referring to an oral disclosure, use, exhibition or other means *P* document published prior to the international filing date but later than the priority date claimed | <ul style="list-style-type: none"> *T* later document published after the international filing date or priority date and not in conflict with the application but cited to understand the principle or theory underlying the invention *X* document of particular relevance; the claimed invention cannot be considered novel or cannot be considered to involve an inventive step when the document is taken alone *Y* document of particular relevance; the claimed invention cannot be considered to involve an inventive step when the document is combined with one or more other such documents, such combination being obvious to a person skilled in the art. * & * document member of the same patent family |
|---|---|

Date of the actual completion of the international search

26 July 2004

Date of mailing of the international search report

03/08/2004

Name and mailing address of the ISA

European Patent Office, P.B. 5818 Patentlaan 2
NL - 2280 HV Rijswijk
Tel. (+31-70) 340-2040, Tx. 31 651 epo nl,
Fax: (+31-70) 340-3016

Authorized officer

von Walter, S-U

INTERNATIONAL SEARCH REPORT

International Application No
PCT/EP2004/050599

C.(Continuation) DOCUMENTS CONSIDERED TO BE RELEVANT

Category °	Citation of document, with indication, where appropriate, of the relevant passages	Relevant to claim No.
A	FU-REN HSIAO ET AL: "A dual-band planar inverted-F patch antenna with a branch-line slit" MICROWAVE AND OPTICAL TECHNOLOGY LETTERS, JOHN WILEY, NEW YORK, NY, US, vol. 32, no. 4, 20 February 2002 (2002-02-20), pages 310-312, XP002246573 ISSN: 0895-2477 the whole document	1,18
A	----- JUNG-HYO KIM ET AL: "Frequency tuning of slot-loaded rectangular patch antenna with tuning stubs and gaps" IEEE ANTENNAS AND PROPAGATION SOCIETY INTERNATIONAL SYMPOSIUM. 2001 DIGEST. APS. BOSTON, MA, JULY 8 - 13, 2001, NEW YORK, NY : IEEE, US, vol. VOL. 1 OF 4, 8 July 2001 (2001-07-08), pages 298-301, XP010564287 ISBN: 0-7803-7070-8 the whole document	1-24
A	----- WO 01/08257 A (INTEGRA ANTENNAS LTD ; AVANTEGO AB (SE); ROWELL CORBETT (US)) 1 February 2001 (2001-02-01) page 5, line 11 - page 7, line 2 figures 3-5 abstract -----	12,13

INTERNATIONAL SEARCH REPORT

International Application No

PCT/EP2004/050599

Patent document cited in search report		Publication date		Patent family member(s)		Publication date
EP 1304765	A	23-04-2003	FI	20012045 A		23-04-2003
			CN	1414809 A		30-04-2003
			EP	1304765 A2		23-04-2003
			US	2003076268 A1		24-04-2003

WO 0108257	A	01-02-2001	AU	6331600 A		13-02-2001
			WO	0108257 A1		01-02-2001
