

19



Europäisches Patentamt
European Patent Office
Office européen des brevets



11 Publication number:

0 408 168 B1

12

EUROPEAN PATENT SPECIFICATION

45 Date of publication of patent specification: **08.06.94** 51 Int. Cl.⁵: **C23C 8/02, C23C 8/24**

21 Application number: **90302232.5**

22 Date of filing: **01.03.90**

54 **Method of pretreating metallic works and method of nitriding steel.**

30 Priority: **10.07.89 JP 177660/89**
22.12.89 JP 333424/89

43 Date of publication of application:
16.01.91 Bulletin 91/03

45 Publication of the grant of the patent:
08.06.94 Bulletin 94/23

84 Designated Contracting States:
DE FR GB NL

56 References cited:
EP-A- 0 352 061
DD-B- 152 947
GB-A- 2 153 855

73 Proprietor: **DAIDOUSANSO CO., LTD.**
20-16, Higashishinsaibashi 1-chome,
Chuo-ku
Osaka-shi, Osaka 542(JP)

72 Inventor: **Tahara, Masaaki**
35-4, Miyanakawahara 5-chome
Takatsuki-shi, Osaka 569(JP)
Inventor: **Tomoda, Takakazu**
Koudan Ozaki 14-402,
285-1, Ozaki,
Hannancho
Sennan-gun, Osaka 599-02(JP)
Inventor: **Kitano, Kenzo**
1498-1, Oyamadacho
Kawachinagano-shi, Osaka 586(JP)
Inventor: **Minato, Teruo**
38-2, Shiroyamadai, 3-chome
Hashimoto-shi, Wakayama 648(JP)

74 Representative: **Marlow, Nicholas Simon et al**
Reddie & Grose
16, Theobalds Road
London WC1X 8PL (GB)

EP 0 408 168 B1

Note: Within nine months from the publication of the mention of the grant of the European patent, any person may give notice to the European Patent Office of opposition to the European patent granted. Notice of opposition shall be filed in a written reasoned statement. It shall not be deemed to have been filed until the opposition fee has been paid (Art. 99(1) European patent convention).

Description

FIELD OF THE INVENTION

5 This invention relates to (I) a method of pretreating metallic articles or works for the purpose of cleaning and activating the surface thereof prior to (1) diffusion/penetration processing, such as boronizing, carburization or nitriding, (2) hard ceramic coating formation, for example by physical vapor deposition or thermal spraying, or (3) plating, for example by hot dipping in a molten aluminum or zinc bath and (II) a method of nitriding steel for the improvement of wear resistance and other properties by forming a nitrided layer on
10 the steel surface.

BACKGROUND OF THE INVENTION

15 Prior to being subjected to thermal diffusion/penetration treatment, coating treatment to form hard ceramic coatings, plating treatment or the like thermal surface treatment, metallic works made of steel, aluminum, titanium or nickel, for instance, are generally subjected to various types of pretreatment, for example cleaning, degreasing, acid pickling and treatment with a molten flux. Thus, for example, alkali degreasing and/or cleaning with an organic solvent is selectively applied to carbon steel works before such thermal treatment as carburization or nitriding. For nitriding or the like thermal treatment of stainless steel
20 works, a step of removing surface oxidized layers by washing with a hydrofluoric acid-nitric acid mixture is added to the above-mentioned pretreatment step or steps. In the case of such thermal treatment as physical vapor deposition (PVD) or chemical vapor deposition (CVD) for forming hard ceramic coating layers, such intermediate processing as nickel plating is conducted as a pretreatment step in some instances for improving the adhesion of coating layers to substrate metallic works. For such thermal
25 treatment as plating treatment in a molten zinc or aluminum bath, substrate works are pretreated with a molten flux following degreasing and acid pickling to thereby realize an increased surface activity, or substrate works are maintained at a temperature above the contemplated thermal treatment temperature for a certain period of time and then gaseous hydrogen or a gas containing a high concentration of hydrogen is introduced into the system for reducing the substrate work surface in the resulting reducing atmosphere to
30 achieve the same purpose. The primary object of these pretreatment processes is to activate the surface of substrate metallic works to thereby facilitate the thermal treatment proper and produce maximum treatment effects. However, recent regulations against waste water discharge, regulations against the use of fluorocarbon species, aggravated working conditions and other factors have made it difficult to continue the commercial use of most of the above-mentioned pretreatment processes and have caused increases in
35 pretreatment cost year by year. Furthermore, the pretreatment process comprising maintaining substrate steel works in a reducing gas atmosphere at an elevated temperature prior to plating treatment using molten zinc or aluminum not only requires an expensive reducing gas in large quantities but also involves the problem that the efficiency of plating is impaired by selective oxidation of valuable elements contained in steel materials, for example Mn, Si and Al. It is not easy to maintain such elements in a completely reduced
40 state in the temperature range not higher than 780 °C as compared with Fe, Zn and the like; such elements are susceptible to oxidation and are readily oxidized in the temperature range of about 500-600 °C. As a result, there arises the above-mentioned problem, namely the plating efficiency decreases due to oxidation.

45 As mentioned hereinabove, the prior art pretreatment processes to be applied to substrate metallic works before the subsequent thermal treatment proper still encounter such problems as increases in pretreatment cost, environmental pollution problems and deterioration of performance characteristics of metallic materials themselves. Solution of these problems is earnestly desired.

On the other hand, the methods of nitriding or carbonitriding steel articles or works for the formation of a nitrided layer on their surface which have been so far employed for the purpose of improving their
50 mechanical properties, such as wear resistance, corrosion resistance and fatigue strength, include the following, among others:

- (a) The method using a molten cyanate or cyanide salt, such as NaCNO or KCN (tufftriding method);
- (b) The glow discharge nitriding method (ionitriding method); and
- (c) The method using ammonia or a mixed gas containing ammonia and a carbon source, for example
55 RX gas (gas nitriding or gas soft nitriding method).

Among these, method (a), which uses hazardous molten salts, has a dark future when evaluated from the labor environment, waste treatment and other viewpoints. Method (b), which achieves nitriding by means of glow discharge in an N₂ + H₂ atmosphere under a low degree of vacuum, can indeed avoid, to a

considerable extent, the staining of the steel surface or the influences of oxidized layer formation owing to some cleaning effect of sputtering but tends to allow occurrence of uneven nitriding due to local temperature differences. In addition, this method is disadvantageous in that articles or works which can be nitrided are much limited in shape and size and that increases in cost result. Method (c) also has problems, for instance, the treatment process is not very stable but tends to lead to uneven nitriding. Another problem lies in that deep nitriding requires a fairly long time.

Generally, steel is nitrided at temperatures not lower than 500 °C. For the adsorption and diffusion of nitrogen on the steel surface layer, it is desired that the surface should be free not only of organic and inorganic contaminants but also of any oxidized layer or adsorbed O₂ layer. It is also necessary that the steel surface layer itself should be highly active. The above-mentioned oxidized layer, if present, would unfavorably promote dissociation of the nitriding gas ammonia. In practice, however, it is impossible to prevent oxidized layer formation in gas nitriding. For instance, even in the case of case hardened steel or structural steel whose chromium content is not high, thin oxidized layers are formed even in an high concentration hydrogen atmosphere or an NH₃ or NH₃ + RX atmosphere at temperatures not higher than about 500 °C. This tendency becomes more pronounced with steel species containing an element or elements which have high affinity for oxygen, for example chromium, in large amounts. Works made of this kind of steel must be deprived of inorganic and organic contaminants prior to nitriding by degreasing with an alkaline cleaning solution or washing with an organic solvent such as trichloroethylene. However, in view of the recent regulations against environmental pollution (regulations against destruction of the ozone layer), the use of organic solvents with highest cleaning effects should be avoided and this is another problem.

The oxide formation on the steel surface, such as mentioned above, varies in extent depending on the surface state, working conditions and other factors even in one and the same work, resulting in unevenly nitrided layer formation.

For example, in the typical case of work hardened austenite stainless steel works, satisfactory nitrided layer formation is almost impossible even if passive surface coat layers are completely removed prior to charging into a treatment furnace by cleaning with a hydrofluoric acid-nitric acid mixture. Uneven nitriding occurs not only in gas soft nitriding but also in nitriding of nitriding steel or stainless steel with ammonia alone (gas nitriding). Furthermore, in the case of works complicated in geometry, for example gears, even when they are made of ordinary structural steel, it is a fundamental problem that there is a general tendency to uneven nitriding.

The means or methods so far proposed for solving the above-mentioned essential problems encountered in gas nitriding and gas soft nitriding include, among others, the one comprising charging a vinyl chloride resin into a furnace together with works, the one comprising sprinkling works with chlorine, CH₃Cl or the like and heating at 200-300 °C to thereby cause evolution of HCl and prevent oxide formation and remove oxides therewith, and the one comprising plating works in advance to thereby prevent oxide formation. Practically none of them have been put into practical use, however. Where chlorine or a chloride is used, chlorides such as FeCl₂, FeCl₃ and CrCl₃ are formed on the steel surface. These chlorides are very fragile at temperatures below the nitriding temperature and can readily sublime or vaporize, damaging furnace materials badly. In particular, CrCl₃ can sublime very readily, so that Cr deficiency may readily result in addition to the drawbacks mentioned above. Furthermore, the handling of the above-mentioned chlorides and the like is troublesome, although they are effective to some extent in preventing oxidized layer formation. Thus, none of the methods mentioned above can be said to be practicable.

EP 0 352 061, published after the priority date, but before the filing date of the present application discloses a metal material having on its surface a film passivated by fluorination, the film being composed mainly of a metal fluoride substantially satisfying stoichiometric ratio. An apparatus comprising the metal material is also disclosed.

OBJECTS OF THE INVENTION

Accordingly, it is the first object of the invention to provide a method of pretreating metallic works for cleaning and activating the surface thereof to thereby facilitate the succeeding thermal treatment proper, without causing environmental pollution or increases in pretreatment cost and without impairing performance characteristics of metallic materials, and it is the second object of the invention to provide a method of nitriding steel by which a uniformly nitrided layer can be formed on the steel surface without unevenness in nitriding.

SUMMARY OF THE INVENTION

To accomplish the first object, the invention provides a method of pretreating metallic works which comprises holding a metallic work in a heated condition in a fluorine- or fluoride-containing gas atmosphere and then removing the resulting fluorinated layer to thereby clean and activate the surface of said metallic work and to accomplish the second object, the invention provides a method of nitriding steel by reacting the surface of steel articles or works with nitrogen for the formation of a hard nitrided layer thereon which comprises preliminarily holding a steel work in a fluorine- or fluoride-containing gas atmosphere and, after formation of a fluorinated layer on the surface of the work, heating the steel work in a nitriding atmosphere for the formation of a nitrided layer on the surface thereof.

BRIEF DESCRIPTION OF THE DRAWINGS

Fig. 1 schematically shows, in cross section, an example of the treatment furnace for use in the practice of the invention;

Fig. 2 is a schematic representation of a cross-sectional photomicrograph (magnification: 50) of a surface layer portion of a work pretreated by the method of the invention and then subjected to thermal treatment (nitriding) in Example 1;

Fig. 3 is a schematic representation of a cross-sectional photomicrograph (magnification: 50) of a surface layer portion of a work pretreated and then subjected to thermal treatment (nitriding) as described in Comparative Example 1;

Fig. 4 is a schematic representation of a cross-sectional electron micrograph (magnification: 500) of a portion of the thread ridge of a work pretreated and nitrided as described in Example 1;

Fig. 5 schematically shows, in cross section, another example of the furnace to be used in the practice of the invention;

Fig. 6 is an enlargement of the circled portion A of Fig. 5; and

Fig. 7 schematically shows, in cross section, a plasma CVD furnace suited for use in the practice of the invention.

Fig. 8 shows the sectional hardness distribution in a work treated in accordance with the invention.

DETAILED DESCRIPTION OF THE INVENTION

As a result of a series of investigations made by the present inventors in an attempt to develop a method by which the surface of metallic works can be perfectly cleaned and at the same time activated, and a method of nitriding steel by which a uniformly nitrided layer can be formed on the steel surface without unevenness in nitriding, it has been found that when metallic works are heated in a furnace and, at an elevated temperature thus attained, their surface is brought into contact with a fluorine- or fluoride-containing gas introduced into said furnace, the resulting activated fluorine atoms decompose and remove from said surface foreign matters adhering thereto, for example processing aids, and thus clean said surface and, at the same time, the oxide layer on the metallic work surface is removed and instead a fluorinated layer is formed and protects said surface. Where H_2 and H_2O are absent, this fluorinated layer is stable and continues covering and protecting the metallic work surface at temperature of about $300^\circ C$ - $600^\circ C$. Such fluorinated layer is formed on the furnace inside wall surface as well and covers and protects said wall surface, so that corrosion and wear of the furnace inside wall surface can be prevented.

In addition to the above-mentioned fluorine- or fluoride-containing gases, there are also available chloride gases, such as CH_3Cl (chloromethane) and HCl (hydrogen chloride). However, these chloride gases react with metallic works to give such chloride compounds as $FeCl_2$, $CrCl_2$ and $CrCl_3$. Since these reaction product chlorides are highly sublimable as compared with the corresponding fluorides, showing, for instance, a 100 thousand-fold higher vapor pressure, the so-called chromium (Cr) deficiency (loss of Cr atoms as $CrCl_2$ from the metal work surface layer and the resulting Cr shortage and marked decreases in corrosion resistance and so on) may result and, in addition, chloride-containing gases resulting from vaporization of the above-mentioned readily vaporizable chlorides will erode the furnace inside wall surface and increase the wear thereof. Therefore, they are not suited for practical use.

In accordance with the invention, the oxidized layer occurring on the metallic work surface is removed and a fluoride layer is formed instead. This fluoride layer covers and protects the metallic work surface. Such effects of the invention are particularly significant when the subsequent thermal treatment, for example a treatment for nitriding steel, is conducted at a temperature not higher than $700^\circ C$. The reason is as follows. Metal elements, such as Cr, Mn, Si and Al, contained in metallic works, for example steel works, are

readily oxidizable in the above temperature range. Since it is difficult to produce an atmosphere in which these metal elements can remain perfectly neutral or reducing, the metal elements mentioned above are mostly oxidized in the above temperature range and intergranular oxides are formed on the metal work surface in the step of thermal treatment proper and serve as obstacles to the intended thermal treatment. In accordance with the invention, metallic works are submitted to each intended thermal treatment, with their surface protected with a fluorinated layer and, therefore, any problem of the above kind will not arise.

The fluorinated layer covering and protecting the metallic work surface in the above manner can be eliminated, prior to the step of thermal treatment proper, by, for example, introducing into the furnace, which is maintained at a temperature of about 480-700 °C, an H₂-containing gas, such as an H₂-containing inert gas or a mixture of a nitrogen source gas (e.g. NH₃ gas) and H₂ to thereby cause destruction of the fluorinated layer by means of H₂ contained in said gas. In this manner, the original surface, now clean and active, appears, and a hard coating, for instance, is formed thereon with good adhesion in the subsequent thermal treatment step. For example, in the case that the thermal treatment is a nitriding treatment of steel, uniform nitrided layer can be formed.

In the following, the invention is described in more detail.

In accordance with the invention, the metallic work surface is subjected to pretreatment with a fluorine- or fluoride-containing gas and subsequent thermal treatment such as treatment for nitriding steel.

The term "fluorine- or fluoride-containing gas" as used herein means a dilution of at least one fluorine source component selected from the group consisting of NF₃, BF₃, CF₄, HF, SF₆, and F₂ in an inert gas such as N₂. Among the above-mentioned fluorine source compounds, NF₃, BF₃, CF₄ and F₂ are gaseous at ordinary temperature while SF₆ occurs as a liquid at ordinary temperature. They are admixed, either singly or in combination, with an inert gas, such as N₂, to give fluorine- or fluoride-containing gases to be used in the practice of the invention. Among the fluorine source components mentioned above, NF₃ is most suited for practical use since it is superior in safety, reactivity, controllability, ease of handling and other aspects to the other. F₂ is not so preferable since it has extremely high reactivity and toxicity, is inferior in ease of handling and makes it difficult to operate the furnace smoothly. Generally, the fluorine- or fluoride-containing gases are used in an elevated temperature atmosphere and, therefore, even the fluorine source component SF₆, which is liquid at ordinary temperature, is vaporized and mixed with the inert gas under the conditions of use. From the efficacy viewpoint, the fluorine- or fluoride-containing gases should contain the fluorine source components, such as NF₃, in a concentration within the range of 0.05% to 20% (on the weight basis; hereinafter the same shall apply), preferably from 0.1 to 10%, more preferably 2% to 7%, still more preferably 3% to 5%.

As examples of the metallic works that can be pretreated in accordance with the invention, there may be mentioned steel works, aluminum works, titanium works and nickel works. Said steel works include works made of various steel species, for example carbon steel and stainless steel. The metallic works may vary in shape or form and in dimensions. Thus, for example, they may be in the form of plates or sheets, coils, screws or some other machined articles. The metallic works to which the method of the invention is applicable may be made not only of one of such metallic materials as mentioned above but also of an alloy derived from the above-mentioned materials by appropriate combination, with or without addition of another or other minor component metallic materials.

In accordance with the invention, the metallic works mentioned above are pretreated, for example, as follows. The metallic works are placed in a heating furnace and heated to a temperature of 150-600 °C, preferably 300-500 °C. Then, in that state, a fluorine- or fluoride-containing gas is introduced into the heating furnace. The metallic works are held at the above-mentioned temperature in an fluorine- or fluoride-containing gas atmosphere for about 10-120 minutes, preferably about 20-90 minutes, more preferably 30-60 minutes, whereby the oxidized layer on the metallic work surface is removed and a fluorinated layer is formed on said surface. An H₂-containing inert gas is then introduced into the heating furnace for decomposing and eliminating the fluorinated layer. As a result, a cleaned and activated metallic material surface reveals itself. This series of steps may be performed, for example, in a heat treatment furnace such as the one shown in Fig. 1. In the figure, the furnace 1 is a pit furnace and has a heater 3 provided in the space between an outer shell 2 and an inner vessel 4, with a gas inlet pipe 5 being inserted in said vessel. Gas supply is made from cylinders 15 and 16 via flow meters 17 and a valve 18. The inside atmosphere is stirred by means of a fan 8 driven by a motor 7. Works 10 placed in a wire net container 11 are charged into the furnace 1. The furnace is provided with an exhaust pipe 6, a vacuum pump 13 for exhaustion, and a noxious substance eliminator 14.

In this heat treatment furnace 1, the pretreatment procedure is carried out as follows. The metallic works 10 charged in the furnace 1 as shown in Fig. 1 are heated by means of the heater 3 to a predetermined temperature. A fluorine- or fluoride-containing gas, for example a mixed gas composed of

NF₃ and N₂, is introduced into the furnace 1 from the cylinder 15, whereby processing aids and the like adhering to the surface of the metallic works 10 are removed and at the same time the oxidized layer possibly occurring on the surface of the metallic works 10 is removed and a fluorinated layer is formed instead. As a result, the surface of the metallic works 10 is covered and protected by the fluorinated layer.

5 After such pretreatment of the metallic works 10 in the furnace 1, the fluorine- or fluoride-containing gas in the furnace 1 is discharged from the furnace through the exhaust pipe 6 by applying vacuum. The metallic works 10 are then heated by the heater 3 to a further elevated temperature of 480-700 °C. In that state, a mixed gas composed of N₂ and H₂ is blown into the furnace from the cylinder 16, whereby the fluorinated layer is eliminated. As a result, the metallic works 10 reveal a clean and active metallic surface. This
10 surface undergoes various kinds of treatment process in the subsequent thermal treatment step. In this case, thermal treatment proper, for example diffusion/penetration treatment, can be applied to the surface of the metallic works 10 deeply and uniformly, since said surface has now been cleaned and activated. In hard ceramic coating or plating, a uniform and closely adhering coating layer or metal deposit layer can be formed. The fluorinated layer may be eliminated simultaneously with thermal treatment proper. For
15 example, in the nitriding treatment of steel, pretreatment and thermal treatment proper are carried out simultaneously. That is, steel works are cleaned for degreasing, for instance, and then charged into a heat treatment furnace 1 such as shown in Fig. 1. And a fluorine- or fluoride-containing reaction gas, for example a mixed gas composed of NF₃ and N₂, is introduced into this furnace. In this case, the concentration of NF₃ should amount to, for example, 10,000~100,000ppm, preferably 20,000 ~70, 000ppm, more preferably
20 30,000 ~50,000ppm. The holding time of the works in such fluorine- or fluoride-containing gas atmosphere may appropriately be selected depending on the steel species, geometry and dimensions of the works, heating temperature and so forth, generally within the range of ten and odd minutes to scores of minutes. Thus, after putting the works into the above-mentioned gas atmosphere, the works are heated at a specified reaction temperature. At temperatures of 250-400 °C, NF₃ evolves fluorine in the nascent state, whereby the
25 organic and inorganic contaminants on the steel work surface are eliminated therefrom and at the same time this fluorine rapidly reacts with the base elements Fe and chromium on the surface and/or with oxides occurring on the steel work surface, such as FeO, Fe₃O₂ and Cr₂O₃. As a result, a very thin fluorinated layer containing such compounds as FeF₂, FeF₃, CrF₂ and CrF₄ in the metal structure is formed on the surface, for example as follows:

30

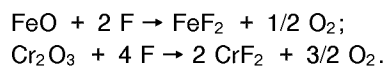

These reactions convert the oxidized layer on the work surface to a fluorinated layer. At the same time,
35 O₂ adsorbed on the surface is removed therefrom. Where O₂, H₂ and H₂O are absent, such fluorinated layer is stable at temperatures up to 600 °C and can presumably prevent oxidized layer formation on the metal base and adsorption of O₂ thereon until the subsequent step of nitriding. A fluorinated layer, which is similarly stable, is formed on the furnace material surface as well and minimizes the damage to the furnace material surface.

40 The works thus treated with such fluorine- or fluoride-containing reaction gas are then heated at a nitriding temperature of 480-700 °C. Upon addition of NH₃ or a mixed gas composed of NH₃ and a carbon source gas (e.g. RX gas) in the heated condition, the fluorinated layer undergoes destruction to give an active metal base.

Upon formation of such active metal base, active N atoms are adsorbed thereon, then enter the metal
45 structure and diffuse the rein and, as a result, a layer (nitrided layer) containing such nitrides as CrN, Fe₂N, Fe₃N and Fe₄N is formed on the surface.

A layer containing such compounds is formed in the prior art processes as well. In the known processes, however, the surface activity of the works is reduced by oxidized layer formation and O₂ adsorption during the period of temperature rise from ordinary temperature to the nitriding temperature.
50 Therefore, in the nitriding step, the adsorption of N atoms on the surface is low in degree and uneven. Such unevenness in N adsorption is promoted by the fact that it is practically impossible to maintain a uniform extent or rate of decomposition of NH₃ in the furnace. In the process according to the invention, N atoms are adsorbed on the work surface uniformly and rapidly, hence the problem mentioned above is never encountered.

55 From the operational process viewpoint, it is an outstanding feature of the invention that, as a result of the use, as the reactant gas for fluorinated layer formation, of such a gaseous substance as NF₃, which shows no reactivity at ordinary temperature and can be handled with ease, the process is simplified, for example continuous treatment becomes possible, as compared with the processes which involve plating

treatment or use of PVC, which is a solid, or a liquid chlorine source. The tufftriding process can hardly be said to have a bright future since a great expenditure is required for work environment improvement and environmental pollution prevention, for instance, although it is excellent in promoting nitrided layer formation and increasing fatigue strength, among others. On the contrary, the above-mentioned process according to the invention requires only a simple device for eliminating hazardous substances from the exhaust waste gas, and allows at least the same extent of nitrided layer formation as in the tufftriding process and thereby makes it possible to avoid uneven nitriding. While nitriding is accompanied by carburizing in the tufftriding process, it is possible to perform nitriding alone in the process according to the invention.

In this way, when nitriding treatment is performed as the subsequent thermal treatment, an extremely hard compound layer (nitrided layer) containing such nitrides as CrN, Fe₂N, Fe₃N and Fe₄N is formed uniformly and deeply from the surface of the metallic works toward the inside thereof. Therebelow a hard N atom diffusion layer is formed deeply. Such mode of nitriding is very efficient. However, as mentioned hereinbefore, the subsequent thermal treatment is not limited to such nitriding. For instance, the method of the invention is effective in performing such processing treatments as carbonitriding, physical vapor deposition (PVD) and chemical vapor deposition (CVD), which are to be carried out at or below 700 °C. In these cases, the pretreatment for fluorinated layer formation should preferably be conducted in a furnace other than the furnace in which the thermal treatment proper is carried out. Other examples of the subsequent thermal treatment for which the method of the invention is effective are plating treatments using molten zinc or aluminum. While these treatments generally include a complicated series of steps, namely alkali degreasing, acid pickling, molten flux treatment and dipping in molten aluminum or zinc, the pretreatment stage from alkali degreasing to molten flux treatment can be markedly simplified when the method of pretreatment according to the invention is employed. As a result, the length of the overall process can be shortened and the production cost can be reduced. Furthermore, particularly in plating works made of a high Si content steel species, the method of the invention can produce a favorable effect in that a metal deposit layer superior in adhesion can be formed.

As mentioned above, the method of pretreating metallic works according to this invention comprises holding metallic works in a heated state in a fluorine- or fluoride-containing gas atmosphere so that active fluorine atoms supplied by the fluorine- or fluoride-containing gas can act on the metallic work surface, cleaning the same by destructing and eliminating processing aids and other foreign matters adhering thereto and at the same time removing the surface oxidized layer therefrom and forming a fluorinated layer instead. This fluorinated layer can serve as a protective coating on the surface of the metallic works. The fluorinated layer can be decomposed and eliminated in a step just prior to or in the subsequent thermal treatment step by means of an H₂-containing gas, whereby an uncoated and activated metallic work surface can appear. Thus, although a certain period of time may be required from the pretreatment to the thermal treatment, the pretreatment method of this invention does not cause the unfavorable phenomenon that a new oxidized layer is formed on the pretreated metallic work surface. This is because the fluorinated layer formed after removal of the oxidized layer from the metallic work surface covers and protects said surface. Thus, in accordance with the pretreatment method of the invention, the oxide layer on the metallic work surface is converted to a fluorinated layer, which can be readily decomposable and removable, so that the metallic work surface can be converted to an uncovered and activated state. This is an outstanding feature of the invention.

The steel nitriding method according to the invention comprises holding steel works with heating in a fluorine- or fluoride-containing gas atmosphere to thereby eliminate organic and inorganic contaminants and at the same time cause the passive coat layer, such as an oxidized layer, on the steel work surface to be converted to a fluorinated layer, and then subjecting the works to nitriding treatment. Since the oxidized layer or the like passive coat layer on the steel work surface is converted to a fluorinated layer in that manner, the steel work surface is protected in a good state. Therefore, even after the lapse of a certain period from the time of fluorinated layer formation to the time of nitriding, the fluorinated layer formed on the steel work surface remains in a good condition, still protecting the steel work surface. As a result, no oxidized layer can be formed again on the steel work surface. In the subsequent nitriding treatment, such fluorinated layer is decomposed and eliminated, whereby a new steel work surface appears. This newly exposed metal surface is in an active condition, allowing N atoms to penetrate readily into the steel works subjected to nitriding treatment. The resulting uniform penetration of N atoms from the steel work surface into the depth leads to formation of a favorable nitrided layer. In particular, the fluorine- or fluoride-containing gas to be used in accordance with the invention in the pretreatment step prior to nitriding treatment is a gas which shows no reactivity at ordinary temperature and can be handled with ease, for example NF₃, and therefore the pretreatment step can be simplified by carrying out the step in a continuous manner, for instance.

BEST MODES FOR CARRYING OUT THE INVENTION

(1) Examples of the method of pretreating metallic works

5 Example 1

[Pretreatment]

SUS 305 tapping screws (samples) were shaped and then cleaned with vaporized trichloroethylene. They were charged into such a furnace 1 as shown in Fig. 1 and heated to a temperature of 350 °C. In that state, a fluoride-containing gas composed of 7.0% of NF₃ and 93.0% of N₂ was introduced into the furnace 1 and the resulting system was maintained at 350 °C for 20 minutes. Then, some of the above-mentioned samples were taken out and examined for their surface structure. It was confirmed that a fluorinated layer had been formed all over the surface.

15 [Thermal treatment]

The samples remaining in the furnace 1 were heated to 550 °C, held in an N₂ + 90% H₂ atmosphere for 30 minutes and then subjected to 5 hours of nitriding treatment by introducing into the furnace 1 a mixed gas composed of 50% NH₃, 10% CO₂ and 40% N₂. In this treatment process, the fluorinated layer was decomposed and eliminated and at the same time a nitrided layer was formed. The thus-nitrided samples were air-cooled and taken out of the furnace.

A uniform nitrided layer had been formed on the surface of the samples obtained.

25 Comparative Example 1

The same tapping screw samples as used in Example 1 were cleaned with vaporized trichloroethylene, pretreated by dipping in a hydrofluoric acid-nitric acid mixture for 30 minutes, charged into the same furnace 1 as used in Example 1, and subjected to nitriding treatment in a mixed gas composed of 50% NH₃ and 50% RX (H₂, CO) for 5 hours.

The samples obtained in Example 1 were compared with those obtained in Comparative Example 1 with respect to the state of the nitrided layer and to the hardness distribution. The results are summarized below in tabular form. The sectional photomicrographic views (magnification: 50) of the samples obtained in Example 1 and Comparative Example 1, respectively taken in the vicinity of the surface, are schematically shown in Fig. 2 and Fig. 3, respectively. The sectional electron micrographic view (magnification: 500) of the thread of a sample obtained in Example 1 is schematically shown in Fig. 4. In Figs. 2-4, the letter A indicates the base metal and B the nitrided layer.

	Example 1	Comparative Example 1
State of nitrided layer	Nitrided layer uniform in thickness formed all over the surface.	No nitrided layer formation in many parts; nitrided layer, if formed, found only in thread top portions
Hardness:		
Surface hardness of nitrided layer B (Hv)	1150-1200	310-320
Hardness of the inside (base metal) A (Hv)	270-290	270-290

Example 2

55 [Pretreatment]

A fragment of a very low carbon steel strip (Si content: 1.5%; Mn content: 0.5%) was used as a sample. The sample was cleaned by alkali degreasing, washed with water and charged into a furnace as shown in

Fig. 5. In Fig. 5, the furnace body 20 including its heat insulating wall has a heating means 21 circumferentially embedded in the furnace body 20. A sliding door 22 closes the bottom of the furnace body 20 is slidable in the left and right directions in the plane shown. The ceiling of the furnace body 20 is equipped with a gas inlet pipe 23 which enables gas introduction into the furnace body 20 containing the sample 24 to be treated. A zinc pot furnace 25 is disposed below the furnace body 20, with the sliding door 22 serving as a partition therebetween. As shown in Fig. 6, the zinc pot furnace 25 has an induction coil 26 embedded in the surrounding wall and contains a zinc bath 27 maintained at 450 °C. The sample charged in such a furnace was heated to 300 °C and then held, for pretreatment, at that temperature in a mixed gas composed of 1% NF₃ and 99% N₂ as introduced into the furnace for 30 minutes. The sample was then heated to 500 °C and held in a mixed gas (75% N₂ + 25% H₂) introduced into the furnace for 10 minutes, whereby the fluorinated layer formed in the pretreatment was eliminated.

[Thermal treatment]

The sliding door 22 was opened and the sample was transferred to the zinc pot furnace 25 and zinc-plated there.

The sample was then taken out of the furnace, whereupon N₂ gas was blown against the sample. The sample was then cooled and dried. Thus was obtained a desired zinc-plated sample.

Comparative Example 2

A fragment of the same very low carbon steel strip as used in Example 2 was cleaned by alkali degreasing, acid pickling and washing with water, then charged into the furnace shown in Fig. 5, and heated to 700 °C. In that state, a mixed gas composed of 25% N₂ and 75% H₂ was blown into the furnace for 20 minutes. Then, the sliding door 22 was opened and the sample fragment was transferred to the zinc pot furnace situated below the furnace 20 and subjected to zinc plating under the same conditions as used in Example 2, followed by blowing N₂ gas against the sample, cooling and drying.

The thus-obtained two steel samples were tested for the adhesion of the zinc metal deposit layer by performing a bending test followed by observation of the bent portion. The sample of Comparative Example 2 which had been heated at 700 °C showed marked insufficiency of metal deposit layer adhesion in places. On the contrary, the sample of Example 2 did not show such a phenomenon. The samples of Example 2 and Comparative Example 2 were subjected to surface analysis by means of an optical microscope, an X ray microanalyzer (EPMA) and an ion microanalyzer (IMA). Selective oxidation to Si_mO_n and Mn_mO_n was observed with the sample of Comparative Example 2 while such phenomenon was not found in the sample of Example 2.

Example 3

[Pretreatment]

An SKH 51 end mill was used as a sample. This was degreased, dried, further subjected to fluorocarbon cleaning and then charged into the furnace shown in Fig. 1. The furnace was evacuated to 0.1-1.3 Pa (10⁻² to 10⁻³ torr) using a vacuum pump while the furnace inside temperature was raised. Then, the temperature was maintained at 280 °C and the pressure at 2.0x10⁴ to 2.7x10⁴ Pa (150 to 200 torr). In that state, a mixed gas composed of 20% NF₃ and 80% N₂ was introduced into the furnace. The sample was held in that state in the mixed gas for 30 minutes, the furnace was then cooled, and the sample was taken out.

[Thermal treatment]

The thus-pretreated sample was placed in such a low temperature plasma CVD furnace as shown in Fig. 7 and subjected to TiN coating by heating at 480 °C for 60 minutes.

In Fig. 7, the reference numeral 30 stands for the sample, 31 for a pump, 32 for a thermometer and 33 for a power source.

The TiN coating layer on the thus-obtained sample had a thickness of 3 μm. The adhesion of this coating layer as measured on a scratch tester was higher by 30% as compared with the adhesion attainable by the plasma CVD technique using the conventional pretreatment methods. The durability of the sample end mill was at least 5 times higher as compared with an uncoated sample.

(II) Examples of the method of nitriding steel

Example 4 and Comparative Example 3

5 Work-hardened SUS 305 stainless steel works (screws) were cleaned with trichloroethylene, then charged into such a treatment furnace 1 as shown in Fig. 1, and held at 300 °C in an N₂ gas atmosphere containing 5,000 ppm NF₃ for 15 minutes. Then they were heated to 530 °C, and nitriding treatment was carried out at that temperature for 3 hours while a mixed gas composed of 50% N₂ was introduced into the furnace. The works were then air-cooled and taken out of the furnace.

10 The nitrided layer of each work thus obtained was uniform in thickness. The surface hardness was 1,100-1,300 Hv while the base material portion had a hardness of 360-380 Hv.

In Comparative Example 3, the same works as used in Example 1 were cleaned with trichloroethylene, treated with a mixture of hydrofluoric acid and nitric acid, placed in the furnace mentioned above, and heated in 75% NH₃ at 530 °C or 570 °C for 3 hours. In either case, great variations were found in the thickness of the nitrided layer formed. The proportion of portions having no nitrided layer at all was high.

15 Photomicrographs of the works obtained in the above-mentioned example and example for comparison, respectively taken in the vicinity of the surface, are shown in Fig. 2 and Fig. 4 (Example) and Fig. 3 (Comparative Example).

20 Example 5

SUS 305 stainless steel tapping screws were cleaned with acetone, placed in the furnace shown in Fig. 1, held in an N₂ atmosphere containing 5,000 ppm of NF₃ at 280 °C for 15 minutes, then heated to 470 °C held in N₂ + 90% H₂ at that temperature for 30 minutes, nitrided in 20% NH₃ + 80% RX for 8 hours, and taken out of the furnace.

25 A 40-50 μm thick nitrided layer was formed all over the screw surface. The surface hardness after surface polishing was Hv = 950-1,100. The nitrided layer showed a corrosion resistance to 5% sulfuric acid which was not so inferior to that of the base material.

30 Example 6 and Comparative Example 4

The works used in Example 6 were hot-worked mold parts polished by emery cloth (SKD 61). They were charged into the furnace shown in Fig. 1, heated in an N₂ atmosphere containing 3,000 ppm of NF₃ at 300 °C for 15-20 minutes, then heated to 570 °C, and treated at that temperature with a mixed gas composed of 50% NH₃ and 50% N₂ for 3 hours. A uniform nitrided layer of a thickness of 120 μm was obtained with a surface hardness of 1,000-1,100 Hv (base material hardness 450-500 Hv).

35 In Comparative Example 4, the same parts as used in Example 6 were cleaned with hydrofluoric acid-nitric acid and then subjected to nitriding treatment at 570 °C for 3 hours. The nitrided layer thickness was at most 90-100 μm and great variations were found in said thickness. Severe surface roughening was also observed.

40 Example 7 and Comparative Example 5

Nitriding steel (SACM 1) parts were cleaned, charged into the furnace shown in Fig. 1, held in an N₂ gas atmosphere containing 5,000 ppm of NF₃ at 280 °C for 20 minutes and then heated in 75% NH₃ at 550 °C for 12 hours. The nitrided layer obtained had a thickness of 0.42mm. For comparison (Comparative Example 5), the same parts as above were nitrided in the conventional manner. The thickness of the nitrided layer was 0.28mm.

50 Example 8

Structural carbon steel (S45C) mold parts were cleaned, held in an atmosphere containing 5,000 ppm of NF₃ at 300 °C for 20 minutes, then treated at 530 °C with 50% NH₃ plus 50% RX for 4 hours, oil-quenched, and taken out. The nitrided layer obtained had a hardness of 450-480 Hv. These works were subjected to a rotary bending test. The fatigue strength was 44Kg/mm², being comparable or superior to that of the products gas soft nitrided in the conventional manner.

Example 9

Work-hardened SUS 305 stainless steel works (screws) were subjected to nitriding treatment in the same manner as in Example 4 except that a mixed gas composed of 10% NH₃, 5% CO and 85% N₂ was used in lieu of the mixed gas composed of 50% NH₃ + 50% N₂.

The nitrided layer of each work thus obtained had a uniform thickness. The depth of the nitrided layer was about 70 μm. The nitrided layer was more compact than that obtained in Example 4. The surface of the nitrided layer of the works thus obtained was polished and subjected to a corrosion test using sodium chloride and sulfuric acid. Still better results were obtained as compared with Example 4.

In this example, the NH₃ concentration in the mixed gas used for nitriding was below 25% and this is presumably why better nitrided layer formation, resulted as compared with the case where the NH₃ concentration exceeded 25%. Particularly when a mixed gas having such composition is used for nitrided layer formation, the nitrided layer comprised of a compound layer containing intermetallic compounds composed of N and Cr, Fe, etc., and a diffusion layer containing nitrogen atoms that have diffused shows a much higher diffusion layer/compound layer ratio, as shown by the curve A in Fig. 5, as compared with the corresponding ratio shown by the curve B for the conventional nitriding processes. This indicates that, in accordance with the invention, nitrided layers are obtained with a very good hardness gradient, which is different from the steep hardness decrease gradient in the prior art. The works nitrided in this example showed practically no difference in hardness between the thread ridge and the bottom.

Example 10

Work-hardened SUS 305 stainless steel works (tapping screws) were cleaned with trichloroethylene, placed in a furnace other than the nitriding furnace, heated to 330 °C, and held in the furnace at that temperature for 40 minutes while mixed gas composed of N₂ gas and 20,000 ppm of NF₃ was introduced into the furnace. The works were then cooled with gaseous nitrogen and taken out of the furnace.

After the lapse of 3 hours, the works were charged into the nitriding furnace, heated at 530 °C and nitrided for 4 hours while feeding a mixed gas composed of 20% NH₃ + 10% CO₂ + N₂ to the furnace.

The works thus obtained had a good and uniform nitrided layer, like the products obtained in Examples 4 and 5.

Example 11 and Comparative Example 6

Work-hardened SCM 440 works (shafts) contaminated with a cutting oil were degreased with an alkali. Without cleaning with any organic solvent, they were placed in the treatment furnace 1, such as shown in Fig. 1, heated to 330 °C, and held at that temperature in an N₂ gas atmosphere containing 30,000 ppm of NF₃ for 3 hours. Then, the temperature was raised to 570 °C while feeding gaseous N₂ in lieu of the mixed gas mentioned above. At that temperature, a mixed gas composed of 50% N₂ + 50% H₂ was fed to the furnace for 40 minutes and then a mixed gas composed of 50% NH₃ + 10% CO₂ + 40% N₂ was introduced into the furnace for effecting nitriding for 3 hours.

In comparative Example 6, the same cutting oil-contaminated work-hardened works as used in Example 11 were subjected to alkali cleaning, then directly charged into the furnace shown in Fig. 1, heated to 570 °C, and nitrided at that temperature for 3 hours while feeding a mixed gas composed of 50% NH₃ + 50% RX to the furnace.

The nitrided layers of both lots of works thus obtained were compared with each other. In Example 11, the nitrided layer had a micro Vickers hardness (Hv) of 350 and nitrided layer depth of 180 μm whereas, in Comparative Example 6, the nitrided layer thickness was 40 μm. It is thus evident that the nitrided layer of the works obtained in Example 11 had a greater depth.

For further comparison, the work-hardened sample works were subjected to alkali cleaning and then further to cleaning with trichloroethylene. Then, they were nitrided in the same manner as in Comparative Example 6 for 3 hours using a mixed gas composed of 50% NH₃ + 50% RX. Even in this case, the nitrided layer thickness could not exceed 95 μm.

Claims

1. A method of pretreating metallic works which comprises holding a metallic work in a heated condition in a fluorine- or fluoride-containing gas atmosphere and then removing the resulting fluorinated layer to thereby clean and activate the surface of the metallic work.

2. A method according to claim 1 in which the metallic work is essentially of steel, aluminium, titanium or nickel.
3. A method according to any preceding claim in which the fluorinated layer is removed by treatment with hydrogen gas, and optionally with a nitrogen source gas.
4. A method according to claim 3 in which the said treatment is carried out at a temperature between 480°C and 700°C.
5. A method according to claim 1 in which the metal is steel, further comprising, after formation of the fluorinated layer on the surface of the steel, heating the steel in a nitriding atmosphere to form a nitrided layer on the surface thereof.
6. A method of nitriding steel by reacting the surface of the steel with nitrogen to form a hard nitrided layer thereon characterised in that the method comprises holding the steel in an atmosphere containing fluorine or fluoride and, after formation of a fluorinated layer on the surface of the steel, heating the steel in a nitriding atmosphere to form the nitrided layer on the surface thereof.
7. A method according to claim 6 in which the nitriding atmosphere comprises ammonia.
8. A method according to claim 6 or 7 in which the nitriding atmosphere comprises ammonia and a gaseous carbon source.
9. A method according to claim 6, 7 or 8 in which the nitriding atmosphere comprises ammonia and nitrogen.
10. A method according to any of claims 6 to 9 in which the steel is heated to a temperature of between 480°C and 700°C in the nitriding atmosphere.
11. A method according to any of claims 6 to 10 in which the fluorinated steel is held in a nitrogen atmosphere prior to exposure to the nitriding atmosphere.
12. A method according to any preceding claim in which the fluorine- or fluoride-containing gas is a dilution, in an inert gas, of at least one of NF_3 , BF_3 , CF_4 , HF , SF_6 and F_2 .
13. A method according to any preceding claim in which the atmosphere containing fluorine or fluoride further comprises an inert gas such as nitrogen.
14. A method according to any preceding claim in which the fluorine- or fluoride containing gas is present in the said atmosphere at a concentration of from 0.05% to 20% by weight, preferably from 0.1% to 10%, more preferably from 2% to 7% by weight, still more preferably from 3% to 5% by weight.
15. A method according to any preceding claim in which the formation of the fluorinated layer is carried out at a temperature between 150°C and 600°C, preferably between 300°C and 500°C.
16. A method according to any preceding claim in which formation of the fluorinated layer is carried out at between 150°C and 350°C.
17. A method according to any preceding claim in which the metal is held in the fluoride- or fluorine-containing gas for from 10 minutes to 120 minutes, preferably from 20 minutes to 90 minutes, most preferably from 30 to 60 minutes.

Patentansprüche

1. Verfahren zur Vorbehandlung von metallischen Werkstücken, welches umfaßt das Halten eines metallischen Werkstückes in einem erhitzten Zustand in einer Fluor oder Fluorid enthaltenden Gasatmosphäre und anschließende Entfernung der fluorierten Schicht, um hierdurch die Oberfläche des metallischen Werkstückes zu reinigen und zu aktivieren.

2. Verfahren nach Anspruch 1, bei welchem das metallische Werkstück im wesentlichen aus Stahl, Aluminium, Titan oder Nickel besteht.
- 5 3. Verfahren nach irgendeinem vorhergehenden Anspruch, bei welchem die fluorierte Schicht durch Behandlung mit Wasserstoffgas und wahlweise mit einem Gas aus einer Stickstoffquelle entfernt wird.
4. Verfahren nach Anspruch 3, bei welchem die Behandlung bei einer Temperatur zwischen 480 und 700 ° C durchgeführt wird.
- 10 5. Verfahren nach Anspruch 1, bei dem das Metall Stahl ist, weiterhin umfassend, nach der Bildung der fluorierenden Schicht an der Oberfläche des Stahls, Erhitzen des Stahls in einer nitrierenden Atmosphäre, um an dessen Oberfläche eine nitrierte Schicht zu bilden.
- 15 6. Verfahren zur Nitrierung von Stahl durch Reagieren der Oberfläche des Stahls mit Stickstoff, um eine harte nitrierte Schicht darauf zu bilden, dadurch gekennzeichnet, daß das Verfahren das Halten des Stahls in einer Atmosphäre, die Fluor oder Fluoride enthält und nach der Bildung einer fluorierten Schicht an der Oberfläche des Stahls Erhitzen des Stahls in einer nitrierenden Atmosphäre umfaßt, um an dessen Oberfläche eine nitrierte Oberfläche zu bilden.
- 20 7. Verfahren nach Anspruch 6, bei dem die nitrierende Atmosphäre Ammoniak enthält.
8. Verfahren nach Anspruch 6 oder 7, dadurch gekennzeichnet, daß die nitrierende Oberfläche Ammoniak und eine gasförmige Kohlenstoffquelle enthält.
- 25 9. Verfahren nach Anspruch 6, 7 oder 8, bei welchem die nitrierende Atmosphäre Ammoniak und Stickstoff enthält.
10. Verfahren nach irgendeinem der Ansprüche 6 - 9, bei welchem der Stahl in der nitrierenden Atmosphäre auf eine Temperatur zwischen 480 und 700 ° C erhitzt wird.
- 30 11. Verfahren nach irgendeinem der Ansprüche 6 - 10, in welchem der fluorierte Stahl in einer Stickstoffatmosphäre gehalten wird, bevor er der nitrierenden Atmosphäre ausgesetzt wird.
- 35 12. Verfahren nach irgendeinem vorhergehenden Anspruch, bei welchem das Fluor oder Fluorid enthaltende Gas eine Verdünnung in einem inerten Gas aus mindestens einem von NF_3 , BF_3 , CF_4 , HF , SF_6 und F_2 ist.
- 40 13. Verfahren nach irgendeinem der vorhergehenden Ansprüche, bei welchem die Fluor oder Fluorid enthaltenden Atmosphäre außerdem ein inertes Gas, wie Stickstoff, enthält.
- 45 14. Verfahren nach irgendeinem der vorhergehenden Ansprüche, bei welchem das Fluor oder Fluorid enthaltende Gas in dieser Atmosphäre in einer Konzentration von 0,05 bis 20 Gew.%, vorzugsweise von 0,1 bis 10%, vorzugsweise von 2 bis 7 Gew.% und am bevorzugtesten von 3 bis 5 Gew.% gegenwärtig ist.
- 50 15. Verfahren nach irgendeinem vorhergehenden Anspruch, bei dem die Bildung der fluorierten Schicht bei einer Temperatur zwischen 150 und 600 ° C, vorzugsweise zwischen 300 und 500 ° C, durchgeführt wird.
16. Verfahren nach irgendeinem vorhergehenden Anspruch, bei dem die Bildung der fluorierten Schicht bei einer Temperatur zwischen 150 und 350 ° C durchgeführt wird.
- 55 17. Verfahren nach irgendeinem vorhergehenden Anspruch, bei welchem das Metall in dem Fluor oder Fluorid enthaltenden Gas für von 10 bis 120 Minuten, vorzugsweise von 20 bis 90 Minuten, am bevorzugtesten von 30 bis 60 Minuten, gehalten wird.

Revendications

- 5 1. Un procédé de prétraitement d'ouvrages métalliques qui consiste à maintenir un ouvrage métallique, à l'état chauffé, dans une atmosphère de gaz contenant du fluor ou un fluorure et à retirer ensuite la couche fluorée résultante en vue de nettoyer et d'activer ainsi la surface de l'ouvrage métallique.
2. Un procédé selon la revendication 1 dans lequel l'ouvrage métallique est essentiellement en acier, aluminium, titane ou nickel.
- 10 3. Un procédé selon l'une des revendications précédentes dans lequel la couche fluorée est retirée par traitement à l'aide d'hydrogène gazeux et, facultativement à l'aide d'une source d'azote gazeux.
4. Un procédé selon la revendication 3 dans lequel ledit traitement a lieu à une température entre 480 ° C et 700 ° C.
- 15 5. Un procédé selon la revendication 1 dans lequel le métal est l'acier, consistant en outre, après formation de la couche fluorée à la surface de l'acier, à chauffer l'acier dans une atmosphère nitrurante en vue de former à sa surface une couche nitrurée.
- 20 6. Un procédé de nitruration de l'acier par réaction de la surface de l'acier avec de l'azote pour y former une couche nitrurée dure, caractérisé en ce que le procédé consiste à maintenir l'acier dans une atmosphère contenant du fluor ou un fluorure et, après formation d'une couche fluorée à la surface de l'acier, à chauffer l'acier dans une atmosphère nitrurante pour former à sa surface une couche nitrurée.
- 25 7. Un procédé selon la revendication 6 dans lequel l'atmosphère nitrurante contient de l'ammoniac.
8. Un procédé selon la revendication 6 ou 7 dans lequel l'atmosphère nitrurante comprend de l'ammoniac et une source de carbone gazeux.
- 30 9. Un procédé selon la revendication 6, 7 ou 8 dans lequel l'atmosphère nitrurante contient de l'ammoniac et de l'azote.
10. Un procédé selon l'une des revendications 6 à 9 dans lequel l'acier est chauffé à une température entre 480 ° C et 700 ° C dans l'atmosphère nitrurante.
- 35 11. Un procédé selon l'une des revendications 6 à 10 dans lequel l'acier fluoré est maintenu dans une atmosphère d'azote avant exposition à l'atmosphère nitrurante.
12. Un procédé selon l'une des revendications précédentes dans lequel le gaz contenant du fluor ou un fluorure est une dilution, dans un gaz inerte, d'au moins un des NF_3 , BF_3 , CF_4 , HF , SF_6 et F_2 .
- 40 13. Un procédé selon l'une des revendications précédentes dans lequel l'atmosphère contenant du fluor ou un fluorure comprend en outre un gaz inerte tel que l'azote.
- 45 14. Un procédé selon l'une des revendications précédentes dans lequel le gaz contenant du fluor ou un fluorure est présent dans ladite atmosphère à une concentration de 0,05% à 20% en poids, de préférence de 0,1% à 10%, plus préférablement de 2% à 7% en poids, plus préférablement encore de 3% à 5% en poids.
- 50 15. Un procédé selon l'une des revendications précédentes dans lequel la formation de la couche fluorée a lieu à une température entre 150 ° C et 600 ° C, de préférence entre 300 ° C et 500 ° C.
16. Un procédé selon l'une des revendications précédentes dans lequel la formation de la couche fluorée a lieu entre 150 ° C et 350 ° C.
- 55 17. Un procédé selon l'une des revendications précédentes dans lequel l'acier est maintenu dans le gaz contenant du fluor ou un fluorure pendant 10 minutes à 120 minutes, de préférence pendant 20 minutes à 90 minutes et mieux encore pendant 30 à 60 minutes.

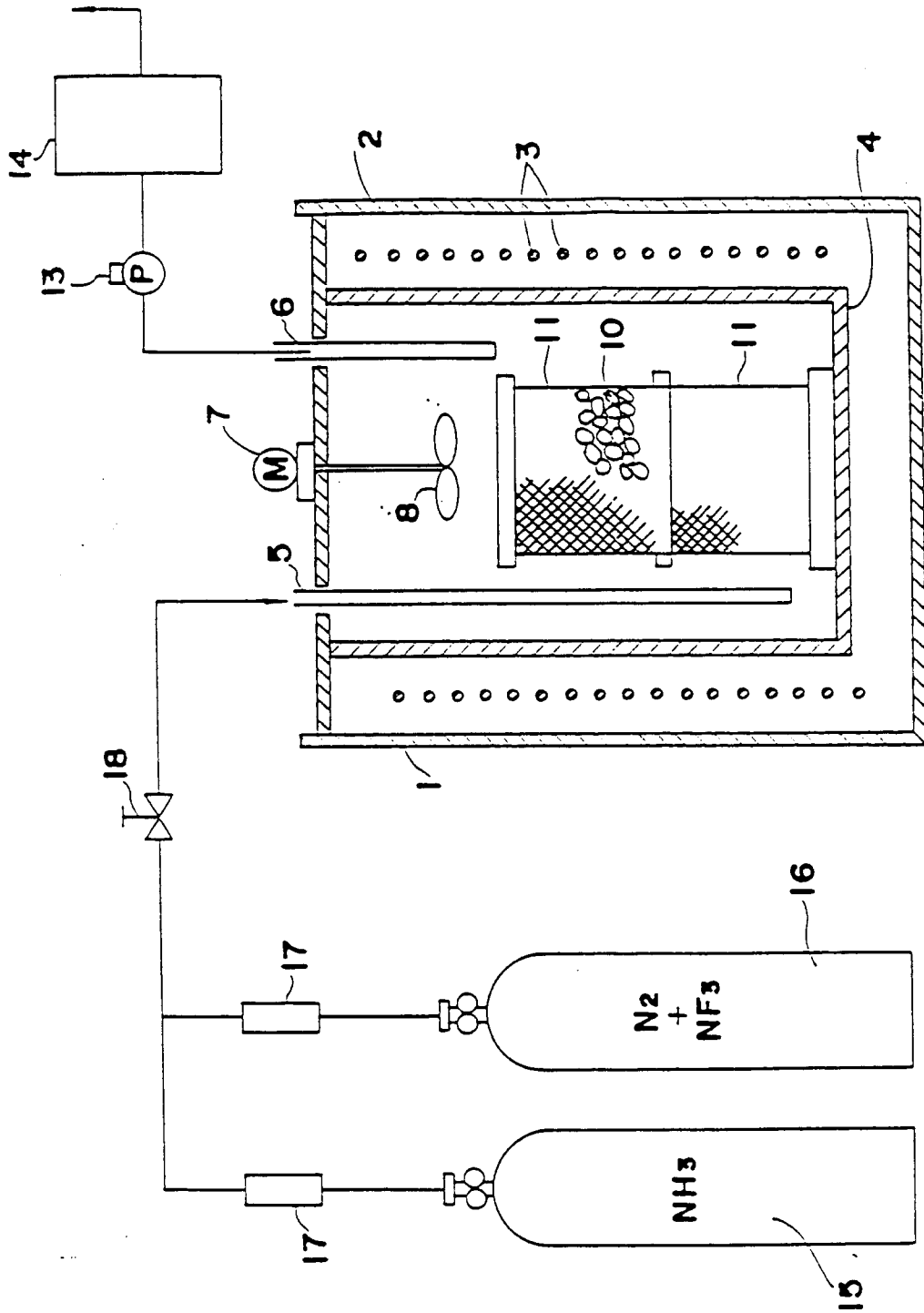

FIG. 1

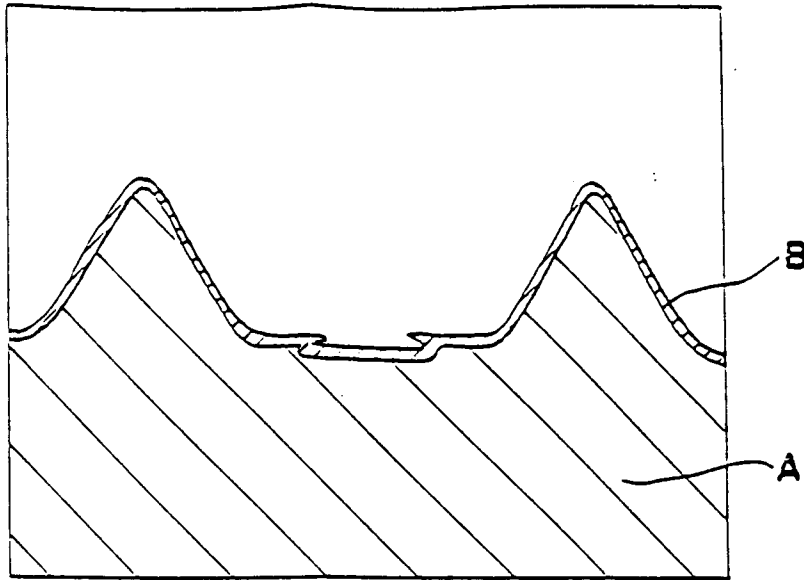

FIG. 2

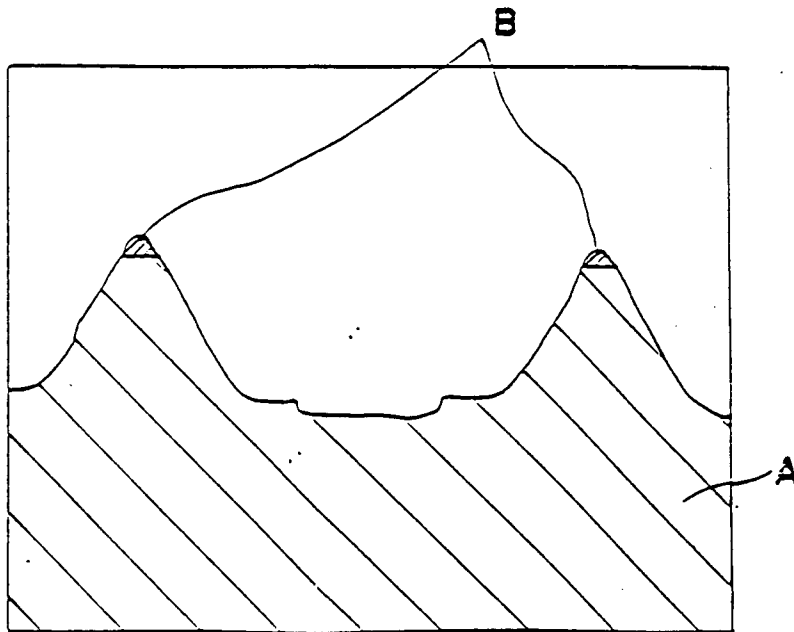

FIG. 3

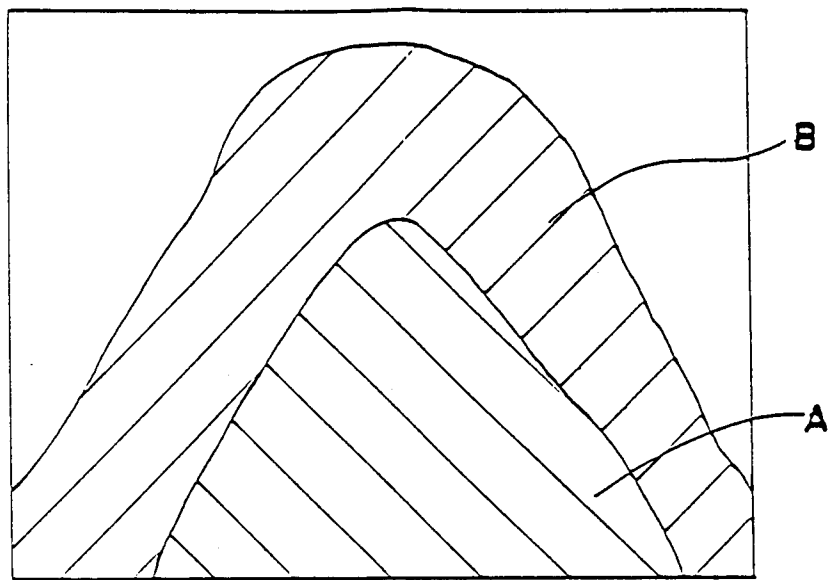

FIG. 4

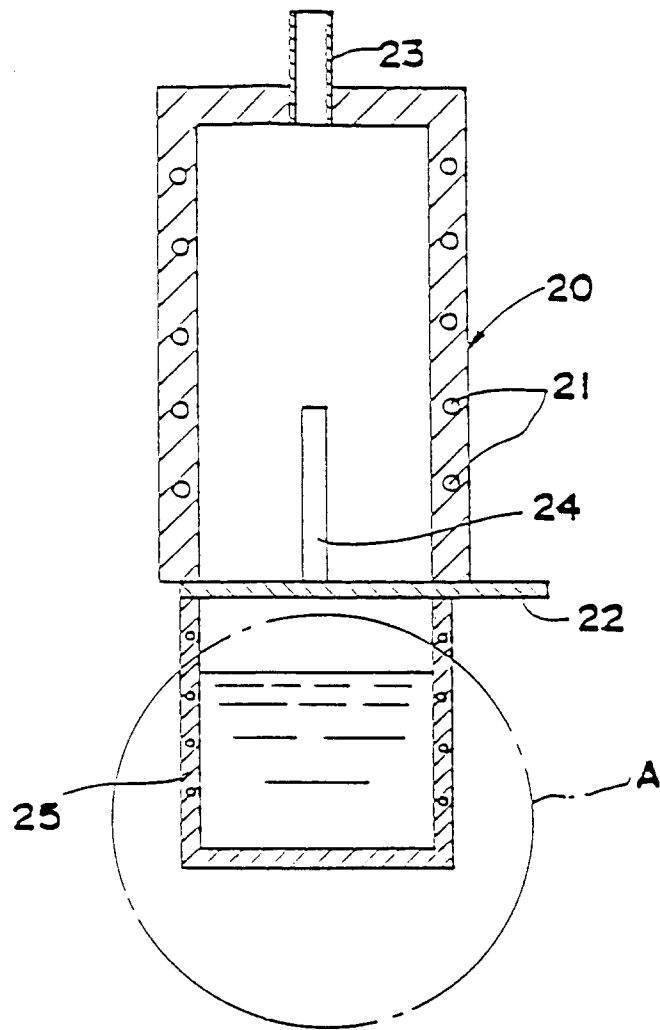

FIG. 5

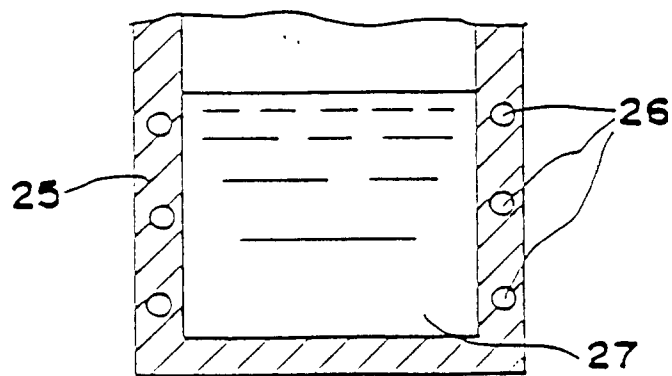

FIG. 6

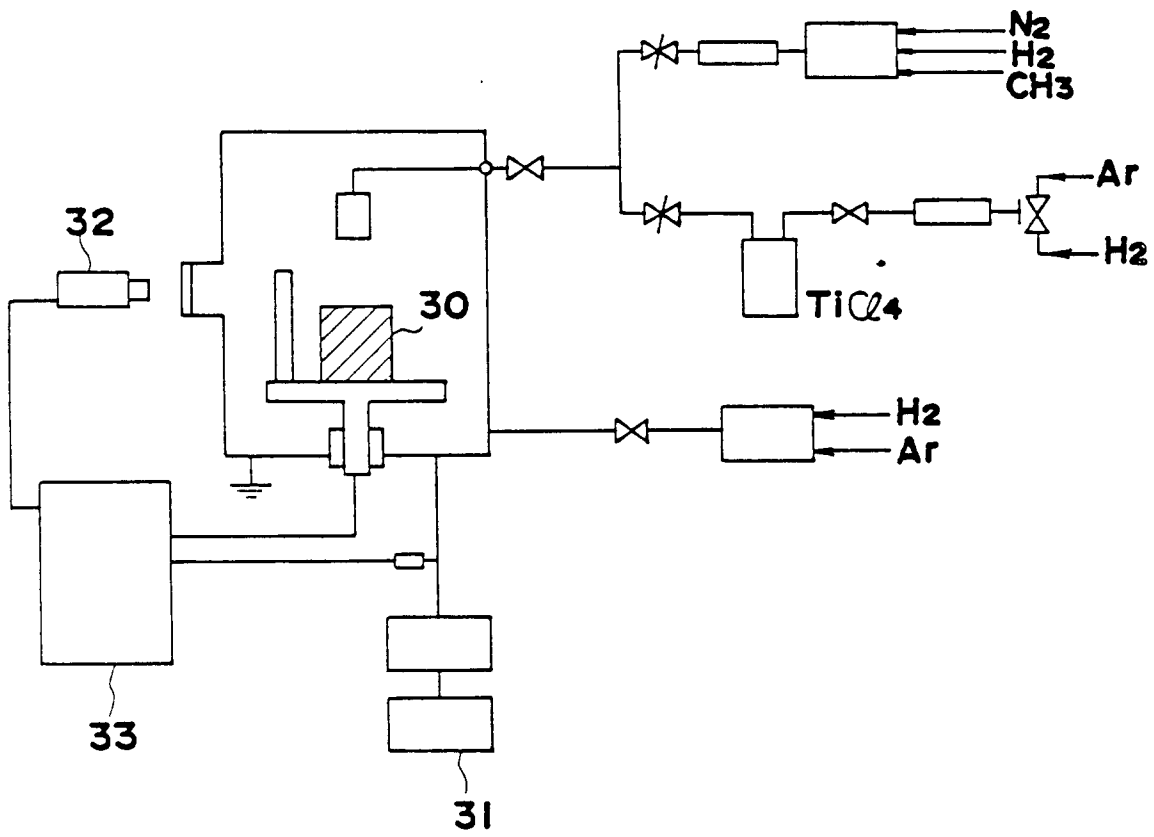
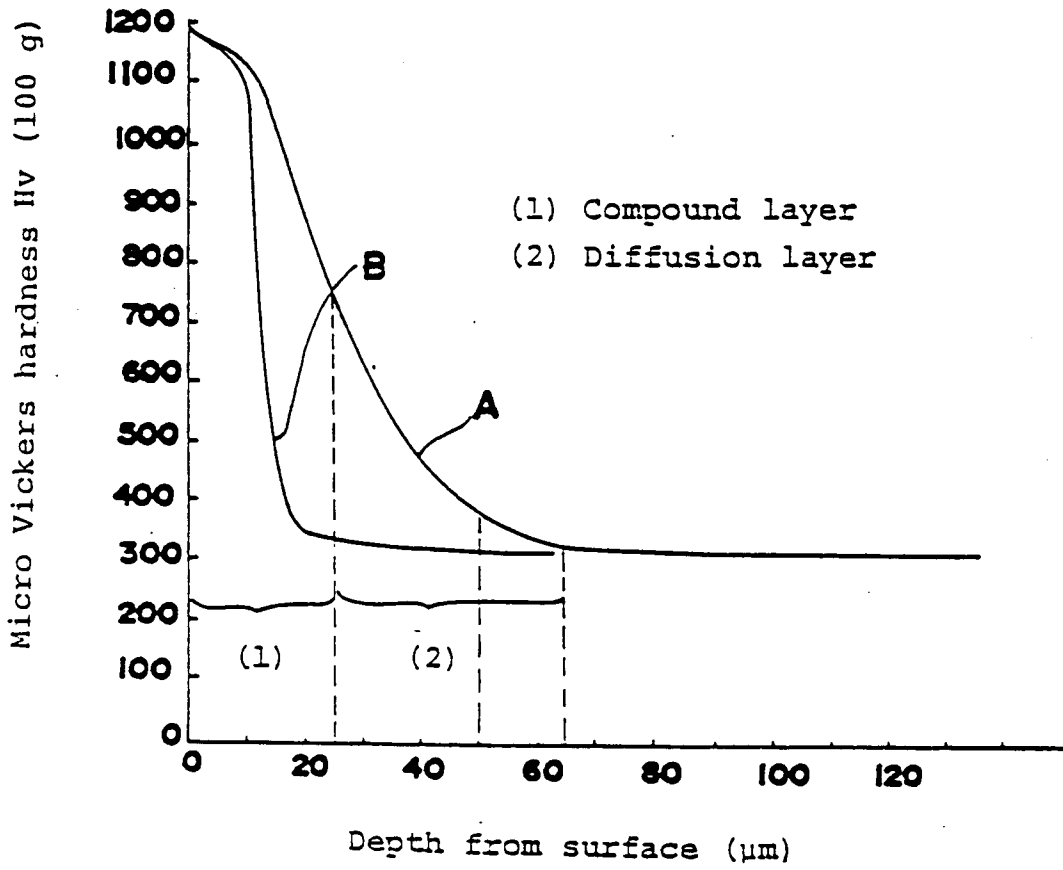

FIG. 7



F I G . 8