



US00D705757S

(12) **United States Design Patent**
Yashiro

(10) **Patent No.:** **US D705,757 S**

(45) **Date of Patent:** **** May 27, 2014**

- (54) **EARPHONE**
- (71) Applicant: **Sony Corporation**, Tokyo (JP)
- (72) Inventor: **Shogo Yashiro**, Tokyo (JP)
- (73) Assignee: **Sony Corporation**, Tokyo (JP)
- (**) Term: **14 Years**
- (21) Appl. No.: **29/454,943**
- (22) Filed: **May 15, 2013**

(30) **Foreign Application Priority Data**

Dec. 28, 2012 (JP) D2012-032190
 Dec. 28, 2012 (JP) D2012-032191
 Dec. 28, 2012 (JP) D2012-032192

(51) **LOC (10) Cl.** **14-01**

(52) **U.S. Cl.**
 CPC **H04R 1/10** (2013.01)
 USPC **D14/223**

(58) **Field of Classification Search**

CPC H04R 1/10
 USPC D14/205, 223, 188, 192; 181/129, 130,
 181/135; 379/430, 431; 381/370, 375, 380,
 381/381; 455/90.3, 575.2

See application file for complete search history.

(56) **References Cited**

U.S. PATENT DOCUMENTS

D177,346 S * 4/1956 Norris D14/192
 D304,944 S * 12/1989 Behringer D14/188
 D321,881 S * 11/1991 Hopewell D14/192
 D350,961 S * 9/1994 Nakamura D14/205
 D464,638 S * 10/2002 Huang D14/205

(Continued)

FOREIGN PATENT DOCUMENTS

JP D1423110 S 9/2011

Primary Examiner — Paula Greene
(74) Attorney, Agent, or Firm — Rader, Fishman & Grauer
 PLLC

(57) **CLAIM**

The ornamental design for an earphone, as shown and described.

DESCRIPTION

FIG. 1 is a front, top, right perspective view of a first embodiment of an earphone showing my new design; FIG. 2 is a rear, top, left perspective view thereof; FIG. 3 is a front elevational view thereof; FIG. 4 is a rear elevational view thereof; FIG. 5 is a left side elevational view thereof; FIG. 6 is a right side elevational view thereof; FIG. 7 is a top plan view thereof; and FIG. 8 is a bottom plan view thereof. FIG. 9 is a front, top, right perspective view of a second embodiment of an earphone showing my new design; FIG. 10 is a rear, top, left perspective view thereof; FIG. 11 is a front elevational view thereof; FIG. 12 is a rear elevational view thereof; FIG. 13 is a left side elevational view thereof; FIG. 14 is a right side elevational view thereof; FIG. 15 is a top plan view thereof; and FIG. 16 is a bottom plan view thereof. FIG. 17 is a front, top, right perspective view of a third embodiment of an earphone showing my new design; FIG. 18 is a rear, top, left perspective view thereof; FIG. 19 is a front elevational view thereof; FIG. 20 is a rear elevational view thereof; FIG. 21 is a left side elevational view thereof; FIG. 22 is a right side elevational view thereof; FIG. 23 is a top plan view thereof; and FIG. 24 is a bottom plan view thereof. The portions indicated in broken lines are for illustrative purposes only and form no part of the claimed design. Dot-dash broken lines define the boundaries of, but are not included in, the claimed design.

1 Claim, 24 Drawing Sheets

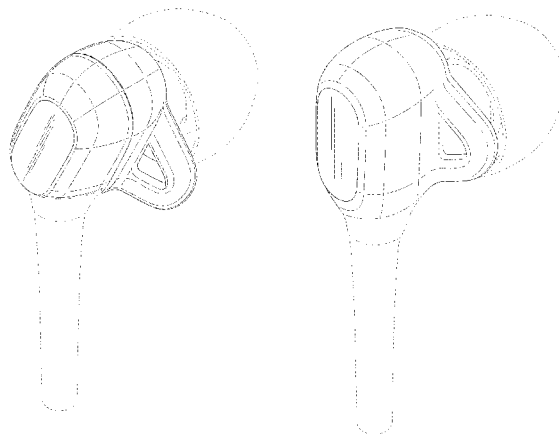

(56)

References Cited

U.S. PATENT DOCUMENTS

D469,755 S *	2/2003	Hlas et al.	D14/223	D598,431 S	8/2009	Densho	
D478,573 S *	8/2003	Wrisley et al.	D14/223	D601,548 S	10/2009	Morisawa	
D494,575 S *	8/2004	Wikel et al.	D14/240	D607,880 S	1/2010	Chung et al.	
D501,843 S *	2/2005	Oas	D14/188	D621,817 S *	8/2010	Brickstad	D14/223
D529,901 S	10/2006	Ohta		D634,736 S *	3/2011	Wikel et al.	D14/223
D543,972 S *	6/2007	Taylor	D14/223	D635,558 S *	4/2011	Zheng	D14/223
D559,837 S *	1/2008	Nakano	D14/223	D652,817 S *	1/2012	Lee et al.	D14/205
D566,099 S *	4/2008	Komiyama	D14/206	D669,450 S *	10/2012	Katsumata	D14/205
D587,248 S	2/2009	Densho		D681,602 S *	5/2013	Koch et al.	D14/205
D597,534 S *	8/2009	Christopher	D14/223	D683,332 S *	5/2013	Lee et al.	D14/223
				D685,770 S *	7/2013	Lee et al.	D14/223
				2012/0114160 A1 *	5/2012	Lin	381/380

* cited by examiner

FIG.1

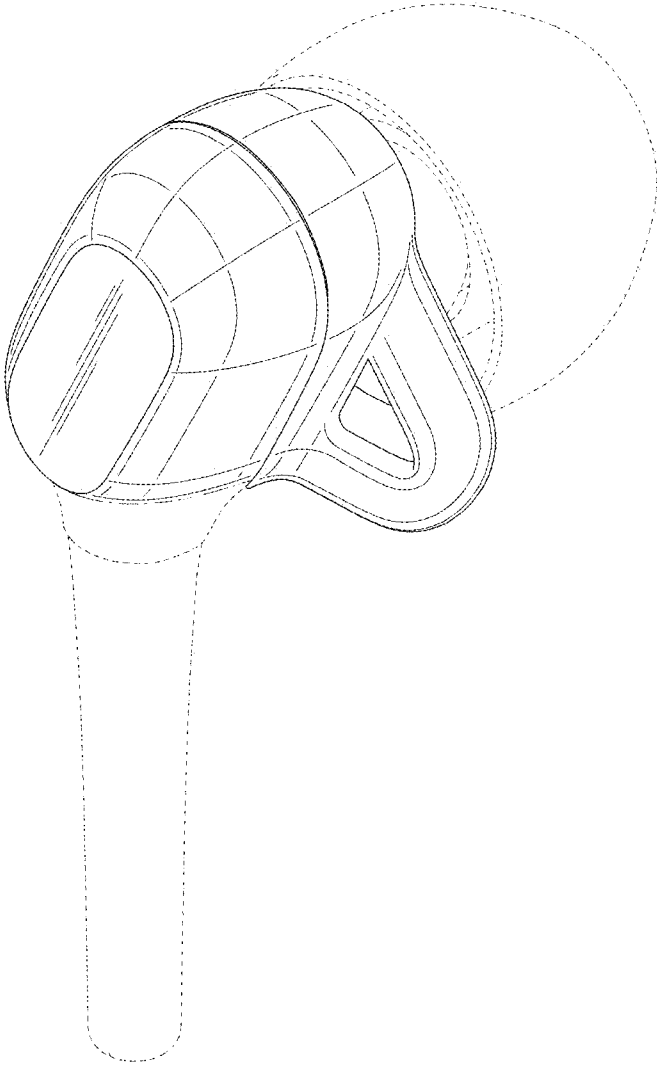

FIG.2

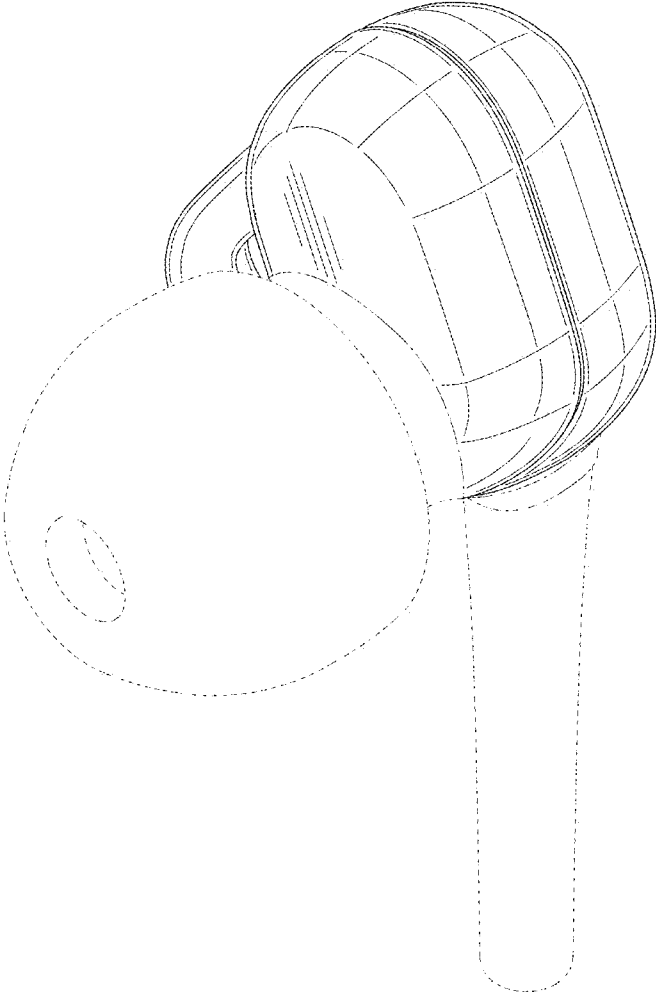

FIG.3

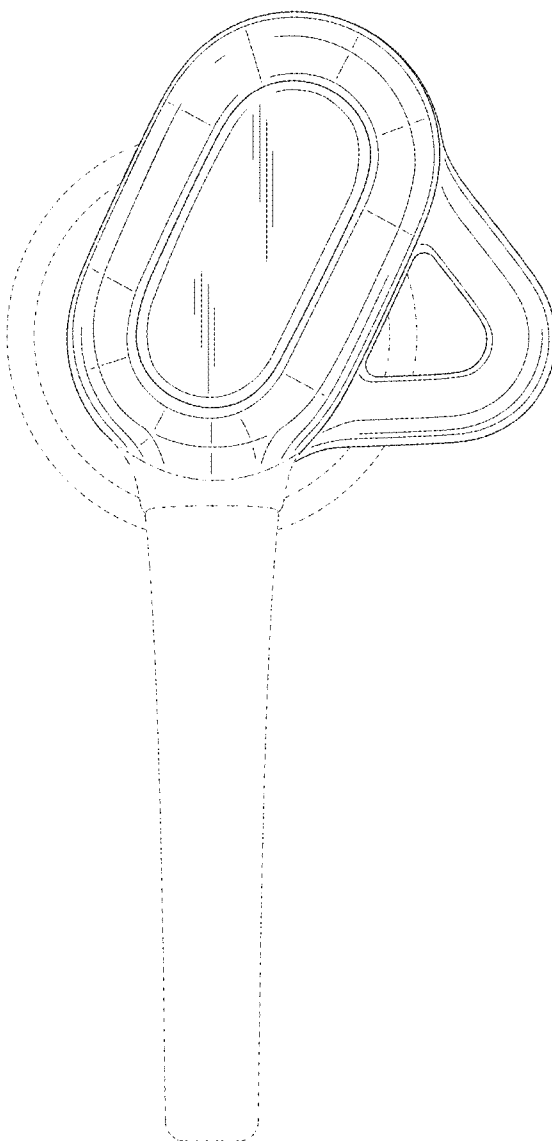

FIG.4

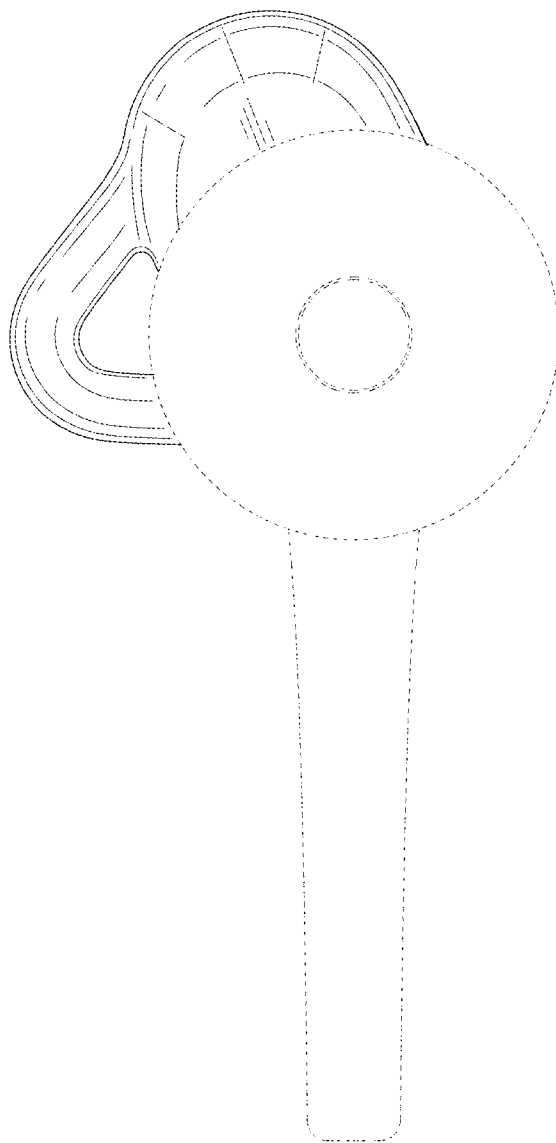

FIG.5

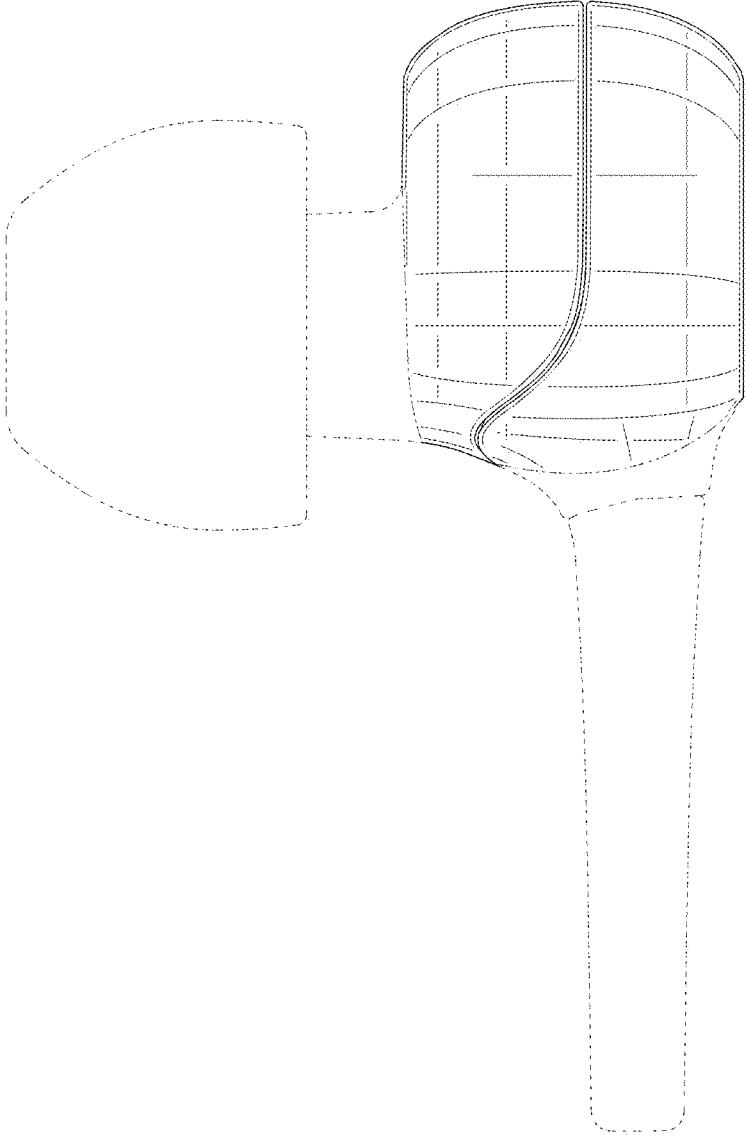

FIG.6

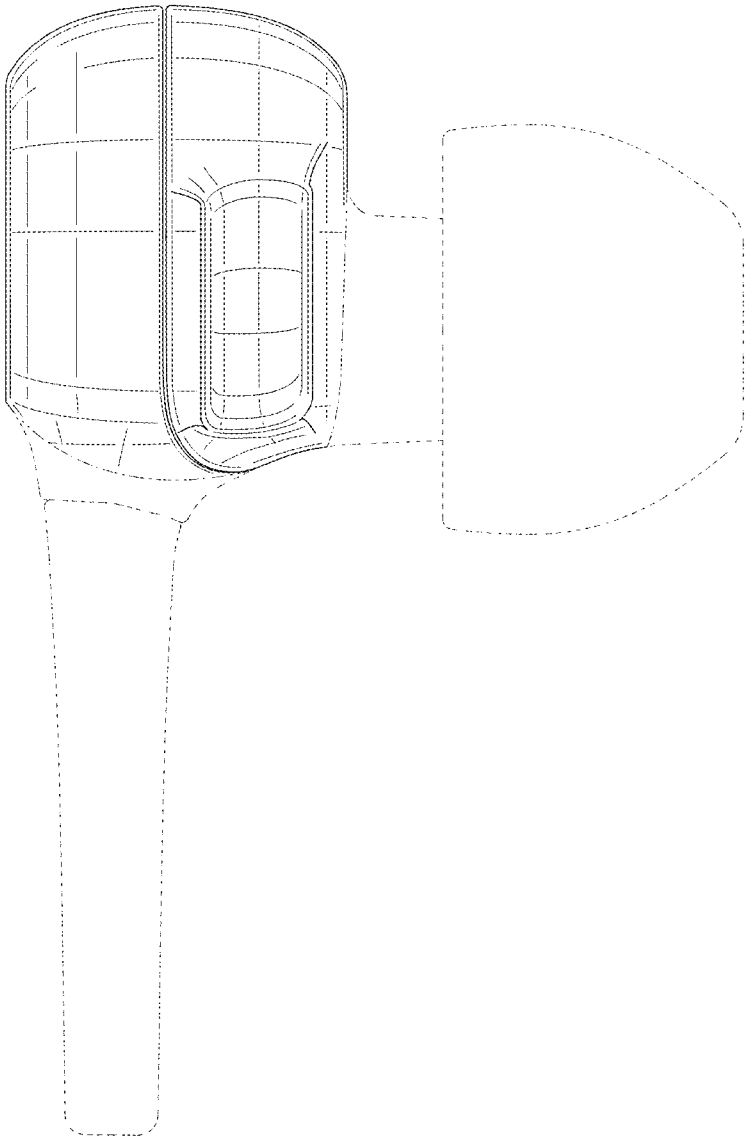

FIG. 7

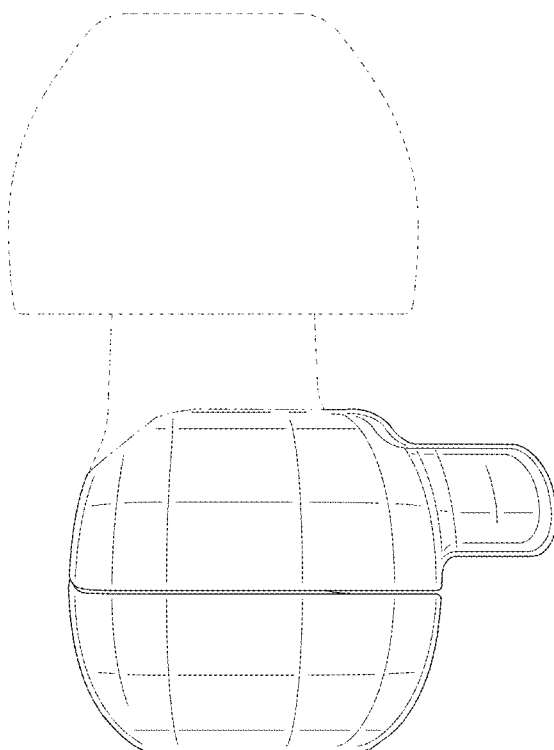

FIG.8

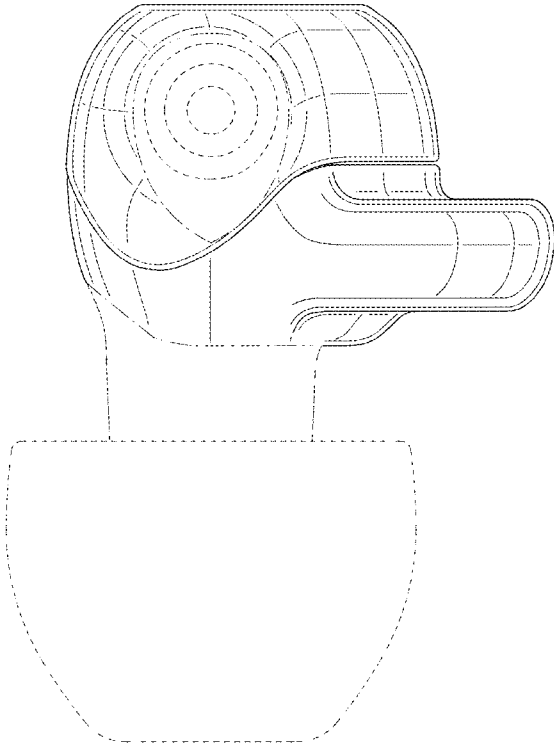

FIG.9

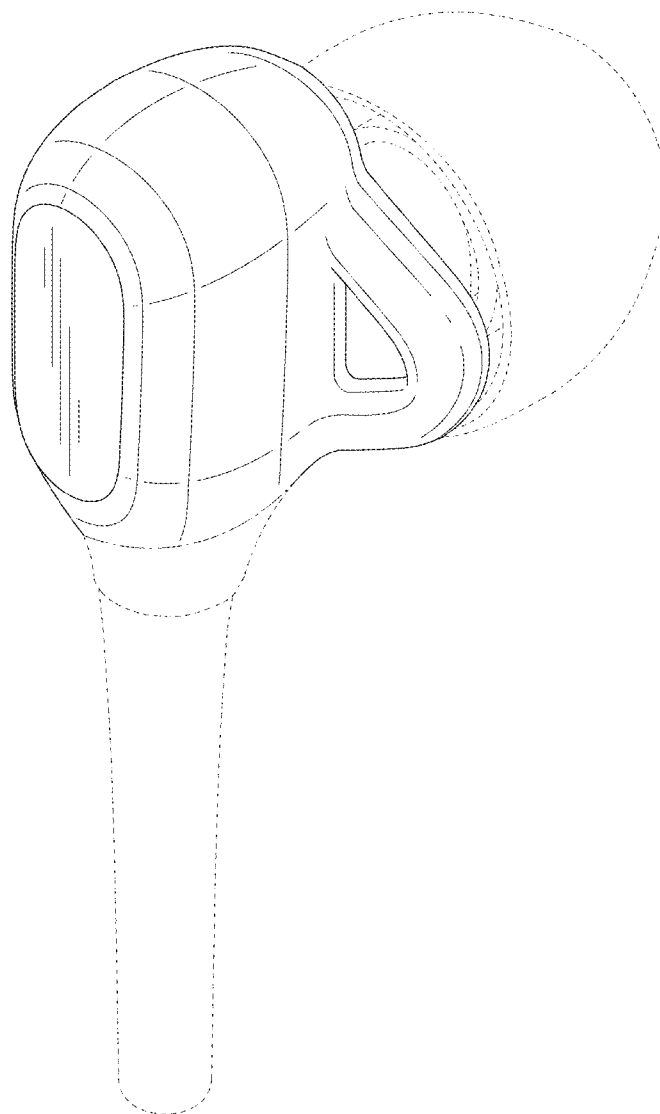

FIG.10

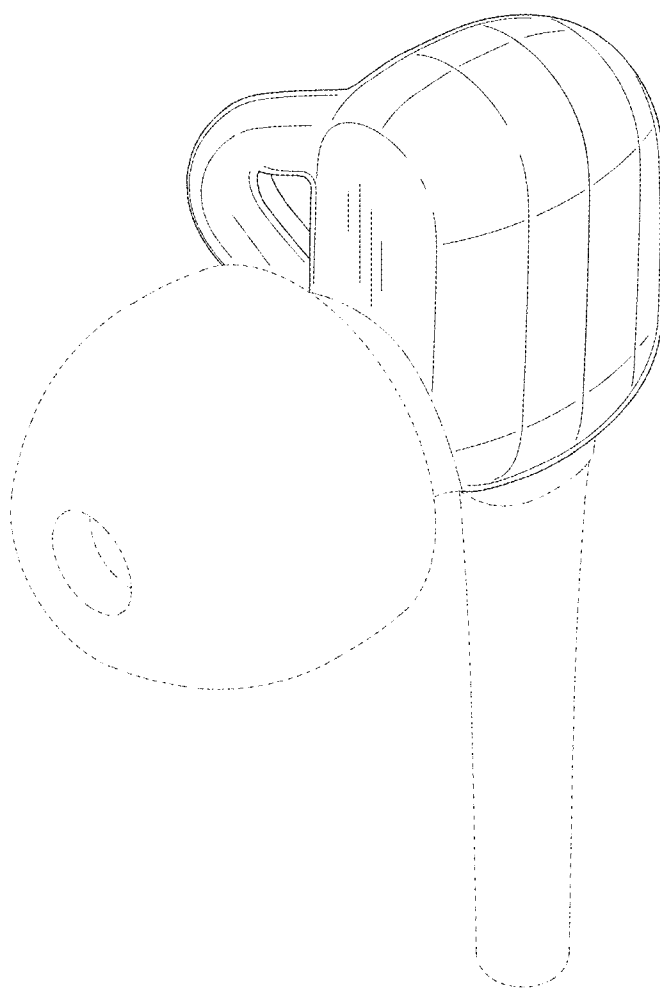

FIG. 11

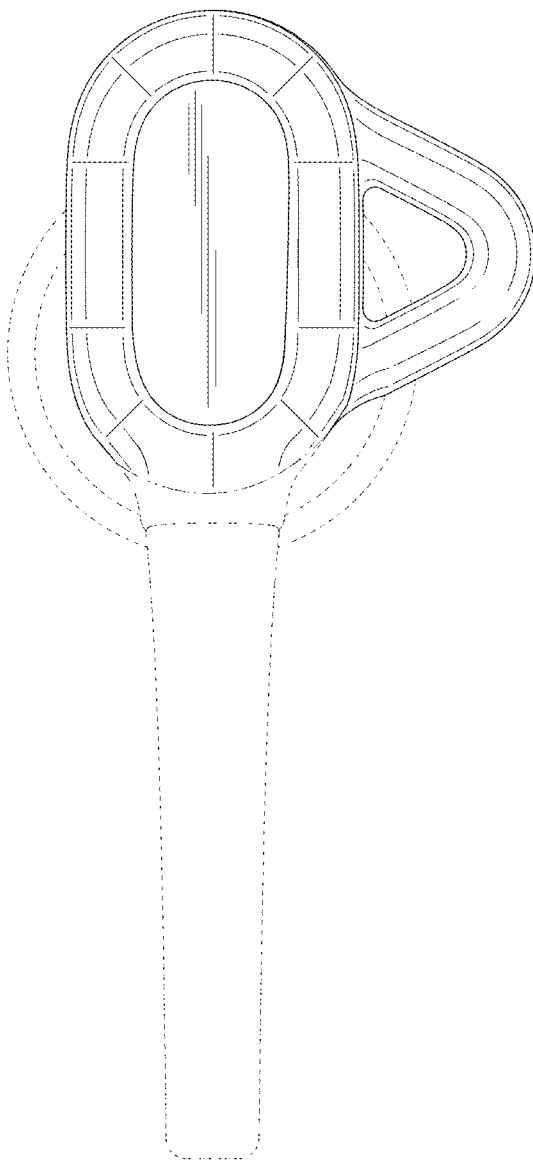

FIG.12

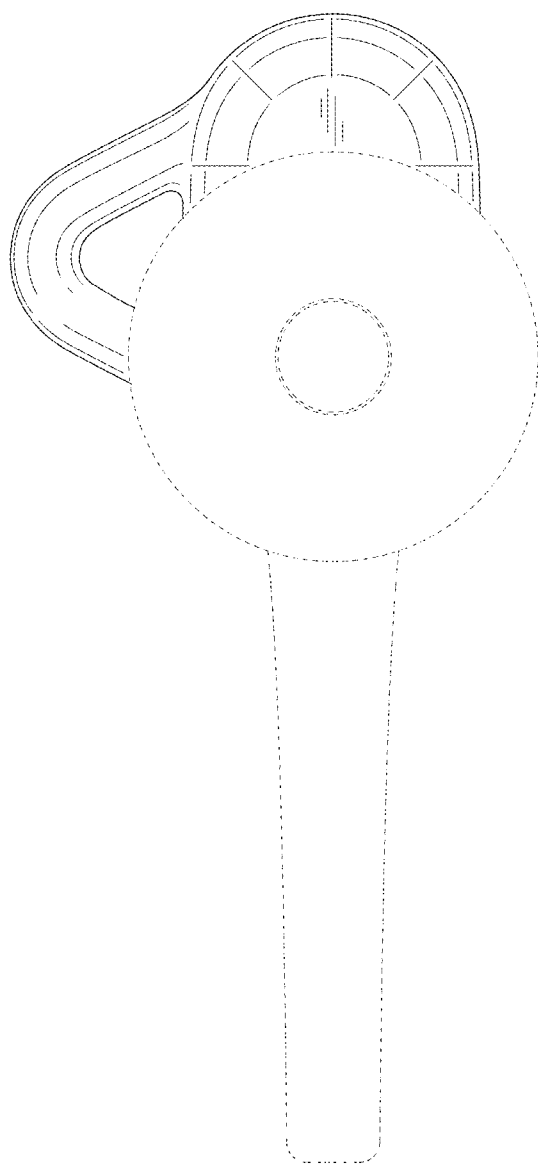

FIG.13

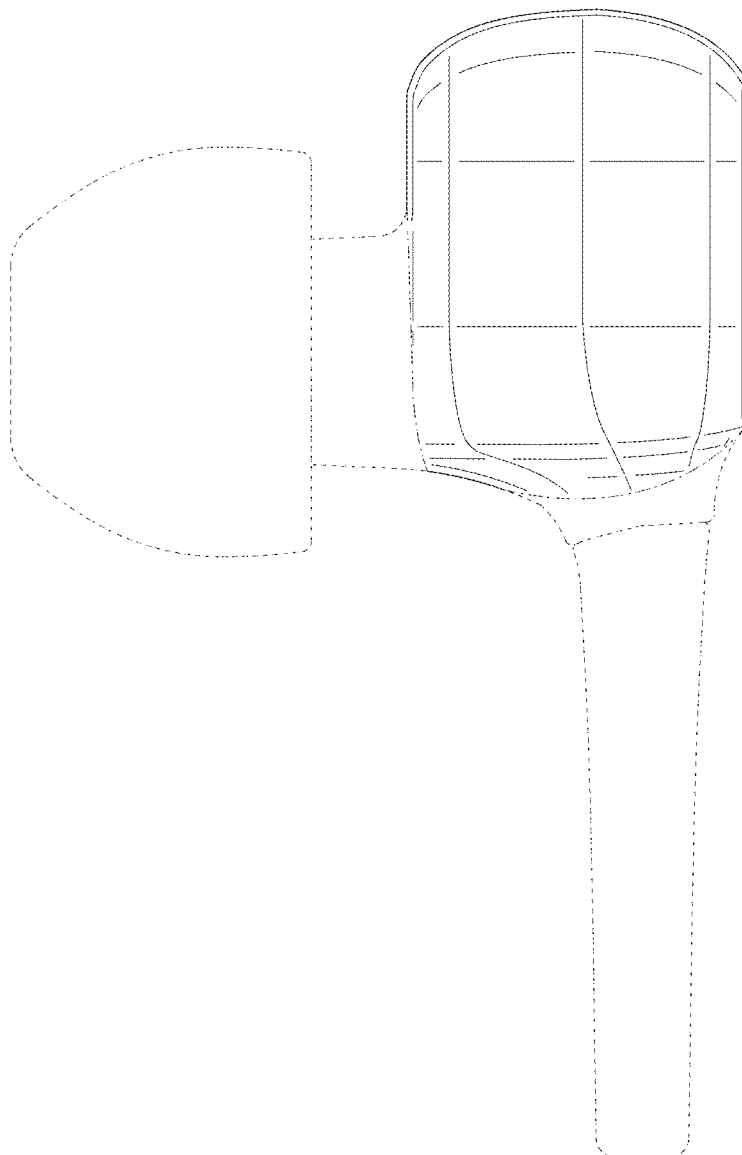

FIG.14

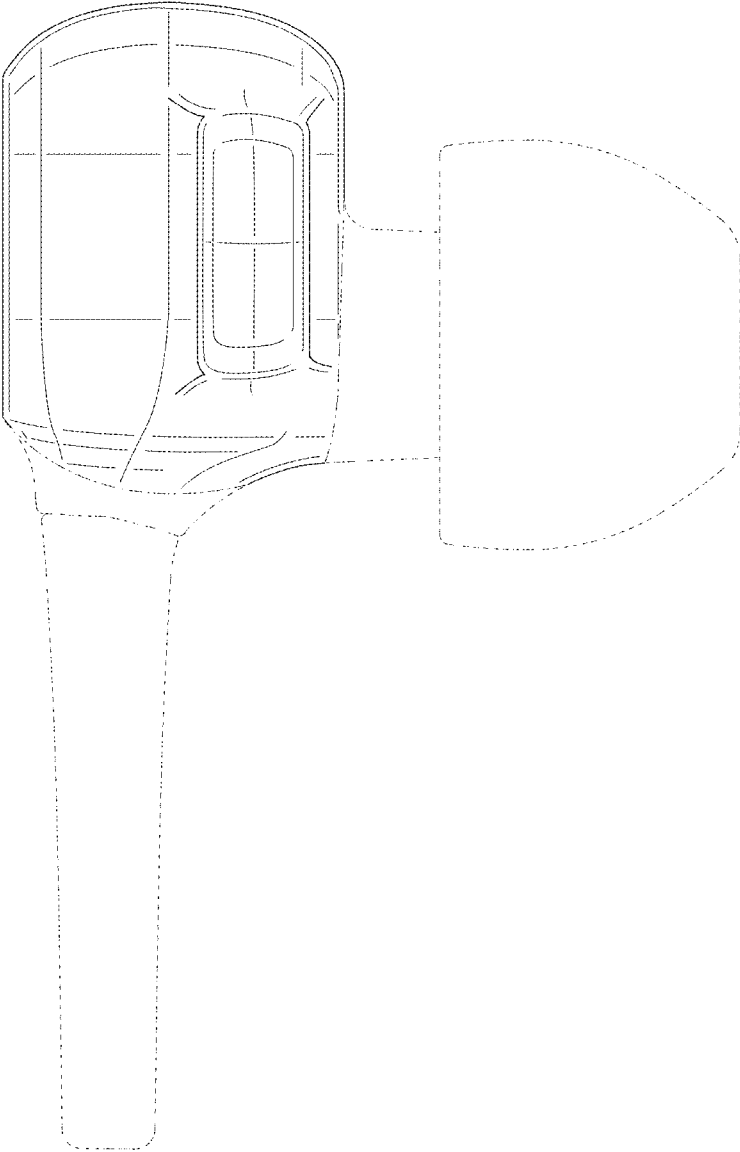

FIG.15

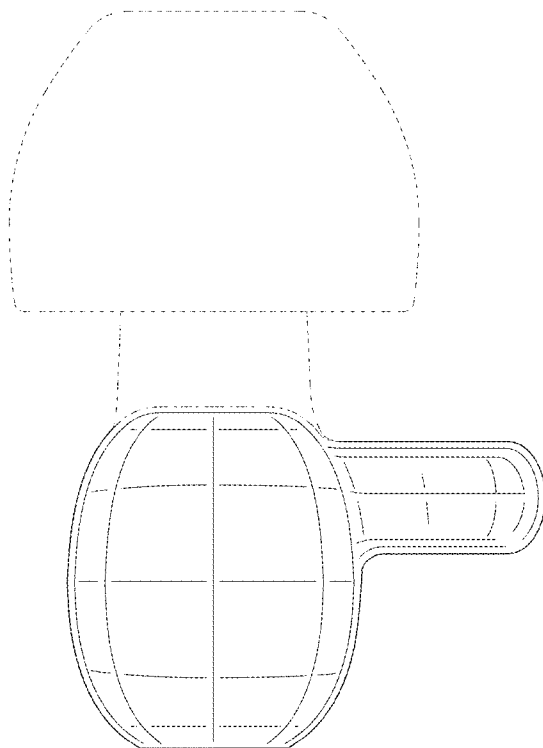

FIG.16

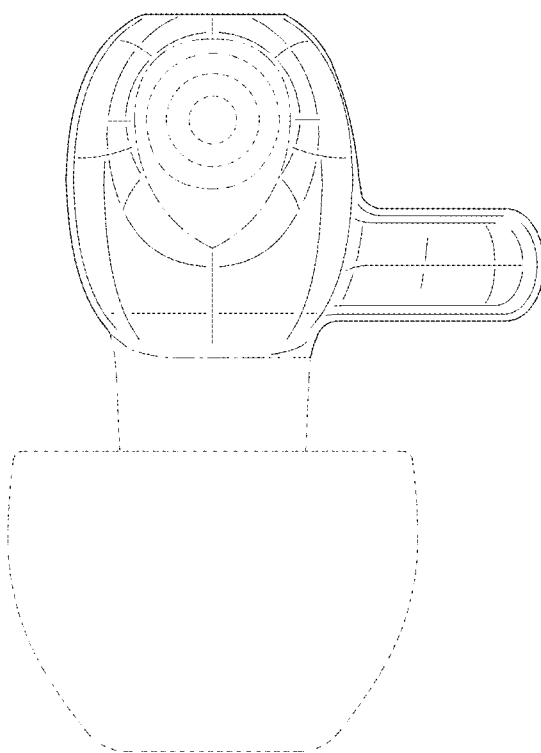

FIG.17

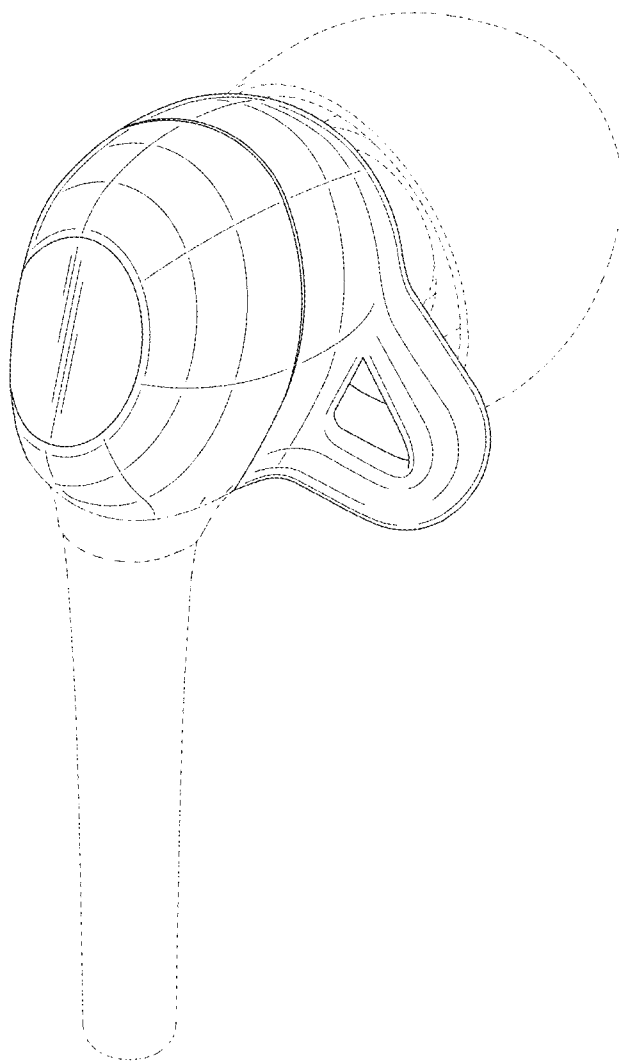

FIG.18

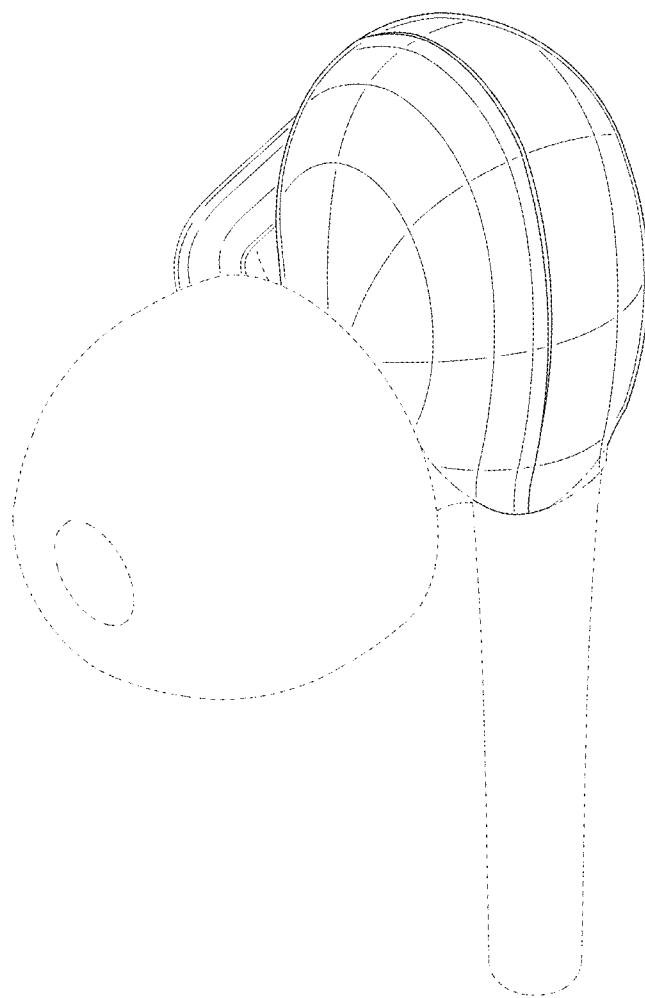

FIG.19

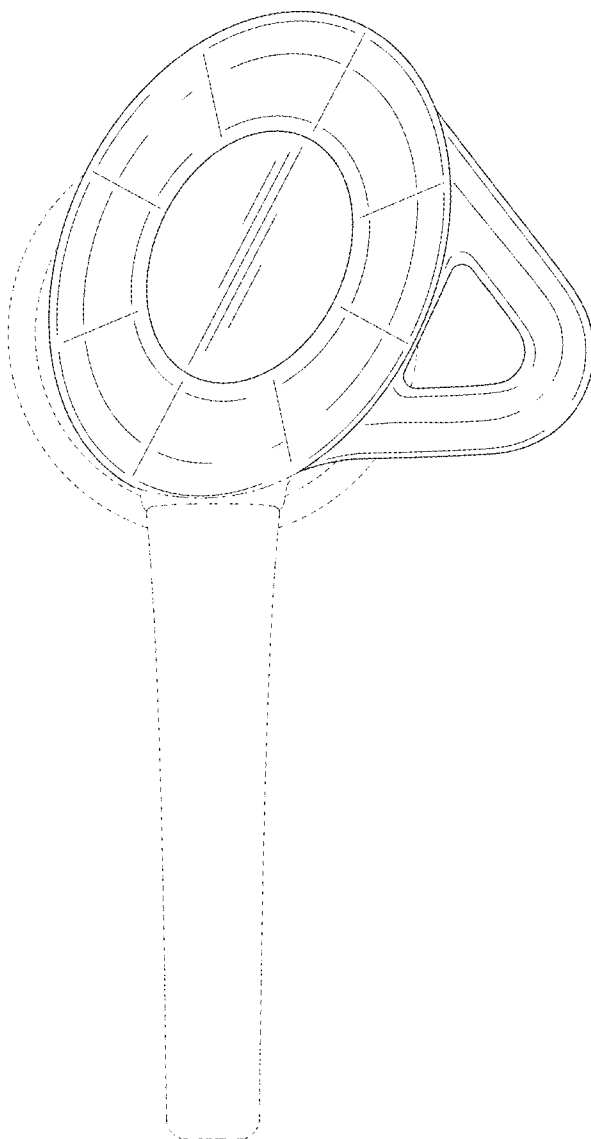

FIG.20

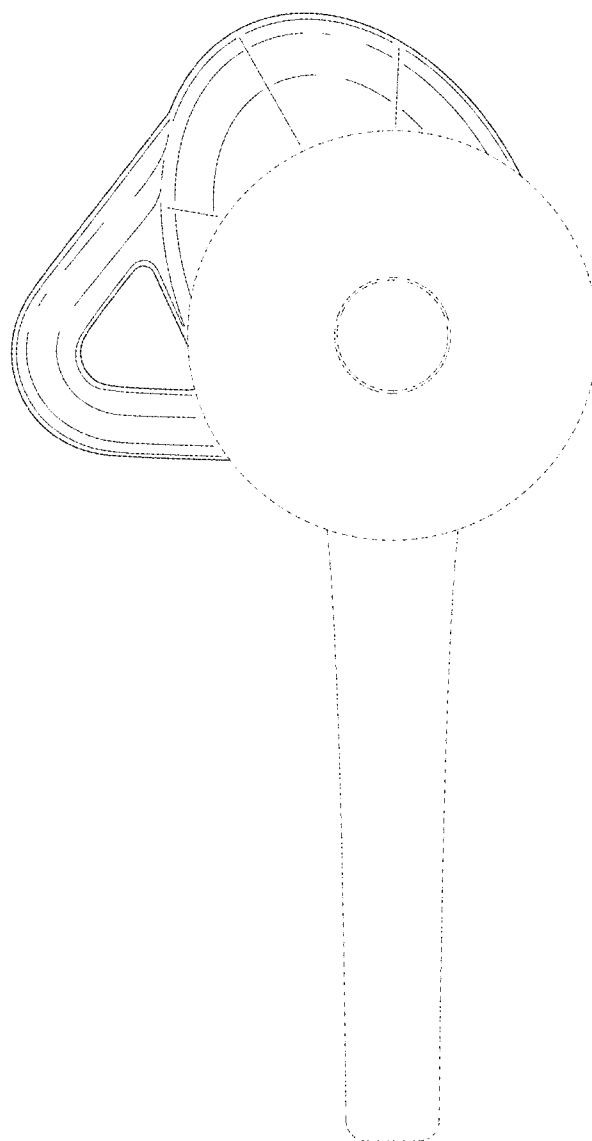

FIG.21

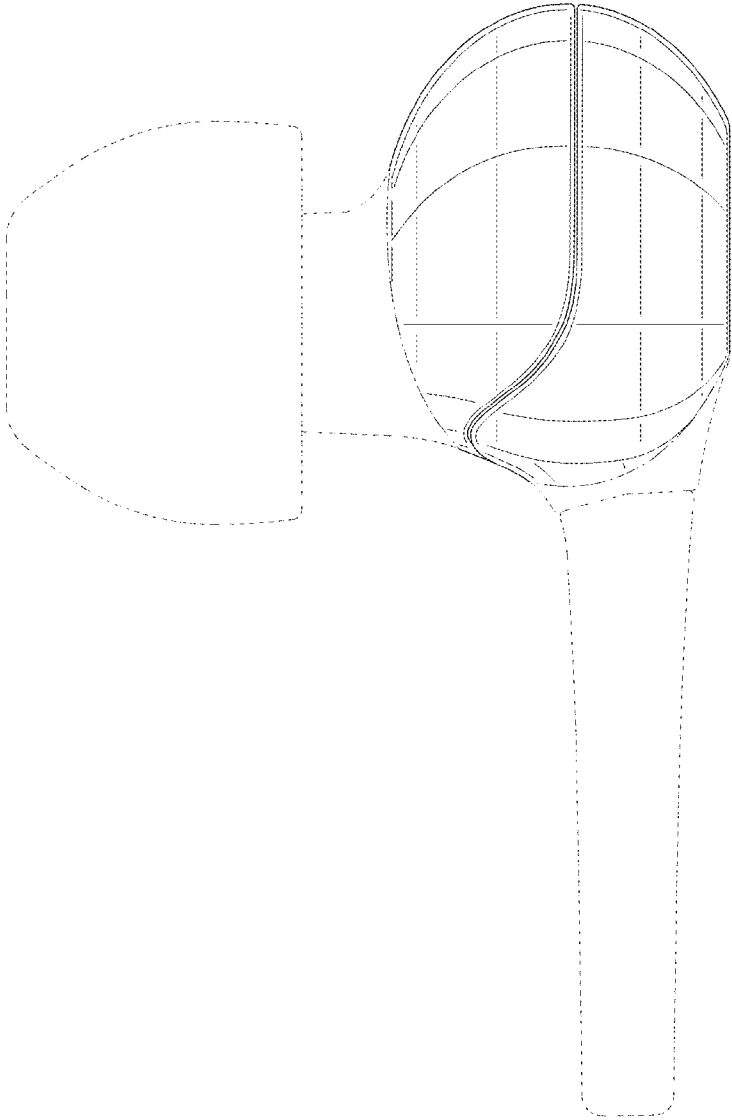

FIG.22

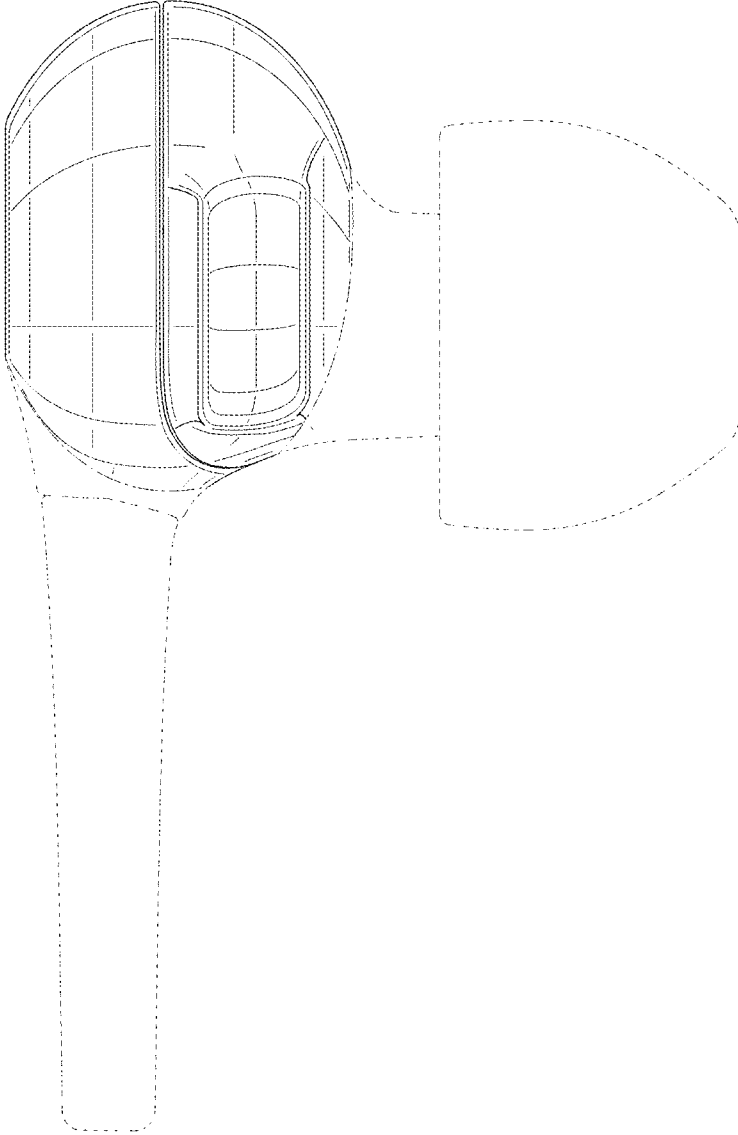

FIG.23

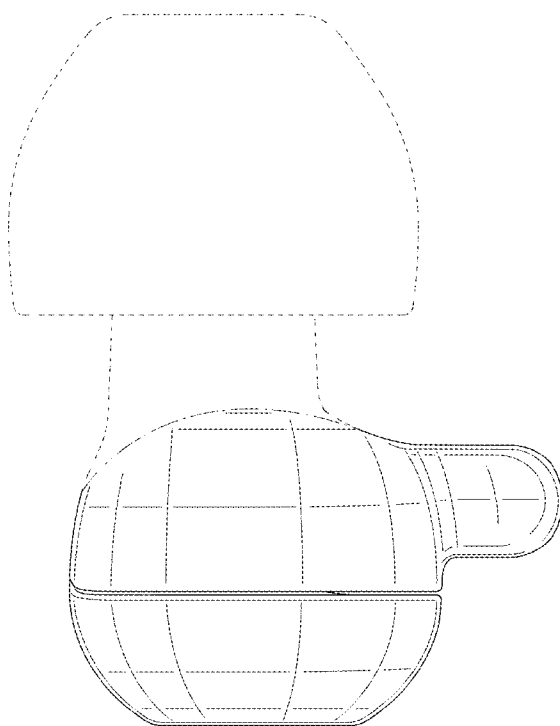

FIG.24

