

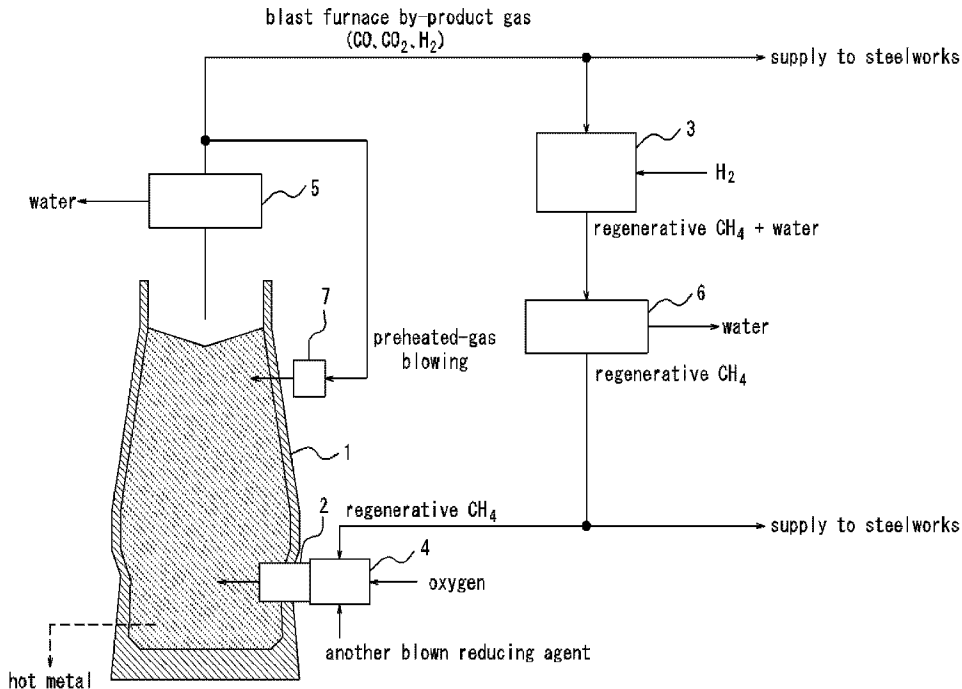

(86) **Date de dépôt PCT/PCT Filing Date:** 2020/11/11
 (87) **Date publication PCT/PCT Publication Date:** 2021/06/03
 (45) **Date de délivrance/Issue Date:** 2024/04/30
 (85) **Entrée phase nationale/National Entry:** 2022/04/13
 (86) **N° demande PCT/PCT Application No.:** JP 2020/042144
 (87) **N° publication PCT/PCT Publication No.:** 2021/106578
 (30) **Priorité/Priority:** 2019/11/25 (JP2019-212514)

(51) **Cl.Int./Int.Cl. C21B 5/00** (2006.01),
C21B 7/00 (2006.01)
 (72) **Inventeurs/Inventors:**
TAKAHASHI, KOICHI, JP;
NOUCHI, TAIHEI, JP;
OZAWA, SUMITO, JP;
KAWASHIRI, YUKI, JP;
MORITA, YUYA, JP
 (73) **Propriétaire/Owner:**
JFE STEEL CORPORATION, JP
 (74) **Agent:** ROBIC AGENCE PI S.E.C./ROBIC IP AGENCY
LP

(54) **Titre : PROCÉDE D'EXPLOITATION DE HAUT-FOURNEAU ET EQUIPEMENT AUXILIAIRE DE HAUT-FOURNEAU**
 (54) **Title: METHOD OF OPERATING BLAST FURNACE AND BLAST FURNACE ANCILLARY FACILITY**



(57) **Abrégé/Abstract:**

Provided is a method of operating a blast furnace, having generating a regenerative methane gas from a by-product gas discharged from the blast furnace, and blowing a blast gas and a reducing agent into the blast furnace from a tuyere of the blast furnace in which the blast gas is oxygen gas and the regenerative methane gas is used as at least part of the reducing agent.

ABSTRACT

5 Provided is a method of operating a blast furnace, having generating a regenerative methane gas from a by-product gas discharged from the blast furnace, and blowing a blast gas and a reducing agent into the blast furnace from a tuyere of the blast furnace in which the blast gas is oxygen gas and the regenerative methane gas is used as at least part of the reducing agent.

DESCRIPTION

TITLE

METHOD OF OPERATING BLAST FURNACE AND BLAST FURNACE
ANCILLARY FACILITY

5

TECHNICAL FIELD

[0001] The present disclosure relates to a method of operating a blast furnace and a blast furnace ancillary facility.

10

BACKGROUND

[0002] In recent years, there has been a strong need to reduce carbon dioxide (CO₂) emissions against the backdrop of global environmental issues. Therefore, operation with a low reducing agent rate (low RAR) is required in operating a blast furnace installed in a steelworks.

15

[0003] In a typical blast furnace, hot blast (air heated to about 1200 °C) is blown into the blast furnace as a blast gas from a tuyere. As a result, oxygen in the hot blast reacts with coke or pulverized coal as a reducing agent to produce carbon monoxide (CO) and hydrogen (H₂) gases. These carbon monoxide and hydrogen gases reduce iron ore charged into the blast furnace. In addition, carbon dioxide is produced during the reduction reaction of the iron ore.

20

The blast gas is a gas that is blown into the blast furnace from the tuyere. The blast gas also plays a role in gasifying the pulverized coal and coke in the blast furnace.

25

[0004] As a technique to reduce carbon dioxide emissions in blast furnace operations, a technique has been proposed to reform the carbon monoxide and carbon dioxide contained in the by-product gas emitted from the blast furnace, etc., to produce hydrocarbons such as methane and ethanol, and to introduce the produced hydrocarbons back into the blast furnace as a reducing agent.

30

[0005] For example, JP2011-225969A (PTL 1) describes:

“a method of operating a blast furnace comprising a step (A) of separating and recovering CO₂ and/or CO from a mixed gas containing CO₂ and/or CO, a step (B) of adding hydrogen to the CO₂ and/or CO separated and recovered in the step (A) and converting the CO₂ and/or CO into CH₄, a step (C) of separating and removing H₂O from the gas that has undergone the step

35

(B), and a step (D) of blowing the gas that has undergone the step (C) into the blast furnace”.

[0006] JP2014-005510A (PTL 2) describes:

5 “a method of operating a blast furnace comprising separating CO₂ from an exhaust gas of a combustion furnace that uses a blast furnace by-product gas as the whole or a part of fuel, reforming the separated CO₂ into methane to obtain a reducing gas, and blowing the reducing gas into the blast furnace”.

CITATION LIST

10 Patent Literature

[0007] PTL 1: JP 2011-225969A

PTL 2: JP 2014-005510A

SUMMARY

15 (Technical Problem)

[0008] However, with the techniques of PTLs 1 and 2, when the amount of methane blown into the blast furnace as the reducing agent exceeds a certain level, it may cause operational problems such as insufficient heating of the bottom of the blast furnace, pressure drop increase, and tapping failure.

20 Therefore, there is a need to develop a method of operating a blast furnace that can further reduce carbon dioxide emissions from the blast furnace under stable operation.

[0009] In view of the current situation described above, it could be helpful to provide a method of operating a blast furnace that can further reduce carbon dioxide emissions from the blast furnace under stable operation.

It could also be helpful to provide a blast furnace ancillary facility for use in the method of operating a blast furnace described above.

(Solution to Problem)

[0010] We conducted intensive studies to achieve the objects stated above.

30 First, we examined the cause of operational problems occurring when the amount of methane blown into the blast furnace as a reducing agent exceeds a certain level in the techniques of PTLs 1 and 2.

As a result, we have made the following discoveries.

35 When the amount of methane blown into the blast furnace as a reducing agent exceeds a certain level, the temperature of flame (hereinafter referred to as tuyere-outlet temperature) generated by the combustion of the blown

reducing agent and coke in the combustion area (raceway) near the outlet of the tuyere decreases significantly. The decrease in the tuyere-outlet temperature becomes the cause of the operational problems such as insufficient heating of the bottom of the blast furnace, pressure drop increase, and tapping failure.

[0011] In detail, when pulverized coal is blown into the blast furnace from the tuyere as a reducing agent, because the main component of the pulverized coal is carbon, the following reaction occurs in the raceway:

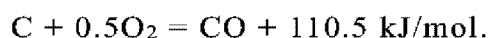

On the other hand, when methane is blown as a reducing agent into the blast furnace from the tuyere, the following reaction occurs in the raceway:

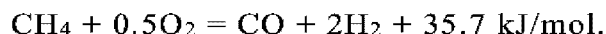

The amount of heat generated during the reaction, when converted to one mole of the total amount of CO and H₂, is 11.9 kJ/mol.

For stable operation of the blast furnace, it is necessary to control the tuyere-outlet temperature in the range of 2000 °C to 2400 °C. However, if most of the reducing agent blown into the blast furnace is changed to methane gas from pulverized coal, the tuyere-outlet temperature will decrease due to the difference in reaction heat described above. As a result, the tuyere-outlet temperature cannot be controlled within the above range, and various operational problems occur.

[0012] Based on the above discoveries, we made further investigations.

As a result, we have made following discoveries. Using oxygen gas instead of hot blast (air heated to about 1200 °C) as the blast gas effectively prevented the decrease in the tuyere-outlet temperature even when a large amount of methane is used as the reducing agent to be blown into the blast furnace. Further, by regenerating such methane from a by-product gas discharged from the blast furnace and blowing the regenerated methane (regenerative methane gas) back into the blast furnace as a reducing agent, stable blast furnace operation can be achieved while further reducing carbon dioxide emissions from the blast furnace.

In addition, the amount of nitrogen contained in the by-product gas discharged from the blast furnace is greatly reduced by using oxygen gas with a particularly high oxygen concentration as the blast gas. As a result, the process of separating carbon monoxide and carbon dioxide from the by-product gas is no longer necessary, which is extremely advantageous in terms of facility

compactness.

[0013] We believe that the reason why the tuyere-outlet temperature can be controlled in the range of 2000 °C to 2400 °C by using oxygen gas as the blast gas even when a large amount of methane is used as the reducing agent blown into the blast furnace is as follows.

In detail, when hot blast (air heated to about 1200 °C) is used as the blast gas, the combustion gas contains nitrogen of about 50 % by volume, which does not contribute to the combustion reaction, and thus the flame temperature in the raceway is hardly to be high. Therefore, when most of the reducing agent blown into the blast furnace is changed to methane gas from pulverized coal, the difference between the reaction heat in the pulverized coal-oxygen reaction and the reaction heat in the methane gas-oxygen reaction described above will cause the tuyere-outlet temperature to drop, and eventually the tuyere-outlet temperature will fall below 2000 °C, which is the lower limit of the appropriate temperature.

On the other hand, the use of oxygen gas as the blast gas can suppress the mixing of nitrogen gas, which does not contribute to the combustion reaction, so that the tuyere-outlet temperature can be raised to a sufficient temperature. In detail, the flame temperature in the raceway can be made higher than when hot blast is used, so that even when a large amount of methane is blown in as a reducing agent from the tuyere, the tuyere-outlet temperature can be controlled in the range of 2000 °C to 2400 °C, which is the appropriate range.

The present disclosure is based on these discoveries and further studies.

[0014] Primary features of the present disclosure are as follows.

1. A method of operating a blast furnace, comprising
generating a regenerative methane gas from a by-product gas discharged from the blast furnace, and

blowing a blast gas and a reducing agent into the blast furnace from a tuyere,

wherein the blast gas is oxygen gas and the regenerative methane gas is used as at least part of the reducing agent.

[0015] 2. The method of operating a blast furnace according to 1., wherein a consumption rate of circulating carbon atoms in the reducing agent is 60 kg/t or more,

wherein the consumption rate of circulating carbon atoms is a carbon equivalent mass of the regenerative methane gas that is blown into the blast furnace as the reducing agent for producing 1 t of hot metal, and is obtained by the following equation:

$$[\text{Consumption rate of circulating carbon atoms (kg/t)}] = [\text{Mass of methane in regenerative methane gas blown into blast furnace as reducing agent (kg)}] \times (12/16) \div [\text{Production amount of hot metal (t)}].$$

[0016] 3. The method of operating a blast furnace according to 1. or 2., wherein the oxygen gas has an oxygen concentration of 80 % or more by volume.

[0017] 4. The method of operating a blast furnace according to any one of 1. to 3., wherein the regenerative methane gas is generated from a part of the by-product gas and a surplus of the by-product gas is supplied to a steelworks.

[0018] 5. The method of operating a blast furnace according to any one of 1. to 4., wherein a surplus of the regenerative methane gas is supplied to the steelworks.

[0019] 6. A blast furnace ancillary facility used in the method of operating a blast furnace according to any one of 1. to 5., comprising

a methane gas generation device that generates the regenerative methane gas from the by-product gas, and

a gas blowing device having a methane gas supply section that introduces the regenerative methane gas into the tuyere of the blast furnace and an oxygen gas supply section that introduces the oxygen gas into the tuyere of the blast furnace.

[0019a] Various other aspects of the invention are described hereinafter with reference to the following preferred embodiments **[1]** to **[5]**.

- [1]** A method of operating a blast furnace, comprising
- generating a regenerative methane gas from a by-product gas discharged from the blast furnace, and
- blowing a blast gas and a reducing agent into the blast furnace from a tuyere,
- wherein the blast gas is an oxygen gas and the regenerative methane gas is used as at least part of the reducing agent,
- wherein a consumption rate of circulating carbon atoms in the reducing agent is 55 kg/t or more, the consumption rate of circulating carbon atoms being a carbon equivalent mass of the regenerative methane gas that is blown into the blast furnace as the reducing agent for producing 1 t of hot metal,
- wherein the oxygen gas has an oxygen concentration of 80 % to 100 % by volume, and
- wherein the regenerative methane gas has a methane concentration of 80 % to 100 % by volume.
- [2]** The method of operating a blast furnace according to **[1]**, wherein a consumption rate of circulating carbon atoms in the reducing agent is 60 kg/t or more,
- wherein the consumption rate of circulating carbon atoms is obtained by the following equation:
- $$[\text{Consumption rate of circulating carbon atoms (kg/t)}] = [\text{Mass of methane in regenerative methane gas blown into blast furnace as reducing agent (kg)}] \times (12/16) \div [\text{Production amount of hot metal (t)}].$$

- [3]** The method of operating a blast furnace according to **[1]** or **[2]**, wherein the regenerative methane gas is generated from a part of the by-product gas and a surplus of the by-product gas is supplied to a steelworks.
- [4]** The method of operating a blast furnace according to any one of **[1]** to **[3]**, wherein a surplus of the regenerative methane gas is supplied to the steelworks.
- [5]** A blast furnace ancillary facility used in the method of operating a blast furnace according to any one of **[1]** to **[4]**, comprising
- a methane gas generation device that generates the regenerative methane gas from the by-product gas, and
- a gas blowing device having a methane gas supply section that introduces the regenerative methane gas into the tuyere of the blast furnace and an oxygen gas supply section that introduces the oxygen gas into the tuyere of the blast furnace.

(Advantageous Effect)

[0020] The present disclosure enables further reduction of carbon dioxide (CO₂) emissions from the blast furnace under stable operation. The use of the methane gas generated from the blast furnace by-product gas can also reduce the amount of coke and pulverized coal used, that is, the amount of coal as a finite fossil fuel used.

In addition, since the amount of nitrogen in the by-product gas discharged from the blast furnace is greatly reduced, the process of separating carbon monoxide and carbon dioxide from the by-product gas, or in other words, the huge pressure swing adsorption (PSA) separator or the like is not necessary, which is extremely advantageous in terms of making the facility more compact.

BRIEF DESCRIPTION OF THE DRAWINGS

[0021] In the accompanying drawings:

FIG. 1 schematically illustrates an example of a blast furnace and blast furnace ancillary facility used in the method of operating a blast furnace according to one of the disclosed embodiments;

FIGS. 2A and 2B each schematically illustrate an example of a gas blowing device used in the method of operating a blast furnace according to one of the disclosed embodiments;

FIG. 3 schematically illustrates an example of a blast furnace and blast furnace ancillary facility used in the method of operating a blast furnace according to one of the disclosed embodiments;

FIG. 4 schematically illustrates an example of a blast furnace and blast furnace ancillary facility used in the method of operating a blast furnace according to one of the disclosed embodiments;

FIG. 5 schematically illustrates a blast furnace and blast furnace ancillary facility used in a comparative example;

FIG. 6 schematically illustrates a blast furnace and blast furnace ancillary facility used in a comparative example;

FIG. 7 schematically illustrates a blast furnace and blast furnace ancillary facility used in a comparative example; and

FIG. 8 illustrates an example of the relationship between the consumption rate of circulating carbon atoms and the tuyere-outlet temperature for hot blast and oxygen gas blowing conditions.

DETAILED DESCRIPTION

[0022] This disclosure will be described below based on the following embodiments.

One of the disclosed embodiments is a method of operating a blast furnace, comprising

generating a regenerative methane gas from a by-product gas discharged from the blast furnace, and

blowing a blast gas and a reducing agent into the blast furnace from a tuyere,

wherein the blast gas is oxygen gas and the regenerative methane gas is used as at least part of the reducing agent.

[0023] First, the method of operating a blast furnace according to one of the

disclosed embodiments will be described, taking as an example the case where the method is applied to the blast furnace and blast furnace ancillary facility schematically illustrated in FIG. 1.

In the figure, reference sign 1 is a blast furnace, 2 is a tuyere, 3 is a methane gas generation device, 4 is a gas blowing device, 5 is a first dehydration device, 6 is a second dehydration device, and 7 is a burner.

As used herein, the term "blast furnace" includes shaft-type reducing furnaces.

[0024] [How to operate a blast furnace]

In the method of operating a blast furnace according to one of the disclosed embodiments, sinter, lump ore, and pellet (hereinafter also referred to as ore material), coke, etc., which are raw materials, are charged into the blast furnace from the head of the furnace (not illustrated). In addition, the blast gas and reducing agent are blown into the blast furnace 1 from the tuyere 2 provided at the bottom of the blast furnace. The reducing agent that is blown into the blast furnace 1 from the tuyere 2 is also called "blown reducing agent" to distinguish it from coke.

The carbon monoxide gas and hydrogen gas produced by the reaction between the blast gas and the reducing agent reduce the ore material charged into the blast furnace 1. In the reduction reaction of the ore material, carbon dioxide is produced. The carbon dioxide is then discharged from the head of the blast furnace as the by-product gas, along with the carbon monoxide and hydrogen that have not reacted with the ore material. The head of the blast furnace is under high pressure conditions of about 2.5 atm. Therefore, water vapor condenses due to the expansion and cooling of the by-product gas discharged from the head of the blast furnace (hereinafter also referred to as blast furnace by-product gas) as it returns to normal pressure. The condensate is then removed through the first dehydration device 5.

[0025] Then, at least a part of the blast furnace by-product gas is introduced into the methane gas generation device 3. Then, in the methane gas generation device 3, carbon monoxide and carbon dioxide contained in the blast furnace by-product gas are reacted with a hydrogen gas to produce a methane (CH₄) gas. Here, the methane gas obtained by reacting the blast furnace by-product gas is referred to as regenerative methane gas.

The hydrogen used to generate the regenerative methane gas may be supplied externally but is preferably produced by a method that generates as

little carbon dioxide as possible. For example, electrolysis of water can be used. The hydrogen gas does not have to be a gas with a hydrogen concentration of 100 % by volume, but to achieve a high concentration of methane in the regenerative methane gas, a gas with a high hydrogen concentration, specifically, a hydrogen gas with a hydrogen concentration of 80 % or more by volume is preferably used. The hydrogen concentration is more preferably 90 % or more by volume, and further preferably 95 % or more by volume. The hydrogen concentration may be 100 % by volume. The remainder gas other than hydrogen includes, for example, CO, CO₂, H₂S, CH₄, and N₂.

[0026] Then, by cooling the regenerative methane gas to room temperature, the water vapor in the regenerative methane gas is condensed. Then, in the second dehydration device 6, the condensate is removed.

[0027] Then, the regenerative methane gas is introduced into the gas blowing device 4. The gas blowing device 4 is connected to the methane gas generation device 3 via the second dehydration device 6. The gas blowing device 4 has a methane gas supply section that introduces the regenerative methane gas, which serves as the blown reducing agent, into the tuyere 2 of the blast furnace 1, and an oxygen gas supply section that introduces oxygen gas, which serves as the blast gas, into the tuyere of the blast furnace.

[0028] For example, as illustrated in FIG. 2A, the gas blowing device 4 comprises a coaxial multiple pipe having a central pipe 4-1 and an outer pipe 4-3. Then, the methane gas (regenerative methane gas and appropriately, external methane gas as described below) is introduced into the inner passage of the central pipe, which serves as the methane gas supply section (passage), and the oxygen gas is introduced into the annular pipe passage between the central pipe 4-1 and the outer pipe 4-3, which serves as the oxygen gas supply section (passage).

Another blown reducing agent, for example, pulverized coal, waste plastics, or reducing gas such as hydrogen gas or carbon monoxide gas, may be used together. The total blowing amount of the another blown reducing agent into the blast furnace is preferably 150 kg/t or less. Here, the unit of "kg/t" is the amount of the another blown reducing agent blown into the blast furnace in producing 1 t of hot metal.

When the another blown reducing agent is used, it may also be introduced into the methane gas supply section. When using pulverized coal

or waste plastics as the another blown reducing agent, it is preferable to provide, separately from the methane gas supply section, another reducing agent supply section (passage) through which the pulverized coal or waste plastics flow. In this case, as illustrated in FIG. 2B, for example, the gas blowing device 3 comprises a coaxial multiple pipe having, in addition to the central pipe 4-1 and outer pipe 4-3, an inner pipe 4-2 provided between the central pipe 4-1 and outer pipe 4-3. Then, the another blown reducing agent such as pulverized coal or waste plastics is introduced from the inner passage of the central pipe, which serves as the another reducing agent supply section. Further, methane gas is introduced from the annular pipe passage between the central pipe 4-1 and the outer pipe 4-3, which is the methane gas supply section, and oxygen is introduced from the annular pipe passage between the inner pipe 4-2 and the outer pipe 4-3, which is the oxygen gas supply section.

Since the use of oxygen gas at room temperature as the blast gas causes poor ignitability, it is preferable to provide the discharge section of the outer pipe that constitutes the oxygen gas supply section of the gas blowing device 4 with a porous structure to promote the mixing of the oxygen gas and the blown reducing agent.

[0029] It is not necessary to use the regenerative methane gas for the whole of the methane gas blown into the blast furnace from the tuyere (hereinafter referred to as "blown methane gas"), but a methane gas supplied from a separate line (also referred to as "external methane gas") may be used in accordance with the operation of the steelworks. In this case, a supply line of the external methane gas may be connected to the methane gas supply section of the gas blowing device 4, or to the another reducing agent supply section as described above. The external methane gas supply line may also be connected to the regenerative methane gas flow passage between the methane gas generation device 3 and the gas blowing device 4 (preferably between the second dehydration device 6 and the gas blowing device 4).

The external methane gas includes, for example, a methane gas derived from fossil fuels.

[0030] Then, as illustrated in FIGS. 2A and 2B, the blown reducing agent such as blown methane gas and the oxygen gas introduced from the gas blowing device 4 are mixed in the tuyere 2. Immediately after this mixed gas is blown into the blast furnace 1 from the tuyere 2, rapid ignition and rapid combustion occur. Then, a raceway 8 that is an area where the oxygen gas reacts with the

blown reducing agent such as blown methane gas and coke is formed in the blast furnace beyond the tuyere 2.

5 **[0031]** When the oxygen concentration in the blast gas increases, the amount of gas in the furnace decreases, and the temperature rise of the burden at the upper part of the blast furnace may be insufficient. In this case, as illustrated in FIG. 1, it is preferable to perform preheated-gas blowing, in which a part of the blast furnace by-product gas downstream of the first dehydration device 5 is partially combusted by the burner 7 to reach a temperature of about 800 °C to 1000 °C, and then blown into the blast furnace shaft section.

10 **[0032]** And in the method of operating a blast furnace according to one of the disclosed embodiments, it is important to use oxygen gas instead of hot blast (air heated to about 1200 °C) as the blast gas, as described above.

In detail, when hot blast (air heated to about 1200 °C) is used as the blast gas, the combustion gas contains nitrogen of about 50 % by volume, 15 which does not contribute to the combustion reaction, and thus the flame temperature in the raceway is hardly to be high. Therefore, when most of the reducing agent blown into the blast furnace is changed to methane gas from pulverized coal, the difference between the reaction heat in the pulverized coal-oxygen reaction and the reaction heat in the methane gas-oxygen reaction 20 described above will cause the tuyere-outlet temperature to drop, and eventually the tuyere-outlet temperature will fall below 2000 °C, which is the lower limit of the appropriate temperature. This results in the operational problems such as insufficient heating of the bottom of the blast furnace, pressure drop increase, and tapping failure. Further, since the blast furnace 25 by-product gas contains a large amount of nitrogen, it is necessary to separate the nitrogen from carbon monoxide and carbon dioxide in the process prior to the process of generating methane gas from the blast furnace by-product gas.

On the other hand, the use of oxygen gas as the blast gas can suppress the mixing of nitrogen gas, which does not contribute to the combustion 30 reaction, so that the tuyere-outlet temperature can be raised to a sufficient temperature. This means that the temperature of the flame in the raceway can be higher than when hot blast is used. Therefore, even when a large amount of methane is blown in from the tuyere as a reducing agent, the tuyere-outlet temperature can be controlled in the appropriate range of 2000 °C to 2400 °C.

35 Based on the above, it is important to use oxygen gas as the blast gas in the method of operating a blast furnace according to one of the disclosed

embodiments.

[0033] FIG. 8 illustrates, for conditions where hot blast (air heated to about 1200 °C) is used as the blast gas (hereinafter referred to as hot blast blowing condition) and where oxygen gas (oxygen concentration: 100 %) is used as the blast gas (hereinafter referred to as oxygen gas blowing condition), an example of the relationship between the consumption rate of circulating carbon atoms in the reducing agent (hereinafter referred to simply as the consumption rate of circulating carbon atoms) as described below and the tuyere-outlet temperature. In both conditions, the whole of the blown reducing agent is the regenerative methane gas (methane concentration: 99.5 %).

As illustrated in FIG. 8, under the hot blast blowing condition, when the consumption rate of circulating carbon atoms is 52 kg/t or more (i.e., the blowing amount of regenerative methane is 97 Nm³/t or more), the tuyere-outlet temperature falls below 2000 °C, which is the lower limit of the appropriate temperature. Thus, under the hot blast blowing condition commonly used, a consumption rate of circulating carbon atoms of 55 kg/t or more, especially 60 kg/t or more causes a decrease in the tuyere-outlet temperature, which makes stable operation impossible.

On the other hand, under the oxygen gas blowing condition, the tuyere-outlet temperature is kept at 2000 °C or higher even when the consumption rate of circulating carbon atoms is 55 kg/t or higher, or even 60 kg/t or higher.

Under the oxygen gas blowing condition illustrated in FIG. 8, the tuyere-outlet temperature exceeds 2400 °C, which is the upper limit of the appropriate temperature, in the range where the consumption rate of circulating carbon atoms is 55 kg/t to 80 kg/t. This is because the whole of the blown reducing agent is the regenerative methane. When the external methane gas is used as a part of the blown reducing agent, the tuyere-outlet temperature can be controlled in the range of 2000 °C to 2400 °C even when the consumption rate of circulating carbon atoms is in the range of 55 kg/t to 80 kg/t. Even when the whole of the blown reducing agent is the regenerative methane, the tuyere-outlet temperature can be controlled in the range of 2000 °C to 2400 °C by adjusting the oxygen concentration of the oxygen gas.

[0034] The oxygen concentration in the oxygen gas is preferably 80 % or more by volume. In detail, when the oxygen concentration in the oxygen gas is low, the amount of gas introduced into the blast furnace, and thus the pressure drop in the blast furnace may increase, resulting in lower productivity.

Further, during the repetition of the gas circulation, the concentration of methane gas in the regenerative methane gas decreases relatively. Therefore, the oxygen concentration in the oxygen gas is preferably 80 % or more by volume. The oxygen concentration is more preferably 90 % or more by volume, and further preferably 95 % or more by volume. In particular, when the oxygen concentration is 90 % or more by volume, the methane gas concentration in the regenerative methane gas can be maintained at a high level (about 90 % by volume) without the need for external methane gas supply even when the blast furnace is operated beyond the normal operating period, which is very advantageous. The oxygen concentration may be 100 % by volume.

The remainder gas other than oxygen in the oxygen gas may include, for example, nitrogen, carbon dioxide, and argon.

[0035] The methane concentration of the blown methane gas composed of regenerative methane gas or regenerative methane gas and external methane gas is preferably 80 % or more by volume.

In detail, when the methane concentration in the blown methane gas is low, the amount of gas blown into the blast furnace, and thus the pressure drop in the blast furnace may increase, resulting in lower productivity. Further, during the repetition of the gas circulation, the methane concentration in the regenerative methane gas decreases relatively. Therefore, the methane concentration of the blown methane gas is preferably 80 % or more by volume percent. The methane concentration of the blown methane gas is more preferably 90 % or more by volume, and further preferably 95 % or more by volume. The methane concentration of the blown methane gas may be 100 % by volume.

For the same reason, the methane concentration of each of the regenerative methane gas and external methane gas is preferably 80 % or more by volume. The methane concentration of each of the regenerative methane gas and external methane gas is more preferably 90 % or more by volume, and further preferably 95 % or more by volume. The methane concentration of each of the regenerative methane gas and external methane gas may be 100 % by volume.

The remainder gas other than methane in the blown methane gas, regenerative methane gas, and external methane gas may include, for example, carbon monoxide, carbon dioxide, hydrogen and hydrocarbons, and an impurity gas such as nitrogen.

When the methane concentration in the regenerative methane gas decreases, the methane concentration in the blown methane gas can be kept high, by, for example, decreasing the ratio of the regenerative methane gas in the blown methane gas while increasing the ratio of the external methane gas with high methane concentration.

[0036] In the method of operating a blast furnace according to one of the disclosed embodiments, the consumption rate of circulating carbon atoms in the reducing agent is preferably 55 kg/t or more and more preferably 60 kg/t or more.

The consumption rate of circulating carbon atoms is a carbon equivalent mass of the regenerative methane gas that is blown into the blast furnace as the reducing agent for producing 1 t of hot metal, and is obtained by the following equation:

$$[\text{Consumption rate of circulating carbon atoms (kg/t)}] = [\text{Mass of methane in regenerative methane gas blown into blast furnace as reducing agent (kg)}] \times (12/16) \div [\text{Production amount of hot metal (t)}].$$

[0037] For stable operation of the blast furnace, it is generally necessary to control the tuyere-outlet temperature in the range of 2000 °C to 2400 °C. Therefore, when hot blast (air heated to about 1200 °C) is used as the blast gas, methane gas can be blown into the blast furnace only up to about 52 kg/t of carbon equivalent mass in order to keep the tuyere-outlet temperature in the aforementioned range. In detail, even when the whole of the methane gas blown into the blast furnace is the regenerative methane gas, the consumption rate of circulating carbon atoms in the reducing agent is only about 52 kg/t.

[0038] On the other hand, in the method of operating a blast furnace according to one of the disclosed embodiments, even with a significant increase in blowing amount of methane gas, the tuyere-outlet temperature can be controlled in the range of 2000 °C to 2400 °C. Therefore, the consumption rate of circulating carbon atoms in the reducing agent can be increased to 55 kg/t or more, and even 60 kg/t or more. This will increase the use of the regenerative methane gas derived from carbon monoxide and carbon dioxide contained in the blast furnace by-product gas, further reducing carbon dioxide emissions from the blast furnace. The consumption rate of circulating carbon atoms in the reducing agent is preferably 80 kg/t or more, and more preferably 90 kg/t or more. No upper limit is placed on the consumption rate of circulating carbon atoms in the reducing agent, but the upper limit is preferably

110 kg/t or less.

The consumption rate of circulating carbon atoms in the reducing agent can be controlled by adjusting the amount of the regenerative methane gas in the blown reducing agent blown into the tuyere.

5 In particular, by setting the ratio of the regenerative methane gas in the blown methane gas to 80 % or more by volume, preferably 90 % or more by volume, a high carbon dioxide emission reduction effect can be achieved.

[0039] As illustrated in FIG. 3, the regenerative methane gas may be generated from a part of the blast furnace by-product gas and a surplus of the blast furnace by-product gas may be supplied to the steelworks. Furthermore, as illustrated
10 in FIG. 4, if there is a surplus of the regenerative methane gas, the surplus may be supplied to the steelworks.

[0040] The blowing amount of oxygen gas and reducing agent, as well as other operating conditions, are not limited and can be appropriately determined
15 according to the capacity of the blast furnace and the like.

[0041] [Blast furnace ancillary facility]

The blast furnace ancillary facility according to one of the disclosed embodiments is a blast furnace ancillary facility used in the method of operating a blast furnace as described above, comprising

20 a methane gas generation device that generates the regenerative methane gas from the by-product gas, and

a gas blowing device having a methane gas supply section that introduces the regenerative methane gas into the tuyere of the blast furnace and an oxygen gas supply section that introduces the oxygen gas into the tuyere of
25 the blast furnace.

[0042] Here, the methane gas generation device has, for example, a blast furnace by-product gas intake section, a hydrogen gas intake section, and a reaction section. In the reaction section, the blast furnace by-product gas taken in from the blast furnace by-product gas intake section and the hydrogen
30 gas taken in from the hydrogen gas intake section are reacted to produce the regenerative methane gas. Since the reaction to produce the methane gas generates heat, the reaction section is preferably equipped with a cooling mechanism.

[0043] As described above, for example, as illustrated in FIG. 2A, the gas blowing device comprises a coaxial multiple pipe having a central pipe 4-1 and
35 an outer pipe 4-3. Then, the methane gas (regenerative methane gas and

appropriately, external methane gas as described below) is introduced into the inner passage of the central pipe, which serves as the methane gas supply section (passage), and oxygen gas is introduced into the annular pipe passage between the central pipe 4-1 and the outer pipe 4-3, which serves as the oxygen gas supply section (passage).

Another blown reducing agent, for example, pulverized coal, waste plastics, or reducing gas such as hydrogen gas or carbon monoxide gas, may be used together.

When the another blown reducing agent is used, it may also be introduced into the methane gas supply section. When using pulverized coal or waste plastics as the another blown reducing agent, it is preferable to provide, separately from the methane gas supply section, another reducing agent supply section (passage) through which the pulverized coal or waste plastics flow. In this case, as illustrated in FIG. 2B, for example, the gas blowing device comprises a coaxial multiple pipe having, in addition to the central pipe 4-1 and outer pipe 4-3, an inner pipe 4-2 provided between the central pipe 4-1 and outer pipe 4-3. Then, the another blown reducing agent such as pulverized coal or waste plastics is introduced from the inner passage of the central pipe, which serves as the another reducing agent supply section. Further, methane gas is introduced from the annular pipe passage between the central pipe 4-1 and the outer pipe 4-3, which is the methane gas supply section, and oxygen is introduced from the annular pipe passage between the inner pipe 4-2 and the outer pipe 4-3, which is the oxygen gas supply section.

EXAMPLES

[0044] Using the blast furnace and blast furnace ancillary facility schematically illustrated in FIGS. 1 and 3 to 7, blast furnace operation was conducted under the conditions listed in Table 1, and the tuyere-outlet temperature and carbon dioxide emissions from the blast furnace during operation were evaluated. The evaluation results are also listed in Table 1.

In FIGS. 5-7, reference sign 9 is a hot air oven, 10 is a gas separation device, and 11 is a dehydration device for hot air oven exhaust gas.

[0045] In Example 1, the blast furnace and blast furnace ancillary facility schematically illustrated in FIG. 1 were used to generate a regenerative methane gas from a part of a blast furnace by-product gas, and a surplus of the blast furnace by-product gas was supplied to a steelworks. The whole of the

blown reducing agent was the regenerative methane gas, and a surplus of the regenerative methane gas was supplied to the steelworks.

5 In Example 2, the blast furnace and blast furnace ancillary facility schematically illustrated in FIG. 3 were used to generate a regenerative methane gas from a part of a blast furnace by-product gas, and a surplus of the blast furnace by-product gas was supplied to a steelworks. The whole of the blown reducing agent was the regenerative methane gas, and the amount of the regenerative methane gas generated was adjusted so that no surplus of the regenerative methane gas was generated.

10 In Example 3, the blast furnace and blast furnace ancillary facility schematically illustrated in FIG. 4 were used to generate a regenerative methane gas from the whole of a blast furnace by-product gas. The whole of the blown reducing agent was the regenerative methane gas, and a surplus of the regenerative methane gas was supplied to the steelworks.

15 In Examples 4 and 5, the blast furnace and blast furnace ancillary facility schematically illustrated in FIG. 3 were used to generate a regenerative methane gas from a part of a blast furnace by-product gas, and a surplus of the blast furnace by-product gas was supplied to a steelworks. As the blown reducing agent, in addition to the regenerative methane gas, an external methane gas derived from fossil fuels was also used .

20 [0046] On the other hand, in Comparative Example 1, the blast furnace and blast furnace ancillary facility schematically illustrated in FIG. 5 were used. In detail, Comparative Example 1 is a general method of operating a blast furnace that uses hot blast (air heated to about 1200 °C (oxygen concentration: about 21 % to 25 % by volume)) as the blast gas and pulverized coal as the
25 blown reducing agent. A regenerative methane gas was not produced from a blast furnace by-product gas.

In Comparative Example 2, the blast furnace and blast furnace ancillary facility schematically illustrated in FIG. 6 were used. Hot blast (air heated to
30 about 1200 °C (oxygen concentration: about 21 % to 25 % by volume)) was used as the blast gas and a regenerative methane gas was used as the blown reducing agent. Before generating the regenerative methane gas, carbon monoxide and carbon dioxide were separated from a blast furnace by-product gas, and the regenerative methane gas was generated from the separated carbon
35 monoxide and carbon dioxide.

In Comparative Example 3, the blast furnace and blast furnace ancillary

facility schematically illustrated in FIG. 7 were used. Hot blast (air heated to about 1200 °C (oxygen concentration: about 21 % to 25 % by volume)) was used as the blast gas and a regenerative methane gas was used as the blown reducing agent. In the generation of the regenerative methane gas, a by-product gas of a hot air oven (hereinafter also referred to as hot air oven exhaust gas) was used instead of a blast furnace by-product gas. Then, carbon dioxide was separated from the hot air oven exhaust gas, and the regenerative methane gas was generated from the separated carbon dioxide.

5
10 In Comparative Example 4, the blast furnace and blast furnace ancillary facility schematically illustrated in FIG. 1 were used to generate a regenerative methane gas from a part of a blast furnace by-product gas, and a surplus of the blast furnace by-product gas was supplied to a steelworks. As the blown reducing agent, in addition to the regenerative methane gas, an external methane gas derived from fossil fuels was also used .

15 In Comparative Example 5, as with Comparative Example 2, the blast furnace and blast furnace ancillary facility schematically illustrated in FIG. 6 were used. Comparative Example 5 had the same conditions as Comparative Example 2, except that the blown methane gas ratio was increased.

[0047] For the purpose of comparison, the specifications of the blast furnaces were standardized as much as possible. In detail, the shaft efficiency was 94 % and the heat loss was 150000 kcal/t.

The unit "kcal/t" refers to the amount of heat loss (kcal) generated in producing 1 t of hot metal. Similarly, the unit "kg/t" used for coke rate, for example, means the amount of coke (kg) used to produce 1 t of hot metal, etc. Further, the unit "Nm³/t" used for the blown methane ratio refers to the amount of methane (Nm³) in the blown methane gas that is blown into the blast furnace to produce 1 t of hot metal (the blown methane ratio is the sum of the regenerative methane ratio and the external methane ratio, but the regenerative methane gas contains a small amount of remainder gas other than methane. The values of the regenerative methane ratio and external methane ratio listed in Table 1 are both methane amounts excluding the small amount of remainder gas other than methane and are obtained by rounding off one decimal place. Therefore, each of the blown methane ratios listed in Table 1 is sometimes different from the sum of the corresponding regenerative methane ratio and external methane ratio).

35 In addition, the item name of "Blast furnace Input C" in Table 1 refers

to the mass (kg) of carbon atoms of external origin (specifically contained in coke, pulverized coal, and the external methane gas) used to produce 1 t of hot metal.

[0048]

Table 1

			Example 1	Example 2	Example 3	Example 4	Example 5	
Blast furnace specification	Shaft efficiency	-	0.94	0.94	0.94	0.94	0.94	
	Heat loss	kcal/t	15000	15000	15000	15000	15000	
	Coke rate	kg/t	338	338	338	338	338	
	Reducing agent (Brown reducing agent)	Pulverized coal ratio	kg/t	0	0	0	0	0
		Blown methane ratio	Nm ³ /t	200	200	200	200	200
		Regenerative methane ratio	Nm ³ /t	200	200	200	103	112
		External methane ratio	Nm ³ /t	0	0	0	98	88
	Blast gas	Supply amount	Nm ³ /t	321	321	321	321	321
		Supply temperature	°C	25	25	25	25	25
		Type	-	Oxygen gas	Oxygen gas	Oxygen gas	Oxygen gas	Oxygen gas
		Oxygen concentration	% by volume	100	100	100	100	100
Regeneration amount of blast furnace by-product gas		Nm ³ /t	1034	1034	1034	1034	1034	
Gas separation process	Presence/absence of separation process	-	Absent	Absent	Absent	Absent	Absent	
	Gas type before separation	-	-	-	-	-	-	
	Gas amount before separation	Nm ³ /t	-	-	-	-	-	
	Gas type after separation	-	-	-	-	-	-	
	Gas amount after separation	Nm ³ /t	-	-	-	-	-	

Table 1 (cont'd)

			Example 1	Example 2	Example 3	Example 4	Example 5
Methane gas generation process	Raw material gas type	-	Blast furnace by- product gas	Blast furnace by- product gas	Blast furnace by- product gas	Blast furnace by- product gas	Blast furnace by- product gas
	Raw material gas amount	Nm ³ /t	527	264	1034	135	147
	Hydrogen gas supply amount	Nm ³ /t	1301	651	2554	334	364
	Generation amount of regenerated methane gas	Nm ³ /t	402	201	788	103	112
	Methane concentration of regenerated methane gas	% by volume	99.6	99.6	99.6	99.6	99.6
Gas distribution	Amount of regenerated methane gas in blown methane gas	Nm ³ /t	201	201	201	103	112
	Surplus amount of regenerated methane gas (supply amount to steelworks)	Nm ³ /t	201	0	587	0	0
	Surplus amount of blast furnace by-products gas (supply amount to steelworks)	Nm ³ /t	507	770	0	899	886
C balance	Consumption rate of circulating carbon atoms	kg/t	107	107	107	55	60
	Blast furnace Input C	kg/t	290	290	290	343	338
Evaluation results	Amount of CO ₂ emitted from blast furnace to outside	kg/t	1064	1064	1064	1256	1238
	Tuyere-outlet temperature	°C	2046	2046	2046	2046	2046

Table 1 Cont'd

			Comparative Example 1	Comparative Example 2	Comparative Example 3	Comparative Example 4	Comparative Example 5	
Blast furnace specification	Shaft efficiency	-	0.94	0.94	0.94	0.94	0.94	
	Heat loss	kcal/t	15000	15000	15000	15000	15000	
	Coke rate	kg/t	331	410	410	338	406	
	Reducing agent (Brown reducing agent)	Pulverized coal ratio	kg/t	170	0	0	0	0
		Blown methane ratio	Nm ³ /t	0	97	97	200	103
		Regenerative methane ratio	Nm ³ /t	0	97	97	75	103
		External methane ratio	Nm ³ /t	0	0	0	126	0
	Blast gas	Supply amount	Nm ³ /t	1006	1053	1053	321	1057
		Supply temperature	°C	1200	1200	1200	25	1200
		Type	-	Hot blast	Hot blast	Hot blast	Oxygen gas	Hot blast
		Oxygen concentration	% by volume	25	25	25	100	25
Regeneration amount of blast furnace by-product gas	Nm ³ /t	1517	1587	1587	1034	1594		
Gas separation process	Presence/absence of separation process	-	Absent	Present	Present	Absent	Present	
	Gas type before separation	-	-	Blast furnace by- product gas	Hot air oven exhaust gas		Blast furnace by- product gas -	
	Gas amount before separation	Nm ³ /t	-	232	704	-	246	
	Gas type after separation	-	-	CO,CO ₂	CO ₂	-	CO, CO ₂	
	Gas amount after separation	Nm ³ /t	-	97	179	-	103	

Table 1 Cont'd

			Comparative Example 1	Comparative Example 2	Comparative Example 3	Comparative Example 4	Comparative Example 5
Methane gas generation process	Raw material gas type	-	-	CO, CO	CO ₂	Blast furnace by-product gas	CO, CO ₂
	Raw material gas amount	Nm ³ /t	-	97	179	98	103
	Hydrogen gas supply amount	Nm ³ /t	-	342	715	243	360
	Generation amount of regenerated methane gas	Nm ³ /t	-	97	179	75	103
	Methane concentration of regenerated methane gas	% by volume	-	100.0	100.0	99.6	100.0
Gas distribution	Amount of regenerated methane gas in blown methane gas	Nm ³ /t	-	97	97	75	103
	Surplus amount of regenerated methane gas (supply amount to steelworks)	Nm ³ /t	-	0	81	0	0
	Surplus amount of blast furnace by-products gas (supply amount to steelworks)	Nm ³ /t	1144	960	1192	935	951
C balance	Consumption rate of circulating carbon atoms	kg/t	0	52	52	40	55
	Blast furnace Input C	kg/t	420	353	353	358	349
Evaluation results	Amount of CO ₂ emitted from blast furnace to outside	kg/t	1539	1293	1293	1311	1279
	Tuyere-outlet temperature	°C	2179	2000	2000	2046	1978

[0049] As indicated in Table 1, in all of the examples, the amount of carbon dioxide emitted from the blast furnace to the outside could be reduced while maintaining stable blast furnace operation by controlling the tuyere-outlet temperature in the range of 2000 °C to 2400 °C. In particular, in Examples 1 to 3, the amount of carbon dioxide emitted from the blast furnace to the outside could be significantly reduced.

On the other hand, Comparative Examples 1 to 4 did not provide sufficient carbon dioxide emission reduction effect. In Comparative Example 5, the blast furnace could not be stably operated because the tuyere-outlet temperature was lower than 2000 °C due to the increase in the amount of blown methane gas.

REFERENCE SIGNS LIST

- [0050]** 1: blast furnace
15 2: tuyere
3: methane gas generation device
4: gas blowing device
4-1: central pipe
4-2: inner pipe
20 4-3: outer pipe
5: first dehydration device
6: second dehydration device
7: burner
8: raceway
25 9: hot air oven
10: gas separation device
11: dehydration device for hot air oven exhaust gas

CLAIMS

1. A method of operating a blast furnace, comprising
generating a regenerative methane gas from a by-product gas discharged from the blast furnace, and
blowing a blast gas and a reducing agent into the blast furnace from a tuyere,
wherein the blast gas is an oxygen gas and the regenerative methane gas is used as at least part of the reducing agent,
wherein a consumption rate of circulating carbon atoms in the reducing agent is 55 kg/t or more, the consumption rate of circulating carbon atoms being a carbon equivalent mass of the regenerative methane gas that is blown into the blast furnace as the reducing agent for producing 1 t of hot metal,
wherein the oxygen gas has an oxygen concentration of 80 % to 100 % by volume, and
wherein the regenerative methane gas has a methane concentration of 80 % to 100 % by volume.
2. The method of operating a blast furnace according to claim 1, wherein a consumption rate of circulating carbon atoms in the reducing agent is 60 kg/t or more,
wherein the consumption rate of circulating carbon atoms is obtained by the following equation:
$$[\text{Consumption rate of circulating carbon atoms (kg/t)}] = [\text{Mass of methane in regenerative methane gas blown into blast furnace as reducing agent (kg)}] \times (12/16) \div [\text{Production amount of hot metal (t)}].$$
3. The method of operating a blast furnace according to claim 1 or 2, wherein the regenerative methane gas is generated from a part of the by-product gas and a surplus of the by-product gas is supplied to a steelworks.

4. The method of operating a blast furnace according to any one of claims 1 to 3, wherein a surplus of the regenerative methane gas is supplied to the steelworks.
5. A blast furnace ancillary facility used in the method of operating a blast furnace according to any one of claims 1 to 4, comprising
a methane gas generation device that generates the regenerative methane gas from the by-product gas, and
a gas blowing device having a methane gas supply section that introduces the regenerative methane gas into the tuyere of the blast furnace and an oxygen gas supply section that introduces the oxygen gas into the tuyere of the blast furnace.

FIG. 1

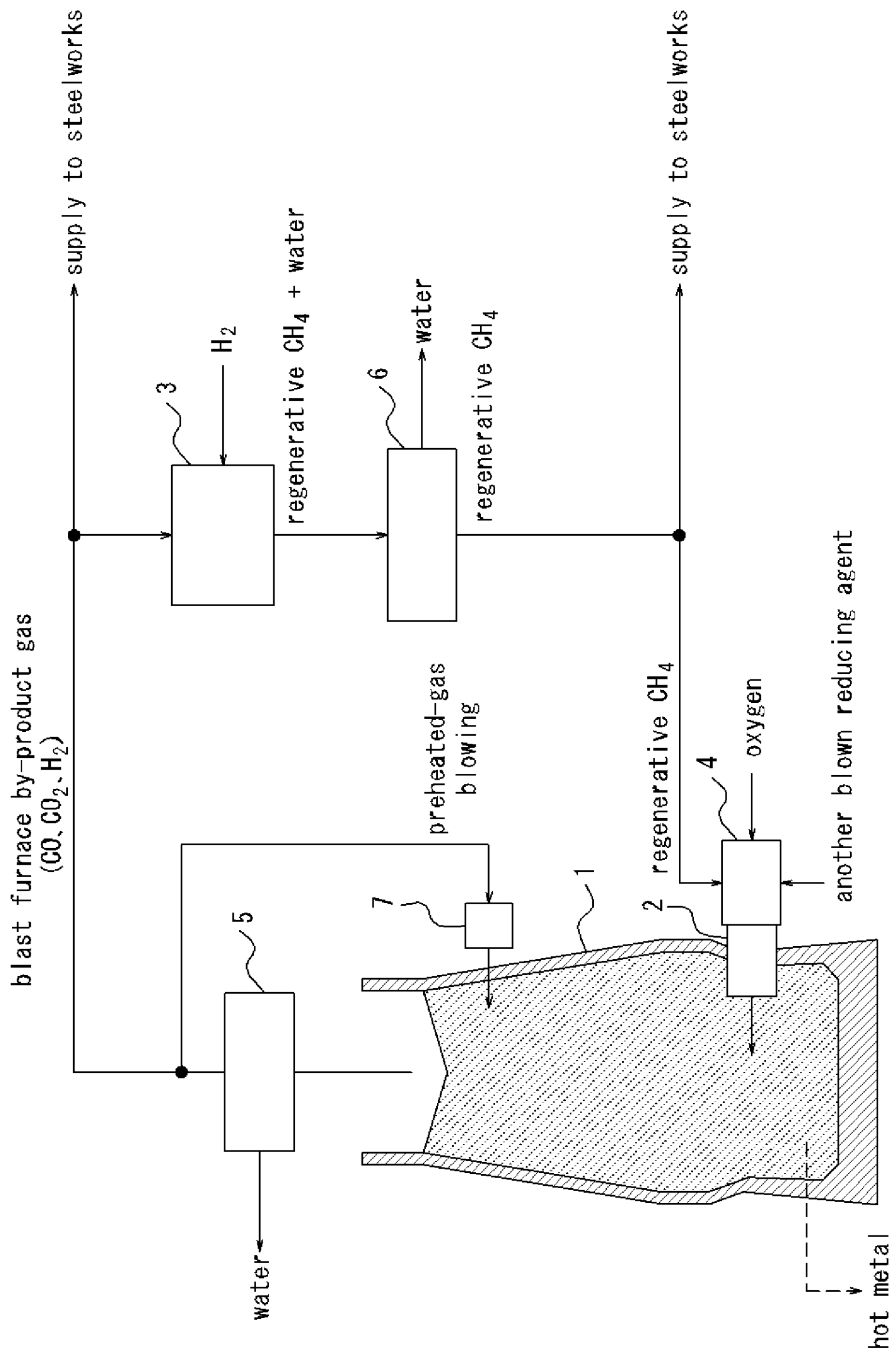

FIG. 2A

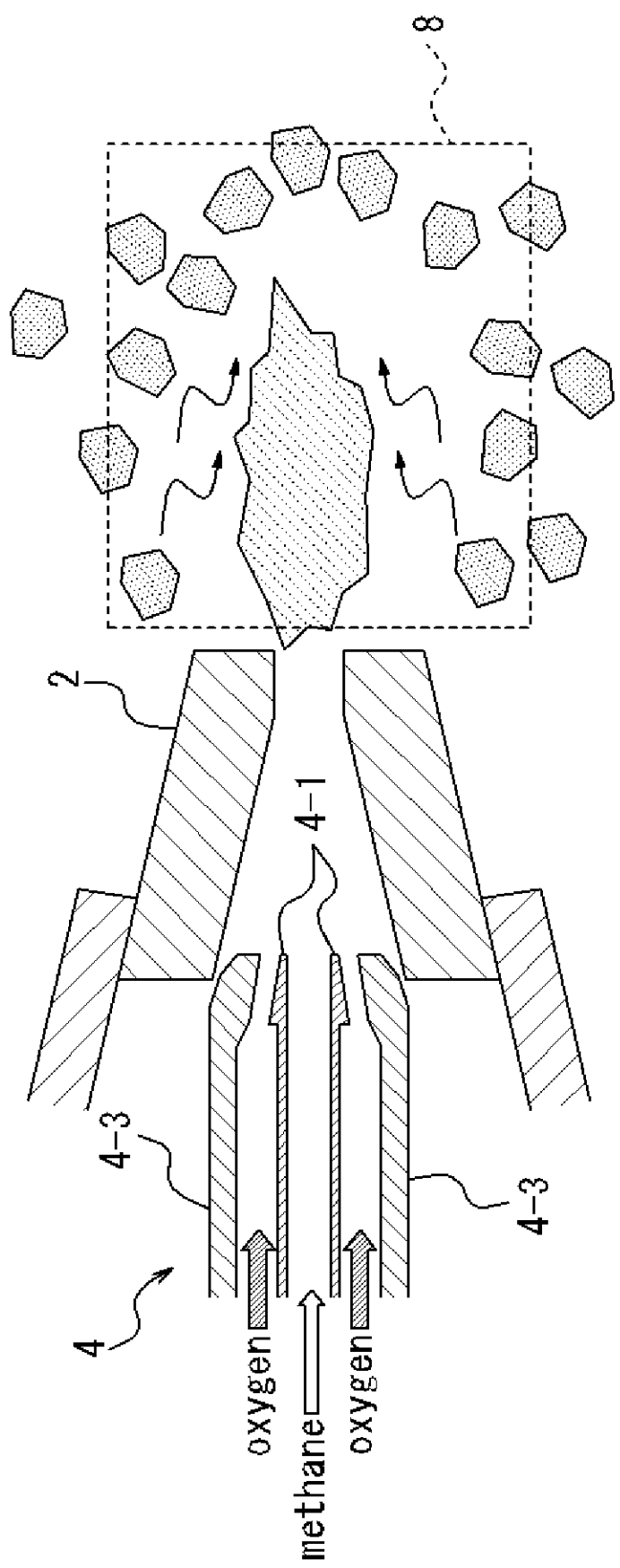

FIG. 2B

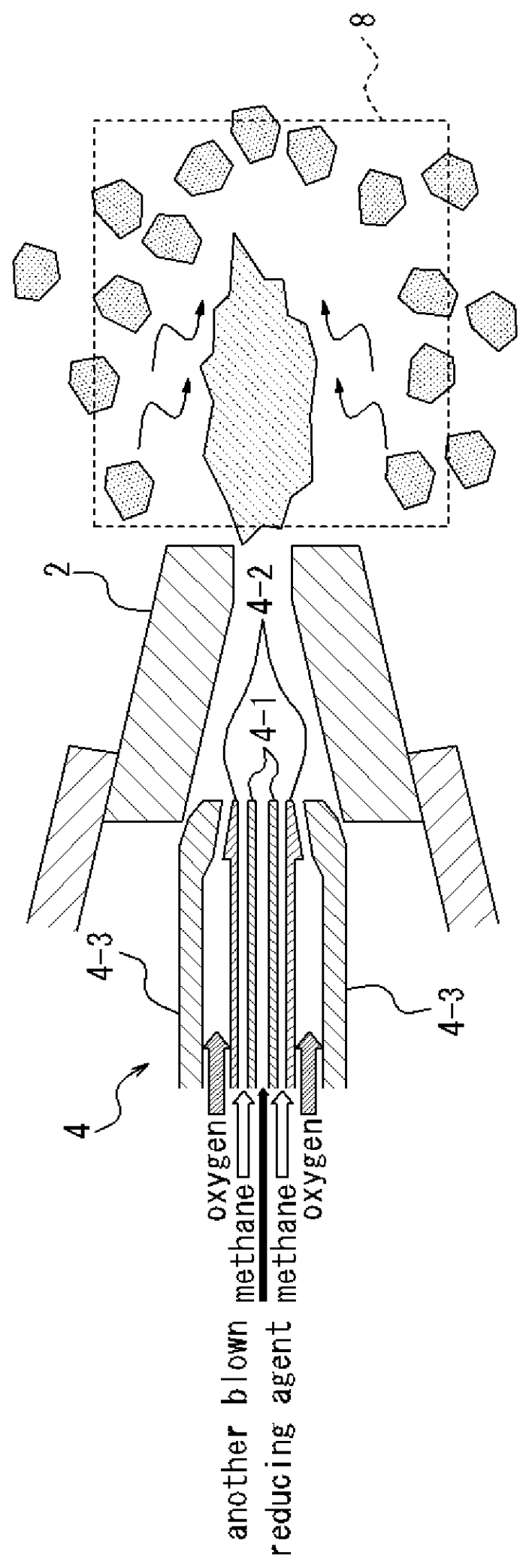

FIG. 3

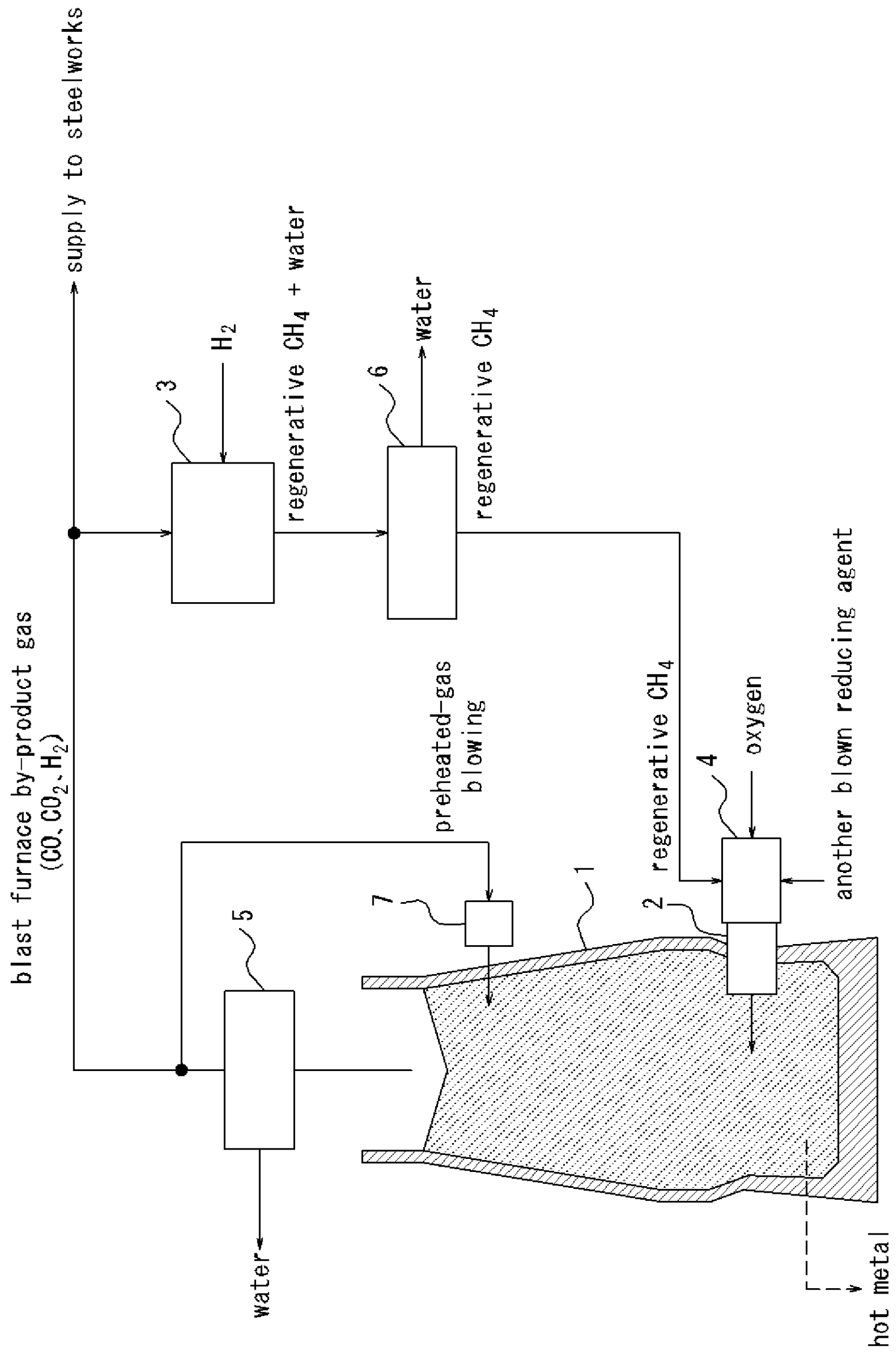

FIG. 4

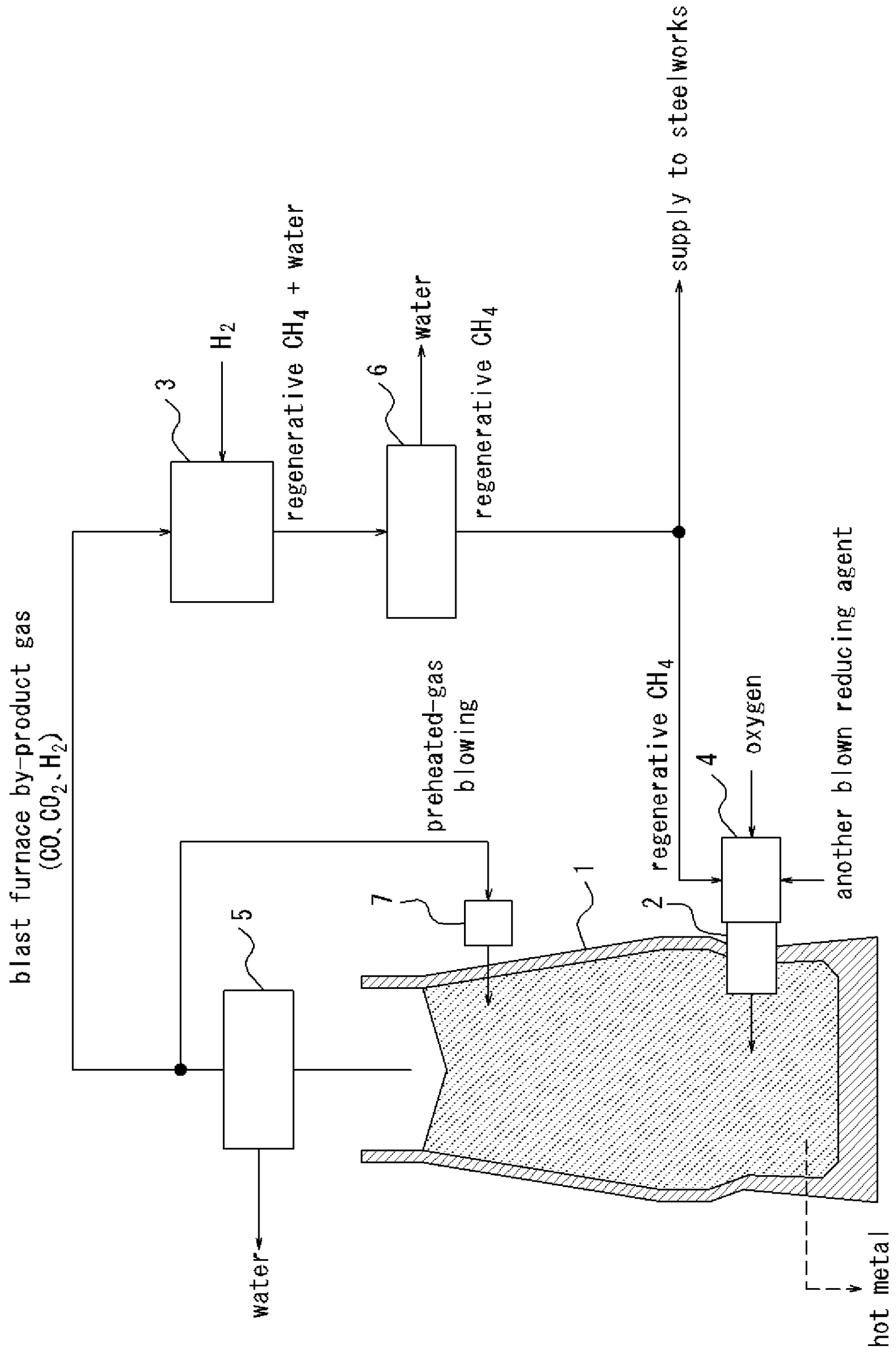

FIG. 5

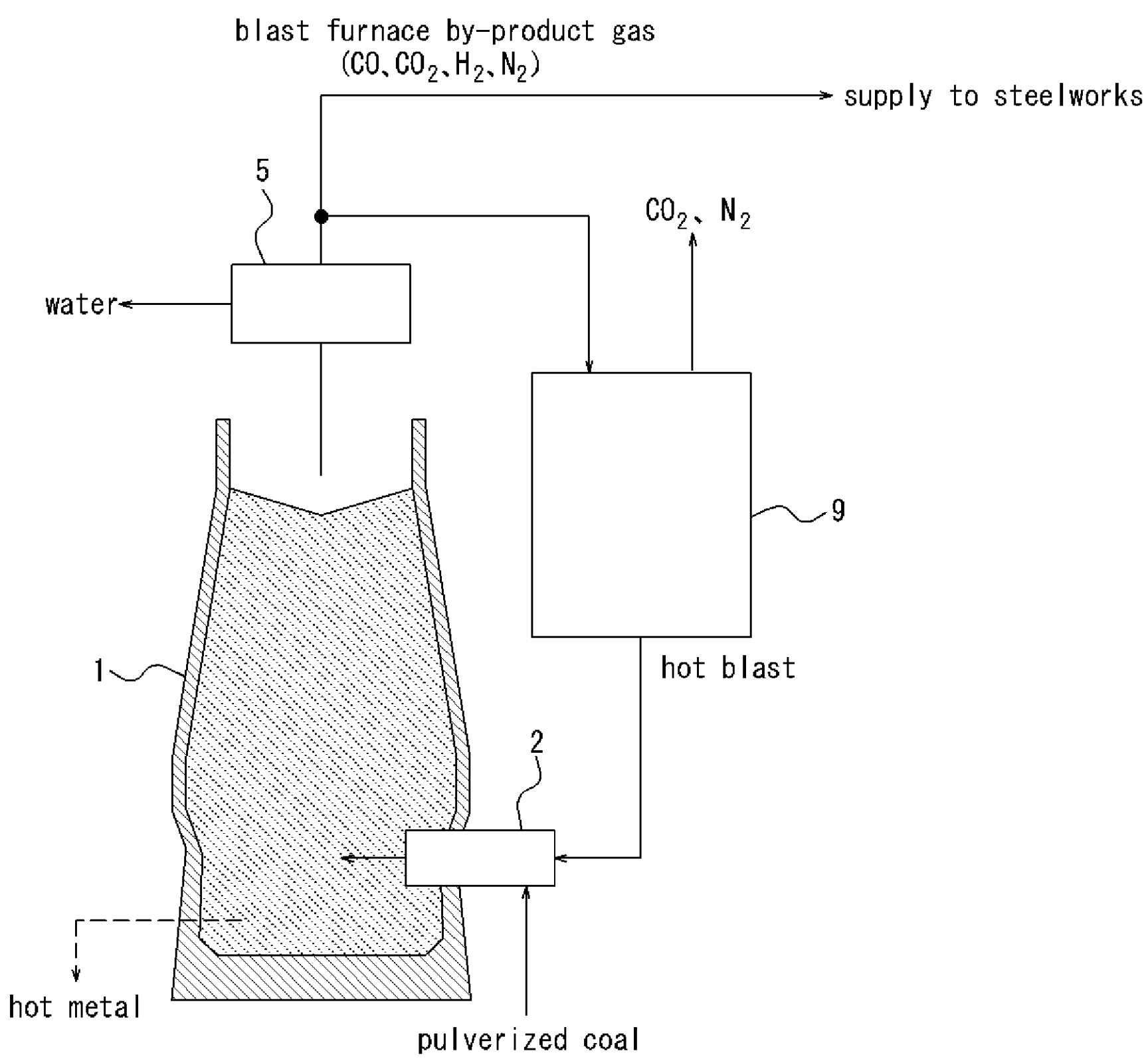

FIG. 6

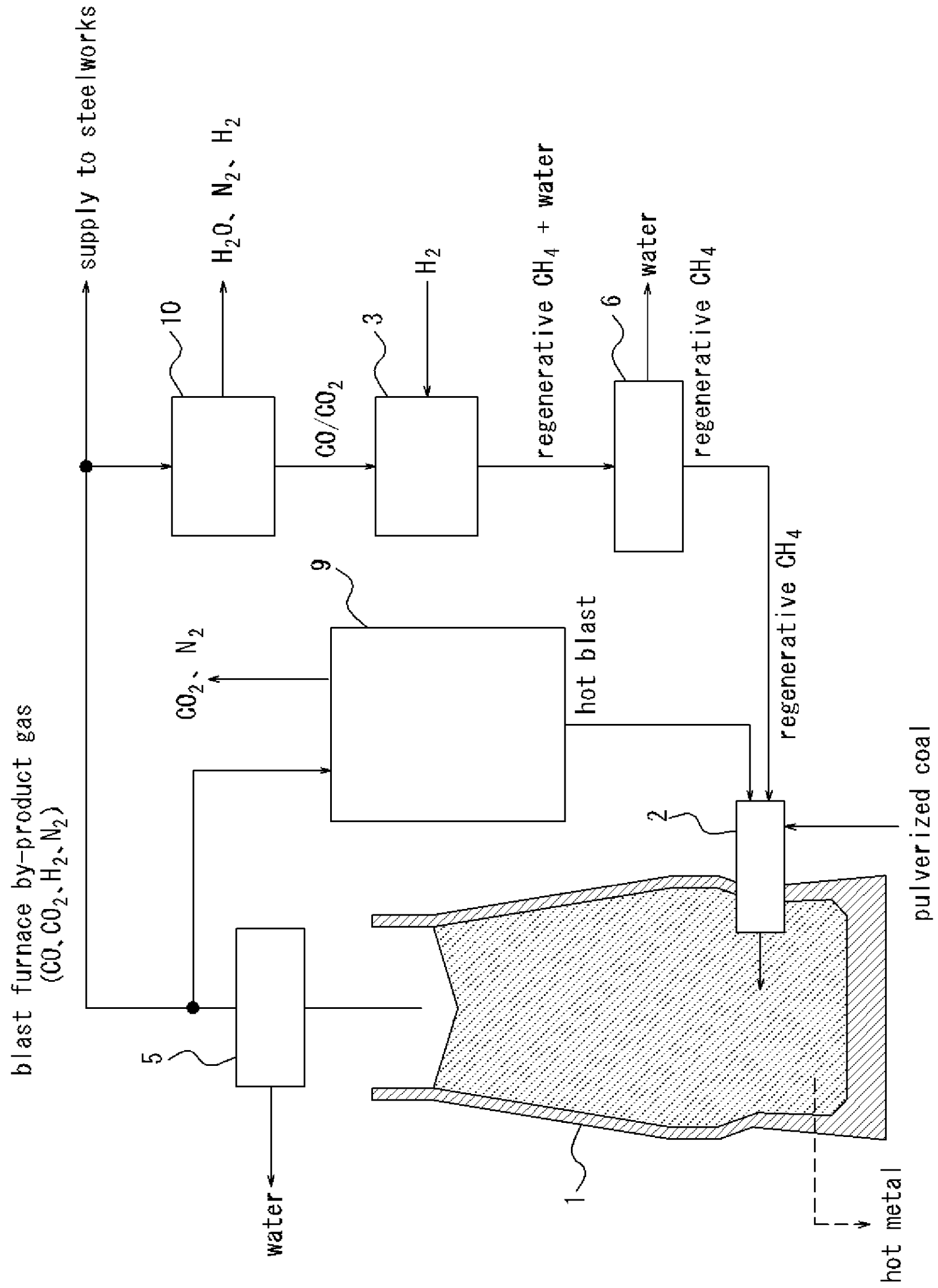

FIG. 7

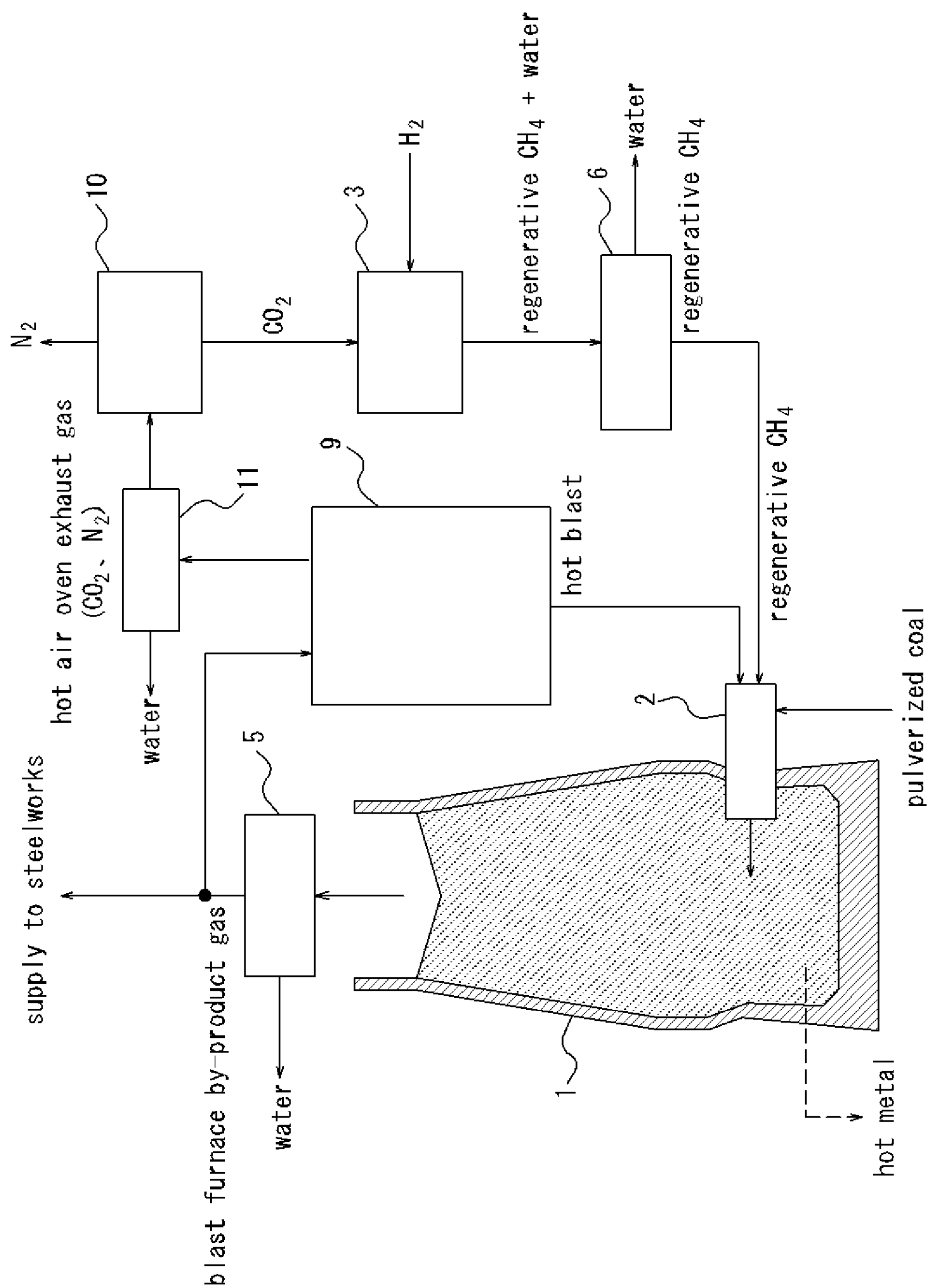

FIG. 8

