

(21) Application No 9919497.9	(51) INT CL ⁷ G11B 7/14 , G02B 27/42
(22) Date of Filing 18.08.1999	(52) UK CL (Edition S) G5R RB265 RLFX G2J J33X
(71) Applicant(s) The Secretary of State for Defence (Incorporated in the United Kingdom) DERA Headquarters, Ively Road, Pyestock, FARNBOROUGH, Hants, GU14 0LX, United Kingdom	(56) Documents Cited WO 99/46768 A1 WO 99/42994 A1
(72) Inventor(s) Alan Howard Greenaway Paul Michael Blanchard	(58) Field of Search UK CL (Edition R) G2J J33X , G5R RLFX RLF1 RLF2 INT CL ⁷ G02B 5/18 27/42 , G11B 7/125 7/135 7/14 Online: WPI;EPODOC;JAPIO
(74) Agent and/or Address for Service Anthony Oliver Bowdery D/IPR Formalities Section (DERA), Poplar 2, MOD(PE) Abbey Wood #19, BRISTOL, BS34 8JH, United Kingdom	

(54) Abstract Title
Imaging system suitable for use in multi-layer optical data storage applications

(57) A three dimensional imaging system is described which uses a diffraction grating to divide a wavefront and ancillary optical modules in each diffraction order to modify the imaging characteristics in each order. Object planes located at different distances from the diffraction grating are imaged simultaneously and spatially separated on a single image plane and correction for different levels of spherical aberration associated with different object planes is achieved. The system may be used for simultaneously imaging spatially separated data elements in a 3d optical storage medium.

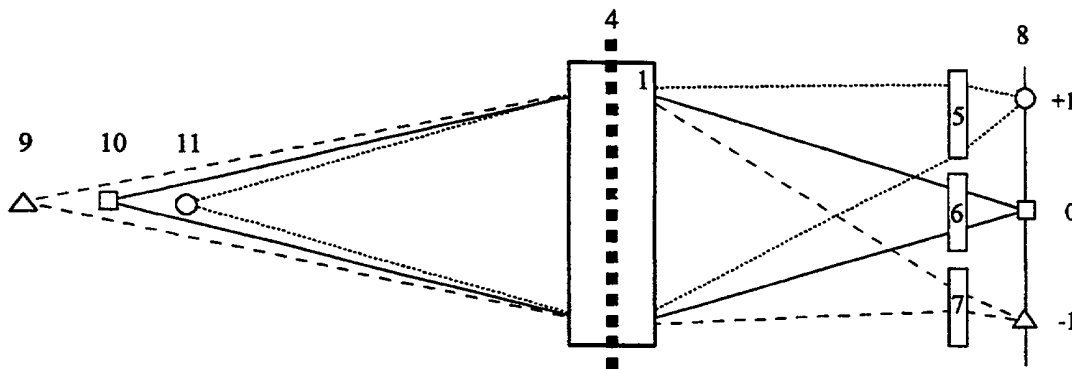
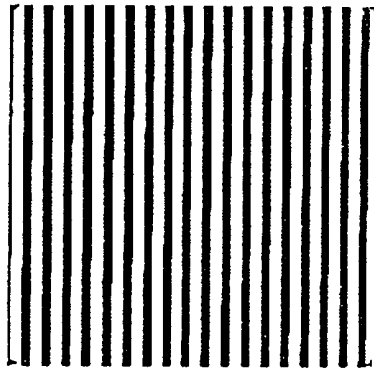
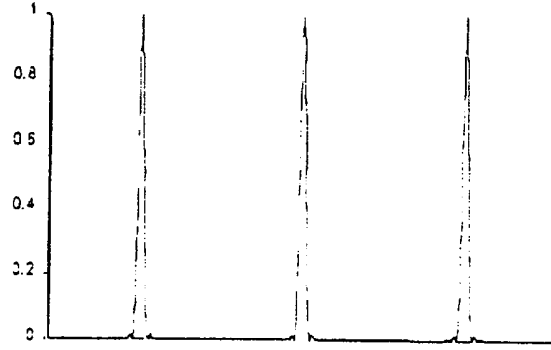

Figure 4



(a)



(b)

Figure 1

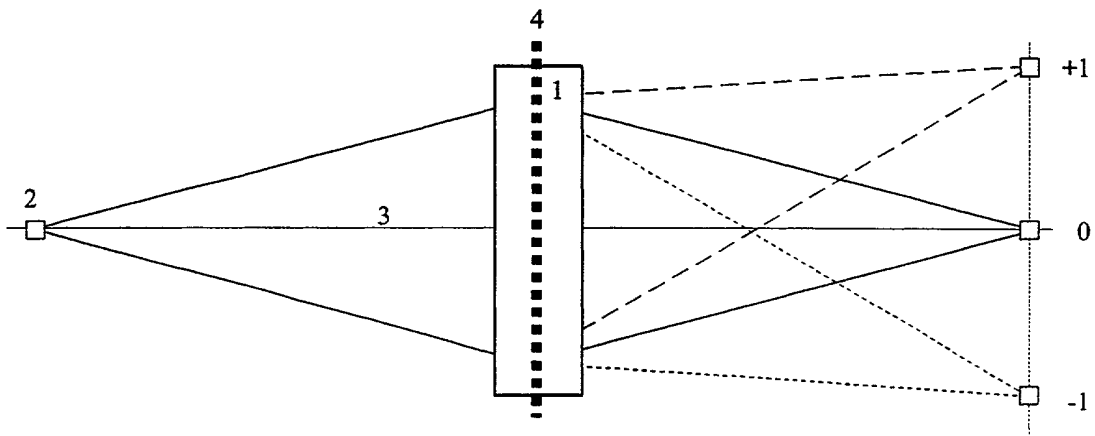

Figure 2

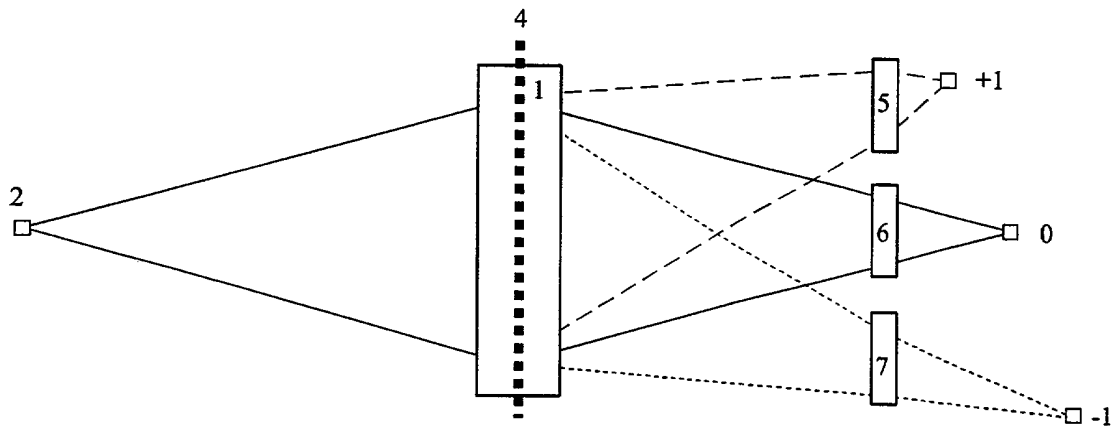

Figure 3

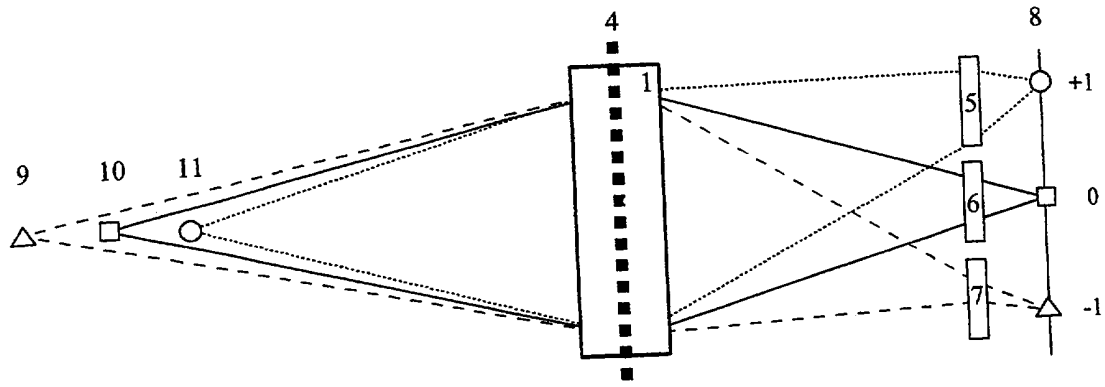

Figure 4

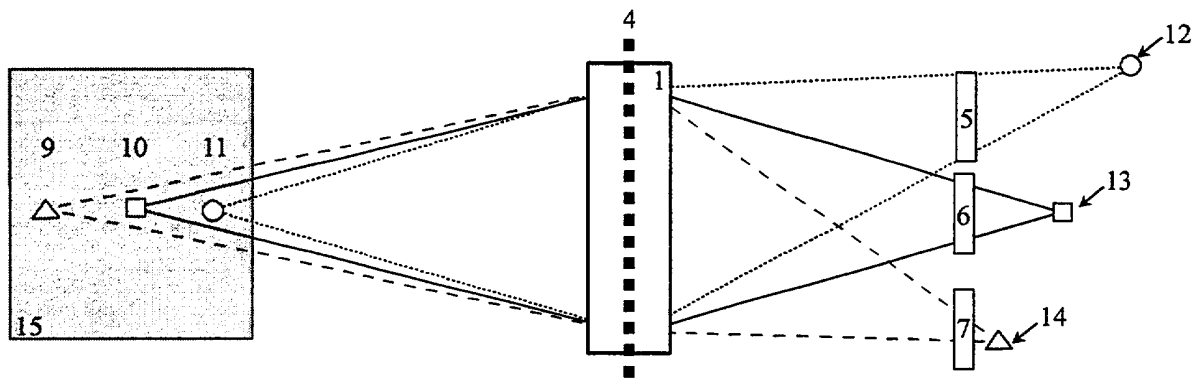

Figure 5

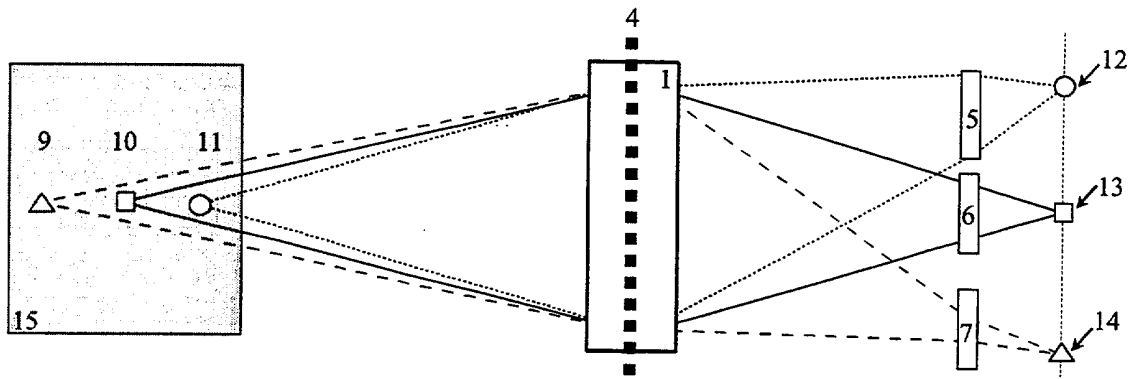

Figure 6

Imaging System

This invention relates to an optical system for producing multiple images of an object field, in which at least two images are produced simultaneously under different imaging conditions. The invention has applicability in fields including optical information storage, in vivo microscopy, ophthalmic optics, wavefront analysis and the imaging of three-dimensional object fields.

The use of a diffraction grating combined with an imaging lens to produce identical images of an object field in several diffraction orders is known. Phase-only gratings, amplitude-only gratings and phase and amplitude gratings may be used to change the fraction of the energy in each diffraction order and thus to vary the relative brightness of each identical image.

The imaging of a three-dimensional object using a 'through-focal series' is also known. By this method a sequence of images of the object are taken with the optical system focused on different planes in the object field. An alternative approach forms simultaneously a matrix of images recorded through a matrix of lenses, each of which provides a different focus condition.

A disadvantage of the 'through-focal series' is that because the images are recorded sequentially it is not suited to imaging the three-dimensional structure of dynamic processes. A disadvantage of the second approach is its complex design and that the resolution obtained is limited to the resolution delivered by the individual lenses in the array, the diameter of each of which (thus image resolution) is constrained by the space into which the array may be packed.

International patent application PCT 99/00658 describes another three-dimensional imaging system. However, a disadvantage of that system is that the optical transfer functions appropriate to the images formed in diffraction orders located symmetrically with respect to the undiffracted beam must suffer equal and opposite distortions compared to the beam in the zero order.

The storage of data in three dimensional, optically readable, storage media is also known (S Jutamulia and G M Stori, 'Three-Dimensional Optical Digital Memory', Optoelectronics -

Devices and Technologies Vol 10, No. 3, pp343-360, 1995 and K Kobayashi and S S Kano, 'Multi-Layered Optical Storage with Nonlinear Read/Write', Optical Review, Vol 2, No 1, pp20-23, 1995). These papers review the media and architecture for various three dimensional optical memories.

In a high performance, near diffraction limited optical system such as a compact disk player, all sources of wavefront aberrations must be considered. In a standard compact disk, the data layer is covered with a substrate several hundred microns thick. Propagation of light through this substrate (which is essentially a parallel plate) introduces spherical aberration, increasing the spot size on the data layer and degrading resolution. This effect is overcome in conventional, single layer, compact disk systems by building spherical aberration correction into the objective lens.

In a multi-layer optical data storage medium the degree of spherical aberration is dependent on the depth of the data layer below the surface, hence when reading from each distinct layer a different level of spherical aberration correction is required. An aberration-corrected objective lens is therefore not sufficient. Several patents on multi-layer optical data storage systems, which rely on a moving lens to focus at different depths, have suggested ways of performing 'active' spherical aberration correction. US 5202875 suggests using a stepped block of substrate material which is moved across the optical beam (using a voice coil motor) to a position dependent on the layer being read, such that the thickness of material that the beam passes through is constant. Other suggestions include a pair of prisms, one of which is translated, a rotating disk of variable thickness and movable compensation plates.

All of these approaches introduce additional moving parts and complexity into the system.

According to this invention, an apparatus for producing simultaneously a plurality of spatially separated images from an object field comprises:

an optical system arranged to produce an image associated with a first optical transfer function;

a diffraction grating arranged to produce, in concert with the optical system, images associated with each diffraction order ;

ancillary optical modules operating on individual diffraction orders and

means for detecting the images,

wherein the optical system, diffraction grating and detecting means are located on an optical axis, the diffraction grating is located in a suitable grating plane and the ancillary optical modules modify the optical transfer functions associated with the images.

The invention utilises a single lens or multiple lens system with a diffraction grating and ancillary optical modules to produce simultaneously a set of images of the object field in which each image in the set can correspond to an image of the object field recorded under different focus conditions but in which the full diameter of the lens system is exploited in each image in the set. For each image in the set, the full resolution and depth of field of the imaging means is exploited.

The ancillary optical modules contain optical elements which may also produce different amounts of spherical aberration in each diffraction order. This could be used to correct for spherical aberration in the associated optical system.

The grating used can be a single diffraction grating or a series of such gratings. The gratings used may be produced by computer-generated (digitised in space and/or in amplitude) or by analogue (e.g. interferometric) means.

The present invention allows for the optical transfer functions appropriate to the images formed in different diffraction orders to be independent of, identical with or correlated to the distortions applicable to any other diffraction order.

In the following descriptions detector means a detection means comprising a spatially-resolving system such as a pixellated array of detector elements e.g. a charge coupled device (CCD). For

applications where detection of the presence or absence of unresolved targets is required, the detector may comprise suitably-positioned, isolated detector elements.

The invention will now be described with reference to the following figures in which:

figure 1(a) shows schematically an amplitude-only diffraction grating and figure 1(b) shows the normalised intensity cross-section of the zero, +1 and -1 diffraction order images of a point source produced when such a grating is used in an imaging system;

figure 2 shows schematically the use of a diffraction grating to produce multiple images of a single object.

figure 3 shows schematically the use of ancillary optical modules within each diffraction order of the optical system of figure 1.

figure 4 shows schematically a simple imaging system of the current invention used to produce in-focus images of different object planes at a single detector plane;

figure 5 shows schematically a simple imaging system of the current invention used to produce in-focus images of different object planes within an optical storage medium at different detector planes;

figure 6 shows schematically a simple imaging system of the current invention used to produce in-focus images of different object planes within an optical storage medium at a single detector plane.

Although the following examples relate to application of the invention in the field of optics, this should not be seen as limiting as the general principles of the invention are applicable to other wavelengths of electromagnetic radiation.

Location of Components

A suitable grating plane would be any plane in which the beam cross-section spans at least 3 periods of the grating. The ancillary optical modules can be placed anywhere after the diffraction grating with the condition that each ancillary optical module intersects and operates on only one of the diffracted orders.

Diffraction Grating

A standard diffraction grating consists of alternate regularly spaced strips of different transmissivity, reflectivity or optical thickness. When the grating is used within an imaging system, multiple diffraction orders appear in the image plane in addition to the unscattered zero order. Each diffraction order contains the same information about the object field as the zero order, though with different levels of intensity dependent on details of the grating construction. Figure 1 shows, as an example, an amplitude grating and the images of a point object formed in the -1 , 0 and $+1$ diffraction orders. (each order normalised to unit intensity)

Phase Gratings

If an amplitude grating is used the zero order is always brighter than the $+1$, -1 and higher diffraction orders. The distribution of energy can be adjusted using a phase grating with two phase levels. For example, a phase step of π radians can completely eliminate the zero order, whilst putting more power into the $+1$ and -1 orders, or the phase step can be adjusted to 0.639π to place equal power into the 0 , $+1$ and -1 orders. With crossed gratings the use of more phase steps or combined amplitude and phase gratings can be used to adjust the intensities of the multiple diffraction orders.

The Invention

Referring to figure 2, an optical system (1), which may comprise a single lens or a multiple lens system, is designed to produce an in-focus image of an object (2) on the optical axis (3) in the normal focal plane. A diffraction grating (4) which is added to the optical system (1) produces additional images of the object (2) in the normal focal plane in its non-zero diffraction orders (+1 and -1 shown). The diffraction grating is here being used as a beam splitter.0

Referring to figure 3, ancillary optical modules (5, 6 and 7) are introduced into each diffraction order, such that each module acts to modify the optical transfer function (OTF) associated with a single diffraction order. Each ancillary optical module may modify the OTF in a different way and may consist of one or more lenses or other optical components. One or more diffraction orders may not contain an ancillary optical module.

Use of Defocus-Only Ancillary Optical Modules

If the ancillary optical modules modify the OTF associated with each diffraction order such that each order undergoes an additional degree of defocus, then the images of the object (2) will occur in a different image plane in each diffraction order (figure 3). The position of the image plane in each diffraction order is determined by the properties of the optical system (1) and the ancillary optical module that intercepts light scattered into the diffraction order. An example of an optical element that will produce an additional degree of defocus is a lens.

The function of the optical arrangement shown in figure 3 can be considered in a different way, as shown in figure 4, where a single detector plane (8) is considered. Ancillary defocus-only optical modules (5, 6 and 7) are placed in the -1, 0 and +1 diffracted beams, such that the three images formed in each diffraction order at the detector plane (8) correspond to in-focus images of three different object planes 9, 10 and 11. The zero order will be the sum of the out-of-focus images of objects 9 and 11 and an in-focus image of object 10. If the degree of defocus is sufficient, a good image of object 10 will result. Similarly, objects 9 and 11 are discernible in the +1 and -1 diffraction orders. The system therefore generates, side-by-side, simultaneous images of three different object planes at a single detector plane. The separation of the object planes can be arbitrarily controlled through choice of suitable ancillary optical modules.

Use of Spherical Aberration Ancillary Optical Modules

The ancillary optical modules can be designed to modify the OTF associated with each diffraction order such that each order undergoes an additional degree of spherical aberration (SA). An example of an optical element that will produce an additional degree of SA in a converging beam is a plane-parallel glass plate (J Braat, 'Analytical expressions for the wave-front aberration coefficients of a tilted plan-parallel plate', Applied Optics. Vol.36, No.32, 8459,1998).

Referring to figure 5, the optical system (1) and diffraction grating (4) can be used to image different object planes (9, 10 and 11) onto detectors (12, 13 and 14) in different image planes. When the different object planes are within a substrate (15), SA is introduced by the propagation of light through the substrate, to a degree dependent on the thickness of substrate above each plane. This SA degrades the images to a different extent in each diffraction order. Ancillary spherical aberration-only optical modules (5, 6 and 7) can be used in each diffraction order to correct for the SA introduced by the substrate, allowing diffraction limited imaging of multiple object planes simultaneously, with the different detectors.

This technique can be used to read from multi-layer optical data storage media. Referring to figure 5, the storage medium 15 now comprises discrete optically readable planes 9, 10 and 11 having individual data storage elements (not shown) located thereon and is illuminated by means not shown. The elements could, for example, be an area of the plane in which a hole or pit is used to designate a logical 1 and the absence of a hole or pit is used to designate a logical 0. However, this example is not limiting: other embodiments are known to, or would be obvious to, persons skilled in the art including multi-level systems in which the elements may exist in more than the two states of a binary system.

The data storage elements are imaged simultaneously at detectors 12, 13 and 14. The detectors are capable of producing a signal dependent on the state of the storage element and could be a photodiode or a photo transistor. Ancillary optical modules 5, 6 and 7 are designed to correct for the spherical aberration associated with each data layer producing images of diffraction limited size on the detectors.

The optical system 1 may be designed to correct for the spherical aberration associated with one data layer in the storage medium. In this case, the diffraction order imaging that layer would not require ancillary SA correction optics. Optical modules in other orders would be designed such that the combination of SA correction introduced by the optical system (1) and by the ancillary optical modules (5, 6 and 7) would correct for SA introduced by the substrate.

In order to facilitate interrogation of different data elements within each plane, the apparatus includes means (not shown) for effecting relative movement, in a direction perpendicular to optical axis, between the storage medium 15 and the rest of the apparatus. Such means might comprise an electromechanical arrangement known to a person skilled in the art.

Use of Defocus and Spherical Aberration Ancillary optical modules.

By combining defocus and spherical aberration functions into each ancillary optical module (for example using a lens and parallel plate combination) multiple object layers can be imaged simultaneously onto a single image plane with automatic spherical aberration correction for each object layer.

For example, in figure 6, the ancillary optical modules (5, 6 and 7) combine SA correction and defocus correction such that the images of each data layer (9, 10 and 11) are formed in the same image plane. The data storage elements are imaged simultaneously at detectors 12, 13 and 14, which are in the same plane. The ancillary optical modules simultaneously correct for the spherical aberration associated with each data layer producing images of diffraction limited size in the detector plane.

Claims

1. An apparatus for producing simultaneously a plurality of spatially separated images from an object field comprising:

an optical system arranged to produce an image associated with a first optical transfer function;

a diffraction grating arranged to produce, in concert with the optical system, images associated with each diffraction order ;

ancillary optical modules operating on individual diffraction orders and

means for detecting the images,

wherein the optical system and diffraction grating are located on an optical axis the diffraction grating is located in a suitable grating plane and the ancillary optical modules modify the optical transfer functions associated with the images.

2. The apparatus of claim 1 where the ancillary optical modules generate different amounts of defocus in the images associated with each diffraction order.

3. The apparatus of claim 1 where the ancillary optical modules generate different amounts of spherical aberration in the images associated with each diffraction order.

4. The apparatus of claim 1 where the ancillary optical modules generate different amounts of defocus and spherical aberration in the images associated with each diffraction order.

5. The apparatus of claims 3 and 4 where the spherical aberration of images associated with each diffraction order is arranged to correct for spherical aberration associated with the different thickness of substantially parallel plates in object space.

6. An apparatus according to claim 1 whereby the diffraction grating comprises a set of two or more diffraction gratings designed such that the various diffraction orders are spatially separated.

7. An apparatus according to claim 1 whereby the diffraction grating is any one of an amplitude-only diffraction grating, a phase only diffraction grating or a phase and amplitude diffraction grating and any one of a reflective or a transmissive grating and any of these in which the grating lines are not plane parallel.

8. An apparatus according to claim 1 whereby the grating is a two-level (binary), a multi-level (digitised) or a continuous-level (analogue) structure.

9. The apparatus of claim 1 where each object plane contains an array of elements, capable of existing in at least two states and in which the detector means is capable of distinguishing between said states.

10. The apparatus of claim 9 adapted for reading data from a three dimensional optical storage medium wherein object planes are located within the medium and the detecting means is capable of producing a signal dependent on the state of the elements.



Application No: GB 9919497.9
Claims searched: 1 to 10

Examiner: Donal Grace
Date of search: 28 February 2000

Patents Act 1977
Search Report under Section 17

Databases searched:

UK Patent Office collections, including GB, EP, WO & US patent specifications, in:
UK Cl (Ed.R): G2J (J33X) G5R (RLF1, RLF2, RLFX)
Int Cl (Ed.7): G02B 5/18, 27/42 G11B 7/125, 7/135, 7/14
Other: Online: WPI; EPODOC; JAPIO

Documents considered to be relevant:

Category	Identity of document and relevant passage	Relevant to claims
A	WO 99/46768 A1 (GREENAWAY et al)	1
X E	WO 99/42994 A1 (KENWOOD) see page 15 line 6 to page 18 line 7	1, 9 and 10 at least

X	Document indicating lack of novelty or inventive step	A	Document indicating technological background and/or state of the art.
Y	Document indicating lack of inventive step if combined with one or more other documents of same category.	P	Document published on or after the declared priority date but before the filing date of this invention.
&	Member of the same patent family	E	Patent document published on or after, but with priority date earlier than, the filing date of this application.