



INTERNATIONAL APPLICATION PUBLISHED UNDER THE PATENT COOPERATION TREATY (PCT)

<p>(51) International Patent Classification ⁷ : A61B 5/145</p>	<p>A1</p>	<p>(11) International Publication Number: WO 00/40150</p> <p>(43) International Publication Date: 13 July 2000 (13.07.00)</p>															
<p>(21) International Application Number: PCT/JP99/07325</p> <p>(22) International Filing Date: 27 December 1999 (27.12.99)</p> <p>(30) Priority Data:</p> <table border="0"> <tr> <td>11/215</td> <td>4 January 1999 (04.01.99)</td> <td>JP</td> </tr> <tr> <td>11/63905</td> <td>10 March 1999 (10.03.99)</td> <td>JP</td> </tr> <tr> <td>11/193754</td> <td>7 July 1999 (07.07.99)</td> <td>JP</td> </tr> <tr> <td>11/196829</td> <td>12 July 1999 (12.07.99)</td> <td>JP</td> </tr> <tr> <td>11/322465</td> <td>12 November 1999 (12.11.99)</td> <td>JP</td> </tr> </table> <p>(71) Applicant: TERUMO KABUSHIKI KAISHA [JP/JP]; 44-1, Hatagaya 2-chome, Shibuya-ku, Tokyo 151-0072 (JP).</p> <p>(72) Inventors: NISHIKAWA, Hisao; 3-13-9-103, Syonandai, Fujisawa-shi, Kanagawa 252-0804 (JP). SONODA, Kouichi; 1-11-24-21, Yurigaoka, Ninomiya-cho, Naka-gun, Kanagawa 259-0133 (JP). TAKINAMI, Masao; 340-5, Ojiri, Hadano-shi, Kanagawa 257-0011 (JP). MORIKAWA, Naoki; 4354-15, Nishiyahata, Ryuuou-cho, Nakakoma-gun, Yamanashi 400-0117 (JP).</p> <p>(74) Agents: WATANABE, Mochitoshi et al.; Hayakawa-Tonakai Building, 3rd Floor, 12-5, Iwamoto-cho 2-chome, Chiyoda-ku, Tokyo 101-0032 (JP).</p>		11/215	4 January 1999 (04.01.99)	JP	11/63905	10 March 1999 (10.03.99)	JP	11/193754	7 July 1999 (07.07.99)	JP	11/196829	12 July 1999 (12.07.99)	JP	11/322465	12 November 1999 (12.11.99)	JP	<p>(81) Designated States: CN, KR, SG, European patent (AT, BE, CH, CY, DE, DK, ES, FI, FR, GB, GR, IE, IT, LU, MC, NL, PT, SE).</p> <p>Published <i>With international search report.</i></p>
11/215	4 January 1999 (04.01.99)	JP															
11/63905	10 March 1999 (10.03.99)	JP															
11/193754	7 July 1999 (07.07.99)	JP															
11/196829	12 July 1999 (12.07.99)	JP															
11/322465	12 November 1999 (12.11.99)	JP															

(54) Title: ASSEMBLY HAVING LANCET AND MEANS FOR COLLECTING AND DETECTING BODY FLUID

(57) Abstract

An assembly (1) to be detachably mounted on a body fluid-monitoring system (9) is provided. The assembly has a lancet (4) and a means for collecting (33, 34) and detecting (32) a body fluid. The lancet has a puncture needle (41) which is maintained in sterilized conditions until its use. The assembly comprises a first housing (2) having a sleeve (21) which movably accommodates the lancet (4) in its interior, and a second housing (3) having the body fluid detection means (32). The first housing (2) and the second housing (3) share an opening (22). The lancet (4) is sterilized before the assembly. The body fluid-collecting and detecting section has a body fluid guide (34a, 34b) on the periphery of the inlet.

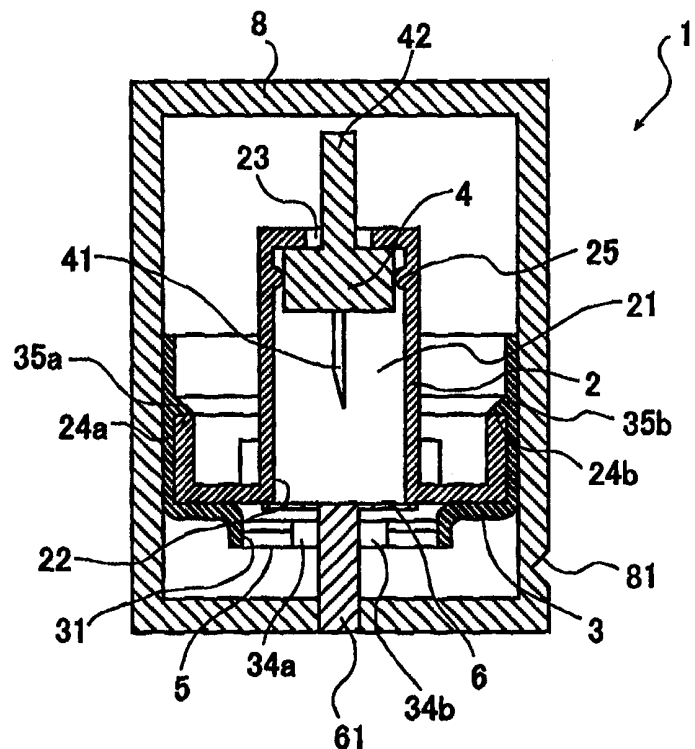

FOR THE PURPOSES OF INFORMATION ONLY

Codes used to identify States party to the PCT on the front pages of pamphlets publishing international applications under the PCT.

AL	Albania	ES	Spain	LS	Lesotho	SI	Slovenia
AM	Armenia	FI	Finland	LT	Lithuania	SK	Slovakia
AT	Austria	FR	France	LU	Luxembourg	SN	Senegal
AU	Australia	GA	Gabon	LV	Latvia	SZ	Swaziland
AZ	Azerbaijan	GB	United Kingdom	MC	Monaco	TD	Chad
BA	Bosnia and Herzegovina	GE	Georgia	MD	Republic of Moldova	TG	Togo
BB	Barbados	GH	Ghana	MG	Madagascar	TJ	Tajikistan
BE	Belgium	GN	Guinea	MK	The former Yugoslav Republic of Macedonia	TM	Turkmenistan
BF	Burkina Faso	GR	Greece	ML	Mali	TR	Turkey
BG	Bulgaria	HU	Hungary	MN	Mongolia	TT	Trinidad and Tobago
BJ	Benin	IE	Ireland	MR	Mauritania	UA	Ukraine
BR	Brazil	IL	Israel	MW	Malawi	UG	Uganda
BY	Belarus	IS	Iceland	MX	Mexico	US	United States of America
CA	Canada	IT	Italy	NE	Niger	UZ	Uzbekistan
CF	Central African Republic	JP	Japan	NL	Netherlands	VN	Viet Nam
CG	Congo	KE	Kenya	NO	Norway	YU	Yugoslavia
CH	Switzerland	KG	Kyrgyzstan	NZ	New Zealand	ZW	Zimbabwe
CI	Côte d'Ivoire	KP	Democratic People's Republic of Korea	PL	Poland		
CM	Cameroon	KR	Republic of Korea	PT	Portugal		
CN	China	KZ	Kazakstan	RO	Romania		
CU	Cuba	LC	Saint Lucia	RU	Russian Federation		
CZ	Czech Republic	LI	Liechtenstein	SD	Sudan		
DE	Germany	LK	Sri Lanka	SE	Sweden		
DK	Denmark	LR	Liberia	SG	Singapore		
EE	Estonia						

DESCRIPTION

ASSEMBLY HAVING LANCET AND MEANS FOR COLLECTING AND
DETECTING BODY FLUID

5

Technical Field

This invention relates to an assembly which is detachably mounted to a body fluid-monitoring system for laboratory testing of a body fluid such as blood, wherein the assembly has a lancet and a means for collecting and
10 detecting the body fluid. This invention also relates to a body fluid-collecting and detecting unit for use in such assembly, and a body fluid-monitoring system having such an assembly detachably mounted thereto.

15

Background Art

With the increase in the number of patients suffering from diabetes, self-monitoring of blood glucose wherein the patient can daily monitor his or her blood glucose level has
20 been highly recommended. In view of such situation, various systems wherein a lancet and a glucose meter are integrated have been disclosed for ease of the blood glucose self-monitoring and to enable hygienic measurement. Such systems are disclosed, for example, in JP-A 6-339473, JP-A 9-276235,
25 and USP 4,787,398.

In the system of the type disclosed in JP-A 6-339473, the lancet mechanism and the detection mechanism are separate, and the lancet unit including the puncture needle and the detection unit including the test strip should be separately
30 mounted on the monitoring system, and the operation is cumbersome.

JP-A 9-276235 and USP 4,787,398 proposes a body fluid-monitoring system wherein the lancet mechanism and the detection mechanism are integrally assembled.

The blood glucose meter disclosed in JP-A 9-276235
5 comprises a lancet, a tourniquet for compressing the finger, and a means for detecting the target component in the blood and displaying the results, accommodated in a housing. In this glucose meter, collection of the required amount of the blood is enabled by the use of the tourniquet, and as a
10 consequence, this system is associated with the risk of infection by the blood that adheres to the tourniquet when the finger is pulled out through the tourniquet after the blood collection.

JP-A 9-276235 also discloses use of a disposable
15 cartridge wherein a puncture needle and an electrode coated with an enzyme ink are accommodated. JP-A 9-276235, however, is silent about sterilization of the puncture needle before its use. In JP-A 9-276235, the puncture needle and the electrode coated with the enzyme ink are arranged adjacent to
20 each other, and sterilization of the puncture needle should be quite difficult once the cartridge is accommodated in the cartridge. Assembly of the cartridge after sterilizing the puncture needle, on the other hand, is quite nonproductive since a clean room is required for such operation.

25 USP 4,787,398 proposes a monitoring system wherein a unit provided with a lancet having a puncture needle and a detection means having a test strip can be mounted on the main body of the monitoring system, and wherein the operation is thereby simplified. This system also suffers from the
30 difficulty of sterilization as in the case of JP-A 9-276235, and sterilization of the unit before its use is associated with the risk of denaturing of the reagents immobilized on

the test strip. Therefore, it has been difficult to deliver a product wherein sterilization of the puncture needle is maintained until the use of the product.

The self-monitoring of blood glucose is normally conducted by using a lancet and a glucose meter. To be more specific, the lancet having a puncture needle or a blade on its tip is first used to collect the blood of required volume by pricking the finger tip with the lancet and milking or squeezing the skin around the puncture site to ensure the formation of the blood droplet of required amount. The lancet is held by the hand which is not bleeding in the step of blood collection. The lancet is then replaced with the glucose meter for the measurement of the blood glucose. Such change of the device should be conducted while the blood is flowing out from the punctured site, and this procedure is associated not only with inconvenience of the operation but also with unfavorable sanitary conditions.

Use of a body fluid-collecting cartridge is also proposed including the type wherein the blood is dropped on the test strip in the cartridge, the type wherein the blood is guided to the test strip by capillary action, and the type wherein the blood is once introduced into a reservoir defined in the cartridge and then guided to the test strip by capillary action. See, for example, JP-A 4-264246, JP-A 7-55801 and JP-A 247946.

The type wherein the blood is dropped on the test strip in the cartridge is associated with the problem of inconsistent measurement value since the time interval between the blood collection and mounting of the cartridge is not constant.

The type wherein the blood is guided to the test strip by capillary action is also associated with various demerits.

For the purpose of reducing the burden of the patient, the interior volume of the capillary is minimized to reduce the amount of the blood remaining in the capillary after the detection. Such reduction in the volume of the capillary results in the reduced size of the inlet of the capillary, and introduction into the capillary of the blood becomes difficult. In addition, when the area surrounding the capillary inlet erroneously becomes in contact with the blood, sucking of the blood into the capillary is impeded. The situation is the same even if a reservoir is provided in the cartridge unless an appropriate guiding structure is provided in the area surrounding the inlet. Moreover, when such reservoir is in the same plane as the main body of the cartridge, there is always some risk of blood leakage from the gap between the finger and the reservoir due to the finger print unless the finger is very tightly pressed against the cartridge, and such blood leakage is likely to result in the blood adhesion to the back surface of the cartridge, and also, increase in the amount of the blood necessary for the measurement. On the other hand, when the blood volume collected by the lancet is insufficient, the blood will never reach the test strip. The measurement is, therefore, unreliable and unsanitary.

In view of such situation, there is a strong demand for a body fluid-collecting cartridge which is capable of reliably sucking the collected body fluid into its interior with no adhesion on the exterior surface, and wherein collection of minimum necessary amount of the body fluid is required.

30

Disclosure of the Invention

An object of the present invention is to provide an assembly which is detachably mounted on a body fluid-monitoring system wherein lancing mechanism and measuring mechanism are assembled in one assembly, and which comprises the lancing section including the puncture needle and the detection section including the test strip.

Another object of the invention is to provide an assembly wherein the lancet is maintained in sterilized conditions until its use while function of the detection section including the test strip is maintained.

A further object of the present invention is to provide a body fluid-collecting and detecting unit for use in such assembly, and a body fluid-monitoring system having such an assembly detachably mounted thereto.

This and other objects of the present invention will be apparent by reading the following description in conjunction with the drawings.

Such objects are attained by the present invention as summarized below in (1) to (26).

(1) An assembly having a lancet and a means for collecting and detecting a body fluid wherein said assembly is to be detachably mounted on a body fluid-monitoring system having a lancing means and said assembly comprises:

a lancet section comprising

a lancet having a puncture needle on its distal end and a connector on its proximal end for connection to said lancing means of the body fluid-monitoring system, and

a first housing having a sleeve which movably accommodates said lancet in its interior, and which has a first opening on its distal end to enable projection of the needle into its exterior and a proximal opening to enable

connection of said connector with said lancing means of the body fluid-monitoring system, and

wherein said lancet before the lancing is secured in said sleeve at a position near its proximal opening
5 capable to gas-tightly seal said sleeve;

a body fluid-collecting and detecting section comprising a body fluid detection means and a second housing having a second opening for introducing the body fluid into said
10 detection means;

a first seal member for sealing said first opening and optionally a second seal member for sealing said proximal
15 opening;

and

wherein said first housing is gas-tightly sealed with both
20 said first seal member for sealing said first opening and said lancet or said optional second seal member for sealing said proximal opening; and

said first housing and said second housing are fixedly integrated each other such that said first opening of said
25 first housing and said second opening of said second housing together define a distal opening to enable the projection of said puncture needle to the exterior of said assembly, and the one-piece assembly having the lancet section and the body fluid-collecting and detecting section is thereby constituted.

(2) An assembly according to the above (1) produced by
30 sterilizing said lancet section having said puncture needle accommodated in said first housing with said first opening and said proximal opening sealed; and assembling the sterilized lancet section with said body fluid-collecting and detecting section in one piece unit.

(3) An assembly according to the above (1) wherein the entire assembly after assembling is covered with a protective shield.

5 (4) An assembly according to the above (2) wherein the entire assembly after assembling is covered with a protective shield.

(5) An assembly according to the above (3) or (4) wherein said first seal member is connected to said protective shield and said first seal member is removed from
10 said first opening simultaneously with the removal of said protective shield.

(6) An assembly according to any one of the above (2) to (5) wherein said puncture needle remains sterilized until said first seal member is removed from said first opening.

15 (7) An assembly according to any one of the above (1) to (6) wherein said first housing has a means for preventing detachment of said lancet after its use.

(8) An assembly according to the above (7) wherein said detachment-preventing means also serves the function of
20 sealing said proximal opening of said sleeve.

(9) An assembly according to any one of the above (1) to (8) wherein said second housing is defined with a flow path for guiding the body fluid from said distal opening to said body fluid detection means by capillary action, and an inlet
25 port for guiding said body fluid into said flow path.

An assembly according to any one of the above (1) to (9) wherein said flow path may have an air vent near said body fluid detection means.

(10) An assembly according to the above (9) wherein said
30 flow path in the second housing comprises a plurality of flow path sections between which corners are defined at an angle, and a projection protruding into the flow path is provided on

each corner so that the tip of the projection contacts with meniscus of the body fluid formed at the corner.

(11) An assembly according to the above (9) or (10) wherein said inlet port has a body fluid guide formed along
5 its periphery.

(12) An assembly according to the above (11) wherein said body fluid guide comprises two or more guide members and said guide members are projections formed on the periphery of said inlet port.

10 (13) An assembly according to the above (11) or (12) wherein said body fluid guide is located inside of said second opening.

(14) An assembly according to any one of the above (11) to (13) wherein said body fluid guide has a constitution
15 comprising two side members and a lower plate member.

(15) An assembly according to the above (14) wherein said lower plate member has a downwardly extending projection on a distal section thereof.

(16) An assembly according to the above (14) or (15)
20 wherein said body fluid guide members are designed such that the width between said side members increases from the side of said inlet to the side of distal end, and surface tension of said body fluid is lower in the interior space enclosed with said fluid guide members than in the interior of said
25 flow path, and the distal ends of said side members are mounted at an angle less than 90° to the bottom face of said second opening.

(17) An assembly according to any one of the above (1) to (16) wherein said second housing has a sleeve in its
30 interior to fittingly receive at least a part of the sleeve of the first housing, and said sleeve of the second housing has an opening in its body; and

detection area of the body fluid detection means is secured to the exterior surface of said sleeve of the second housing.

(18) An assembly according to any one of the above (11) to (17) wherein said puncture needle passes near the tip of said body fluid guide or between side members of said body fluid guide during the puncture.

(19) An assembly having a lancet assembled with a body fluid-collecting and detecting section, wherein said lancet has a puncture needle on its distal end and a connector on its proximal end for connection to the lancing means of the body fluid-monitoring system, and said lancet section has been gas-tightly sealed under sterilized conditions.

(20) A body fluid-collecting and detecting unit comprising:
an inlet port for the body fluid;
a test strip which enables measurement of the target component in the body fluid;
a flow path for guiding the body fluid from said inlet port to said test strip by capillary action; and
a body fluid guide formed along the periphery of the inlet port.

(21) A body fluid-collecting and detecting unit according to claim 20 wherein said body fluid guide comprises two or more guide members and said guide members are projections formed on the periphery of said inlet port.

(22) A body fluid-collecting and detecting unit according to the above (20) or (21) wherein said body fluid-collecting and detecting unit is accommodated within a housing having an opening, and said body fluid guide is accommodated inside said opening.

(23) A body fluid-collecting and detecting unit according to any one of the above (20) to (22) wherein said body fluid guide has a constitution comprising two side members and a lower plate member.

5 (24) A body fluid-collecting and detecting unit according to the above (23) wherein said lower plate member has a downwardly extending projection on a distal section thereof.

10 (25) A body fluid-collecting and detecting unit according to the above (23) or (24) wherein said body fluid guide members are designed such that the width between said side members increases from the side of said inlet to the side of distal end, and surface tension of said body fluid is lower in the interior space enclosed with said fluid guide
15 members than in the interior of said flow path, and the distal ends of said side members are mounted at an angle less than 90° to the bottom face of said second opening.

(26) A body fluid-monitoring system comprising a main body of the body fluid-monitoring system and the assembly of
20 any one of the above (1) to (19), wherein said main body includes:

a lancing means having a recess at its distal end,
a means for measuring the target component in the body fluid, and

25 a holder means for detachably holding the assembled housings of the assembly, and

said assembly is held by said holder means, and the connector of said lancet is fitted into said recess formed in the distal end of said lancing means.

30

Brief Description of the Drawings

FIG. 1 is a lateral cross sectional view of the assembly 1 according to first embodiment of the present invention.

FIG. 2 is a lateral cross sectional view similar to FIG. 1 partially showing the first housing 2.

5 FIG. 3 is a plan view of the second housing 3.

FIG. 4 is a cross sectional view taken along lines X-X of the second housing 3 in FIG. 3.

FIG. 5 is a plan view of the test strip holder 136 (without paper) in the second housing 3.

10 FIG. 6 is a lateral cross sectional view of the assembly 1 according to the first embodiment of the present invention showing how it is used.

FIG. 7 is a lateral cross sectional view of the assembly 101 according to the second embodiment of the present invention.

FIG. 8 is a lateral cross sectional view similar to FIG. 1 partially showing the first housing 102.

FIG. 9 is a front view of the second housing 103.

FIG. 10 is a top view of the second housing 103.

20 FIG. 11 is a front view of the test strip holder 36 (without paper) in the second housing 103.

FIG. 12 is a cross sectional view taken along lines Y-Y of the second housing 103 in FIG. 10.

25 FIG. 13 is a cross sectional view of another embodiment of the air vent structure corresponding to FIG. 4.

FIG. 14 is a plan view of the body fluid guide according to an embodiment of the invention.

FIG. 15 is a perspective view of the body fluid guide according to the embodiment of FIG. 14.

30 FIG. 16 is a plan view of the body fluid guide according to another embodiment.

FIG. 17 is a plan view of the body fluid guide according to a further embodiment.

FIG. 18 is a cross sectional view of the body fluid guide according to a further embodiment.

5 FIG. 19 is a plan view showing an embodiment wherein the body fluid guide 34 covers three directions (i.e. downward, left and right directions) of the body fluid inlet 33a.

FIG. 20 is a cross sectional view taken along lines Z-Z in FIG. 19.

10 FIG. 21 is a schematic view for explaining the operation of the assembly 1 according to the present invention.

FIG. 22 is a schematic view for explaining the operation of the assembly 1 according to the present invention.

15 FIG. 23 is a schematic view for explaining the operation of the assembly 1 according to the present invention.

Best Mode for Carrying the Invention

This invention provides an assembly to be detachably mounted on a body fluid-monitoring system, and the assembly
20 is provided with a lancet and a means for collecting and detecting a body fluid.

The assembly comprises a lancet section, a body fluid-collecting and detecting section, and a first seal member.

The lancet section comprises a lancet and a first
25 housing. The lancet has a puncture needle on its distal end a connector on its proximal end for connection to a lancing means in the body fluid-monitoring system. The first housing has a sleeve which movably accommodates the lancet in its interior. The sleeve has a first opening on its distal end
30 to extend the needle to the exterior of the sleeve and a proximal opening to enable the connector to connect with the lancing means in the body fluid-monitoring system. The

lancet before the lancing is secured in the sleeve at a position near its proximal opening to gas-tightly seal the sleeve. The body fluid-collecting and detecting section comprises a body fluid detection means and a second housing
5 having a second opening for introducing the body fluid into said detection means. The first seal member seals the first opening.

In the assembly of the present invention, the first housing and the second housing are fixedly secured to each
10 other such that the first opening of the first housing and the second opening of the second housing define a distal opening to enable the puncture needle to extend beyond the opening, and the one-piece assembly having the lancet section and the body fluid-collecting and detecting section is
15 thereby constituted.

As described above, in the assembly of the present invention, the lancet unit in the first housing and the body fluid-collecting and detecting unit in the second housing are joined in one unit to share their opening. The puncture
20 needle of such lancet unit can be sterilized in the first housing with the first opening and the proximal opening closed.

Accordingly, the present invention also provides a sterilized lancet unit to be assembled with the body fluid-collecting and detecting unit, and a body fluid-collecting
25 and detecting unit to be assembled with the sterilized lancet unit.

Next, the first preferred embodiment of the present invention is described in detail by referring to the drawings
30 (mainly FIGS.1 to 6). It should be noted that, in the drawings, the same reference numeral indicates equivalent

members, and description may be omitted for such equivalent members.

FIG. 1 is a lateral cross sectional view of an assembly 1 according to the first embodiment of the present invention.

5 The assembly 1 comprises a first housing 2 accommodating the lancet 4 and a housing 3 accommodating the body fluid-collecting and detecting means.

10 FIG. 2 is a cross sectional view of the lancet section of FIG. 1. The first housing 2 has a sleeve 21 in which the lancet 4 is movably accommodated. The sleeve 21 has a first opening 22 at its distal end and a proximal opening 23 at its proximal end.

15 FIG. 3 is a plan view of the body fluid-collecting and detecting section, and this section comprises detection means 32 and the housing 3 having a second opening 31 formed therewith to allow introduction of the body fluid to the detection means 32.

FIG. 4 is a cross sectional view taken along lines X-X of the second housing 3 in FIG. 3.

20 The first housing 2 and the second housing 3 are fixedly secured to each other to constitute the assembly 1 such that the first opening 22 and the second opening 31 surrounding the first opening 22 together form the distal opening 5.

25 FIG. 6 is a view showing the assembly 1 mounted on a body fluid-monitoring system 9.

30 The second housing 3 is not limited for its shape as long as it has the detection means 32 defined therein; it shares its opening 31 with the first housing 2 to form the distal opening 5; and it is capable of holding the first housing 2 in its interior.

In the first embodiment, the detection area 32 is formed at a particular angle in relation to the axial direction of the member holding the sleeve 21 of the housing 2.

The first housing 2 has the sleeve 21 in its interior, and the lancet 4 is movably accommodated in the sleeve 21.

The sleeve 21 is not limited for its shape, and it may be either a cylinder or a rectangular tube. For structural easiness of production, the sleeve 21 is preferably a cylinder.

The lancet 4 has a puncture needle 41 at the distal end, and a connector 42 at the proximal end for connection to a lancing means 91 in the body fluid-monitoring system 9. The shape of the connector 42 is not limited to the convex type as shown in the drawings, and the connector 42 of any shape may be employed as long as it corresponds to the shape of the lancing means 91. In addition, the connector 42 may not necessarily extend beyond the proximal opening 23.

The lancet 4 is secured at a position near the proximal end of the sleeve 21, namely, at a position such that the puncture needle 41 does not extend beyond the first opening 22. The lancet 4 is secured to the sleeve 21 at a firmness such that the puncture needle 41 does not extend beyond the first opening 22 before the use, such that that the operation of connecting the connector 42 with the lancing means 91 can be accomplished, and such that the connector 42 is released from the secured position when the lancet 4 is urged by the pushing force of the lancing means 91 upon its use. The means for securing the lancet 4 is not limited, and the lancet 4 may be secured by providing an engagement means on the interior surface of the sleeve 21 and/or on the exterior surface of the lancet 4; by utilizing the friction between the interior surface of the sleeve 21 and the exterior

surface of the lancet 4; or by weakly bonding the contact surfaces with an adhesive or by fusion.

The lancet securing means may also serve the function of the mechanism for preventing detachment of the lancet 4 as well as the mechanism of sealing the proximal opening 22. As will be described later, the lancet detachment-preventing mechanism ensures safe disposal of the assembly after its use with no risk of pricking the skin with the puncture needle 41 which has accidentally extended into the exterior of the sleeve. To be more specific, upon detachment of the assembly 1 from the main body of the body fluid-monitoring system 9, the lancet 4 is pulled back in the direction toward its proximal end to be secured in the lancet securing means since the connector 42 is fittingly secured in the recess 92 at the distal end of the lancing means 91. The seal mechanism of the proximal opening 22 prevents interior of the sleeve from contamination by bacteria and other microorganisms.

In such a case, the lancet 4 before its use is secured at a position near the proximal opening 23 such that the proximal opening 23 is sealed by the lancet 4. Such sealing of the proximal opening 23 may be accomplished by the same method as described for the securing of the lancet 4, and in a typical embodiment, the lancet 4 is fitted into the space defined by a ridge 25 extending in circumferential direction on the interior surface of the sleeve 21 as shown in FIGS. 1 and 2. Alternatively, the interior of the sleeve 21 may be narrowed near its proximal end and the lancet 4 may be fittingly secured in such narrow proximal end of the sleeve 21, or the lancet 4 may be fitted into the space between the protrusions provided in some part of the interior surface of the sleeve 21 to facilitate gas-tight contact between the

interior surface of the sleeve 21 near its proximal end and the exterior surface of the lancet 4 near its proximal end.

When the assembly 1 is detached from the body fluid-monitoring system 9, the lancet will be pulled back toward the proximal end of the first housing 2 since the lancet 4 is
5 connected to the lancing means 91 of the body fluid-monitoring system 9 through the connector 42. When the lancet 4 has been fittingly secured to the securing/sealing means as described above such as the ridge 25 extending in
10 circumferential direction, the connector 42 becomes detached from the lancing means 91, and the assembly 1 will be finally detached from the body fluid-monitoring system 9. In the course of the detachment, the puncture needle 41 becomes
15 firmly secured to the sleeve 21, and the puncture needle 41 is reliably prevented from extending beyond the second opening 31. Accidental prickling of the skin by the puncture needle 41 after its use is thereby prevented.

As described above, the gas-tight sealing of the sleeve 21 at the proximal opening 23 is preferably realized by the
20 gas-tight sealing by the lancet 4. Alternatively, the proximal opening 23 may be sealed by a second seal member (not shown) like the first seal member 6 as will be described later. In such a case, the proximal opening 23 may or may not be sealed by the lancet 4.

25 When the proximal opening 23 of the sleeve 21 is sealed by the lancet 4, the lancet 4 must fit in the sleeve 21 near its proximal end, and therefore, the lancet 4 should have a cross section that corresponds to the cross section of the sleeve 21. In principle, the lancet 4 may be formed from the
30 same material as the first housing 2 or the second housing 3 as will be described below, and the material used for the lancet 4 may preferably have some degree of flexibility.

Exemplary materials used for the first housing 2 include ABS, polyethylene, polypropylene, polystyrene, polyvinyl chloride, polyvinylidene chloride resin, polyphenylene oxide, thermoplastic polyurethane, polymethylene methacrylate, polyoxyethylene, fluororesin, polycarbonate, polyamide, acetal resin, acryl resin, polyethylene phthalate and other thermoplastic resins used in the injection molding; and phenol resin, epoxy resin, silicone resin, unsaturated polyester resin and other thermosetting resins.

10 The interior of the sleeve 21 is kept in gas-tightly sealed conditions by sealing the first opening 22 and the proximal opening 23. The first opening 22 is sealed by the first seal member 6. As shown in the drawings, the first seal member 6 is in the form of a film secured to the periphery of the first opening 22 with an adhesive or by fusion.

15 Although the first seal member 6 is preferably in the form of a film for ease of bonding by adhesion or fusion as well as peeling, the first seal member 6 may also be in the form of a lid or a plug as shown in FIG. 8.

20 The interior of the first housing 2 is maintained in sterilized condition by sterilizing the sleeve 21 after enclosing the lancet 4 in its interior and sealing the proximal opening 23; or enclosing the sterilized lancet 4 in the interior of the sterilized sleeve 21 and maintaining the interior of the sleeve 21 in sealed conditions until its use. Of these procedures, sterilization of the sleeve 21 after enclosing the lancet 4 and sealing the proximal opening 23 is advantageous for ease of the operation.

30 The sterilization may be conducted by any method, for example, by sterilization with EOG, γ ray, electron beam, or the like.

As described above, the first housing 2 is assembled with the second housing 3 to produce the assembly 1 after ensuring that the sterility of the interior of the sleeve 21 will be maintained until its use.

5 Next, the body fluid-collecting and detecting section is described by mainly referring to FIGS. 3 to 5.

The body fluid-collecting and detecting section accommodates the body fluid detection means 32 in its interior, and comprises the second housing 3 having a second opening 31 for introducing the body fluid into the detection means 32.

In the present embodiment, the second opening 31 is formed in the bottom surface 3a of the second housing 3 at an eccentric position. The wall of the housing 3 on the side of the second inlet 31 has a shoulder 3b for holding at least a part of the first housing 2. A test strip housing 32a is provided on the bottom surface 3a of the housing 3 on the side different from the second opening 31.

In FIGS. 3 and 4, a test strip is used in the body fluid detection means 32. The test strip (body fluid detection means) 32 is secured in the test strip holder 36 formed as a recess in the test strip housing 32a. A body fluid inlet 33a and a flow path 33 for guiding the body fluid from the body fluid inlet 33a to the test strip 32 are formed between the test strip housing 32a and the wall of the second housing 3. It should be noted that the body fluid detection means is not limited to the test strip, and any medium suitable as a body fluid detection means of the body fluid monitoring system 9 may be used.

30 The material used for the second housing 3 may be the same as the one described for the first housing 2. When the body fluid-measuring means 93 in the body fluid monitoring

system 9 is an optical means which conducts the measurement by detecting the color reaction on the test strip, the housing 3 may preferably comprise a non-transparent material to thereby shut out the influence of exterior light and increase the measurement accuracy. For ease of confirming the movement of the body fluid in the flow path 33, the second housing 3 may comprise a colored, translucent resin.

The cross section and the length of the flow path 33 may vary in accordance with the amount of the body fluid required for the measurement. The flow path 33, however, is preferably designed such that the volume of the body fluid remaining in the flow path 33 is minimized. The flow path 33 may typically comprise a groove having a semi-circular, V-shaped, or rectangular cross section, and for reducing the amount of the body fluid remaining in the flow path 33, the flow path 33 may preferably comprise a shallow groove having a rectangular cross section. The depth is preferably in the range of about 0.05 to about 0.5 mm, and the width is preferably in the range of from about 0.5 to about 3 mm. The flow path 33 may preferably have a short length although the length may depend on the position of the body fluid-measuring means 93 of the body fluid monitoring system 9. The suitable length, however, is in the range of from about 5 mm to about 15 mm.

When the body fluid is introduced along the flow path 33 from the body fluid inlet 33a to the test strip 32 in a closed system, the capillary action may stop before the reaching of the body fluid to the test strip 32. In view of such situation, provision of an air vent is necessary, and the air vent is provided in the test strip holder 36.

A preferable structure of the air vent is shown in the plan view of the test strip holder 36 in FIG. 5. In this

structure, the test strip supports 38 and the air vent 37 at the end 33b of the flow path 33 on the side of the test strip 32 are formed so that the test strip can be secured as shown in FIG. 4 wherein a gap 39a is defined between the periphery of the test strip 32 and the periphery of the test strip holder 36, and a gap 39b is defined between the lower surface of the test strip 32 and the test strip holder 36. The test strip 32 is supported between the test strip supports 38 and the end 33b of the flow path 33 on the side of the test strip 32. The gap 39b between the lower surface of the test strip 32 and the test strip holder 36 is preferably about 0.01 to about 0.3 mm.

The air vent structure is not limited to the one as described above, and the test strip 32 may be placed at some midpoint in and on one side of the flow path 33 so that an air vent 39a is formed at the end of the flow path 33 as shown in FIG. 13.

The test strip housing 32a which defines the flow path 33 may be formed from the same material as the second housing 3. The test strip housing 32a, however, is preferably formed from a material of high hydrophilicity such as acryl resin. When the test strip housing 32a is formed from a material which is not sufficiently hydrophilic, the surface of the second housing 3 may be treated to impart the surface with the hydrophilicity to improve the sucking of the body fluid into the flow path 33. Typical such treatments include physical activations such as ozone treatment, plasma treatment, glow discharge, corona discharge, UV irradiation; coating of a surfactant, water soluble silicone, hydroxypropyl cellulose, polyethylene glycol, polypropylene glycol, or the like.

The flow path 33 may be may be formed by various procedure. When the flow path 33 is defined by the test strip housing 32a and the second housing 3, the flow path 33 may be formed by injection molding the test strip housing 32a and the second housing 3 in one piece. Alternatively, the flow path 33 may be formed in the second housing 3 by cutting or pressing the housing 3, or by fixedly securing a tube or a groove-shaped member in the housing 3.

The body fluid detecting means or the test strip 32 is not limited to any particular type, and any material matching with the body fluid-measuring means 93 of the body fluid monitoring system 9 may be used. For example, when the body fluid-measuring means 93 is an optical measurement means which detects color reaction in the test strip as in the case of the measurement of glucose in blood, the test strip may be impregnated with glucose oxidase, peroxidase, and a chromogenic agent followed by drying. The test strip 32 is preferably a porous membrane in the form of a nonwoven, a woven fabric, a stretched sheet, or the like prepared from a material such as a polyester, a polyamide, a polyolefin, a polysulfone, a cellulose, or the like. Since the test strip 32 is impregnated with various reagents as well as the body fluid, the test strip 32 is preferably the one formed from a hydrophilic material or the one which has been treated to impart hydrophilicity. The test strip 32 may be either a mono-layer sheet or a multi-layer sheet.

The body fluid inlet 33a is preferably formed with a body fluid guide 34 on its periphery. The body fluid guide 34 has the function of guiding the body fluid which becomes in contact with the guide 34 to the body fluid inlet 33a.

Provision of such guide 34 enables efficient introduction of the body fluid into the flow path 33.

Accordingly, the present invention also provides a body fluid-collecting and detecting unit comprising the body fluid inlet 33a, the test strip 32 which enables the measurement of the target component in the body fluid, the path 33 which sucks the body fluid from the body fluid inlet 33a to the test strip 32, and a body fluid guide 34 provided on the periphery of the body fluid inlet 33a. Also provided in the present invention is a body fluid-collecting and detecting unit wherein the components as described above are accommodated within the housing 3.

The body fluid guide 34 may be formed from the same material as the second housing 3 or the test strip housing 32a, and the body fluid guide 34 is preferably imparted with hydrophilicity as in the case of the flow path 33.

The body fluid guide 34 may be located inside of the second opening 31 of the second housing 3.

When the body fluid guide 34 has an inappropriate shape, the excess body fluid which was not sucked from the body fluid inlet 33a will spread around the second opening 31 to invite sanitary problem. The body fluid guide 34 of an inappropriate shape will also result in an insufficient sucking of the body fluid into the flow path 33, and the amount of body fluid required for the measurement will be increased to result in the increased burden of the patient. Accordingly, the body fluid guide 34 should have a structure which is capable of rapidly guiding the body fluid to the body fluid inlet 33a, and which is capable of retaining a large amount of the body fluid to prevent the spreading or flowing out of the body fluid to surrounding areas. A typical structure of the body fluid guide 34 is two or more projections formed in the periphery of the body fluid inlet 33a.

An embodiment of the body fluid guide is shown in plan view (FIG. 14) and in perspective view (FIG. 15). The body fluid guide of this embodiment comprises guide members 34a and 34b in the form of rails provided on opposite ends and on the periphery of the body fluid inlet 33a.

The volume of the space defined by the body fluid guide 34 may vary by the volume of the body fluid collected, namely, by the diameter of the body fluid collected. The width of the guide 34 is at most the diameter of the body fluid collected. For example, when the body fluid in an amount of about 4 μ l is collected as in the case of blood glucose monitoring, the body fluid emerging on the skin surface is about 3 mm in diameter, and in such a case, the guide 34 may preferably have a width of about 1 mm to about 3 mm, a height of about 0.5 mm to about 3 mm, and a length of about 1 mm to about 3 mm. The height of the guide 34a and 34b is preferably equivalent to the maximum diameter of the body fluid inlet 33a.

The shape of the guide members 34a and 34b is not limited to the one shown in FIG. 14 wherein opposed interior surfaces are arranged parallel to each other. The guide members 34a and 34b may also be designed as shown in FIG. 16 wherein the space defined by the opposed interior surfaces widen toward the center of the second opening 31. In other word, the body fluid guide members are designed such that the width between said side members increases from the side of said inlet to the side of distal end.

In addition, the guide members 34a and 34b may be arranged as shown in FIG. 17 such that the diameter defined by the opposed interior surfaces of the guide members 34a and 34b at the connection with the body fluid inlet 33a is smaller than the diameter of the body fluid inlet 33a. When

the guide members 34a and 34b are designed such that the space defined by the opposed interior surfaces widen toward the center of the body fluid droplet the body fluid is smoothly fed from the skin surface into the flow path 33 since surface tension of the body fluid in the flow guide 34 is smaller than the surface tension in the flow path 33 and all the body fluid in the guide 34 will be conveyed to the body fluid inlet 33a and then to the flow path 33. As a consequence, there is no need to take the dead volume in the guide 34 into account.

The body fluid guide 34 is not limited to the embodiments comprising two guide members 34a and 34b as described above, and may comprise three or four members wherein the body fluid guide 34 covers all four directions (right, left, upward and downward directions) or three directions (right, left and downward directions) of the body fluid inlet 33a. The body fluid guide 34 may also comprise continuous members extending in circumferential direction, a semicircumferential member, a dome-shaped member, or the like.

The bottom surface of the body fluid guide 34 and the bottom surface of the second housing 3 may not necessarily define the same plane. FIG. 18 is a cross sectional view of the embodiment corresponding to the embodiment shown in FIG. 4. In this embodiment, the bottom surface of the body fluid guide 34 is beyond the bottom surface of the second housing 3.

In the preferred embodiment, the bottom surface of the body fluid guide 34 is higher than the bottom surface of the second housing 3 (the second opening 31), so that the bottom surface of the body fluid guide 34 can contact with the top surface of bulged skin when the monitoring system 9 was on the skin. In another embodiment, the bottom surface of the body fluid guide 34 may be beyond the bottom surface of the

second housing 3 not to contact with the top surface of bulged skin, but to contact only with the body fluid droplet. The suitable height of bottom surface of the body fluid guide 34 from the bottom surface of the second housing 3 is
5 in the range of from about 0.1 mm to about 5 mm, preferably from about 0.5 mm to about 1.5 mm.

FIG. 19 is a plan view showing an embodiment of the body fluid inlet 34 which comprises two guide members 34a and 34b and a lower plate member 34c covering three directions (right,
10 left and downward directions) of the body fluid inlet 33a. FIG. 20 is the cross sectional view taken along lines Z-Z of FIG. 19. In the preferred embodiment, the structure including the lower plate member 34c as shown in the figures is enable to prevent the air from ingressing into the body
15 fluid, even if the air flow may slightly occur through a gap space between the bottom surface of the opening 31 and skin surface when the suction means within the body fluid-monitoring system 9 was applied. The distal ends of the side
20 guide members 34a and 34b may be mounted at an angle less than 90° to the bottom surface of said second housing 3. Furthermore, the structure including the projection 34d on the lower side of the distal end of the guide 34, especially on the lower plate member 34c, can limit the volume of the
25 body fluid to the volume within the above gap space introduced by capillary action.

When the body fluid is collected by the system as described above, the puncture needle 41 passes near the tip of the body fluid guide 34 or between said body fluid guide members before puncturing the skin. When the skin is
30 punctured with the puncture needle 41 and the body fluid droplet of required volume is formed, the droplet contacts the body fluid guide 34. The body fluid is then guided into

the flow path 33, and to the test strip 32. Preferably, the distance between the course of the puncture needle 41 and the tip of the body fluid guide 4 is about 3 mm at most, and more preferably, up to about 1 mm in view of the volume of the body fluid required for the measurement. When the body fluid guide 34 is of the type comprising the guide members 34a and 34b as shown in the figures, the puncture needle 41 may pass between the guide members 34a and 34b.

The bottom surface 3a of the second housing 3 should play the role of guiding the second opening 31 forming the distal opening 5 to the site to be lanced (for example, on the finger tip or belly). For such purpose, the surface 3a is preferably tapered at an angle α from the second opening 31. Since the bottom surface 3a is tapered as described above, the part in contact with the skin will be only the distal opening 5 and not all the areas surrounding the distal opening 5. As a consequence, the user can feel the position of the distal opening 5, and identify the lancing site on the skin by the feeling. The tapering angle α is preferably at least 10 degrees. The embodiment shown in FIG. 6 has the tapering angle α in the range of 10 to 45 degrees. Also encompassed in the invention is an embodiment wherein the bottom surface 3a is not tapered at an angle α , and instead, the second opening 31 protrudes from the main body of the second housing 3.

It should be noted that, when the bottom surface 3a of the second housing 3 is tapered at an angle α , the test strip housing 32a is also tapered at the same angle in relation to the body fluid guide 34.

The method for fixedly securing the first housing 2 with the second housing 3 is not particularly limited. In an

embodiment, the first housing 2 is secured to the second housing 3 so that the sleeve 21 of the first housing 2 rests on the shoulder 3b of the second housing 3, and the engagement means 24a and 24b of the first housing 2 is
5 engaged to the engagement means 35a and 35b of the second housing 3. Alternatively, the first housing 2 and the second housing 3 are secured by bonding the contact surfaces with an adhesive or by fusion. Such structure enables the user to mount the first housing 2 and the second housing 3 at once as
10 an assembly 1 and eliminates the user from the need of separately mounting the first housing 2 and the second housing 3 to the body fluid-monitoring system 9 (see FIG. 6). This in turn means that the user can also remove the first housing 2 and the second housing 3 at once as an assembly 1.

15 Alternatively, the first housing 2 may be pushed and fitted into the second housing 3 as shown in FIG. 7.

It should be noted that, in the embodiment as described above, the test strip housing 32a is formed on the bottom surface 3a. When the second housing 3 has a sleeve which
20 fixedly receive the first housing 2 in its interior, the space required for the second housing 3 will be reduced. Such embodiment will be described later as the second embodiment.

The assembly 1 is preferably sealed in a protective
25 shield 8 after its assembly, namely, after assembling to form the distal opening 5 the first housing 2 having the sealed sleeve 21 and the sterilized puncture needle 41 enclosed therein and the second housing 3 having the body fluid-
30 detecting means. The structure of the protective shield 8 is not limited as long as the assembly 1 of particular embodiment can be sealed in its interior. The embodiment of the protective shield 8 shown in the drawings is the one in

the form of a sheet, and the protective shield 8 of this embodiment can be removed immediately before the use by tearing the sheet from the notch 81. The first seal member 6 may be provided with a connector 61 and the connector 61 may be connected to a part of the interior of the protective shield 8, and in such a case, the first seal member 6 may be simultaneously removed from the first opening 22 upon removal of the protective shield 8. Similarly, when the second seal member (not shown) is present, the second seal member may also be connected to the protective shield 8 in its interior, and in such case, both the first seal member 6 and the second seal member will be removed from the first opening 22 and the proximal opening 23, respectively, upon removal of the protective shield 8.

In the embodiment as described above, the protective shield 8 was in the form of a sheet. The protective shield 8 may also comprise a rigid plastic casing. The material used for the protective shield 8 is not limited, and when the protective shield 8 comprises a sheet, the protective shield 8 may be produced from a material the same as the first seal member 6 or the second seal member, and when the protective shield 8 comprises a hard plastic case, it may comprise a material the same as the first housing 2 or the second housing 3.

The present invention provides a body fluid-monitoring system comprising a main body of the body fluid-monitoring system and the assembly as describe above. In this body fluid-monitoring system, the main body includes a lancing means for advancing and retracting the lancet, a means for measuring the target component in the body fluid, and a means for detachably holding the assembled housings of the assembly. The assembly is held in the main body by the holder means,

and the connector of the lancet is fitted into a recess formed in the distal end of the lancing means.

Next, the operation of the assembly 1 is described by referring to FIG. 6 and FIGS. 21 to 23.

5 In the case wherein the assembly 1 is sealed in the protective shield 8, when the protective shield 8 is removed from the assembly 1, the first seal member 6 (and the second seal member, if present) will be removed simultaneously with the protective shield 8. Next, the assembly 1 is mounted to
10 the distal end of the body fluid-monitoring system 9. The connector 42 of the lancet 4 then fits into the recess 92 formed in the distal end of the lancing means 91, and a spring 94 connected to the lancing means 91 is thereby compressed. It should be noted that a member such as an O
15 ring 95 is preferably provided at the distal end of the body fluid-monitoring system 9 to enable reliable and gas-tight fixture of the assembly 1 to the distal end of the body fluid-monitoring system 9. The system is now ready for use in the measurement.

20 In the measurement, the body fluid-monitoring system 9 is pressed against the skin with the distal opening 5 of the assembly 1 positioned at the lancing site (see FIG. 21). Compression of the spring 94 is then released by a button 96 to urge the lancing means 91 toward its distal end. The
25 lancing means 91 then pushes the lancet 4, and the puncture needle 41 is thereby pressed into the skin (see FIG. 22). After the puncture, the needle 41 is pulled back into the assembly to be accommodated therein by the recovery of the spring 94 to its original length or by means of a different
30 spring (not shown). The body fluid-monitoring system 9 at this point is shown in FIG. 6.

The body fluid-monitoring system 9 may also have a suction means. The suction means is not limited to any particular type as long as it is capable of reducing the pressure in the interior of the main body housing upon pressing of the opening 5 against the lancing site. Typical suction mechanisms are electric and manual pumps.

When the body fluid (blood) appears from the lanced site after the lancing, the body fluid is introduced from the body fluid guide 34 into the flow path 33, and to the test strip 32 (see FIG. 23). The body fluid that has reached the test strip 32 reacts with the reagents immobilized therein to undergo the color reaction. The color developed at the test strip 32 is measured for the absorption (or emission) by the optical elements (light emitting device 93a or light receiving device 93b) in the body fluid-measuring means 93 for calculation of the level of the target component. After completing the series of operation, the assembly 1 is detached from the distal end of the body fluid-monitoring system 9. The lancet 4 accommodated in the assembly 1 will be simultaneously removed from the system 9.

It should be noted that the body fluid-measuring means 93 of the body fluid-monitoring system 9 is not limited to the optical means as mentioned above, and the assembly 1 should be provided with the body fluid detection means 32 of the type corresponding to the type of the body fluid-measuring means 93. In other words, the body fluid detection means 32 is not limited to the test strip. A typical combination of the body fluid detection means 32 and the body fluid-measuring means 93 is an electrode and a processor for converting the measured current data into the blood glucose value.

In the assembly of the present invention as described above, the second housing may be the one wherein an opening is defined in its body portion; a sleeve is provided in its interior to fittingly receive at least a part of the sleeve of the first housing; and the detection area of the body
5 detection means is arranged on the exterior surface of the sleeve of the second housing. When such structure is adopted, the space required for the body fluid detection means will be reduced, and the size of the assembly can be minimized.

10 Next, the second embodiment of the present invention having a second housing of such structure is described by referring to FIGS. 7 to 12.

FIG. 7 is a cross sectional view of an assembly 101 according to the second embodiment of the present invention.

15 The assembly 101 comprises a first housing 102 and a second housing 103. As shown in the cross sectional view of FIG. 8, the first housing 102 has a sleeve 121 wherein a lancet 104 is movably accommodated. The sleeve 121 has a first opening 122 at its distal end and a proximal opening
20 123 at its proximal end.

As shown in the front view of FIG. 9 and the top view of FIG. 10, the second housing 103 has a second opening 131, and a detection means (a test strip) 132 is provided in the second housing 102.

25 The first housing 102 and the second housing 103 are fixedly secured to each other to constitute the assembly 101 such that the first opening 122 and the second opening 131 surrounding the first opening 122 together form the distal opening 105. The first housing 102 is fixedly secured to the
30 second housing 103 by firmly fitting the first housing 102 in the second housing 103. The contact surfaces of the first housing 102 and the second housing 103 may be adhered or

fused with each other, and alternatively, an engagement means may be provided on both of the first housing 102 and the second housing 103 for engagement therebetween by fitting. Such structure enables the user to mount the first housing
5 102 and the second housing 103 at once as an assembly 101 and eliminates the user from the need of separately mounting the first housing 102 and the second housing 103 to the body fluid-monitoring system. (The body fluid-monitoring system is not shown. An equivalent body fluid-monitoring system,
10 however, is shown in FIG. 6 as the body fluid-monitoring system 9. In the following description, FIG. 6 may be referred for the explanation of the body fluid-monitoring system.) This in turn means that the user can also remove the first housing 102 and the second housing 103 at once as
15 an assembly 101.

As described above, the first housing 102 has the sleeve 121 in its interior, and the lancet 104 is movably accommodated in the sleeve 121. The sleeve 121 is not limited for its shape, and it may be either a cylinder or a
20 rectangular tube. For structural easiness of production, the sleeve 121 is preferably a cylinder.

The lancet 104 has a puncture needle 141 at the distal end, and a connector 142 at the proximal end for connection with the lancing means (not shown but equivalent to the
25 lancing means 91 of the first embodiment) in the body fluid-monitoring system. The shape of the connector 142 is not limited to the convex type as shown in the drawings, and the connector 142 of any shape may be employed as long as it corresponds to the shape of the lancing means. In addition,
30 the connector 142 may not necessary extend beyond the proximal opening 123.

The lancet 104 is secured at a position near the proximal end of the sleeve 121, namely, at a position such that the puncture needle 141 does not extend beyond the first opening 122. The lancet 104 is secured to the sleeve 121 at a firmness such that the puncture needle 141 does not extend beyond the first opening 122 before the use, such that that the operation of connecting the connector 142 with the lancing means can be accomplished, and such that the connector 142 is released from the secured position when the lancet 104 is urged by the pushing force of the lancing means upon its use. The means for securing the lancet 104 is not limited, and the lancet 104 may be secured by providing an engagement means on the interior surface of the sleeve 121 and/or on the exterior surface of the lancet 104; by utilizing the friction between the interior surface of the sleeve 121 and the exterior surface of the lancet 104; or by weakly bonding the contact surfaces with an adhesive or by fusion.

When the proximal opening 123 is not sealed with the second seal member as will be described layer, the lancet 104 before its use is secured at a position near the proximal opening 123 such that the proximal opening 123 is sealed by the lancet 104. Such sealing of the proximal opening 123 may be accomplished by the same method as described for the securing of the lancet 104, and in a typical embodiment, the lancet 104 is fitted into the space defined by a ridge 125 extending in circumferential direction on the interior surface of the sleeve 121 as shown in FIG. 7. Alternatively, the interior of the sleeve 121 may be narrowed near its proximal end and the lancet 104 may be fitted into the narrow proximal end of the sleeve 121, or the lancet 104 may be fitted into the space between protrusions provided in some

part of the interior surface of the sleeve 121 to facilitate gas-tight contact between the interior surface of the sleeve 121 near its proximal end and the exterior surface of the lancet 104 near its proximal end.

5 When the assembly 101 is detached from the body fluid-monitoring system, the lancet 104 which is connected to the lancing means of the body fluid-monitoring system through the connector 142 will be pulled back toward the proximal end of the first housing 102. When the lancet 104 is fittingly
10 secured in the securing/sealing means as described above such as the ridge 125 extending in circumferential direction, the connector 142 becomes detached from the lancing means, and the assembly 101 can be finally detached from the body fluid-monitoring system. In the course of the detachment, the
15 puncture needle 141 becomes firmly secured in the sleeve 121, and the puncture needle 141 is reliably prevented from extending beyond the second opening 131. Accidental prickling of the skin by the puncture needle 141 after its use is thereby prevented.

20 Since the lancet 104 must fit in the sleeve 121 near its proximal end to seal the proximal opening 123, the lancet 104 should have a cross section which corresponds to the cross section of the sleeve 121. In principle, the lancet 104 may be formed from the same material as the first housing 102 or
25 the second housing 103 as will be described below, and the material used for the lancet 104 may preferably have some flexibility.

 The interior of the first housing 102 is maintained in sterilized condition by sterilizing the sleeve 121 after
30 enclosing the lancet 104 in its interior and sealing the proximal opening 123; or enclosing the sterilized lancet 104 in the interior of the sterilized sleeve 121 and maintaining

the interior of the sleeve 121 in sealed conditions until its use. Of these procedures, sterilization of the sleeve 121 after enclosing the lancet 104 and sealing the proximal opening 123 is advantageous for ease of operation. The sterilization may be conducted by any method, for example, by sterilization with EOG, γ ray, electron beam, or the like. As described above, the first housing 102 is assembled with the second housing 103 to produce the assembly 101 after ensuring that the sterility of the interior of the sleeve 121 will be maintained until its use.

Exemplary materials used for the first housing 102 include ABS, polyethylene, polypropylene, polystyrene, polyvinyl chloride, polyvinylidene chloride resin, polyphenylene oxide, thermoplastic polyurethane, polymethylene methacrylate, polyoxyethylene, fluororesin, polycarbonate, polyamide, acetal resin, acryl resin, polyethylene phthalate and other thermoplastic resins used in the injection molding; and phenol resin, epoxy resin, silicone resin, unsaturated polyester resin and other thermosetting resins.

The interior of the sleeve 121 is kept in gas-tightly sealed conditions by sealing the first opening 122 and the proximal opening 123. The first opening 122 is sealed by the first seal member 106. As shown in the drawings, the first seal member 106 is in the form of a plug fitted and secured in the first opening 122 to gas-tightly seal the interior of the sleeve 121. It should be noted that the first seal member 106 may also be in the form of a lid or a plug for ease of bonding by adhesion or fusion as well as peeling. Although it is preferable that the proximal opening 123 is gas-tightly sealed by fittingly securing the lancet 104 as described above, the proximal opening 123 may also be sealed

with a second seal member (not shown) similar to the first seal member 106.

The second housing 103 has the second opening 131, and a detection means (a test strip) 132 is provided in the second housing 102. In the second embodiment, the test strip 132 is provided such that the plane of the test strip 132 is substantially parallel to the axial direction of the sleeve 121 when the first housing 102 and the second housing 103 are assembled into the assembly 101. In such structure, the test strip 132 is secured to the exterior surface of the sleeve 121. In the present embodiment, the test strip 132 placed in a test strip housing 132a is secured to the second housing 103. It should be noted that the body fluid detection means is not limited to the test strip, and any medium suitable as a body fluid detection means of the body fluid monitoring system may be used.

The material used for the second housing 103 may be the same as those described for the first housing 102. When the body fluid-measuring means in the body fluid monitoring system is an optical means which conducts the measurement by detecting the color reaction on the test strip, the housing 103 may preferably comprise a non-transparent material to thereby shut out the influence of exterior light and increase the measurement accuracy. For ease of confirming the movement of the body fluid in the flow path 133, the second housing 103 may comprise a colored, translucent resin.

In this embodiment, a body fluid inlet 133a and a flow path 133 for introducing the body fluid from the body fluid inlet 133a to the test strip 132 by capillary action are formed in the periphery of the second opening 131. FIG. 12 is an enlarged cross sectional view of the second housing 103 of the second embodiment taken along lines Y-Y of FIG. 10.

As shown in FIG. 12, the flow path 133 is formed from flow path sections 133c, 133d, and 133e intersecting with each other at an angle. More specifically, the flow path section 133c extends from the body fluid inlet 133a, and the flow path section 133d rises upward from the flow path section 133c along the axis of the second housing 103, and the flow path section 133e extends from the flow path section 133d toward the test strip 132. In this embodiment, the flow path 133 is formed as a gap when the test strip housing 132a is assembled to the second housing 103.

The cross section and the length of the flow path 133 may vary in accordance with the amount of the body fluid required for the measurement. The flow path 133, however, is preferably designed such that the volume of the body fluid remaining in the flow path 133 is minimized. The flow path 133 may typically comprise a groove having a semi-circular, V-shaped, or rectangular cross section, and for reducing the amount of the body fluid remaining in the flow path 133, the flow path 133 may preferably comprise a shallow groove having a rectangular cross section. The depth is preferably in the range of about 0.05 to about 0.5 mm, and the width is preferably in the range of from about 0.5 to about 3 mm. The flow path 133 may preferably have a short length although the length may depend on the position of the body fluid-measuring means of the body fluid monitoring system. The suitable length, however, is in the range of from about 5 mm to about 15 mm.

When the body fluid is introduced along the flow path 133 from the body fluid inlet 133a to the test strip 132 in a closed system, the capillary action may stop before the reaching of the body fluid to the test strip 132. In view of such situation, provision of an air vent is necessary, and to

be more specific, the test strip holder 136 provided on the exterior surface of the housing 103 as a recess is formed to a structure as shown in FIG. 11 in its plan view. In this structure, the test strip supports 138 and the air vent 137 at the end 133b of the flow path 133 on the side of the test strip 132 are formed so that the test strip 132 can be secured as shown in FIG. 12 wherein a gap 139a is defined between the periphery of the test strip 132 and the periphery of the test strip holder 136, and a gap 139b is defined between the lower surface of the test strip 132 and the test strip holder 36. The test strip 132 is supported between the test strip supports 138 and the end 133b of the flow path 133.

As shown in FIG. 12, in the case of the flow path 133 in the second embodiment of the present invention, the flow path section 133c extending from the body fluid inlet 133a intersects at an angle with the flow path section 133d extending along the axis of the second housing 103, and the flow path section 133d intersects at an angle with the flow path section 133e extending toward the test strip 132. When the fluid of high viscosity as in the case of the body fluid flows along the flow path of such configuration, meniscus is likely to be formed at the front end of the liquid flow due to the surface tension. In view of such situation, in the flow path 133 of this embodiment, a projection extending into the flow path 133 is preferably formed at each corner of the flow path 133 so that the fluid forming the meniscus may contact the projection as the fluid advances through the flow path. To be more specific, a projection 135a extending into the flow path section 133c is formed at the corner defined between the flow path sections 133c and 133d, and a projection 135b extending into the flow path section 133b is formed in the test strip 132. The projections 135a and 135b

will release the surface tension responsible for the meniscus formation.

It should be noted that meniscus is a phenomenon that occurs in a tube and that becomes evident when the advance of the liquid through the tube is terminated by the action of surface tension, and a concave or convex surface is formed on the liquid surface. When the tube is wetted by the liquid, the meniscus formed is a concave meniscus and the liquid surface will be lifted along the tube interior surface. Meniscus formation is most likely to occur at or near the corner of a capillary.

The flow path 133 may be formed from the same material as the second housing 103. The flow path 133, however, is preferably formed from a material having a high hydrophilicity such as acryl resin. When the material is not sufficiently hydrophilic, the surface of the flow path 133 may be treated to impart the surface with the hydrophilicity to improve the sucking of the body fluid into the flow path 133. Typical such treatments include physical activations such as ozone treatment, plasma treatment, glow discharge, corona discharge, UV irradiation; coating of a surfactant, water soluble silicone, hydroxypropyl cellulose, polyethylene glycol, polypropylene glycol, or the like.

The body fluid inlet 133a is preferably formed with a body fluid guide 134 on its periphery. The body fluid guide 134 has the function of guiding the body fluid which becomes in contact with the guide 134 to the body fluid inlet 133a. The body fluid guide 134 may be formed from the same material as the second housing 103 or the flow path 133, and the body fluid guide 134 is preferably imparted with hydrophilicity as in the case of the flow path 133. The body fluid guide 134 should have a structure which is capable of rapidly guiding

the body fluid to the body fluid inlet 133a, and which is capable of retaining a large amount of the body fluid to prevent the spreading or flowing out of the body fluid to surrounding areas. When the body fluid guide 134 has an
5 inappropriate shape, the excess body fluid that was not sucked from the body fluid inlet 133a will spread around the second opening 131 to induce sanitary problem. The body fluid guide 134 of an inappropriate shape will also result in an insufficient sucking of the body fluid into the flow path
10 133, and the amount of body fluid required for the measurement will be increased to result in the increased burden of the patient. A typical body fluid guide 134 comprises guide members 134a and 134b in the form of rails provided on the periphery and on opposite sides (on the right
15 and left) of the body fluid inlet 133a. It should be noted that the opposed interior surfaces of guide members 134a and 134b may be either parallel to each other or unparallel such that the space defined between the opposed interior surfaces widen toward the center of the body fluid droplet. The
20 latter structure is more preferable since the suction of the body fluid is more reliably and more rapidly conducted. The body fluid guides 134 may be the one further comprising a guide member covering the lower direction of the body fluid inlet 133a. The body fluid guides 134 of other embodiments
25 are also acceptable, and the body fluid guide 134 may be the one wherein the body fluid inlet 133a is covered in all four directions (right, left, upward and downward directions).

The body fluid guide 134 may preferably define an interior space with a width of about 1 mm to about 3 mm, a
30 height of about 0.5 mm to about 3 mm, and a length of about 1 mm to about 3 mm since the body fluid in an amount of about 4 μ l forms a droplet having a diameter of about 3 mm and the

guide 134 may preferably define a space equivalent to the maximum required volume of the body fluid. The height of the guide 134a and 134b is preferably equivalent to the maximum diameter of the body fluid inlet 133a.

5 In the lancing, the puncture needle 141 passes near the tip of the body fluid guide 134 or between said body fluid guide members before puncturing the skin. When the skin is punctured with the puncture needle 141 and the body fluid droplet of required volume is formed, the droplet contacts
10 the body fluid guide 134. The body fluid is then guided into the flow path 133, and to the test strip 132. Preferably, the distance between the course of the puncture needle 141 and the tip of the body fluid guide 134 is about 3 mm at most, and more preferably, up to about 1 mm in view of the volume
15 of the body fluid required for the measurement.

The surface of the second housing 103 near the second opening 131 may be formed as a curved surface 105a with a curve corresponding to the lancing site. The curved surface 105a will then play the role of guiding the distal opening
20 105 to the lancing site (for example, on the finger tip or belly). In the embodiment shown in FIG. 9, the second housing 103 is formed with the curved surface 105a having a curve corresponding to the finger, and the recessed area of the curved surface 105a facilitates positioning of the distal
25 opening 105 to the lancing site on the finger.

The body fluid detecting means or the test strip 132 is not limited to any particular type, and any material matching with the body fluid-measuring means of the body fluid monitoring system may be used. For example, when the body
30 fluid-measuring means is an optical measurement means which detects color reaction in the test strip as in the case of the measurement of glucose in blood, the test strip 132 may

be impregnated with glucose oxidase, peroxidase, and a chromogenic agent followed by drying. The test strip 132 is preferably a porous membrane in the form of a nonwoven fabric, a woven fabric, a stretched sheet, or the like prepared from a material such as a polyester, a polyamide, a polyolefin, a polysulfone, a cellulose, or the like. Since the test strip 132 is impregnated with various reagents as well as the body fluid, the test strip 132 is preferably the one formed from a hydrophilic material or the one which has been treated to impart hydrophilicity. The test strip 132 may be either a mono-layer sheet or a multi-layer sheet. When the test sheet 132 comprises a multi-layer sheet, the layers should be densely stacked on one another as shown in the drawings.

When the first housing 102 wherein at least the puncture needle 141 is enclosed in sterilized state by maintaining the seal of the sleeve 121 as described above and the second housing 103 having the body fluid detection means are fixedly secured to each other to form the assembly 101 having the distal opening 105, the whole assembly 101 is preferably sealed in a protective shield 108. The structure of the protective shield 108 is not limited as long as components of the assembly 101 can be sealed in its interior. The embodiment of the protective shield 108 shown in the drawings is the one in the form of a sheet, and the protective shield 108 of this embodiment can be removed immediately before the use by tearing the sheet from the notch 181. If the first seal member 106 is provided with a connector 161, and the connector 161 is connected to a part of the interior of the protective shield 108, the first seal member 106 may be simultaneously removed from the first opening 122 upon removal of the protective shield 108. Similarly, when the

second seal member is present, the second seal member may also be connected to the protective shield 108 in its interior, and in such case, both the first seal member 106 and the second seal member will be removed from the first opening 122 and the proximal opening 123, respectively, upon
5 removal of the protective shield 108.

The protective shield 108 is not limited to the one in the form of a sheet, and may comprise a rigid plastic casing. The material used for the protective shield 108 is not
10 limited to any particular type, and when the protective shield 108 is in the form of a sheet, the material used may be those used for the first seal member 106 or the second seal member such as a film coated with aluminum, and when the protective shield 108 comprises a rigid plastic casing, the
15 material used may be those used for the first housing 102 or the second housing 103.

The assembly 101 according to the second embodiment can be used substantially as in the case of the assembly 101 according to the first embodiment of the present invention.

20

Industrial Applicability

The present invention provides an assembly for use with a body fluid-monitoring system wherein the lancet (the puncture needle) has been sterilized and the sterilized
25 condition is maintained until its use while adverse effects caused by the sterilization of the lancet such as the adverse effects which might be induced in the reagents impregnated in the test strip are avoided. Use of the assembly according to the present invention ensures safe measurement due to the
30 sterilized conditions maintained until the use of the lancet and simple and reliable attachment and detachment of the

lancet and test paper units since both units can be simultaneously handled.

The body fluid-collecting and detecting unit of the present invention has a body fluid guide which enables
5 efficient introduction of the body fluid into its interior, and the measurement can be accomplished by lancing and collecting minimum amount of the body fluid. Therefore, milking and massaging of the lanced site is no longer necessary.

CLAIMS

1. An assembly having a lancet and a means for collecting and detecting a body fluid wherein said assembly is to be detachably mounted on a body fluid-monitoring system having a lancing means and said assembly comprises:

a lancet section comprising

a lancet having a puncture needle on its distal end and a connector on its proximal end for connection to said lancing means of the body fluid-monitoring system, and

a first housing having a sleeve which movably accommodates said lancet in its interior, and which has a first opening on its distal end to enable projection of the needle into its exterior and a proximal opening to enable connection of said connector with said lancing means of the body fluid-monitoring system, and

wherein said lancet before the lancing is secured in said sleeve at a position near its proximal opening capable to gas-tightly seal said sleeve;

a body fluid-collecting and detecting section comprising a body fluid detection means and a second housing having a second opening for introducing the body fluid into said detection means;

a first seal member for sealing said first opening and optionally a second seal member for sealing said proximal opening;

and

wherein said first housing is gas-tightly sealed with both said first seal member for sealing said first opening and said lancet or said optional second seal member for sealing said proximal opening; and

said first housing and said second housing are fixedly integrated each other such that said first opening of said first housing and said second opening of said second housing together define a distal opening to enable the projection of said puncture needle to the exterior of said assembly, and the one-piece assembly having the lancet section and the body fluid-collecting and detecting section is thereby constituted.

2. An assembly according to claim 1 produced by sterilizing said lancet section having said puncture needle accommodated in said first housing with said first opening and said proximal opening sealed; and assembling the sterilized lancet section with said body fluid-collecting and detecting section to constitute a one-piece assembly.

15

3. An assembly according to claim 1 wherein the entire assembly after assembling is covered with a protective shield.

4. An assembly according to claim 2 wherein the entire assembly after assembling is covered with a protective shield.

20

5. An assembly according to claim 3 or 4 wherein said first seal member is connected to said protective shield and said first seal member is removed from said first opening simultaneously with the removal of said protective shield.

25

6. An assembly according to any one of claims 2 to 5 wherein said puncture needle remains sterilized until said first seal member is removed from said first opening.

30

7. An assembly according to any one of claims 1 to 6 wherein said first housing has a means for preventing detachment of said lancet after its use.

5 8. An assembly according to claim 7 wherein said detachment-preventing means also serves the function of sealing said proximal opening of said sleeve.

9. An assembly according to any one of claims 1 to 8
10 wherein said second housing is defined with a flow path for guiding the body fluid from said distal opening to said body fluid detection means by capillary action, and an inlet port for guiding said body fluid into said flow path.

15 10. An assembly according to claim 9 wherein said flow path in the second housing comprises a plurality of flow path sections between which corners are defined at an angle, and a projection protruding into the flow path is provided on each corner so that the tip of the projection contacts with
20 meniscus of the body fluid formed at the corner.

11. An assembly according to claim 9 or 10 wherein said inlet port has a body fluid guide formed along its periphery.

25 12. An assembly according to claim 11 wherein said body fluid guide comprises two or more guide members and said guide members are projections formed on the periphery of said inlet port.

30 13. An assembly according to claim 11 or 12 wherein said body fluid guide is located inside of said second opening.

14. An assembly according to any one of claims 11 to 13 wherein said body fluid guide has a constitution comprising two side members and a lower plate member.

5 15. An assembly according to claim 14 wherein said lower plate member has a downwardly extending projection on a distal section thereof.

10 16. An assembly according to claim 14 or 15 wherein said body fluid guide members are designed such that the width between said side members increases from the side of said inlet to the side of distal end, and surface tension of said body fluid is lower in the interior space enclosed with said fluid guide members than in the interior of said flow path,
15 and the distal ends of said side members are mounted at an angle less than 90° to the bottom face of said second opening.

17. An assembly according to any one of claims 1 to 16 wherein said second housing has a sleeve in its interior to
20 fittingly receive at least a part of the sleeve of the first housing, and said sleeve of the second housing has an opening in its body; and

detection area of the body fluid detection means is
secured to the exterior surface of said sleeve of the second
25 housing.

18. An assembly according to any one of claims 11 to 17 wherein said puncture needle passes near the tip of said body
fluid guide or between side members of said body fluid guide
30 during the puncture.

19. An assembly having a lancet assembled with a body fluid-collecting and detecting section, wherein said lancet has a puncture needle on its distal end and a connector on its proximal end for connection to the lancing means of the body fluid-monitoring system, and said lancet section has been
5 gas-tightly sealed under sterilized conditions.

20. A body fluid-collecting and detecting unit comprising:
an inlet port for the body fluid;
10 a test strip which enables measurement of the target component in the body fluid;
a flow path for guiding the body fluid from said inlet port to said test strip by capillary action; and
a body fluid guide formed along the periphery of the
15 inlet port.

21. A body fluid-collecting and detecting unit according to claim 20 wherein said body fluid guide comprises two or more guide members and said guide members are projections formed
20 on the periphery of said inlet port.

22. A body fluid-collecting and detecting unit according to claim 20 or 21 wherein said body fluid-collecting and detecting unit is accommodated with a housing having an
25 opening, and said body fluid guide is located inside of said opening.

23. A body fluid-collecting and detecting unit according to any one of claims 20 to 22 wherein said body fluid guide has
30 a constitution comprising two side members and a lower plate member.

24. A body fluid-collecting and detecting unit according to claim 23 wherein said lower plate member has a downwardly extending projection on a distal section thereof.

5 25. A body fluid-collecting and detecting unit according to any one of claims 23 to 24 wherein said body fluid guide members are designed such that the width between said side members increases from the side of said inlet to the side of distal end, and surface tension of said body fluid is lower
10 in the interior space enclosed with said fluid guide members than in the interior of said flow path, and the distal ends of said side members are mounted at an angle less than 90° to the bottom face of said second opening.

15 26. A body fluid-monitoring system comprising a main body of the body fluid-monitoring system and the assembly of any one of claims 1 to 19, wherein said main body includes:

a lancing means having a recess at its distal end,
a means for measuring the target component in the body
20 fluid, and

a holder means for detachably holding the assembled housings of the assembly, and

said assembly is held by said holder means, and the connector of said lancet is fitted into said recess formed in
25 the distal end of said lancing means.

FIG. 1

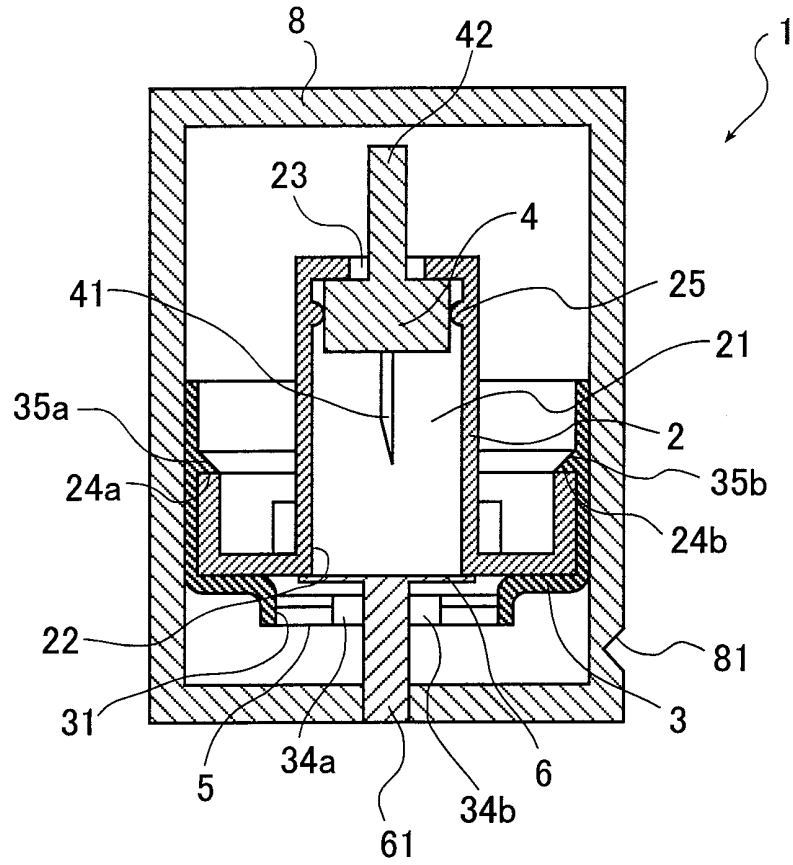

FIG. 2

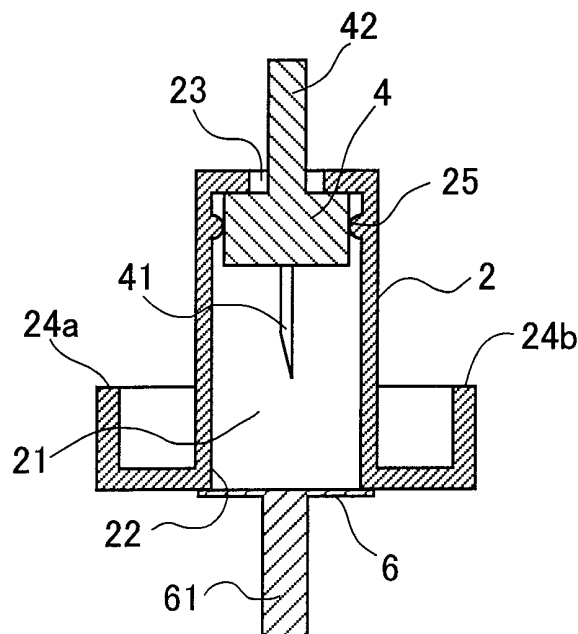

FIG. 3

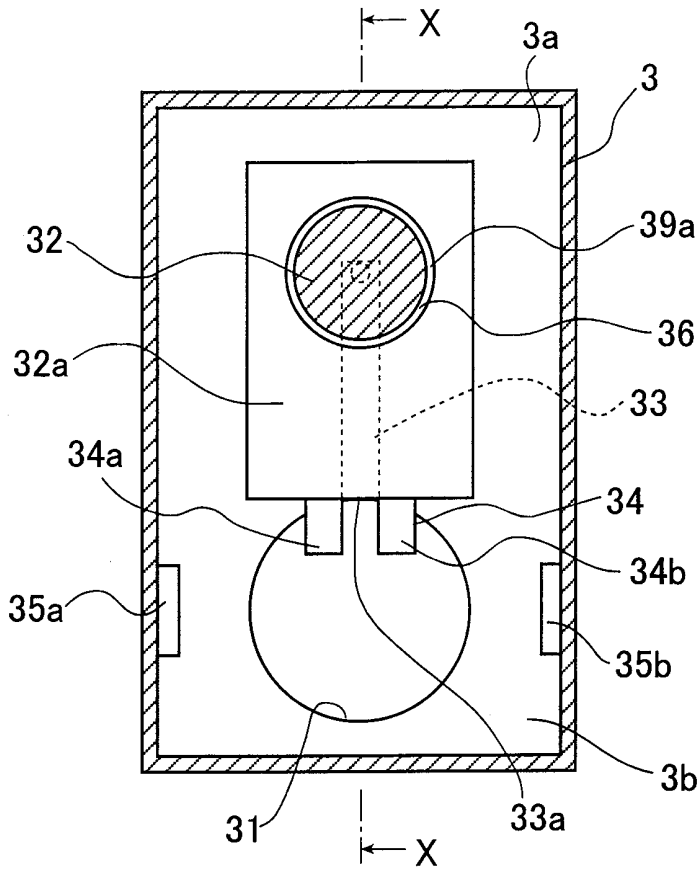

FIG. 5

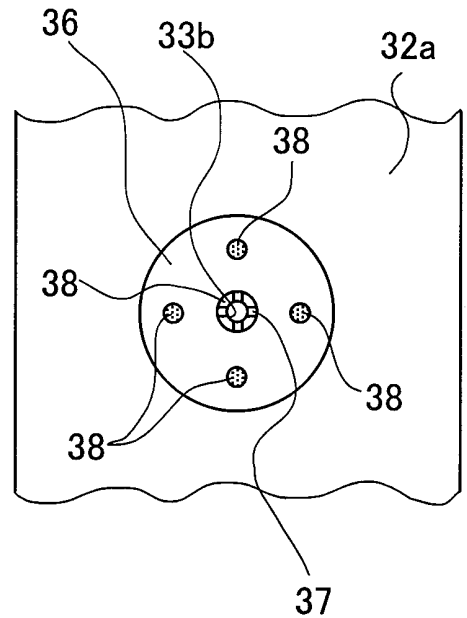

FIG. 4

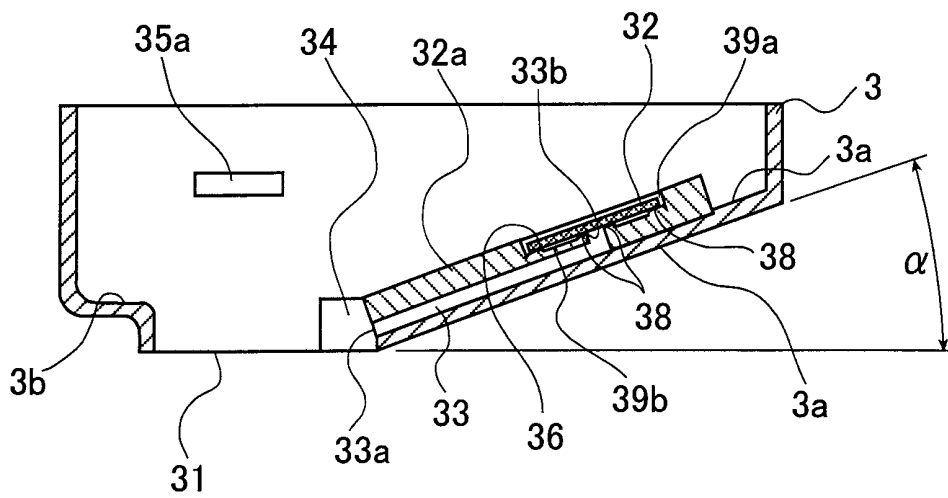

FIG. 6

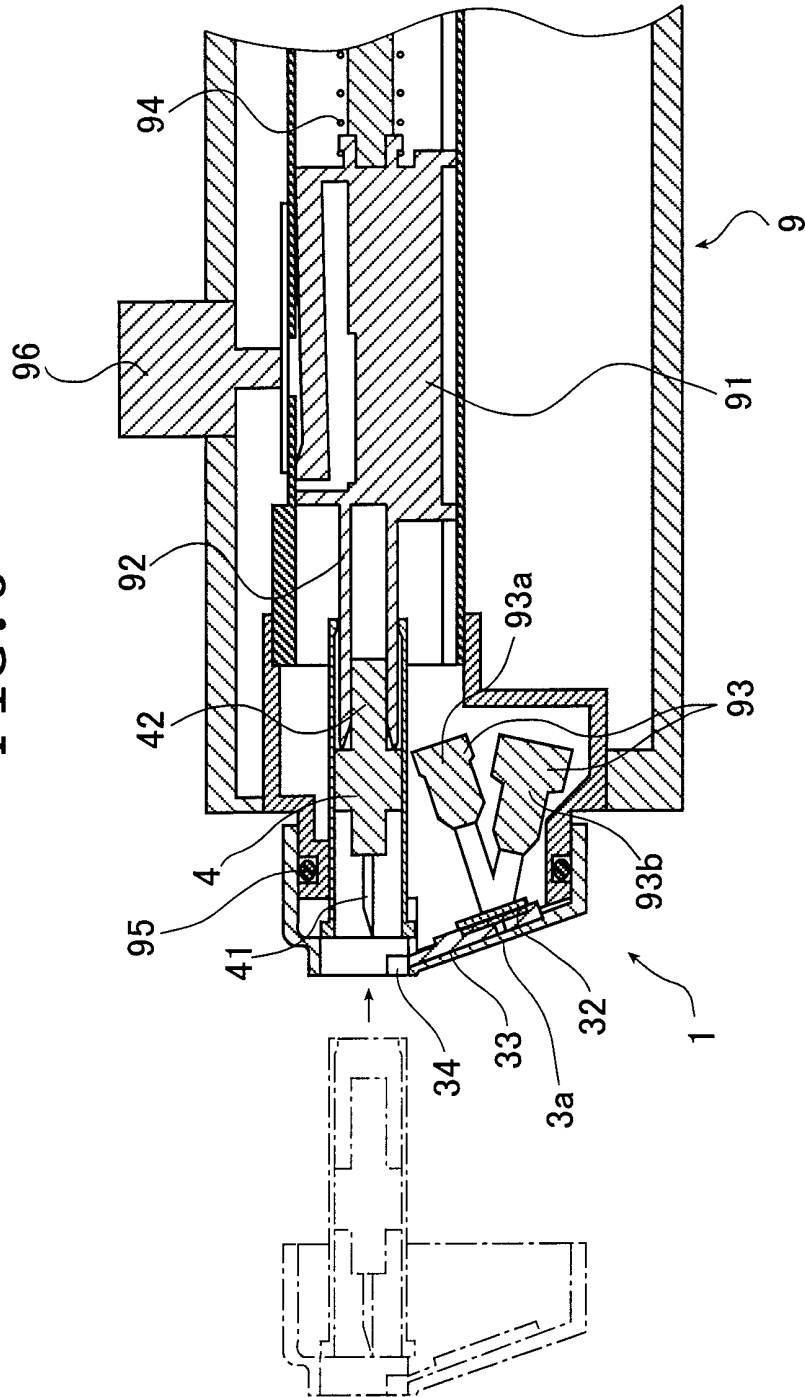

FIG. 7

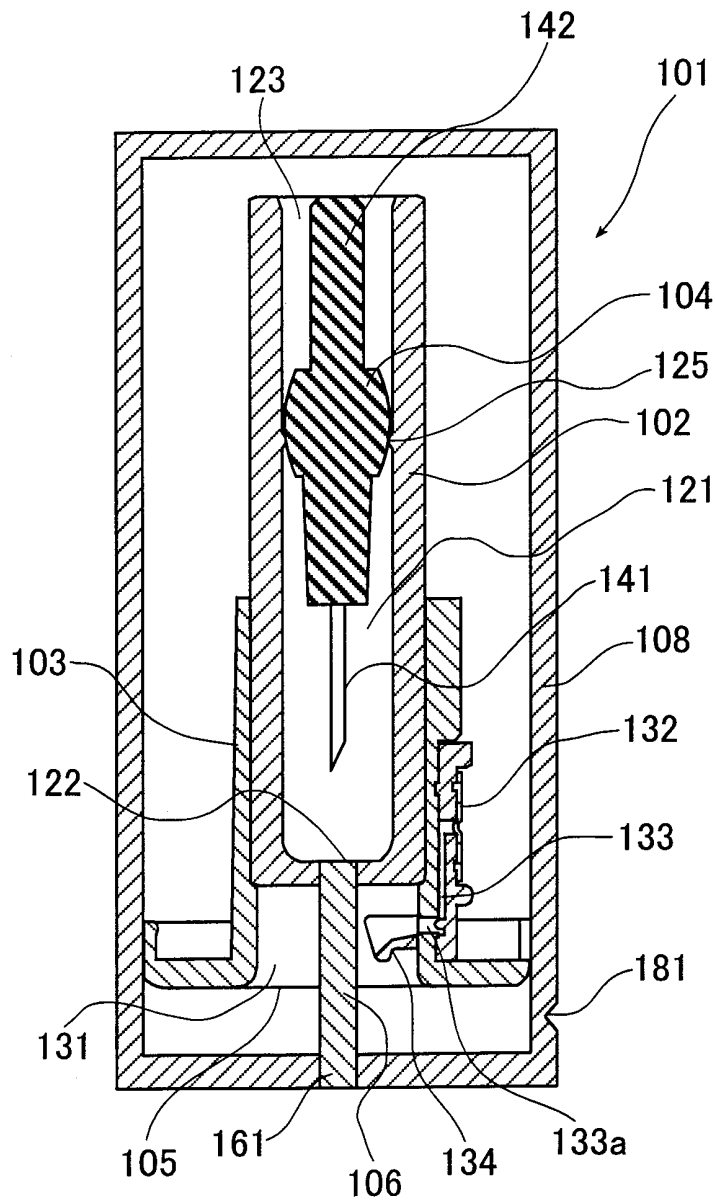
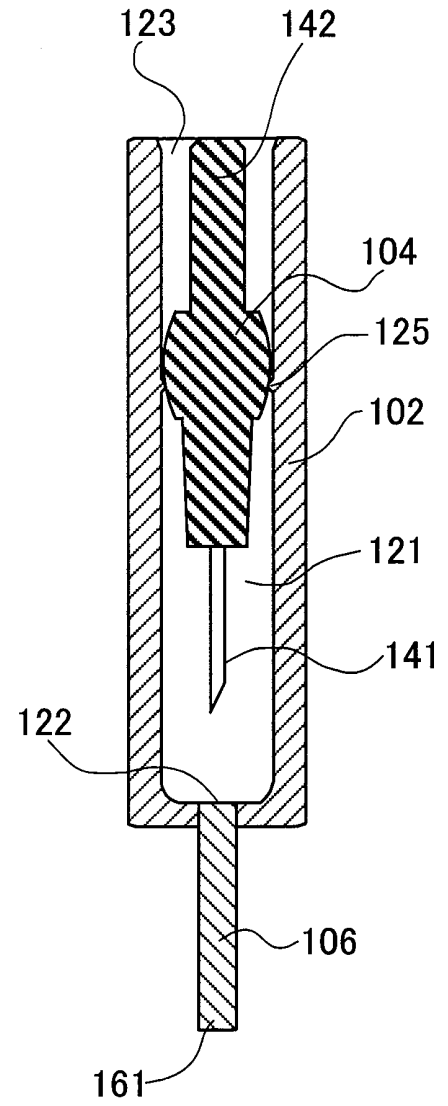

FIG. 8



5/11

FIG. 9

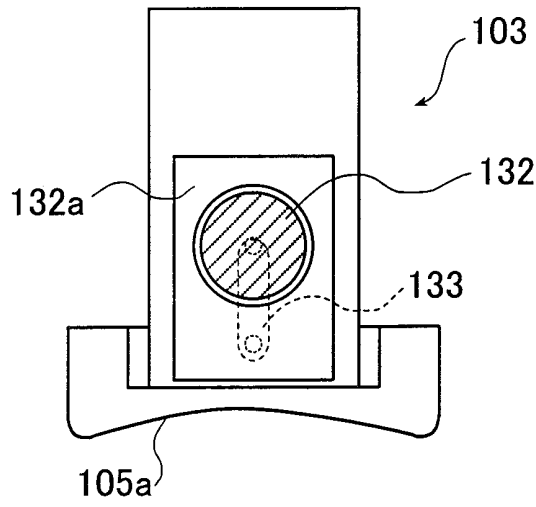

FIG. 10

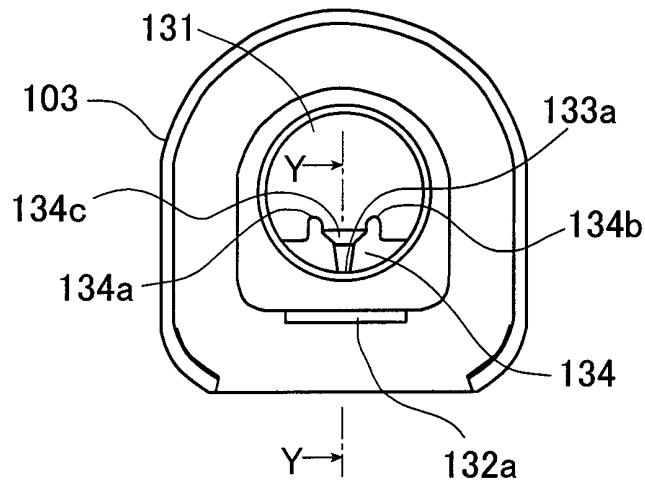

FIG. 11

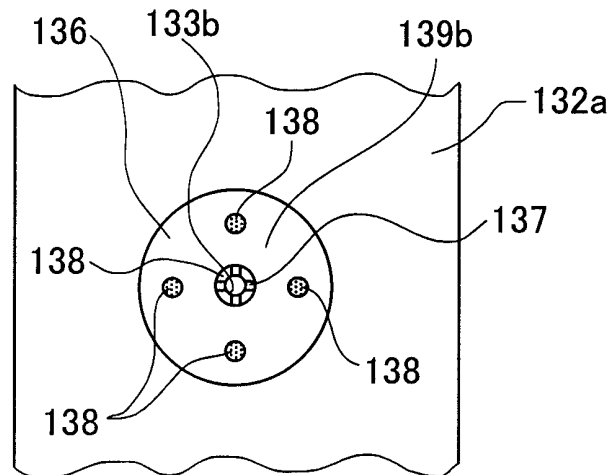
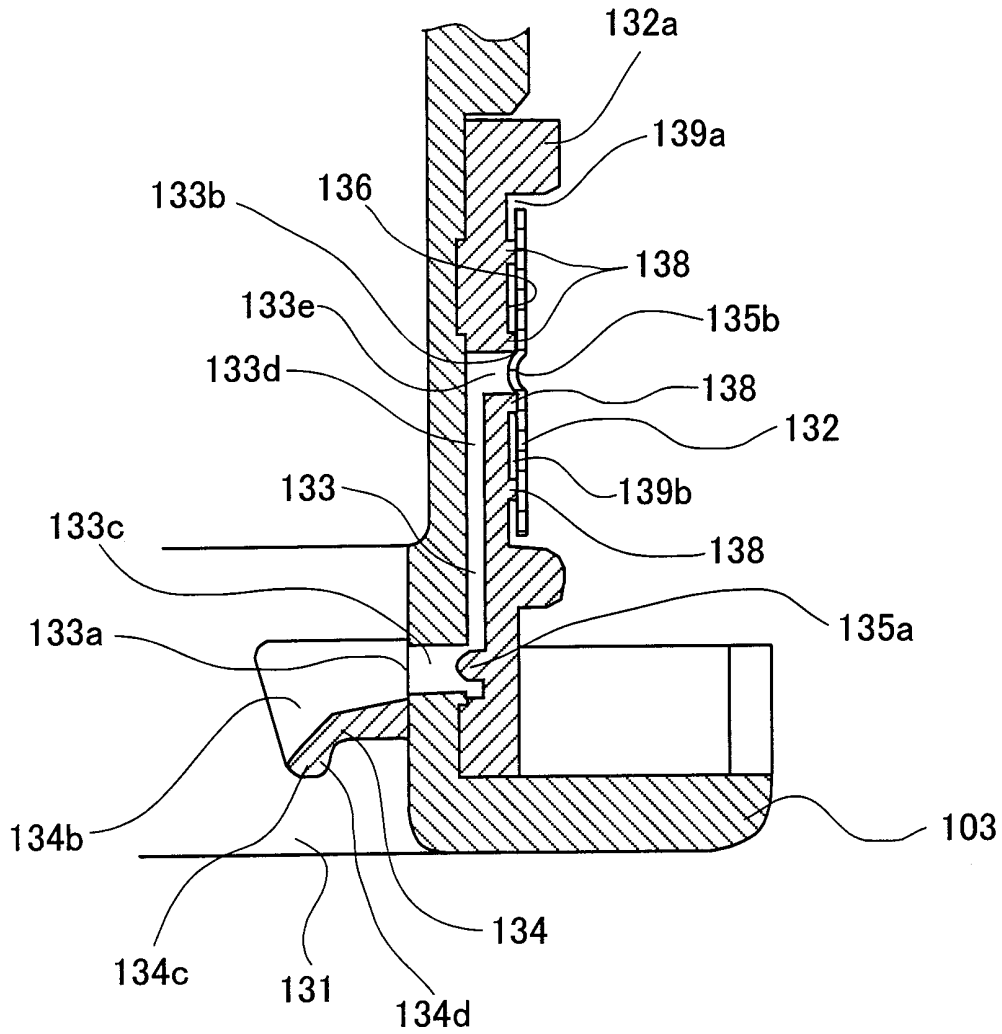

FIG. 12



7/11

FIG. 13

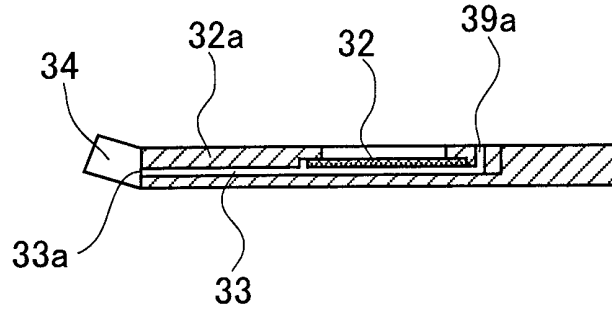

FIG. 14

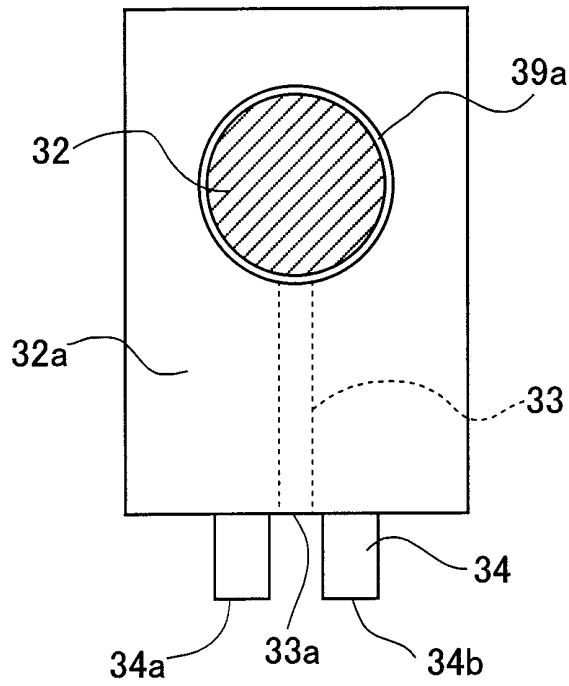

FIG. 15

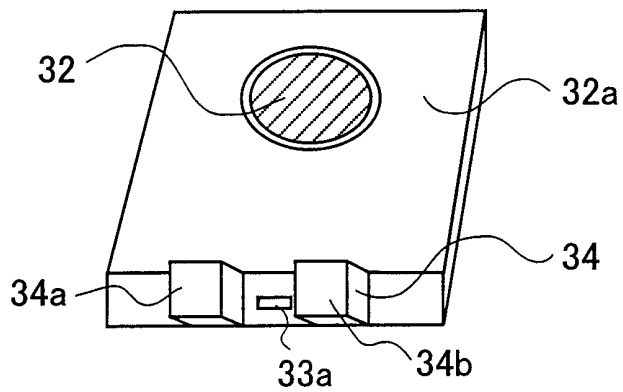

FIG. 16

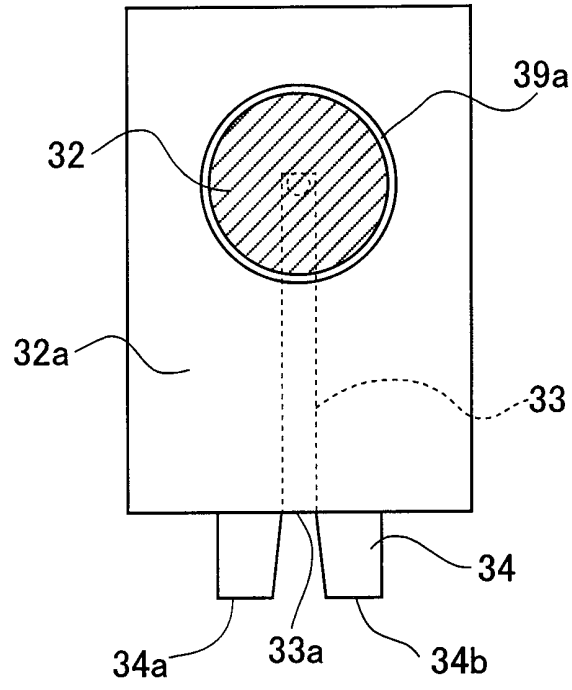

FIG. 17

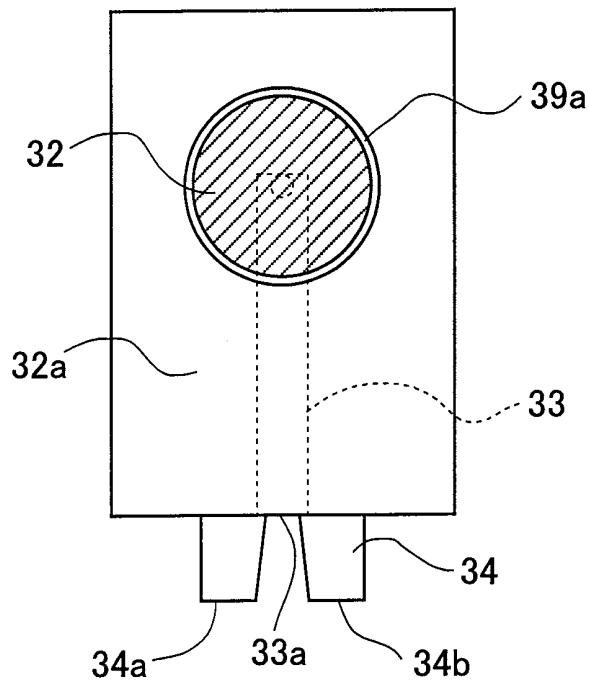

FIG. 20

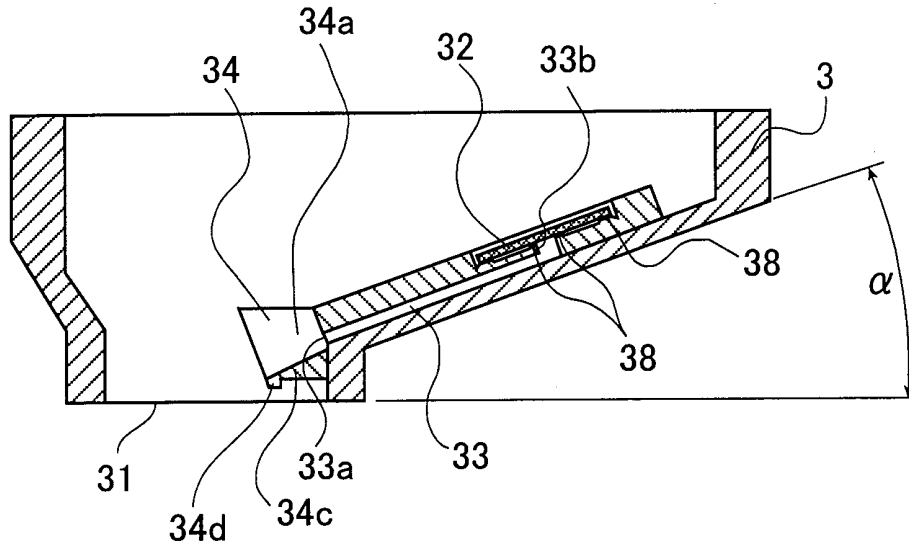

FIG. 21

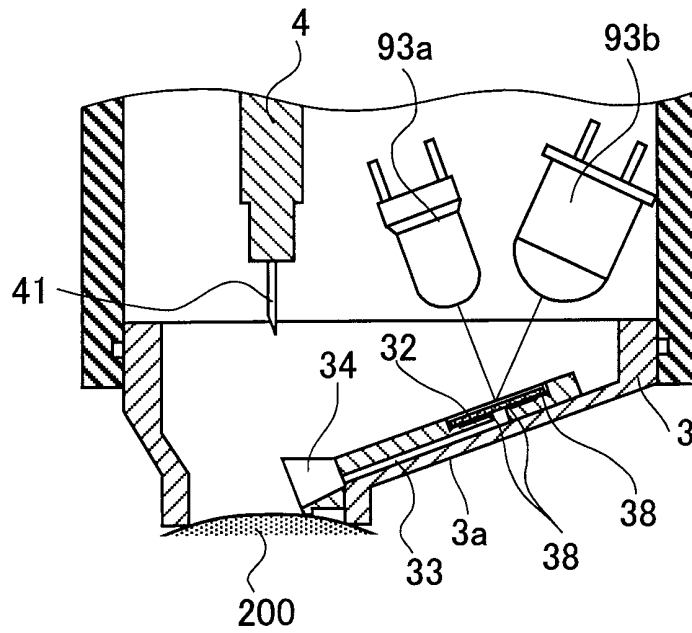

FIG. 22

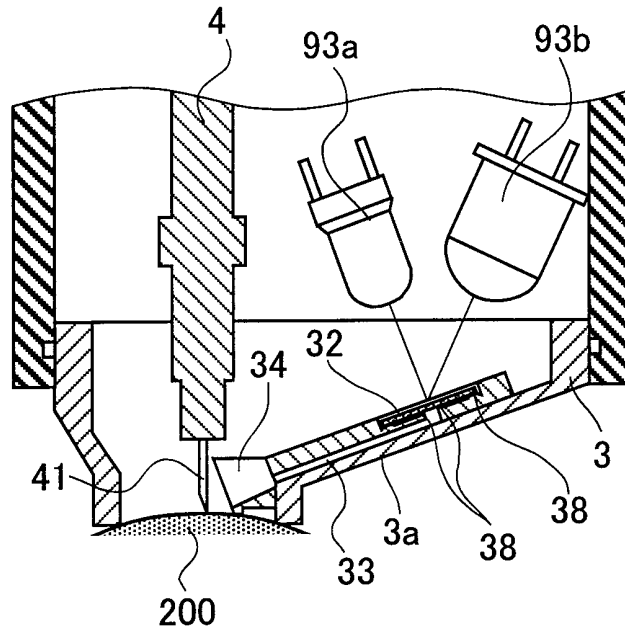
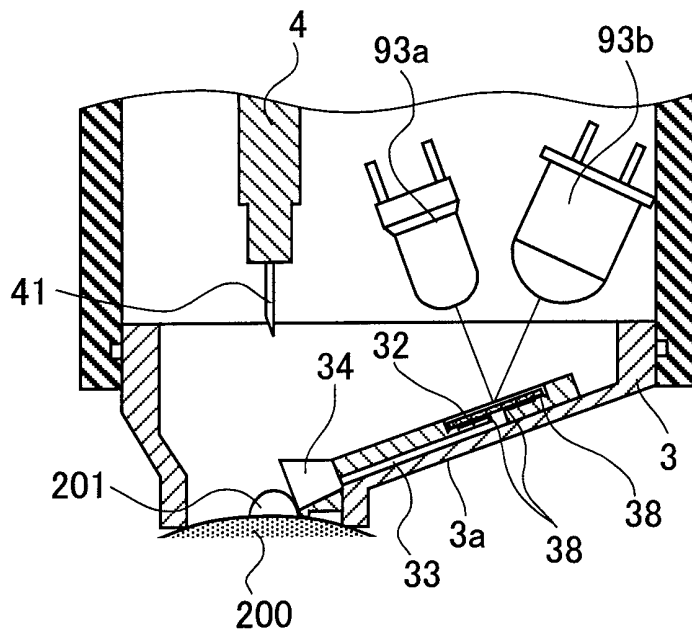

FIG. 23



INTERNATIONAL SEARCH REPORT

International Application No

PCT/JP 99/07325

A. CLASSIFICATION OF SUBJECT MATTER
 IPC 7 A61B5/145

According to International Patent Classification (IPC) or to both national classification and IPC

B. FIELDS SEARCHED

Minimum documentation searched (classification system followed by classification symbols)
 IPC 7 A61B

Documentation searched other than minimum documentation to the extent that such documents are included in the fields searched

Electronic data base consulted during the international search (name of data base and, where practical, search terms used)

C. DOCUMENTS CONSIDERED TO BE RELEVANT

Category °	Citation of document, with indication, where appropriate, of the relevant passages	Relevant to claim No.
Y	EP 0 199 484 A (AUDIO BIONICS INC) 29 October 1986 (1986-10-29)	19,20
A	column 14, line 27 -column 16, line 5 ---	1,22
Y	GB 2 183 159 A (SARSTEDT KUNSTSTOFF) 3 June 1987 (1987-06-03)	20
A	page 3, line 59 - line 121 ---	21,23,25
Y	EP 0 678 278 A (ARTA PLAST AB) 25 October 1995 (1995-10-25)	19
A	column 4, line 50 -column 5, line 6 column 7, line 6 - line 34 ---	1,20
A	EP 0 255 338 A (GLYME VALLEY TECHN LTD) 3 February 1988 (1988-02-03)	1,19,20
	column 8, line 25 -column 10, line 5 --- -/--	

Further documents are listed in the continuation of box C. Patent family members are listed in annex.

° Special categories of cited documents :

"A" document defining the general state of the art which is not considered to be of particular relevance

"E" earlier document but published on or after the international filing date

"L" document which may throw doubts on priority claim(s) or which is cited to establish the publication date of another citation or other special reason (as specified)

"O" document referring to an oral disclosure, use, exhibition or other means

"P" document published prior to the international filing date but later than the priority date claimed

"T" later document published after the international filing date or priority date and not in conflict with the application but cited to understand the principle or theory underlying the invention

"X" document of particular relevance; the claimed invention cannot be considered novel or cannot be considered to involve an inventive step when the document is taken alone

"Y" document of particular relevance; the claimed invention cannot be considered to involve an inventive step when the document is combined with one or more other such documents, such combination being obvious to a person skilled in the art.

"&" document member of the same patent family

Date of the actual completion of the international search	Date of mailing of the international search report
24 March 2000	31/03/2000

Name and mailing address of the ISA European Patent Office, P.B. 5818 Patentlaan 2 NL - 2280 HV Rijswijk Tel. (+31-70) 340-2040, Tx. 31 851 epo nl, Fax: (+31-70) 340-3016	Authorized officer Knüpling, M
--	-----------------------------------

INTERNATIONAL SEARCH REPORT

International Application No
PCT/JP 99/07325

C.(Continuation) DOCUMENTS CONSIDERED TO BE RELEVANT		
Category °	Citation of document, with indication, where appropriate, of the relevant passages	Relevant to claim No.
A	US 5 569 287 A (TEZUKA SHIGERU ET AL) 29 October 1996 (1996-10-29) column 2, line 51 -column 3, line 29 -----	1,19,20

INTERNATIONAL SEARCH REPORT

information on patent family members

International Application No

PCT/JP 99/07325

Patent document cited in search report		Publication date	Patent family member(s)	Publication date
EP 0199484	A	29-10-1986	US 4627445	A 09-12-1986
			US 4637403	A 20-01-1987
			AT 86843	T 15-04-1993
			AU 5699086	A 05-11-1986
			CA 1277896	A 18-12-1990
			DE 3687994	A 22-04-1993
			DK 589486	A 08-12-1986
			WO 8605966	A 23-10-1986
			US 5279294	A 18-01-1987
			US 4787398	A 29-11-1988
			JP 61286738	A 17-12-1986
			GB 2183159	A
FR 2590152	A 22-05-1987			
IT 1198126	B 21-12-1988			
JP 62167534	A 23-07-1987			
US 4805635	A 21-02-1989			
EP 0678278	A	25-10-1995	DE 4212723	C 04-11-1993
			AT 137939	T 15-06-1996
			AU 3695893	A 21-10-1993
			CA 2093580	A, C 17-10-1993
			CN 1078375	A 17-11-1993
			CZ 280755	B 17-04-1996
			DK 565819	T 29-07-1996
			EP 0565819	A 20-10-1993
			ES 2086796	T 01-07-1996
			FI 931681	A 17-10-1993
			GR 3020643	T 31-10-1996
			HU 66986	A 30-01-1995
			JP 2591895	B 19-03-1997
			JP 6022941	A 01-02-1994
			KR 9610978	B 14-08-1996
			NO 930924	A 18-10-1993
			PL 298079	A 15-11-1993
			SK 32093	A 10-11-1993
US 5366469	A 22-11-1994			
EP 0255338	A	03-02-1988	AU 610832	B 30-05-1991
			AU 7622387	A 04-02-1988
			BR 8703901	A 05-04-1988
			US 4817603	A 04-04-1989
US 5569287	A	29-10-1996	JP 7213925	A 15-08-1995