



INTERNATIONAL APPLICATION PUBLISHED UNDER THE PATENT COOPERATION TREATY (PCT)

<p>(51) International Patent Classification ⁶ : A61F 2/08</p>	<p>A1</p>	<p>(11) International Publication Number: WO 00/18332</p> <p>(43) International Publication Date: 6 April 2000 (06.04.00)</p>
<p>(21) International Application Number: PCT/US99/22701</p> <p>(22) International Filing Date: 29 September 1999 (29.09.99)</p> <p>(30) Priority Data: 09/163,998 30 September 1998 (30.09.98) US</p> <p>(71) Applicant (for all designated States except US): BIONX IMPLANTS OY [FI/FI]; Hermiankatu 6-8 L, FIN-33720 Tampere (FI).</p> <p>(72) Inventors; and (75) Inventors/Applicants (for US only): TORMALA, Pertti [FI/FI]; Saarenkajenkujja 5 As. 2, FIN-33300 Tampere (FI). TASTO, James, P. [US/US]; Suite 200, 6719 Alvarado Road, San Diego, CA 92120 (US).</p> <p>(74) Agents: MAYER, Richard, L. et al.; Kenyon & Kenyon, One Broadway, New York, NY 10004 (US).</p>	<p>(81) Designated States: AU, CA, JP, US, European patent (AT, BE, CH, CY, DE, DK, ES, FI, FR, GB, GR, IE, IT, LU, MC, NL, PT, SE).</p> <p>Published <i>With international search report.</i></p>	

(54) Title: CHUTE FOR ENDOSTEAL LIGAMENT FIXATION

(57) Abstract

This invention is a bio-absorbable implant (1) for use in the endosteal fixation of a ligament (2), such as the cruciate ligaments. A method of drilling a hole (3) in a bone (6), and placing a ligament (2) into the hole (3) along with a chute (1), is included. The ligament (2) is attached with an anchoring device (5). The chute (1) has a structural design of a smooth edge (8), a jagged edge (9) where the smooth side lies against the ligament (2), and the jagged side against the bone (6).

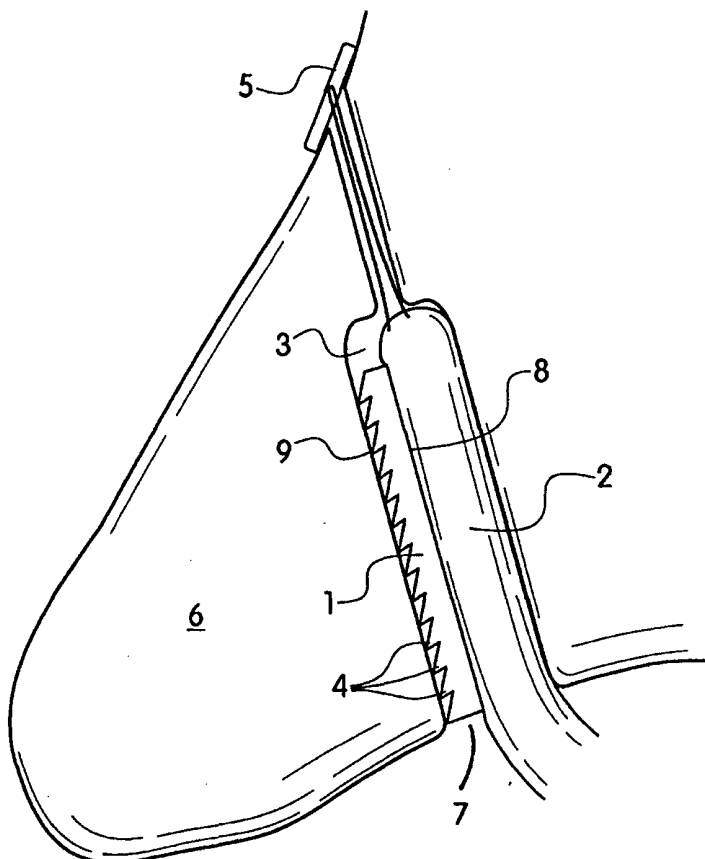

FOR THE PURPOSES OF INFORMATION ONLY

Codes used to identify States party to the PCT on the front pages of pamphlets publishing international applications under the PCT.

AL	Albania	ES	Spain	LS	Lesotho	SI	Slovenia
AM	Armenia	FI	Finland	LT	Lithuania	SK	Slovakia
AT	Austria	FR	France	LU	Luxembourg	SN	Senegal
AU	Australia	GA	Gabon	LV	Latvia	SZ	Swaziland
AZ	Azerbaijan	GB	United Kingdom	MC	Monaco	TD	Chad
BA	Bosnia and Herzegovina	GE	Georgia	MD	Republic of Moldova	TG	Togo
BB	Barbados	GH	Ghana	MG	Madagascar	TJ	Tajikistan
BE	Belgium	GN	Guinea	MK	The former Yugoslav Republic of Macedonia	TM	Turkmenistan
BF	Burkina Faso	GR	Greece			TR	Turkey
BG	Bulgaria	HU	Hungary	ML	Mali	TT	Trinidad and Tobago
BJ	Benin	IE	Ireland	MN	Mongolia	UA	Ukraine
BR	Brazil	IL	Israel	MR	Mauritania	UG	Uganda
BY	Belarus	IS	Iceland	MW	Malawi	US	United States of America
CA	Canada	IT	Italy	MX	Mexico	UZ	Uzbekistan
CF	Central African Republic	JP	Japan	NE	Niger	VN	Viet Nam
CG	Congo	KE	Kenya	NL	Netherlands	YU	Yugoslavia
CH	Switzerland	KG	Kyrgyzstan	NO	Norway	ZW	Zimbabwe
CI	Côte d'Ivoire	KP	Democratic People's Republic of Korea	NZ	New Zealand		
CM	Cameroon		Republic of Korea	PL	Poland		
CN	China	KR	Republic of Korea	PT	Portugal		
CU	Cuba	KZ	Kazakstan	RO	Romania		
CZ	Czech Republic	LC	Saint Lucia	RU	Russian Federation		
DE	Germany	LI	Liechtenstein	SD	Sudan		
DK	Denmark	LK	Sri Lanka	SE	Sweden		
EE	Estonia	LR	Liberia	SG	Singapore		

CHUTE FOR ENDOSTEAL LIGAMENT FIXATION

BACKGROUND OF THE INVENTION

This invention relates to the field of bioabsorbable implants and their methods of use.
5 More particularly, this invention relates to a bioabsorbable implant for use in the endosteal fixation of a ligament, such as the cruciate ligaments, and the methods for its use.

The tearing and degradation of the cruciate ligaments of the knee is a common and potentially painful and debilitating problem affecting thousands of people each year. Within the knee, cruciate ligaments serve the important purposes of maintaining the proper
10 positioning of the femur with respect to the tibia and the tibia plateau and preventing potentially dangerous rotation, hyperextension, or hyperflexion of the knee joint. Thus, the proper functioning of the cruciate ligaments is necessary to maintaining the proper stability and mobility of the knee joint.

Surgeons have struggled to be able to reconstruct or replace cruciate ligaments in such
15 a manner that the patient quickly regains the full range of motion and stability of the knee joint. Torn or damaged cruciate ligaments are commonly treated through the use of autografts - connective tissues, such as tendons or ligaments, which are transplanted from elsewhere in the patient and grafted onto the site of the originally damaged or torn cruciate ligament. Allograft tissue is also occasionally used in a variety of reconstructions.

20 There are several important factors that determine the success of an autograft used to replace a torn or damaged cruciate ligament. The autograft must be affixed to a location as near as possible to the location of the original cruciate ligament. Otherwise, the autograft will not function as the original cruciate ligament did and will not provide the necessary stability and movement control to the knee joint. The autograft must not be damaged during the

grafting process and must be able to quickly attach itself through the healing process to the bones to which it is grafted. Otherwise, during the post-operative rehabilitation period of the patient, the autograft may tear, stretch or separate from its fixation device and no longer serve as a proper replacement for the cruciate ligament. Further, the physical characteristics of the autograft should mirror those of the original cruciate ligament. These physical characteristics must be maintained over time and not degrade. Otherwise, the patient will eventually lose the stability and proper mobility of the knee joint and may require additional surgery to replace the autograft. For instance, the autograft must not stretch too much once attached, because this will cause looseness and a lack of stability in the joint.

Thus, there is a need for grafting techniques and apparatus that will achieve these results. Previous methods for attaching ligaments or autografts to bone have all suffered from various shortcomings. Initially, ligaments or autografts were attached directly to the surface of the bone with screws or staples. These methods, however, which puncture or severely compress the autograft, cause damage which can weaken the autograft. Further, these methods can lead to tearing or necrosis of the autograft. Additionally, these methods do not promote fast healing because of the relative lack of contact between the autograft and the bone. Also, in part because of the slow healing effected by these fasteners, they were often not made of bioabsorbable materials, which increased the risk of negative long-term reactions to the fasteners.

More recently, holes have been drilled in the bone through which the autograft is inserted and attached. Often, the autograft is attached to the bone using a suture anchor. This procedure, however, requires suturing the autograft to the suture anchor that is set in the bone. This is difficult to accomplish arthroscopically and can lead to tearing of the autograft when it

is subjected to stresses through the normal physical activities of the patient. Further, suture anchors often do not provide the strength needed to securely hold the ligament during the healing process. Additionally, the sutures themselves may fail.

Also, with suture anchors, and other techniques for fastening an autograft within a hole drilled into a bone, the hole is larger than the autograft segments in the hole. This causes several problems. First, the autograft is not pressed into solid contact with the bone, which slows the healing process. The autograft will most likely attach itself quickly and securely to the bone when as much of the autograft as possible is pressed securely against the bone surface. Second, the lack of good contact between the autograft and the bone causes the autograft to move around within the hole and at its entrance. This can damage the autograft, as well as cause a lack of stability in the knee joint. For optimal stability, the autograft must be tautly attached to the bone. It is particularly important to achieve good contact between the autograft and the bone at or near the entrance to the joint. This is referred to as strong aperture fixation. Third, as the portion of the autograft that is within the bone, but not securely affixed to the bone moves, it is more likely to stretch or suffer "creep" over time. This reduces the tautness of the autograft and the stability of the knee joint.

Some of these problems can be remedied with fixation apparatus that securely hold the autograft against the side of the hole drilled in the bone, at the entrance of the hole. For instance, screws have been used to securely hold autografts against the sides of the drill hole. The threads of the screw, however, often damage and cause necrosis in the autograft, which can hinder proper healing. Screws also unnecessarily reduce the surface area of the autograft that is exposed to the bone. Additionally, the insertion of the screw may inadvertently advance the autograft during insertion. To remedy the damage that screw threads cause to

autografts, other, bulkier, multi-part devices have been developed in which a screw does not directly press against the autograft, but rather presses against a second (or second and third) part of the device that in turn presses the autograft against the bones, as shown, for example, in United States Patent No. 5,632,748. Such multipart devices are more complicated and
5 costly to use than screws, however. Also, such devices do not maximize the surface area of the autograft that is in contact with the bone. Greater contact between the autograft and the bone promotes rapid healing and is, therefore, preferred.

Thus, there is still a need in the art for an effective, efficient, simple technique for attaching an autograft or ligament to bone or other hard tissue that promotes rapid, secure,
10 and sustained healing.

BRIEF SUMMARY OF THE INVENTION

It is an object of the present invention to provide a fixation device for aiding the rapid, secure, and sustained healing and attachment of connective tissue to bone or other hard tissue.

15 It is further an object of the present invention to provide a fixation device that will aid rapid, secure, and sustained healing and attachment of connective tissue to bone or other hard tissue by maximizing the available surface area of the bone that contacts the connective tissue.

20 It is further an object of the present invention to provide a fixation device that will aid rapid, secure, and sustained healing and attachment of connective tissue to bone or other hard tissue without damaging or causing necrosis in the connective tissue during the attachment procedure.

It is further an object of the present invention to provide a fixation device that will aid rapid, secure, and sustained healing and attachment of connective tissue to bone or other hard tissue and that may be used simply, quickly, and arthroscopically or in an open procedure.

5 It is further an object of the present invention to provide a fixation device that will aid rapid, secure, and sustained healing and attachment of connective tissue to bone or other hard tissue and that is easy to manufacture and has low cost.

It is further an object of the present invention to provide a fixation device that will aid rapid, secure, and sustained healing and attachment of connective tissue to bone or other hard tissue and that is bioabsorbable.

10 It is further an object of the present invention to provide a fixation device that will aid rapid, secure, and sustained healing and attachment of connective tissue to bone or other hard tissue and that has a high pullout strength of at least 50 MPa.

15 It is further an object of the present invention to provide a fixation device that will aid rapid, secure, and sustained healing and attachment of connective tissue to bone or other hard tissue and that will help prevent stretching or "creep" of the connective tissue after attachment.

It is further an object of the present invention to provide a fixation device that will aid rapid, secure, and sustained healing and attachment of connective tissue to bone or other hard tissue and that will create strong aperture fixation.

20 The foregoing objects, and others, have surprisingly been achieved with the present invention. The present invention is designed to aid the attachment of connective tissue, such as ligaments, to hard tissue, such as bone. In such an attachment procedure, a hole is drilled in the bone and the ligament is fed into the hole. Depending upon the length of ligament

used, the ligament may be folded upon itself in the hole so that a plurality of loops or segments of ligament are present in the hole. The device of the present invention, which will be referred to as a chute, is bioabsorbable and is inserted into the hole and pushes the ligament tightly against the side of the hole. This contact between the ligament and the bone promotes healing and strong attachment between the two. In a preferred embodiment of the present invention, the chute may be easily inserted into the hole, simply by pushing the chute into the hole by hand or with a simple arthroscopic or other surgical device. It is noted that the use of the present invention is useful in, but is not limited to, arthroscopic procedures. In yet another preferred embodiment of the present invention, the portion of the chute that abuts the bone contains barbs or spikes or other protrusions, which increase the pull out strength of the chute and prevents migration. In another preferred embodiment of the present invention, the portion of the chute that abuts the ligament does not contain barbs or spikes or other protrusions, so that the ligament is not damaged during the attachment process.

Although this specification refers to the attachment of "ligaments" or "autografts" to "bone," it should be understood that the present invention is useful for the attachment of any connective tissue or synthetic tissue (like bioabsorbable, fibrous polymeric ligaments) to hard tissue. For instance, the present invention could be easily used in allograft hamstring fixation, quadriceps tendon fixation, or even in a bone-tendon-bone method of fixation when the osseous component does not fit well into the canal.

20

BRIEF DESCRIPTION OF THE DRAWINGS

The invention will be more fully described in conjunction with the accompanying drawings wherein:

5 FIG. 1 is a cross sectional side view of an embodiment of the chute of the present invention after having been inserted in a patient.

FIG. 2 is a cross sectional top view of an embodiment of the chute of the present invention after having been inserted in a patient.

FIG 3 is a cross sectional top view of another embodiment of the chute of the present invention after having been inserted in a patient.

10 FIG 4 is a cross sectional top view of another embodiment of the chute of the present invention after having been inserted in a patient.

FIG 5 is a cross sectional top view of another embodiment of the chute of the present invention after having been inserted in a patient.

15 FIG. 6 demonstrates the attachment of a ligament within a patient without using the chute of the present invention.

DETAILED DESCRIPTION OF THE INVENTION

The chute of the present invention is designed to aid in the attachment of a ligament or other connective tissue to bone or other hard tissue. In a specific embodiment, the chute
20 securely presses a ligament against the bone to which it is being attached, without harming the ligament, in order to promote healing. First, a hole is drilled in the bone to which the ligament will be attached. The hole is created using standard techniques, whether it is inside out or outside in. To the extent possible, the drill hole should approximate the size of the

ligament or graft being used. However, this is not critical because the present invention will ensure strong connection between the ligament and the bone.

Next, the ligament is fed into the hole. The ligament may be harvested and prepared through any one of a number of known techniques. Often, it will be anchored at the base of the hole, using techniques that are known in the art, such as a screw and washer or staple or sutures through the tendon attached to a screw. FIG. 6 demonstrates the ligament as it is attached in the prior art without using the chute of the present invention. It can be seen in FIG. 6 that a hole 3 has been drilled in the bone 6. The ligament 2 has been attached to an anchor 5 that is set in the base of the hole. It should be noted that the drill hole 3 is larger than the ligament 2. Thus, the ligament 2 can move around from one side of the hole 3 to the other, as it is pulled in various directions during the ordinary physical activities of the patient. This movement of the ligament is shown in FIG. 6. The position of the ligament 2 could occur, for instance, if the joint were in flexion. However, if the joint were in extension, the ligament 2 would be pulled to the other side of the entrance 7 to the hole 3. Thus, the ligament would be in the position of ligament 2a, drawn in dotted lines.

This motion of the ligament 2 within the hole 3 has several negative consequences. First, this motion prevents the ligament 2 from maintaining good contact with any part of the bone 6. Such contact is important in promoting proper long-term attachment of ligament to bone. Without good contact between the bone and the ligament, the healing process takes longer, and the ligament is not as strongly attached to the bone. Second, the motion of the ligament 2 at the edge 7 of the hole 3 can cause damage or irritation to the ligament 2 as it rubs against the edge 7. This damage can be serious enough to cause a complete failure of the attachment, requiring additional ligament replacement surgery. Third, this motion of the

ligament 2 exacerbates the problems associated with the stretching or "creep" of the ligament 2 over time. Once ligaments are attached to a bone and are subject to the cyclical stresses that occur through the normal activities of the patient, they tend to stretch. This causes the ligaments to become less taut and therefore reduces the stability of the joint. It is important to maintain the long-term tautness of the ligament after it has been attached to the bone, so that stability in the joint is maintained. Fourth, the stresses that are placed on the ligament 2 are passed directly through to the portion of the ligament 2 attached to the anchor 5. Depending upon the manner in which the ligament 2 is attached to the anchor 5, this can result in the tearing of the ligament 2 at the point where it is attached to the anchor 5 or sutures tearing through the ligament 2. Such a failure of the ligament 2 would require another replacement or reattachment operation.

With reference to FIG. 1, it can be seen how the chute 1, an embodiment of the present invention, solves these problems. When inserted into the hole 3, the chute 1 presses against the ligament 2, forcing it into close, secure contact with the bone 6. The length of the chute 1 used in a particular case may vary, so that there is strong contact along the length of the hole 3, including its aperture. As explained above, this contact promotes rapid healing and strong attachment of the ligament 2 to the bone 6. With the chute 1 in place, the ligament 2 may not move around within the hole 3. Thus, there is no risk of damage to the ligament 2 caused by its rubbing against the edge of the hole 3. Further, the amount of stretch or creep in the ligament is reduced because the portion of the ligament 2 that is in contact with the chute 1 is held securely in place and is not allowed to stretch. Additionally, the pressure of the chute 1 against the ligament 2 prevents the stresses placed on the ligament 2 from being transferred to the point where the ligament 2 is attached to the anchor 5. The chute 1, by

preventing the movement of a long section of the ligament 2, at least partially shields from stresses the portion of the ligament 2 that is attached to the anchor 5. This prevents damage to the ligament 2 at the point of attachment.

5 The particular method of insertion will vary, depending upon the nature of the reconstruction being performed. The chute of the present invention may be inserted by hand or with a surgical tool.

In one embodiment of the present invention, the portion 8 of the chute 1 that contacts the ligament 2 is relatively smooth and devoid of protuberances. Often, when pointed objects are placed in close contact with ligaments, they cause point necrosis in the ligament. The relative smoothness of the portion 8 of the chute 1 that contacts the ligament 2 helps to prevent such necrosis from occurring. The relative smoothness of the portion 8 of the chute 1 also facilitates easy insertion of the chute, with no damage to the ligament 2. It is always beneficial to reduce the amount of time needed to complete surgery. Thus, devices that may be easily used are always in demand. The ability of the chute 1 to be inserted simply by pushing it into the hole 3 makes it particularly useful.

In another embodiment of the present invention, the portion 9 of the chute 1 that contacts the bone 6, contains protrusions, such as barbs, ridges, scales, etc. that resist movement of the chute 1 towards the edge 7 of the hole 3. This tends to increase the pull out strength of the chute 1. The protrusions are configured, however, so that they do not prevent the chute 1 from being easily inserted by merely pushing it into the hole 3.

The chute of the present invention can have a variety of different cross sections, depending upon the number and size of the ligament segments that are being pressed against the bone. Depending on the amount of ligament available, several segments of ligament may

be looped through the hole in the bone. In all cases, the cross section of the chute 1 is designed to maximize the surface area contact between the ligaments 2 and the bone 6. FIG. 2, FIG. 3 and FIG 4 show cross sections for additional embodiments of the present invention. In FIG. 2, the ligament 2 takes up most of the space of the hole 3. Thus, the chute 1 has a relatively small cross sectional area. In FIG. 3, the chute 1 has a larger cross sectional area because the ligament 2 takes up less space in the hole 3. In FIG. 4, the chute 1 has an even larger cross sectional area because the ligament 2 takes up even less space in the hole 3. In FIG. 4, the cross section is designed so that a ridge 10 in the chute 1, does not contact the bone 6. Instead, the ridge 10 pushes a greater surface area of the ligament 2 against the bone 6, thereby promoting better healing and attachment between the bone 6 and the ligament 2.

FIG. 5 shows a cross section for an additional embodiment of the chute of the present invention to be used when there are four segments of ligament 2 looped in the hole 3. The chute 1 has four ridges 11, the ends of which contact the bone 6. In another embodiment of the present invention, each of the ridges 11 may have barbs or other protrusions 12, which resist removal of the chute 1 once it is inserted into the hole 3. The geometry of chute 1 is such that the majority of the surface area of the bone 6 is in secure contact with the ligament 2, not the chute 1. This feature promotes rapid and secure healing and attachment of the ligament 2 to the bone 6.

It will be readily apparent that the cross section of the chutes can be further altered, depending on the size and number of the connective tissue segments in the hole, without departing from the scope of the present invention.

The chutes of the present invention are bioabsorbable and can be prepared from known bioabsorbable polymers, using techniques that are well known in the art for preparing

such polymeric rods, plates, profiles, etc., such as injection molding and extrusion, and the chutes also can be prepared from oriented, fibrillated bioabsorbable polymers in accordance with the techniques described in U.S. Patent No. 4,968,317, the entire disclosure of which is incorporated herein by way of this reference. These and other known techniques for

5 preparing the bioabsorbable rods of the invention will be apparent to those of ordinary skill in the art. Since the chutes are bioabsorbable, as the ligaments become more strongly attached to the bone over time, the chutes degrade into harmless byproducts. In contrast, nonbioabsorbable implants can partially degrade into harmful products, thereby causing irritation or rejection by the tissue surrounding the implant. Also, at times nonbioabsorbable

10 implants must be removed, requiring a second surgical procedure. Further, nonbioabsorbable implants can obscure the surrounding tissue, making it difficult to view, for instance with X-rays or MRI scanners. These problems are avoided by using a bioabsorbable chute.

According to an advantageous embodiment of the invention, the chutes which have a substantial contact surface with bone (like, e.g., the chutes of FIGS. 1-4) can contain open

15 porosity or holes which penetrate the chute. The diameter of the pores or holes can typically be between about 100 μm -2000 μm . Such pores or holes help bone tissue and/or connective tissue to grow through the chute to create tissue-ligament contact through the chute even before the biosorption of the chute has occurred.

The chutes of the present invention can be manufactured of thermoplastic

20 bioabsorbable (resorbable or biodegradable) polymers, copolymers, polymer alloys, or composites e.g. of poly- α -hydroxy acids and other aliphatic bioabsorbable polyesters, polyanhydrides, polyorthoesters, polyorganophosphazenes, tyrosine polycarbonates and other known bioabsorbable polymers disclosed in numerous publications, e.g. in S. Vainiopää

et al., Prog. Polym. Sci., 14 (1989) 679-716, FI Pat. No. 952884, FI Pat. No. 955547 and WO-90/04982, EP 0449867 B1, US Pat. No. 5,569,250, S.I. Ertel et al., J. Biomed. Mater. Res., 29 (1995) 1337-1348, the entire disclosures of each of which are incorporated herein by way of this reference, as well as in the reference publications mentioned in the
5 aforementioned publications.

Implants in accordance with the present invention may be manufactured of bioabsorbable polymers by using one polymer or a polymer alloy. The implants can also be reinforced by reinforcing the material by fibers manufactured of a resorbable polymer or of a polymer alloy, or with biodegradable glass fibers, such as β -tricalciumphosphate fibres,
10 bioactive glass fibers, CaM fibers, using techniques that are known to those of ordinary skill in the art, as described in EP146398, the entire disclosure of which is incorporated herein by way of this reference. Ceramic and bioactive glass powders may also be used as additives (fillers) in the implants of the present invention to promote new bone formation. Bioactive glass or ceramic fillers and/or fiber reinforcement useful in making the polymeric chutes of
15 the invention also are described e.g. in M. Brink "Bioactive Glasses with a Large Working Range" Doctoral Thesis Åbo Akademi University, Turku, Finland, 1997 and M. Marcolongo et al. J. Biomed. Mater. Res. 39 (1998), and in US Pat. No. 4,612,923, the entire disclosures of each of which are incorporated herein by way of this reference.

The materials and implants of the present invention may also contain various
20 additives for facilitating the processability of the material (e.g. stabilizers, antioxidants or plasticizers) or for changing its properties (e.g. plasticizers or ceramic powder materials or biostable fibers, such as carbon) or for facilitating its treatment (e.g. colorants).

According to one advantageous embodiment, the implant of the present invention contains a bioactive agent or agents, such as antibiotics, chemotherapeutic agents, agents activating healing of wounds, growth factor(s), bone morphogenic protein(s), anticoagulants (such as heparin), etc. Such bioactive implants are particularly advantageous in clinical use, because they have, in addition to their mechanical effect, also biochemical, medical and other effects to facilitate tissue healing and/or regeneration.

After the description above of the present invention and certain specific embodiments thereof, it will be readily apparent to those skilled in the art that many variations and modifications may be made to the present invention without departing from the spirit and scope thereof.

We claim:

1. A one-piece bioabsorbable chute for pressing connective tissue against the side of a hole drilled into bone, said chute comprising an outer surface, a portion of said outer surface being configured to press against said connective tissue without causing damage to said
5 tissue, the remaining portion of said outer surface being configured to press against said bone.
2. The bioabsorbable chute of claim 1, wherein said chute is capable of being held in place in said hole through an interference fit among said bone and said connective tissue.
- 10 3. The bioabsorbable chute of claim 1, wherein the portion of said surface being configured to press against said bone contains at least one protrusion, said protrusion being configured to resist the removal of said chute from said hole.
4. The bioabsorbable chute of claim 3, wherein the protrusion is in the form of a barb.
15
5. The bioabsorbable chute of claim 3, wherein the protrusion is in the form of a scale.
6. The bioabsorbable chute of claim 3, wherein the chute has a pull out strength of at least 50 MPa.
20
7. The bioabsorbable chute of claim 3, wherein said surface being configured to press against said connective tissue is larger than said surface being configured to press against said bone.

8. The bioabsorbable chute of claim 3, wherein said chute has a longitudinal direction and at least one ridge that runs along said longitudinal direction, said ridge being configured to press against said connective tissue.
- 5 9. The bioabsorbable chute of claim 1, wherein said chute has pores penetrating the chute.
10. The bioabsorbable chute of claim 9, wherein the pores have a diameter between 100 μm and 2000 μm .
- 10 11. The bioabsorbable chute of claim 10, wherein the surface being configured to press against said connective tissue is smooth.
12. A method for attaching connective tissue to bone comprising:
drilling a hole in the bone;
anchoring at least one end of one segment of said connective tissue to said hole;
inserting into said hole the one-piece bioabsorbable chute of claims 1 for securely pressing said ligament against said bone.

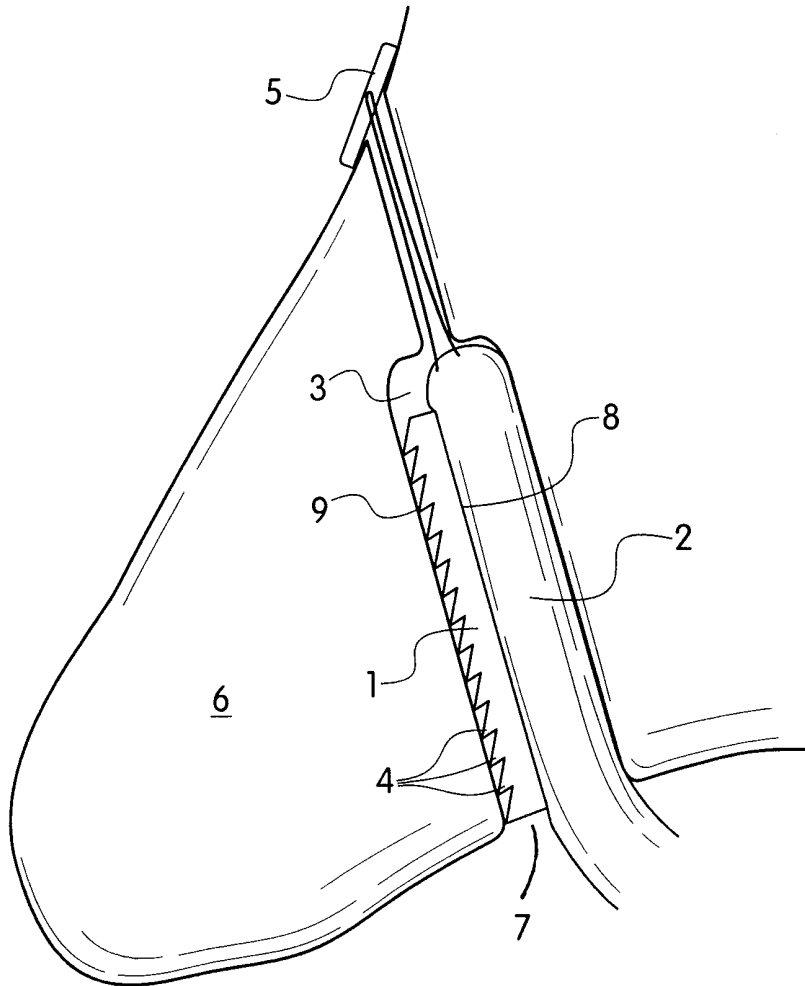

FIG. 1

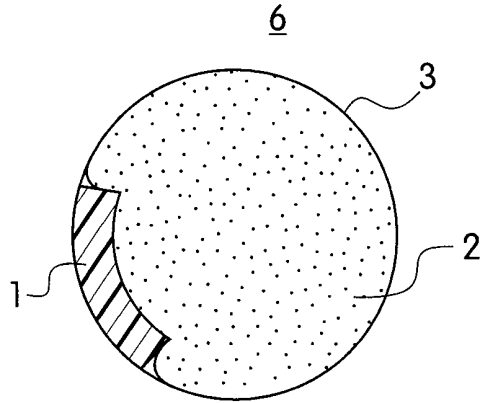

FIG. 2

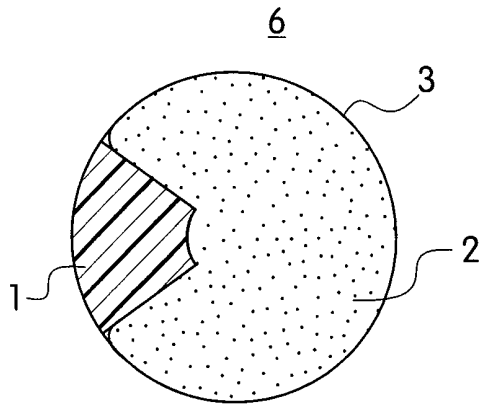

FIG. 3

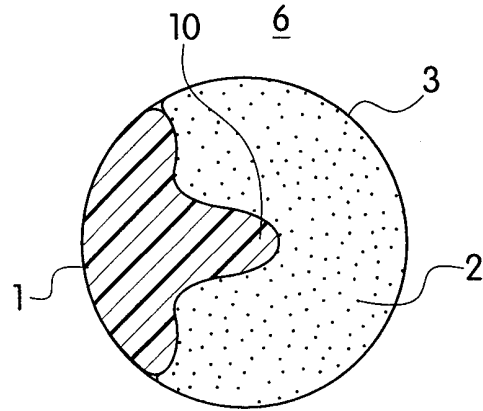

FIG. 4

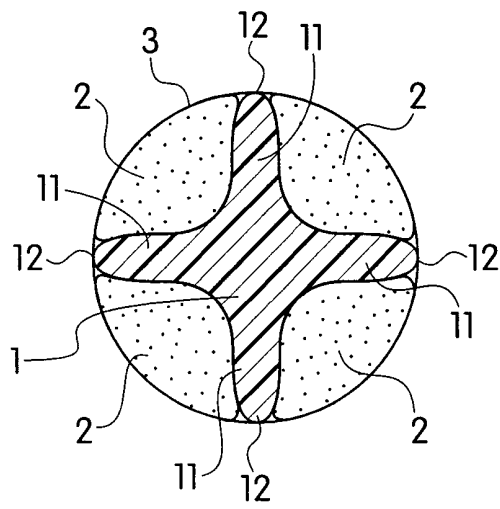

FIG. 5

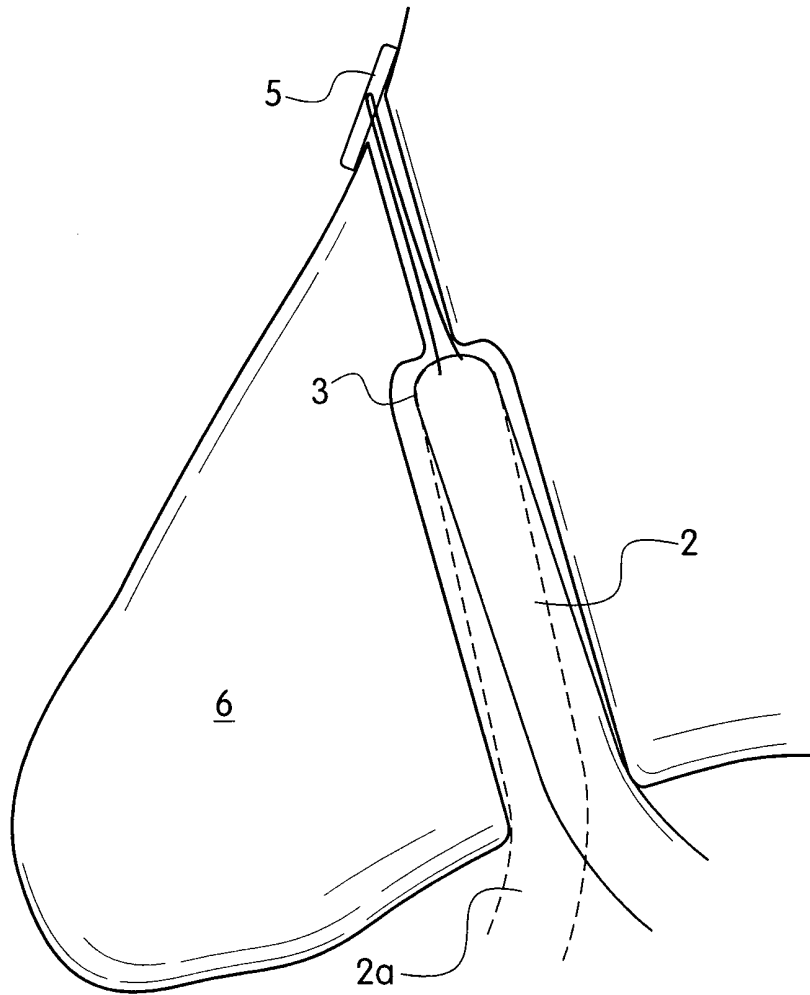

FIG. 6

INTERNATIONAL SEARCH REPORT

International application No.
PCT/US99/22701

A. CLASSIFICATION OF SUBJECT MATTER
IPC(6) :A61F 2/08
US CL :623/13
According to International Patent Classification (IPC) or to both national classification and IPC

B. FIELDS SEARCHED
Minimum documentation searched (classification system followed by classification symbols)
U.S. : 623/11, 13

Documentation searched other than minimum documentation to the extent that such documents are included in the fields searched

Electronic data base consulted during the international search (name of data base and, where practicable, search terms used)
WEST, EAST
Search Terms: endosteal fixation, anchor with pores

C. DOCUMENTS CONSIDERED TO BE RELEVANT

Category*	Citation of document, with indication, where appropriate, of the relevant passages	Relevant to claim No.
Y,P	US 5,931,869 A (BOUCHER et al.) 03 August 1999, Figs. 10, 12, 13, and all of disclosure.	1-8, 12
Y,P	US 5,961,520 A (BECK, JR. et al.) 05 October 1999, col. 6 lines 38-48, and col. 11 lines 31-33.	1-12
Y	US 5,454,811 A (HUEBNER) 03 October 1995, Fig. 5, col.2 lines 32-40, and col. 3 lines 29-56.	1-8, 12
Y	US 4,255,820 A (ROTHERMEL et al.) 17 March 1981, col. 2 lines 43-48.	9-11

Further documents are listed in the continuation of Box C. See patent family annex.

* Special categories of cited documents:	"T" later document published after the international filing date or priority date and not in conflict with the application but cited to understand the principle or theory underlying the invention
"A" document defining the general state of the art which is not considered to be of particular relevance	"X" document of particular relevance; the claimed invention cannot be considered novel or cannot be considered to involve an inventive step when the document is taken alone
"E" earlier document published on or after the international filing date	"Y" document of particular relevance; the claimed invention cannot be considered to involve an inventive step when the document is combined with one or more other such documents, such combination being obvious to a person skilled in the art
"L" document which may throw doubts on priority claim(s) or which is cited to establish the publication date of another citation or other special reason (as specified)	"&" document member of the same patent family
"O" document referring to an oral disclosure, use, exhibition or other means	
"P" document published prior to the international filing date but later than the priority date claimed	

Date of the actual completion of the international search 24 NOVEMBER 1999	Date of mailing of the international search report 19 JAN 2000
---	--

Name and mailing address of the ISA/US Commissioner of Patents and Trademarks Box PCT Washington, D.C. 20231 Facsimile No. (703) 305-3230	Authorized officer: <i>Brian Pellegrino</i> BRIAN PELLEGRINO Telephone No. (703) 306-5899
--	--