



US 20040166797A1

(19) **United States**

(12) **Patent Application Publication**

Thrasher et al.

(10) **Pub. No.: US 2004/0166797 A1**

(43) **Pub. Date: Aug. 26, 2004**

(54) **ELECTRICALLY ISOLATED SYSTEMS,
METHODS AND DEVICES FOR
CONTROLLING VENTILATION REGISTERS**

Related U.S. Application Data

(60) Provisional application No. 60/444,409, filed on Feb. 3, 2003.

(76) Inventors: **Steven Thrasher**, Richardson, TX (US); **Bryan A. Scott**, Plano, TX (US); **John Bugg**, Dallas, TX (US)

Publication Classification

(51) **Int. Cl.⁷ F24F 13/08**

(52) **U.S. Cl. 454/290; 454/299; 454/325**

Correspondence Address:

Steven Thrasher
391 Sandhill Dr.
Richardson, TX 75080 (US)

(57) **ABSTRACT**

The invention teaches and shows systems, devices and methods for controlling the automation of ventilation registers. In one embodiment, the invention is a system for articulating a register for a heating or air-conditioning system. The system generally includes a local power source, a means for receiving a wireless signal, a means for switching a drive means on, a drive means, and a movable member.

(21) Appl. No.: **10/772,954**

(22) Filed: **Feb. 3, 2004**

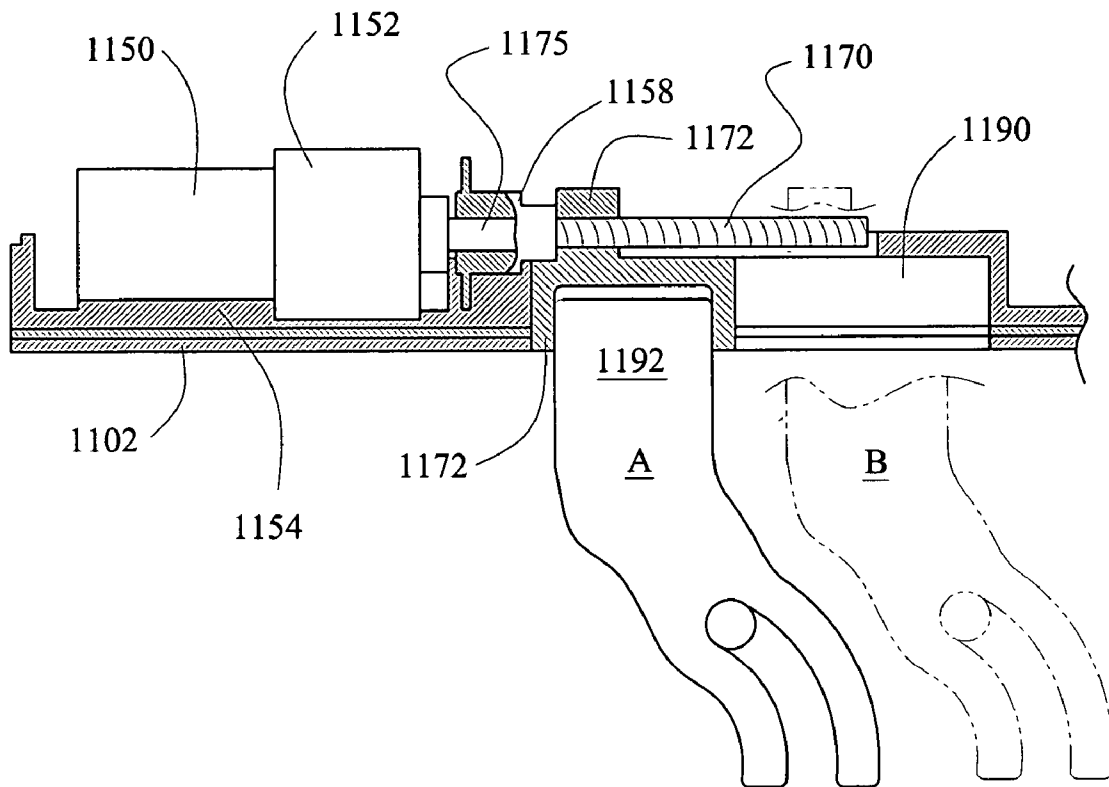

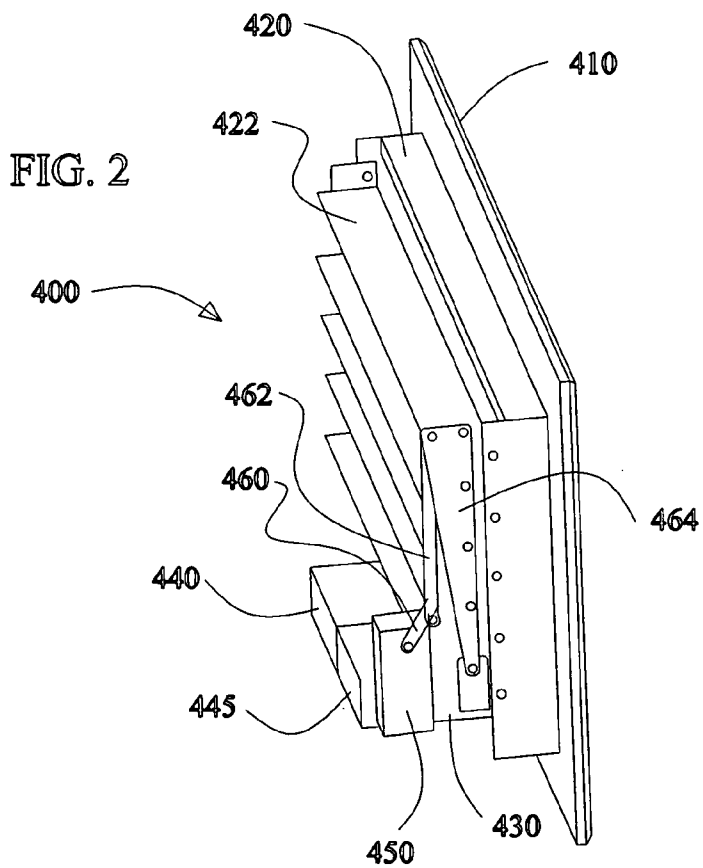
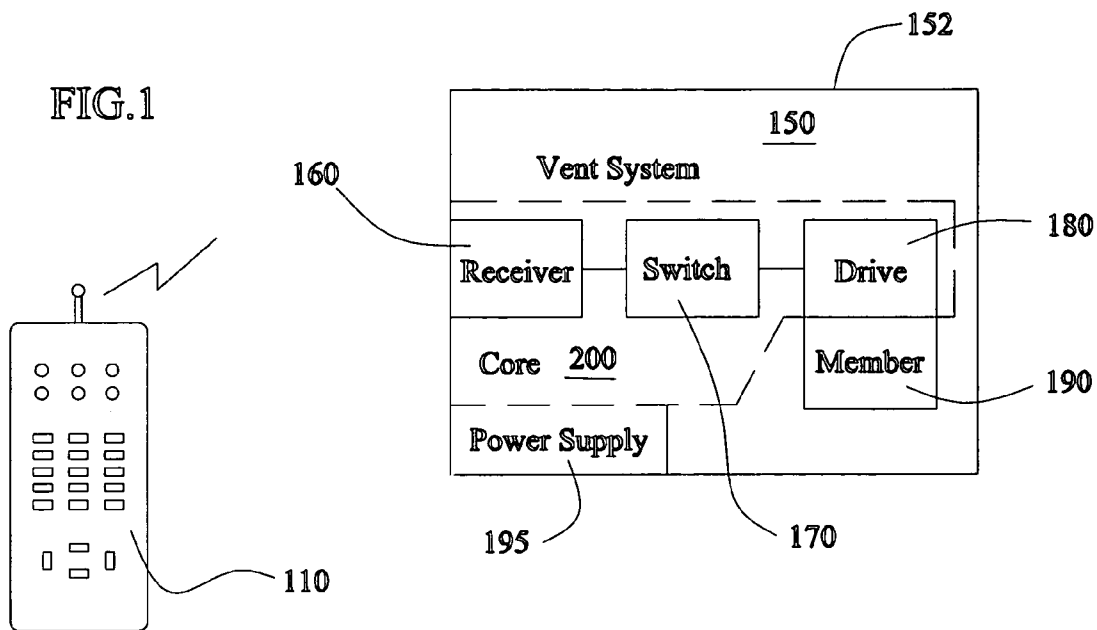
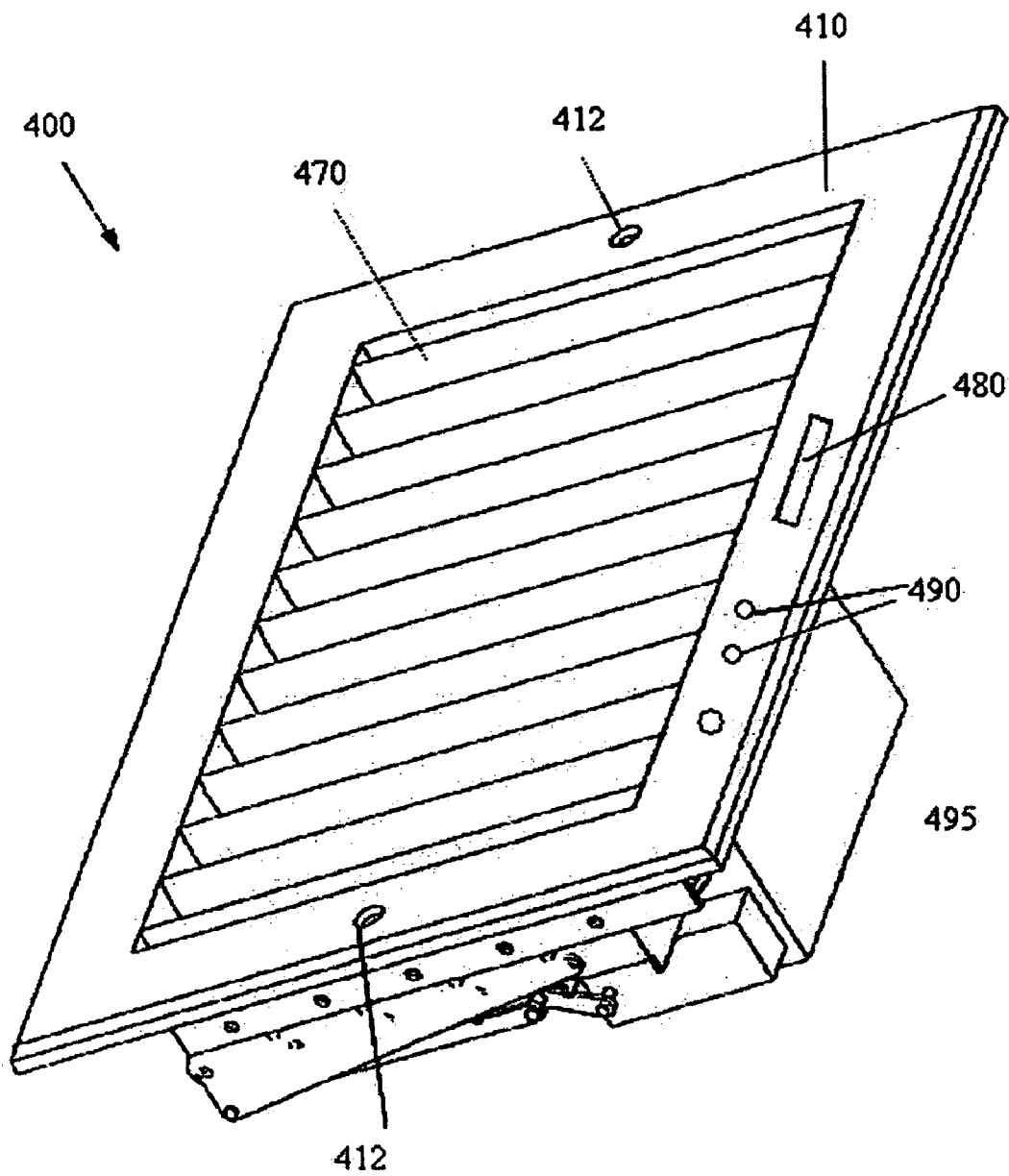

FIG. 3



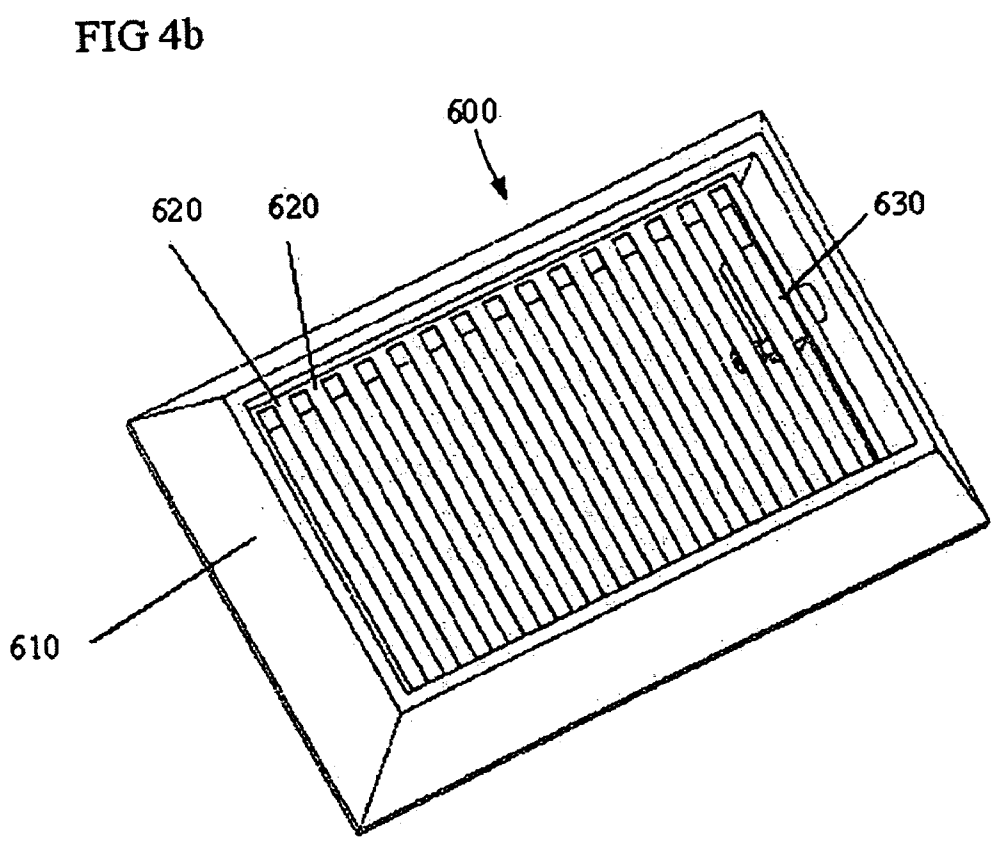
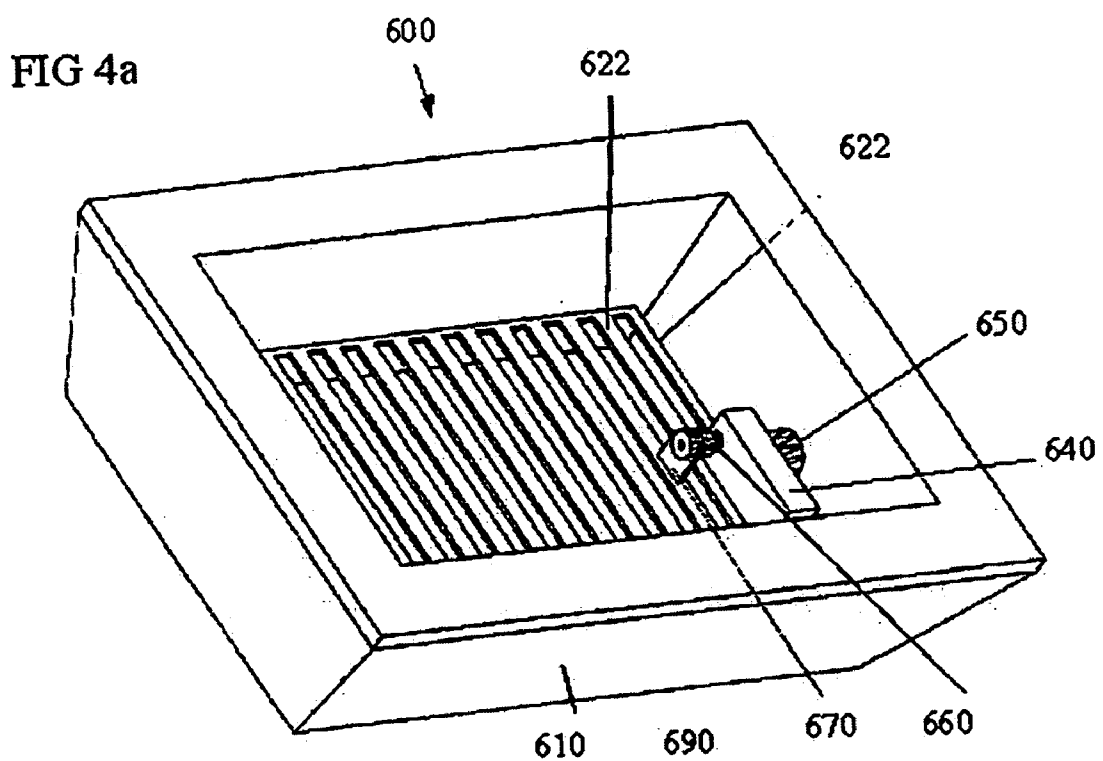
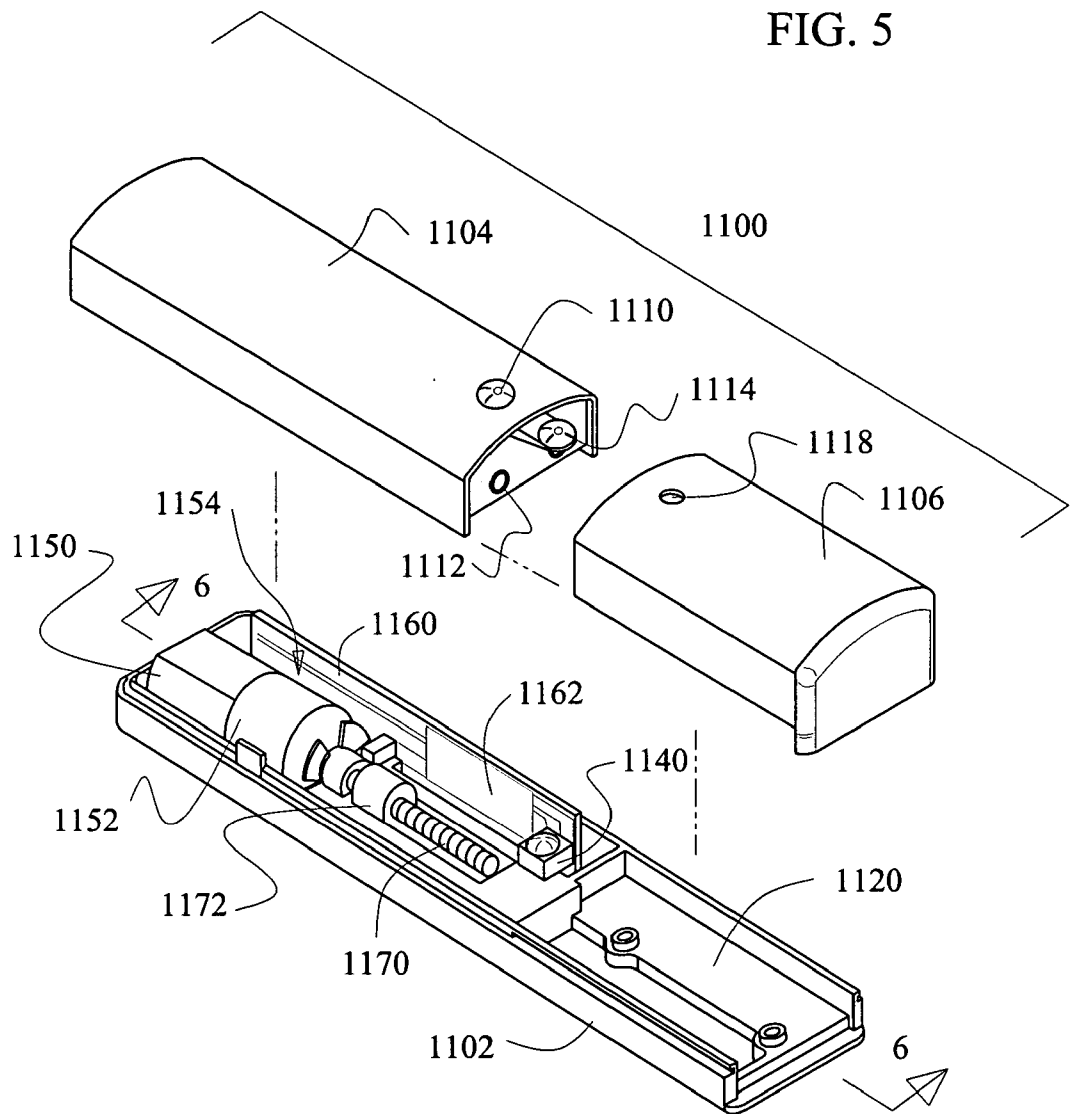

FIG. 5



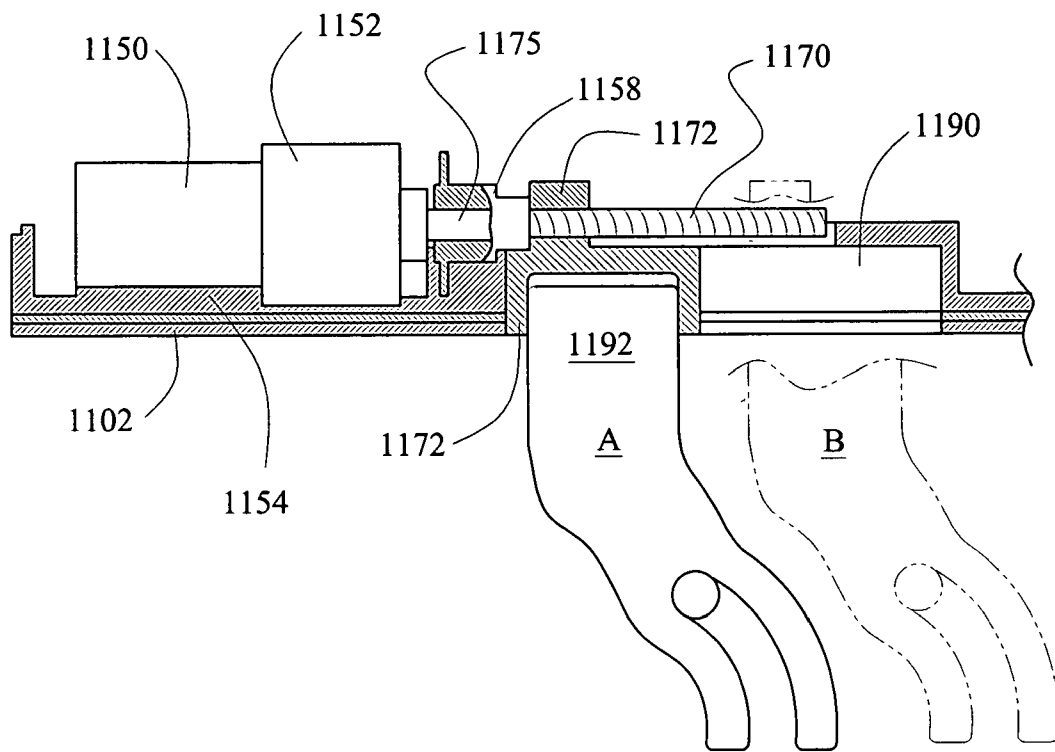
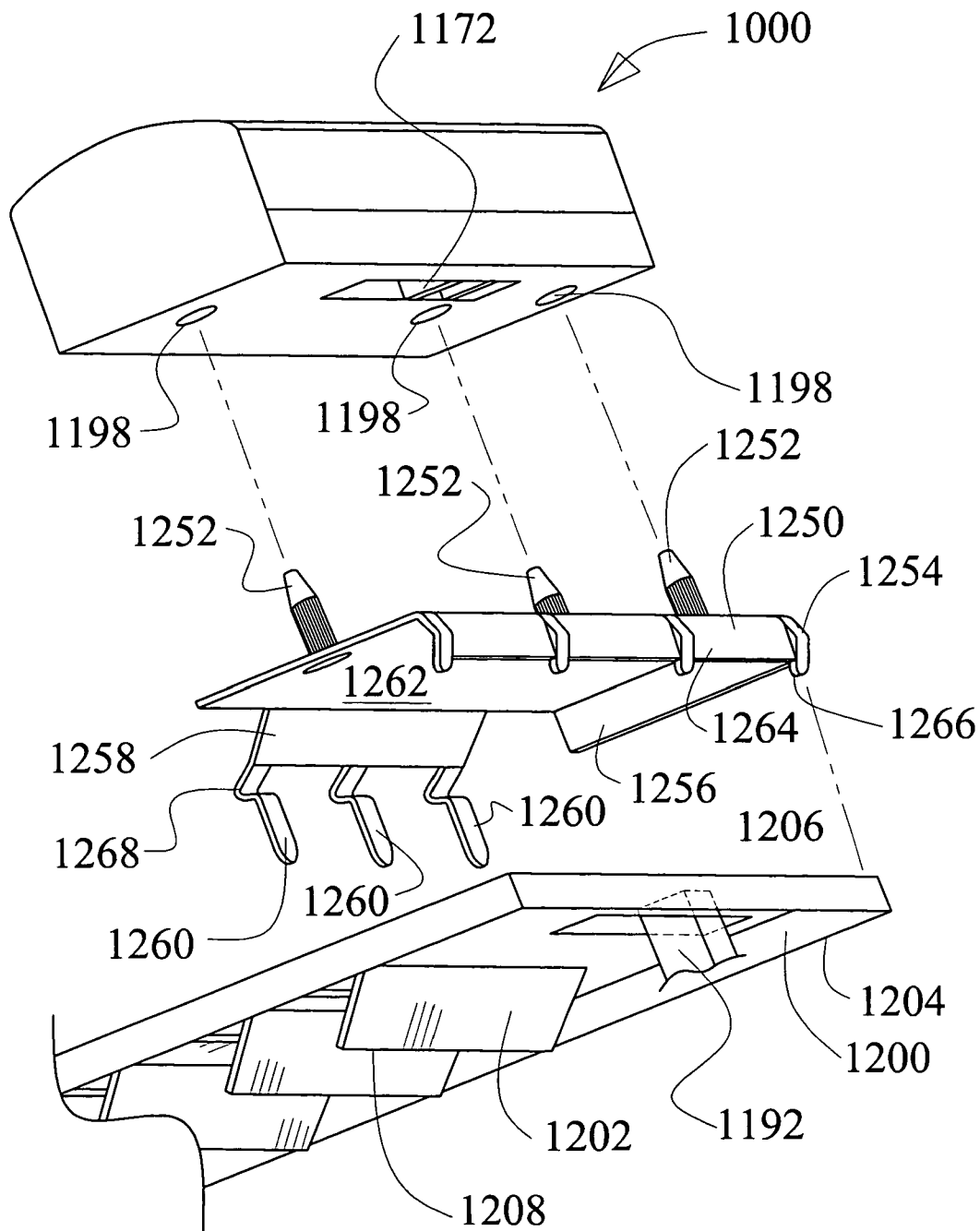

FIG. 6

FIG. 7



**ELECTRICALLY ISOLATED SYSTEMS, METHODS
AND DEVICES FOR CONTROLLING
VENTILATION REGISTERS**

RELATED APPLICATION

[0001] This invention is related to and claims priority from U.S. Provisional Patent Application No. 60/444,409 to Thrasher, et al., filed on 3 Feb. 2003.

TECHNICAL FIELD OF THE INVENTION

[0002] The invention relates generally to the field of home and office automation, and, more specifically, the invention relates to remotely controlling the actuation of a register.

**STATEMENT OF A PROBLEM ADDRESSED BY
THIS INVENTION**

[0003] Interpretation Considerations

[0004] This section describes the technical field in more detail, and discusses problems encountered in the technical field. This section does not describe prior art as defined for purposes of anticipation or obviousness under 35 U.S.C. section 102 or 35 U.S.C. section 103. Thus, nothing stated in the Statement of a Problem Addressed by This Invention is to be construed as prior art.

[0005] Discussion

[0006] Many persons (particularly those who are physically challenged) may not be able to operate traditional ventilation registers. Other persons may not be able to operate ventilation registers because they are difficult to reach, such as when a register is located in a high ceiling. Accordingly, there are benefits to be realized from making it easier to operate ventilation registers. The present invention provides such devices, systems and methods.

BRIEF DESCRIPTION OF THE DRAWINGS

[0007] Various aspects of the invention, as well as at least one embodiment, are better understood by reference to the following EXEMPLARY EMBODIMENT OF A BEST MODE. To better understand the invention, the EXEMPLARY EMBODIMENT OF A BEST MODE should be read in conjunction with the drawings in which:

[0008] FIG. 1 illustrates one embodiment of a home automation system and core according to the present invention;

[0009] FIG. 2 provides one embodiment of a vent for a heating or air-conditioning system;

[0010] FIG. 3 provides a front view of the register shown in FIG. 2;

[0011] FIG. 4a provides one embodiment of a vent cover for a heating or air-conditioning system;

[0012] FIG. 4b is a front view of an alternative embodiment of a vent cover for a heating or air-conditioning system;

[0013] FIG. 5 illustrates one embodiment of a preferred housing;

[0014] FIG. 6 is a cut view of FIG. 5 taken along cut line 6-6; and

[0015] FIG. 7 shows one alternative means for coupling a housing to a register via an adapter.

**AN EXEMPLARY EMBODIMENT OF A BEST
MODE**

[0016] Interpretation Considerations

[0017] When reading this section (An Exemplary Embodiment of a Best Mode, which describes an exemplary embodiment of the best mode of the invention, hereinafter "exemplary embodiment"), one should keep in mind several points. First, the following exemplary embodiment is what the inventor believes to be the best mode for practicing the invention at the time this patent was filed. Thus, since one of ordinary skill in the art may recognize from the following exemplary embodiment that substantially equivalent structures or substantially equivalent acts may be used to achieve the same results in exactly the same way, or to achieve the same results in a not dissimilar way, the following exemplary embodiment should not be interpreted as limiting the invention to one embodiment.

[0018] Likewise, individual aspects (sometimes called species) of the invention are provided as examples, and, accordingly, one of ordinary skill in the art may recognize from a following exemplary structure (or a following exemplary act) that a substantially equivalent structure or substantially equivalent act may be used to either achieve the same results in substantially the same way, or to achieve the same results in a not dissimilar way. In addition, statements that an aspect or element of the invention is obvious to one of ordinary skill in an art is applicable to only that specific art, and no other including the art of the invention, unless otherwise indicated.

[0019] Accordingly, the discussion of a species (or a specific item) invokes the genus (the class of items) to which that species belongs as well as related species in that genus. Likewise, the recitation of a genus invokes the species known in the art. Furthermore, it is recognized that as technology develops, a number of additional alternatives to achieve an aspect of the invention may arise. Such advances are hereby incorporated within their respective genus, and should be recognized as being functionally equivalent or structurally equivalent to the aspect shown or described.

[0020] Second, the only essential aspects of the invention are identified by the claims. Thus, aspects of the invention, including elements, acts, functions, and relationships (shown or described) should not be interpreted as being essential unless they are explicitly described and identified as being essential. Third, a function or an act should be interpreted as incorporating all modes of doing that function or act, unless otherwise explicitly stated (for example, one recognizes that "tacking" may be done by nailing, stapling, gluing, hot gunning, riveting, etc., and so a use of the word tacking invokes stapling, gluing, etc., and all other modes of that word and similar words, such as "attaching"). Further, the discussion herein incorporates all known and foreseeable embodiments of the below-discussed devices, systems, apparatuses, means, and methods. Although modifications to this application may be required by the patent office, no such modifications are wavers of the doctrine of equivalents, or any other rights to equivalents in the invention. Fourth, unless explicitly stated otherwise, conjunctive words (such as "or", "and", "including", or "comprising" for example)

should be interpreted in the inclusive, not the exclusive, sense. Fifth, the words “means” and “step” are provided to facilitate the reader’s understanding of the invention and do not mean “means” or “step” as defined in §112, paragraph 6 of 35 U.S.C., unless used as “means for-functioning-” or “step for-functioning-” in the claims section. The invention is also described in view of the Festo decisions, and, in that regard, the claims and the invention incorporate equivalents known, foreseeable, and unforeseeable.

DISCUSSION OF THE FIGURES

[0021] Features and advantages of the invention can be better understood by reviewing **FIG. 1**, which illustrates a system for controlling a ventilation register (the vent system) **150**. The system includes a remote control **110** that communicates wirelessly with the vent system **150**. The remote control **110** may operate through infrared or radio wave signals, such as home RF, or an IEEE 802.11 standard. In addition, the remote control **110** is preferably a hand held remote control or a remote control that is affixed to a surface, such as a wall of a home. In one embodiment, the remote control **110** is any standard remote control device that may operate a second appliance, such as a television, radio, or VCR, for example.

[0022] Accordingly, the vent system **150** may be adjusted to respond to the remote control **110** by specifically programming the vent system **150** to respond when a second device command is received, by programming the vent system **150** to respond when any of a family of second device signals are received, or to respond when any signal, above some predetermined strength, is received. This provides particular utility when a vent system **150** may be designed to respond to any infrared signal (a “don’t care” command/condition) such that any remote control device may operate the vent system **150** based on a sequence of inputs received from a remote control **110**.

[0023] The vent system **150** may be integrated with a ventilation register, or may be separate from a ventilation register and then attached to the ventilation register for operation. The vent system **150** generally includes a receiver **160**, which receives the wireless signals from the remote control **110**. The receiver **160** is generally characterized in one embodiment as any device capable of, or in an alternative embodiment, a means for receiving, a wireless communication, such as an infrared receiver, or a radio antenna (embedded or exterior), for example. In addition, the receiver **160** may also be characterized as any collection of electronics used to convert the received signal into a signal that can be processed by a switch or other logic, and may include a photodiode, as is known in the art.

[0024] Coupled to the receiver **160** is a switch **170** that converts reception indications from the receiver **160** into control signals and other signals needed to articulate and otherwise control a drive **180**, which may include components such as a motor, gears, and other mechanics as is known in the motor arts. Accordingly, a drive **180** is in one embodiment a means for generating a mechanical movement capable of articulating a member **190**. The switch may include remote control codes, memory, voltage regulating means, and/or logic such as a digital signal processor, for example. Upon reading this application, it is apparent to those of ordinary skill in the electrical engineering control

system arts that other variations of the switch are possible, and that the switch may be characterized as any means for articulating a drive based on an input command whether initiated remotely or via a direct user input.

[0025] The drive **180** may comprise a direct current or alternating current motor and is in one embodiment a controllable motor, such as a step-position (or multi-position) motor. For example, the drive **180** maybe a multi-position motor that is capable of having a drive shaft that is positionable based on input signals received from the switch **170** (such as at pre-determined angles, preferably 90°, 45°, 180°, 270°, and 360°). In alternative embodiments, the drive **180** maybe embodied as a worm-screw drive based motor, or as an electromechanical switch capable of being positioned via magnetic waves into a plurality of positions. In addition, the drive may be embodied as a micro-motor, and have coupled thereto a gearbox to turn a member **190** at a desired torque or at a desired rotational velocity. Upon reading this disclosure, other motor options will be readily apparent to those of the motor arts.

[0026] The drive **180** may be adapted to articulate a member **190** that is coupled to the drive **180**. The member **190** may be embodied as a mechanical or electrical system, and may comprise multiple mechanical or electrical parts. For example, the member **190** maybe embodied as a baffle on an ventilation register, as a worm-screw coupled to a ventilation register baffle, as an arm coupled to a baffle on a ventilation register or as a slide mechanism on a ventilation register. In addition, the drive **180** may be adapted to articulate a member **190** that is an integral part of a ventilation register, such as a flap of a ventilation register. Further, the member **190** may be embodied as an electromechanical solenoid switch. In **FIG. 1**, the drive **180** and the member **190** are shown as integrated boxes because in some applications, the line between the drive and the member may drawn quite arbitrarily. Upon reading this disclosure, other types of members will be readily apparent to those of mechanical skill in the ventilation register art.

[0027] Preferably, a housing **152** is adapted to attach to a ventilation register, and also adapted to maintain at least the receiver **160**, the switch **170**, and the drive **180**. Such adaptation may be achieved mechanically, or magnetically, for example. In one embodiment, the housing is adapted to attach to a ventilation register with an adapter (not shown in **FIG. 1**). Such an adapter may have a first side that substantially takes the shape of the housing **152**, and then have a second side that is specifically adapted to couple to a predetermined ventilation register type. Thus, by using a plurality of adapters, a single housing and vent system **150** may be utilized with a plurality of ventilation registers. Alternatively, the vent system **150** may be adapted to accept a core **200** with or without a member **190**.

[0028] **FIG. 1** also illustrates a control core (the core) **200** in dashed lines, and is seen to generally comprise the receiver **160**, the switch **170** and the drive **180**. The core **200** maybe adapted to enable the articulation of a ventilation register, as well as other mechanical systems. Accordingly, in one embodiment, the core **200** may be adapted to attach to an existing home register and thus provides manipulation (opening and closing) of the register without requiring the use of a register that is adapted to receive the core or other mechanics (a manipulated register). This means that one may use a register purchased “off the shelf.”

[0029] Thus, in one embodiment, the receiver 160 can be characterized as a means for wirelessly receiving a signal associated with controlling the core 200. Similarly, in one embodiment, the switch 170 can be characterized as a means for converting a received signal into a core control function, as well as a means for generating a signal for controlling the drive 180. Further, in one embodiment, the drive 180 can be characterized as a means for providing electromechanical power to a member 190.

[0030] Accordingly, to continue the above discussion, the member 190 in one embodiment couples to the drive 180 and is adapted to attach to a mechanical or electrical control portion of a ventilation register (the control portions of ventilation registers are well known in the art). Accordingly, the member 190 can be characterized as a means for coupling power from the drive 180 to a ventilation register. For example, the member 190 may be adapted to attach to the baffle of a ventilation register. Alternatively, the member 190 may be characterized as an integral portion of a ventilation register. For example, the member 190 may be a flap of a ventilation register, or may be actual baffle of a ventilation register. Thus, by integrating a core 200 into an existing ventilation register design, one can achieve remote control functionality of the ventilation register without substantially altering the appearance and without substantially changing the machining of the ventilation register.

[0031] A power supply 195 for the core 200 may provide either AC or DC power. In a preferred embodiment of the invention, the core 200 is powered via a local DC battery power supply, so that the core may be located and operated apart from any power supply system. In other words, a local power supply, in a preferred embodiment, is located entirely within the vent system 150, the housing 152 or the core 200. Preferably, the power supply 195 is a battery is storable in the housing 152.

[0032] FIG. 2 provides one embodiment of a register 400 for a heating or air-conditioning system. The register 400 is similar to a prior art register (or vent) in that it has a face 410, a grill support 420 and a plurality of flaps 422 which open and close space existing between grill slits (not visible from this view). The register 400 has been adapted for home automation use.

[0033] For example, registers have rivets that hold flaps to a grill support. In one embodiment, the register 400 may be modified by attaching the flaps 422 to the grill support 420 via rivets with no more than a pre-defined force (or tightness). In addition, the vent 400 includes a receiver 440 which is capable of receiving a remote controlled signal from a wireless remote control device (not shown) and then passes indications of remote control reception to a switch 445. The switch 445 then produces control signals capable of articulating a motor 450. The receiver 440, the switch 445, and the motor 450, are securely coupled to the grill support 420 via a support card 430.

[0034] For the present device, the motor 450 is adapted to rotate a first arm member 460 into a plurality of pre-defined rotational positions. The first arm member 460 of FIG. 4 is illustrated in what is defined as the 0° rotational position. By rotating to a 90° rotational position, the arm member 460 pulls the second arm member 462 which in turns moves a third arm member 464 to close the flaps 422 and thus seal the grill of the vent 400. Such manipulation is obvious to one of ordinary skill in mechanical control arts.

[0035] FIG. 3 provides a front view of the register shown in FIG. 2, and is a vent 400 for a heating or air-conditioning system. From FIG. 3 one can see that the front face 410 has holes 412 which allow a means for securing to secure the register 400 to a surface such as a wall or other part of a structure having a vent outlet, as is known in the art. The front face 410 also includes plurality of ribs 470, separated by slits (the space between the ribs forming slits) which together form a grill on the front face 410 of the register 400. The front face 410 also includes a wireless reception point 495, which may be used to receive radio frequency (RF) or infrared (IR) reception via an RF antenna or an IR reception transistor, as is known in the electrical communication arts.

[0036] Likewise, one embodiment of a front face 410 also includes at least one feedback Light Emitting Diode (LED) 490. The feedback LEDs 490 may be used to provide information to a user regarding whether a vent is open or closed or positioned somewhere in between an open and closed position. The feedback LEDs 490 and the wireless reception point 495 may be coupled to a computer chip, a digital signal processor, the switch 445, or the receiver 440 for example. In any event, the manipulation of such electrical components is known in the electrical control arts. In an alternative embodiment, the front face 410 also includes a solar panel 480 for providing power to the vent motor, receiver, and switch, or power storage device, such as a battery. Accordingly, the solar panel 480 may drive the vent directly or through a power storage device, and such manipulation well known in the electrical power arts.

[0037] FIGS. 4a and 4b provide an embodiment of an attachment for a vent of a heating or air-conditioning system. Referring to FIGS. 4a and 4b simultaneously, the attachment 600 includes a body 600 which is in one embodiment shaped like a four-sided pyramid with its' top-lopped off to reveal a plurality of ribs 620 (seen in FIG. 4b) which together form a grill. The attachment 600 includes a second set of ribs 622 (shown in FIG. 4a behind the ribs 620) which together form a second grill which slides next to (or behind) the first grill such that the second set of ribs 622 cover the space (slits) left between the first set of ribs 620 to stop airflow through the attachment 600.

[0038] A wireless receiver 630 receives infrared or radio frequency transmissions and passes these into a box 640 that maintains a receiver and a switch as discussed above. The receiver and switch processes signals and then control the articulation of a motor 650. The motor 650 then turns worm screw 660.

[0039] Because the box 640 is securely attached to the body 610, the worm screw holds its position relative to the box 640. An attaching member 670 is rigidly coupled to a rib 624 of the second set of ribs (each being rigidly coupled to each other), and is movably coupled to the worm screw 660 such that as the worm screw 660 turns, the member 670 travels up and down the length of the worm screw 660. Since the member 670 is rigidly attached to rib 624, the second set of ribs travel behind the first set of ribs thus allowing the register to open and close. So, when the second set of ribs is flush behind the first set of ribs air flows through the slits between the ribs 622 and between the ribs 620. Similarly, when the second set of ribs 622 is positioned over the slits between the first set of ribs 620, air does not flow through the grill and thus the vent's airflow is effectively closed. The

body 610 of the attachment 600 may also include a padded barrier 690 which compensates for mechanical irregularities in a wall-vent interface (since presumably the attachment 600 will be placed over an existing vent structure). Although not illustrated in FIG. 4a or 4b, the attachment 600 may attach to a vent or surface via magnets, or screw, or nails, or other attaching means.

[0040] The invention can be characterized as a remote controlled register. The remote control register typically includes a receiver that is capable of receiving data from a remote control device and also capable of generating an electronic signal, and an electric switch coupled to the receiver and to an electric motor. The switch is capable of passing sufficient power to drive the electric motor, and the electric motor has a drive coupled to a movable register portion, such as a damper, vent, or flap, for example, for opening and closing the register.

[0041] The receiver and the electric switch are embodied as a single component, such as an integrated circuit (IC) or a digital signal processor (DSP), a single printed circuit board having components thereon, or a customized electronic chip, for example. The choice of a combination may depend of the type of signal the receiver is to receive. In one embodiment, the remote control device and receiver communicate via an infrared signal, however, it is understood that a radio signal may also be used and may be preferred in an environment that utilizes a plurality of home automation devices. If using infrared signaling, the remote control device and receiver may be incorporated or customized using universal remote control identifiers, and in a preferred embodiment use remote control codes, such as those that are well known in the art. In alternative preferred embodiments, the receiver is uniquely identifiable with a remote control code. In another preferred embodiment, a code that uniquely identifies the register is supplied with a smart card, and thus the remote control device or the receiver are preferably adapted to receive a smart card.

[0042] When using radio waves to transmit and receive control signals, one may wish to use standard toggling controls such as those commonly found on remote control cars or airplanes, for example, or one may wish to use more sophisticated control systems, such as the IEEE 802.11 standard protocols, or Bluetooth communication protocols, for example.

[0043] Powering a vent is one problem of the prior art that is overcome with the present invention. In one embodiment, the electric motor operates using a direct current supplied by a battery, which may be rechargeable. The battery, in turn, may have its power re-supplied by a solar cell. Alternatively, a solar cell may power the motor. Likewise, it is preferred that the power source that powers the motor is also the power source that powers the receiver and switch, though this is not necessary as separate power sources may be desired for each system. Of course, other power sources are available, such as AC power sources as well as power supplied by capacitance power storage devices. Preferably, the power source is local, such as a battery, being isolated from a networked power supply.

[0044] The electric motor may be a micro motor, such as those that operate at 1.5 or 3.0 volts and generate thousands of shaft rotations per minute (RPMs). In a preferred embodiment, the electric motor is a step-motor that may be manipu-

lated into a plurality of positions, typically defined by a rotational angle (such as 45, 90, or 180 degrees, for example). In a preferred embodiment, the remote-controlled device also includes a gearbox coupled between the drive of the electronic motor and the movable member of the register (the gearbox increases the torque delivered to the movable member, the torque being produced by the electric motor).

[0045] Additional advantages may be gained from the invention by configuring the invention with a control system. In one embodiment, the control system includes a timing device coupled to the electric switch. The timing device is preferably programmable to open and/or close the vent at a predetermined time(s), and may also be programmed to open and/or close a vent when certain temperatures are reached in the proximity of the device via a thermometer. In an alternative embodiment, the control system is provided in a device that is separate from the vent. The incorporation of such devices need not be discussed in detail here since the incorporation of such devices is obvious to those of ordinary skill in the electrical control arts.

[0046] An alternative embodiment of the invention is configured to "retroactively" cover an existing vent. According the invention may be embodied as a remote controlled vent cover (vent cover). The vent cover generally includes a housing adapted to cover a substantial portion of a vent, and a receiver that is capable of receiving data from a remote control device, and is also capable of generating an electronic signal. The receiver being maintained within the housing so as to control airflow through the vent. The vent cover also includes an electric switch coupled to the receiver and to an electric motor, where the switch is capable of passing sufficient power to drive the electric motor. Preferably the electric motor has a drive that is coupled to a movable portion of the vent cover to enable the opening and closing of the vent cover, such as with a grill or grill-pair.

[0047] The invention achieves technical advantages as a remote controlled switch for opening and closing an electric circuit, such as an alternating electric current or a direct electric current. The switch includes a receiver that is capable of receiving data from a remote control device, and capable of generating an electronic signal. The electric switch is coupled to a receiver of a remote control signal, such as an infrared signal or a radio wave based signal.

[0048] The components, subsystems, systems, and methods that comprise the invention have many home automation applications. For example, the invention may be adapted to become a method of remotely opening or closing an electric switch, a method of remotely opening or closing an airflow, a method of remotely opening or closing window blinds, a method of remotely opening or closing a door, a method of remotely controlling the rotational velocity of a ceiling fan, or a method of remotely turning on or off a light bulb. Of course, after reading the above disclosure, these and many other applications of the invention will be readily apparent to those of ordinary skill in the art.

[0049] FIG. 5 illustrates one embodiment of a preferred housing 1100, which generally comprises a housing base 1102, a housing top 1104, and a battery cover 1106. The housing top 1104 includes a channel or window 1110 for receiving wireless signals. If an infrared device (such as the infrared device 1140) is chosen as the channel of sending signals to the device, then an IR receiver window 1110

(shown) is used, while if a radio frequency chosen as the channel for sending signals to the device, then an antenna may be used. Upon reading the present disclosure, the use of an antenna will be readily apparent to those of ordinary skill in the wireless arts. In addition, the window 1110 may be used for locating a thermometer or other temperature-detecting device so that a temperature may be incorporated into the invention's function. The top unit also includes a conduit 1112, as well as a spring-clip 1114, whose use and function in the invention, upon reading the present disclosure, are readily apparent to those of skill in the mechanical arts. The battery cover 1106 couples to the housing base 1102 in order to cover a local power source maintained on the housing base 1102 (presumably a battery in the preferred embodiment). The battery cover 1106 comprises a catch 1118 that couples to the spring clip 1114.

[0050] The housing base 1102 generally comprises a local power source compartment 1120. Although in the preferred embodiment the compartment 1120 maintains a battery, it should be understood that the local power source can be any functional equivalent of a battery, such as a capacitor/solar cell, or rechargeable power source, for example. Such devices should be readily apparent to those of ordinary skill in the battery arts upon reading this disclosure. The local power source compartment comprises means for delivering power from the local power source to a motor 1150, and a circuit board 1160, as is known in the electrical arts. Accordingly, the housing base 1102 is adapted to hold a motor 1150. The motor 1150 is preferably a low-torque, high-speed motor that couples to a gear box 1152, and the housing base includes a motor mount 1154 that is substantially shaped like the negative of the motor 1150 and the gearbox 1152, as will be readily understood by those of ordinary skill in the mechanical arts. The motor's motor drive (not shown) is coupled to a worm screw 1170, and a worm screw nut 1172 is coupled to the worm screw 1170 such that when the worm screw turns in a first direction the nut 1172 travels away from the motor 1150, and when the worm screw turns opposite from the first direction the nut 1172 travels towards the motor 1150 (to relate the above discussion, in this preferred embodiment, drive comprises the motor 1150, gearbox 1152, and the worm screw 1170, and the nut is an exemplary member). The housing base 1102 also maintains the circuit board 1160. Additional mechanical structure is incorporated within the housing body 1102, and may be chosen according to the needs of the specific elements employed; upon reading this disclosure, such structure is readily designable by ones of ordinary skill in the mechanical arts.

[0051] The circuit board 1160 comprises switches for delivering power to the motor 1150 as is known in the electrical arts, as well as logic 1162 to control the functions of the invention, such as receiving a signal from the wireless signal receiver 1140, powering up the motor 1150 via the switch, regulating power drainage, regulating motor speed, detecting and regulating register (i.e., nut 1172) position, and turning the wireless signal receiver, a thermometer, and a switch on and off, for example. In a preferred embodiment, the logic is a digital signal processor. The design of such electrics should be readily apparent to those in the electrical engineering and programming arts upon reading the present disclosure.

[0052] FIG. 6 is a cut view of FIG. 5 taken along cut line 6-6, showing additional detail of the housing base 1102. From this view, the motor 1150 and gear box 1152 are seen resting in the motor mount 1154. In addition, the worm screw 1170 is shown being coupled to the motor drive 1175, which has a bias wheel 1158 attached thereto. Also from this view, a channel 1190 can be seen to exist in the housing base 1102 through which the nut 1172 can travel between a first position, generally illustrated by the position of items "A", and a second position, generally illustrated by the position of items "B". Accordingly, the travel of the nut 1172 and the baffle 1192 to which it couples is between position A and position B, based on the direction of rotation of the worm screw 1170.

[0053] To assist the reader with understanding the nature of coupling the housing base 1102 to a register, FIG. 7 shows one alternative means for coupling a housing 1100 to a register 1200 via an adapter 1250. From FIG. 7, it can be seen that the housing base 1102 comprises a plurality of holes 1198 for accepting snap-on steaks 1252. The number, depth, and location of the holes is, in part, a function of the structure of the adapter 1250, which in turn has design parameters that are, in part, suggested by the register 1200. In any event, the snap-on steaks 1252 preferably couple to the holes 1198 and "snap" into the holes 1198 such that significantly more force is required to remove the housing 1000 from the adapter 1250 than is required to place the housing 1000 onto the adapter 1250. Accordingly, the specific size and shape of the holes 1198 and the snap-on steaks 1252, as well as the snap-on feature itself, will be readily apparent to those of ordinary skill in the mechanical arts upon reading the present disclosure. In addition, it is understood that the snap-on steaks are exemplary, and other means of coupling the adapter 1250 to the housing 100 will be apparent to those of ordinary skill in the mechanical arts.

[0054] Also from FIG. 7 it is seen that the adapter 1250 includes means for coupling the adapter to the register 1200. The adapter 1250 generally includes a base plate 1262, a side brace 1256, an end brace 1264 having spring-fingers 1254 coupled thereto, and a grill plate 1258 having elongated spring fingers 1260. Of course, the illustrated elements of the adapter 1250 are exemplary, and one of ordinary skill in the mechanical arts will readily recognize, upon reading this disclosure, that other alternative means are available for coupling the adapter 1250 to a register, and such functional equivalents, like all functional equivalents identified in this application, are incorporated herein.

[0055] Accordingly, in the preferred embodiment, a user first couples the adapter 1250 to the register 1200 by aligning the end brace 1264 with the appropriate end of the register 1200 such that the knobs 1266 of the spring fingers 1254 grasp the end edge 1206 of the register 1200. Next, the user "rocks" the adapter plate 1250, using the edge 1206 as the fulcrum, such that the side brace 1256 abuts the side edge 1204 of the register 1250. Then, as the adapter plate 1250 is rocked to rest on the register, the grill plate 1258 naturally assumes a position upon a register rib 1202, and the elongated spring fingers 1260 couple to the register rib 1202, preferably allowing a bend 1268 in the elongated spring fingers 1260 to grab an edge 1208 of the register rib 1202. At this point, the housing 1000 is coupled to the adapter 1200, taking care to align the nut 1172 with the baffle 1192.

[0056] Thus, though the invention has been described with respect to a specific preferred embodiment, many variations and modifications will become apparent to those skilled in the art upon reading the present application. It is therefore the intention that the appended claims be interpreted as broadly as possible in view of the prior art to include all such variations and modifications.

What is claimed is:

1. A remote controlled ventilation register attachment, comprising:

a housing that is adapted to attach to an adapter and also adapted to maintain at least a receiver, a switch, a drive, and a power source;

the adapter being configured to couple the housing to a ventilation register;

the receiver located in the housing and capable of receiving a signal directly from a remote control device, and also capable of generating an electric signal for the switch;

the switch coupled to the receiver and to the drive;

the switch having logic capable of controlling a supply of power to the drive; and

the drive being adapted to couple to a member.

2. The remote controlled ventilation register attachment of claim 1 wherein the power source is a battery.

3. The remote controlled ventilation register attachment of claim 1 wherein the adapter comprises a snap hook that couples to the ventilation register, and a snap that couples to the housing.

4. The remote controlled ventilation register attachment of claim 1 wherein the adapter is configured to couple to a plurality of ventilation registers.

5. The remote controlled ventilation register attachment of claim 1 wherein the adapter couples to a front portion of the ventilation register.

7. The remote controlled ventilation register attachment of claim 1 wherein the adapter couples to a rear portion of the ventilation register.

8. The remote controlled ventilation register attachment of claim 1 wherein the adapter is a metal plate comprising a ventilation register clamp and a housing mount.

9. The remote controlled ventilation register attachment of claim 1 wherein the adapter comprises a strap that is adapted to couple to the housing.

10. The remote controlled ventilation register attachment of claim 1 wherein the adapter comprises a strap that is adapted to couple to the ventilation register.

11. The remote controlled ventilation register attachment of claim 1 wherein the adapter comprises magnets adapted to couple to the ventilation register.

12. The remote controlled ventilation register attachment of claim 1 wherein the housing mount is a snap-on steak.

13. The remote controlled ventilation register attachment of claim 1 wherein the housing is integrated within the body of a ventilation register.

14. A method of remotely opening or closing a ventilation register, comprising:

a housing comprising a receiver, a logic, a local power source, and a motor;

receiving a wireless signal at the receiver;

using the logic to convert the signal into a motor signal; and

running the motor to articulate a ventilation register;

wherein the motor, the receiver, and the logic are powered with the local power source.

15. The method of claim 14 wherein the housing is adapted to couple to the ventilation register.

16. The method of claim 14 wherein the housing is integrally formed with the ventilation register.

17. A method of remotely opening or closing a ventilation register via a housing that removably couples about a portion of an exposed face of a ventilation register, comprising:

receiving a wireless signal;

using logic to convert the signal into a motor signal; and

utilizing a local power source to run a motor to articulate a ventilation register between an open and a closed position.

* * * * *