



INTERNATIONAL APPLICATION PUBLISHED UNDER THE PATENT COOPERATION TREATY (PCT)

<p>(51) International Patent Classification ⁵ : G11B 5/012, 17/03</p>	<p>A1</p>	<p>(11) International Publication Number: WO 94/09486 (43) International Publication Date: 28 April 1994 (28.04.94)</p>
<p>(21) International Application Number: PCT/US93/09283 (22) International Filing Date: 29 September 1993 (29.09.93) (30) Priority data: 958,858 8 October 1992 (08.10.92) US (71) Applicant: INTEGRAL PERIPHERALS, INC. [US/US]; 5775 Flatiron Parkway, Suite 100, Boulder, CO 80301 (US). (72) Inventor: FURAY, David, M. ; 1420 Bluebell, Boulder, CO 80302 (US). (74) Agents: STEUBER, David, E. et al.; Skjerven, Morrill, MacPherson, Franklin & Friel, 25 Metro Drive, Suite 700, San Jose, CA 95110 (US).</p>		<p>(81) Designated States: JP, European patent (AT, BE, CH, DE, DK, ES, FR, GB, GR, IE, IT, LU, MC, NL, PT, SE). Published <i>With international search report.</i> <i>With amended claims.</i></p>

(54) Title: MOUNTING ARRANGEMENT FOR DISK DRIVE

(57) Abstract

A disk drive (10) including a pair of side rails (101, 102) and a connector (105) is disclosed. The disk drive (10) may advantageously be connected to a personal computer, in a location normally reserved for a memory card. The disk drive (10) may be constructed to conform to specification issued by the Personal Computer Memory Card International Association (PCMCIA).

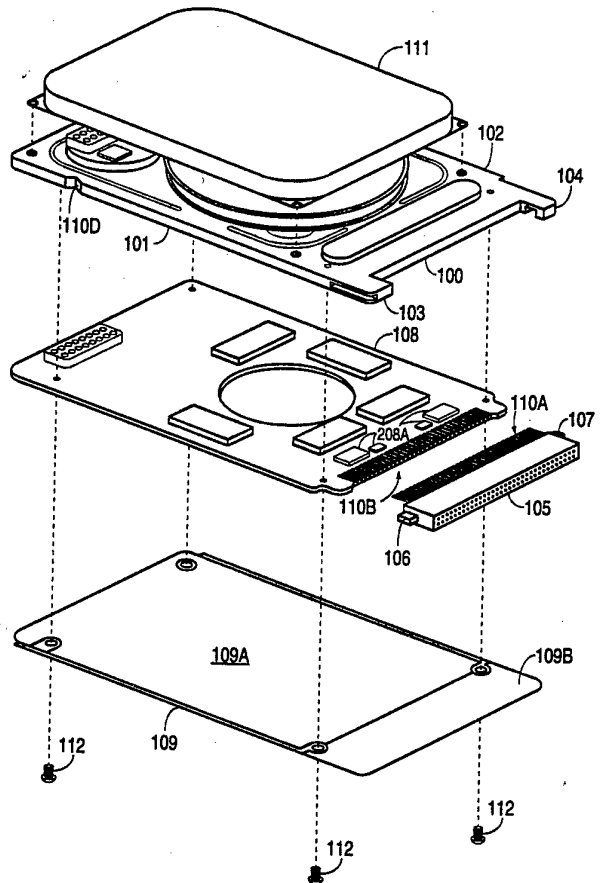

FOR THE PURPOSES OF INFORMATION ONLY

Codes used to identify States party to the PCT on the front pages of pamphlets publishing international applications under the PCT.

AT	Austria	FR	France	MR	Mauritania
AU	Australia	GA	Gabon	MW	Malawi
BB	Barbados	GB	United Kingdom	NE	Niger
BE	Belgium	GN	Guinea	NL	Netherlands
BF	Burkina Faso	GR	Greece	NO	Norway
BG	Bulgaria	HU	Hungary	NZ	New Zealand
BJ	Benin	IE	Ireland	PL	Poland
BR	Brazil	IT	Italy	PT	Portugal
BY	Belarus	JP	Japan	RO	Romania
CA	Canada	KP	Democratic People's Republic of Korea	RU	Russian Federation
CF	Central African Republic	KR	Republic of Korea	SD	Sudan
CG	Congo	KZ	Kazakhstan	SE	Sweden
CH	Switzerland	LI	Liechtenstein	SI	Slovenia
CI	Côte d'Ivoire	LK	Sri Lanka	SK	Slovak Republic
CM	Cameroon	LU	Luxembourg	SN	Senegal
CN	China	LV	Latvia	TD	Chad
CS	Czechoslovakia	MC	Monaco	TG	Togo
CZ	Czech Republic	MG	Madagascar	UA	Ukraine
DE	Germany	ML	Mali	US	United States of America
DK	Denmark	MN	Mongolia	UZ	Uzbekistan
ES	Spain			VN	Viet Nam
FI	Finland				

- 1 -

MOUNTING ARRANGEMENT FOR DISK DRIVE

FIELD OF THE INVENTION

This invention relates to a disk drive useable in
5 place of a printed circuit memory card in a personal
computer and, in particular, to a disk drive meeting the
specifications established by the Personal Computer Memory
Card International Association.

BACKGROUND OF THE INVENTION

10 Integrated circuit memory cards have become popular
as a means of conveniently adding memory capacity to
personal computers, particularly palm top, lap top, and
notebook-sized computers, as well as other devices such as
modems, serial ports, cellular phone links, facsimile
15 machines, application read-only memories, etc. To promote
compatibility among memory cards, physical, interface and
software standards have been adopted by the Personal
Computer Memory Card International Association (PCMCIA) in
the United States and by the Japan Electronics Industry
20 Development Association (JEIDA). The current PCMCIA Card
Standard (Release 2.0, September 1991), which is
incorporated herein by reference, provides for two
physical sizes, designated Type I and Type II, which are
distinguished from each other primarily by specifying card
25 thicknesses of 3.3 mm and 5.0 mm, respectively. The
memory cards are provided with a 68-pin socket connector
at one end and are typically guided into place by a pair
of channel guides which engage the side edges of the card.

Integrated circuit memory cards permit up to about 20
30 megabytes of storage to be added to the host computer.
Recently, it has been proposed that the PCMCIA adopt
several additional size standards, designated Type III and
Type IV, specifying card thicknesses of 10.5 mm and a
greater thickness in the range 12.5-18.0 mm. These larger
35 sizes raise the possibility of substituting a small disk

- 2 -

drive, having disks 1.8 inches in diameter, for example, in place of the solid state memory. This would permit a substantially larger memory capacity, e.g., 100 megabytes, to be added to the host computer.

5 At present, disk drives are generally mounted in small computers by means of screw fasteners and are connected electrically by means of a cable and a connector. Alternatively, the drive may have a built-in connector and may be mounted onto the computer directly
10 with some type of retaining means. A disk drive compatible with PCMCIA specifications could more easily be mounted in a computer, without special technical training or extra hardware, either as a part of the manufacturing process or as a field replacement or upgrade. Such a
15 drive could also be used as a removable storage device.

SUMMARY OF THE INVENTION

A disk drive in accordance with this invention comprises a pair of side rails and a connector, both the side rails and the connector being firmly mounted to the
20 disk drive. In a preferred embodiment, both the side rails and the connector meet the standards issued or proposed for adoption by the PCMCIA for memory cards. In particular, the connector is a socket connector having a two row, 1.27 mm grid, capable of receiving 68 pins. The
25 side rails each have a height of 3.3 mm, and the outside edges of the side rails are spaced 54 mm apart. Thus, the side rails are properly dimensioned and spaced so as to fit into the channel guides for a standard PCMCIA memory card.

30 In the preferred embodiment the side rails are integrally formed as part of a base housing on which the spin motor assembly, actuator and other components of the drive are mounted. In an alternative embodiment, the side rails are separate elements which are attached to the
35 edges of a printed circuit board (PCB) on which the integrated circuits are mounted.

- 3 -

DESCRIPTION OF THE DRAWINGS

Figure 1A illustrates an exploded view of a preferred embodiment in accordance with the invention.

Figure 1B illustrates an exploded view of the same 5 embodiment, with the disk drive inverted.

Figure 1C illustrates a detailed view of a corner of the same embodiment.

Figure 2A illustrates a plan view of the preferred embodiment.

10 Figure 2B illustrates a cross-sectional view taken at section A-A in Figure 2A.

Figure 2C illustrates a front elevational view taken from the connector end of the disk drive illustrated in Figure 2A.

15 Figure 3A illustrates a plan view of the base housing, with the cover, spin motor assembly, actuator and disks removed.

Figure 3B illustrates a front elevational view of the structure illustrated in Figure 3A.

20 Figure 3C illustrates a cross-sectional view of the structure illustrated in Figure 3A, taken at section B-B.

Figure 4 illustrates an exploded view of a second embodiment according to the invention.

25 Figures 5A, 5B and 5C illustrate plan and side and front elevational views, respectively, of the embodiment illustrated in Figure 4.

Figures 6A and 6B illustrate plan and side views, respectively, of one of the side rails illustrated in Figure 4.

30 DESCRIPTION OF THE INVENTION

Two embodiments in accordance with this invention will be described. The preferred embodiment, illustrated in Figures 1-3, includes a base housing with which the side rails are integrated and to which the connector is 35 firmly attached. The second embodiment, illustrated in Figures 4-6, includes separate side rails which are

- 4 -

attached to the respective side edges of the disk drive printed circuit board (PCB).

Figure 1A illustrates an exploded view of a disk drive 10. A base housing 100, which is preferably formed of aluminum, although plastic or steel may also be used, includes side rails 101 and 102. Side rails 101 and 102 terminate in connector mounting structures 103 and 104, respectively. A connector 105, which is a 68-pin PCMCIA-compatible socket connector, has tabs 106 and 107 which mate with slots formed in structures 103 and 104. Tabs 106 and 107 are fitted into the corresponding slots in structures 103 and 104 to provide a firm connection between connector 105 and base housing 100. This results in an extremely rugged, durable arrangement which will maintain its integrity after repeated insertion into a computer. Connector 105 is advantageously a multiple insertion connector such as Elco Corporation Part No. CH96 1800 0011 00 0005.

Sandwiched to base housing 100 are a printed circuit board (PCB) 108 and a shield member 109, which includes an insulating layer 109A bonded to an ESD shield 109B. A set of contacts 110A on connector 105 are electrically bonded to opposing contacts 110B on PCB 108. A die cast aluminum cover 111 fits over the disks, actuator and other elements which are mounted on base housing 100 and is mounted to base housing 100 by means of four screws (not shown). The sandwich assembly of base housing 100, PCB 108 and shield member 109 is held together by a set of screws 112 which are threaded into base housing 100. The insertion of tabs 106 and 107 into the slots in structures 103 and 104 forms a rigid structural unit and removes stress from PCB 108 when disk drive 10 is inserted into a computer or other device.

Base housing 100 includes a V-shaped notch 100D which mates with a suitable means (e.g., a spring-loaded ball or tab) to retain the disk drive firmly in position after it has been mounted in a computer or other instrument. Other

- 5 -

suitable retention means (e.g., an external spring finger) may also be used, and a retention means may be provided on each side of disk drive 10.

Figure 1B is a view of the same embodiment which has been inverted. It will be noted that base housing 100 includes a cavity 100A which provides room for chips or other components mounted on the side of PCB 108 which faces base housing 100. Base housing 100 also includes a peripheral lip 100B (more clearly visible in Figure 1C) which provides support for the edges of shield member 109.

This structure is shown in greater detail in Figure 1C, which shows PCB 108 positioned against base housing 100. An edge 109A of shield member 109 mates with lip 100B so that a main portion 109D of shield member 109 is spaced somewhat from PCB 108. Main portion 109D is also raised from edge 109A to provide greater clearance from printed circuit board 108. (This structure is clearly visible in Figure 2B.) A concave portion 109B is formed around screw hole 109C, the depth of concave portion 109B being adjusted such that the edge of hole 109C touches PCB 108. In this way base housing 100 and shield member 109 form a completely shielded cavity for PCB 108 and any components mounted thereon. No separate housing or "box" to shield these components is required. This assumes, of course, that base housing 100 is made of a metal. The firm pressure between edge 109A and lip 100B provides a dust tight seal which protects PCB 108 and the other components mounted in the cavity. The overlap between edge 109A and lip 100B improves the shielding capability of the structure (see Noise Reduction Techniques in Electronic Systems, Henry W. Ott, John Wiley & Sons (1988), Figure 6-26).

Figures 2A, 2B and 2C illustrate in greater detail the positioning of the various components inside disk drive 10. Figure 2A is a detailed top view of disk drive 10 with cover 11 removed. Figure 2B is a cross-sectional view taken at section A-A (shown in Figure 2A), with cover

- 6 -

111 in place.

As shown in Figure 2B, a spin motor assembly 200 is mounted into an aperture in base housing 100. Spin motor assembly 200 includes a spindle 201 which protrudes 5 through the aperture and to which a pair of data storage disks 202 are affixed. Spin motor assembly 200 is adhesively bonded to a lip 300A of an aperture 300 in base housing 100 (see Fig. 3A). PCB 108 lies directly beneath base housing 100 and has attached to it components 10 represented by 203A, 203B and 203C. Thus, printed circuit board 108 and its components, including components 203A-203C, are set in a cavity which is shielded by shield 109 on the bottom and base housing 100 on the top.

An actuator bearing cartridge 204 is mounted on top 15 of base housing 100 by inserting a post on the end thereof into a hole 204A in base housing 100. Alternatively, actuator bearing cartridge 204 may be attached to base housing 100 by screw fasteners or bonding. An actuator 205 is fastened to a post on actuator bearing cartridge by 20 means of a screw 205A. Actuator 205 contains heads 206 to read and write data to disks 202. A connector 207 projects through an aperture in base housing 100 and permits electrical signals to be transmitted between PCB 108 and the components mounted on top of base housing 100. 25 While a dynamic loading drive is illustrated in Figures 1-3, the principles of this invention also apply to contact start stop (CSS) drives.

As shown in Figure 2B, base housing 100 also includes an enclosure 208 which provides a shield for connectors 30 110A and 110B and also encloses four IC chips 208A shown in Figure 1A.

Disk drive 10 is designed to meet the PCMCIA Type III specification, which is currently proposed. This requires that disk drive 10 have a length of 86.6 mm and a width of 35 54.0 mm. These dimensions are indicated on Figure 2A. In addition, the Type III specification requires that side rails 101 and 102 have a thickness of 3.3 mm and that the

- 7 -

total height of disk drive 10 not exceed 10.5 mm. These dimensions are shown in Figure 2C. In addition, Figure 2C illustrates polarization features which are included in structures 103 and 104 in accordance with PCMCIA specifications, including a slot 103A in structure 103 and a recess on the upper edge of structure 104. In accordance with PCMCIA specifications, these features extend a distance of 10.0 mm back from the front edge of connector 105.

10 Figure 3 illustrates several features of base housing 100 which are not apparent from Figures 1 and 2. Figure 3 shows an aperture 300 which is formed in base housing 100 and a lip 300A to which spin motor assembly 200 is bonded. Also a structure 301 for mounting actuator bearing 204 is 15 indicated, as is an aperture 302 for connector 207. The edges of cover 111 fit around a wall 304 which extends partially around the perimeter of disk drive 10. Figure 3C illustrates a cross-sectional view of base housing 100 taken at section B-B shown in Figure 3A.

20 It will be appreciated that the principles of this invention are not limited to the Type III PCMCIA specification. For example, disk drive 10 could be constructed in accordance with the PCMCIA Type IV or Type V proposed specifications, which are similar to the 25 Type III specification but allow an overall height of 12.5 mm or 15.0 mm, respectively. Disk drive 10 may also be constructed without regard to any PCMCIA specification.

Figure 4 illustrates an exploded view of an alternative embodiment in accordance with the invention. 30 Included in a disk drive 40 is a PCB 400, on which are mounted several integrated circuit chips and other electronic components. A pair of side rails 401 and 402 are attached to the edges of PCB 400. As shown in Figures 6A and 6B, side rail 401 has a groove 60 on its inside 35 face into which an edge of PCB 400 is fitted. The edge of PCB 400 is bonded into groove 60 with a suitable adhesive (for example, LOCTITE brand adhesive). Side rail 402 is

- 8 -

bonded in a similar manner to the opposite edge of PCB 400.

Referring again to Figure 4, a connector 403, which advantageously conforms to PCMCIA specifications, has tabs 5 404 and 405 which fit into corresponding recesses in side rails 401 and 402. Tabs 404 and 405 are securely fitted into side rails 401 and 402 to provide the maximum possible rigidity to the structure. Leads 406A on connector 403 are electrically connected to contacts 406B 10 on PCB 400. A shielding plate 411 provides electrostatic and electromagnetic shielding for leads 406A and contacts 406B. A head disk assembly 407 which includes a spin motor assembly, disk and activator, is attached to PCB 400 by means of four screws (not shown) which fit through 15 holes 407A, two of which extend also through tabs 411A of shield 411. A shield 408 is attached to the underside of PCB 400 by screws 409. A cover 407B of head disk assembly 407 and shield 409 provide electrostatic and electromagnetic shielding for the components on PCB 400. 20 A circular aperture 410 in shield 408 provides room for a lower surface of the spin motor assembly (not shown) in head disk assembly 407. Aperture 410 may be omitted in some embodiments.

A plan view and side and front elevational views of 25 disk drive 40 are illustrated in Figures 5A, 5B and 5C. From Figure 5C it is apparent that side rails 401 and 402 contain polarization features similar to those illustrated in Figure 2C. In addition, the height of side rails 401 and 402, and the other dimensions of disk drive 40, comply 30 with the PCMCIA Type III specification.

The embodiments described above are intended to be illustrative and not limiting. Many additional and alternative embodiments will be apparent to those skilled in the art, all of which are included within the broad 35 principles of this invention, as defined in the following claims.

CLAIMS

I claim:

1. A disk drive comprising:
 - 5 a base housing member comprising a pair of side rails, said side rails being oriented parallel to each other;
 - a spin motor assembly and an actuator mounted on said base housing member; and
 - 10 an electrical connector fixed to said base housing member;wherein each of said side rails defines an edge of said disk drive and wherein said side rails are for mounting said disk drive in a pair of channel guides in a computer or other instrument.
- 15 2. The disk drive of Claim 1 wherein said electrical connector is fixed to respective ends of said side rails.
3. The disk drive of Claim 2 wherein said electrical connector is a socket connector.
- 20 4. The disk drive of Claim 3 comprising a printed circuit board attached to said base housing member.
5. The disk drive of Claim 1 wherein said side rails are approximately 3.3 mm thick and said edges are approximately 54 mm apart.
- 25 6. The disk drive of Claim 1 comprising means for retaining said disk drive in position when mounted in a computer or other instrument.
7. The disk drive of Claim 1 wherein at least one of said side rails includes a polarization feature to
30 ensure that said disk drive is oriented correctly when mounted.

- 10 -

8. A disk drive comprising:
a head disk assembly, said head disk assembly including a spin motor, an actuator and a disk;
a printed circuit board having a pair of side edges;
5 a pair of side rails attached to said side edges, respectively, of said printed circuit board;
and
an electrical connector fixed to respective ends
10 of said side rails.
wherein each of said side rails defines an edge of said disk drive and wherein said side rails are for mounting said disk drive in a pair of channel guides in a computer or other instrument.
- 15 9. The disk drive of Claim 5 wherein each of said side rails comprises a groove, an edge of said printed circuit board being fitted in said groove.
- 10 10. The disk drive of Claim 5 wherein said electrical connector is fixed to each of said side rails
20 by means of a tab on said connector inserted into a recess in said side rail.
11. The disk drive of Claim 5 wherein said electrical connector is a socket connector.
- 25 12. The disk drive of Claim 8 wherein said side rails are approximately 3.3 mm thick and said edges are approximately 54 mm apart.
13. The disk drive of Claim 8 comprising means for retaining said disk drive in position when mounted in a computer or other instrument.
- 30 14. The disk drive of Claim 8 wherein at least one of said side rails includes a polarization feature to

- 11 -

ensure that said disk drive is oriented correctly when mounted.

15. A disk drive comprising:
a base housing member, an actuator being mounted
5 on said base housing member;
electronic components for controlling said disk
drive; and
a shield member, wherein said base housing and
said shield member are configured so as to form a
10 shielded cavity in which said electronic components
are mounted.

16. The disk drive of Claim 15 wherein said
electronic components are mounted on a printed circuit
board, said printed circuit board and said components
15 being positioned inside said cavity.

AMENDED CLAIMS

[received by the International Bureau on 18 January 1994 (18.01.94); original claims 1,2,6,8-11 and 15 amended; other claims unchanged (4 pages)]

1. A disk drive comprising:
 - a pair of side rails, said side rails being
 - 5 oriented parallel to each other and extending laterally outward from opposite sides of said disk drive;
 - a spin motor assembly and an actuator mounted on a base housing member; and
 - 10 an electrical connector fixed to an end of said disk drive, said electrical connector being oriented so as to mate with a corresponding electrical connector when said disk drive is moved in a direction parallel to said side rails;
 - 15 wherein said pair of side rails are configured for sliding into a pair of channel guides included in a memory card slot in a computer or other instrument.
2. The disk drive of Claim 1 wherein each of said side rails has a thickness substantially less than a
- 20 thickness of said disk drive generally.
3. The disk drive of Claim 2 wherein said electrical connector is a socket connector.
4. The disk drive of Claim 3 comprising a printed circuit board attached to said base housing member.
- 25 5. The disk drive of Claim 1 wherein said side rails are approximately 3.3 mm thick and said edges are approximately 54 mm apart.
6. The disk drive of Claim 1 comprising means for retaining said disk drive in position when said side rails
- 30 are disposed within said channel guides.
7. The disk drive of Claim 1 wherein at least one

of said side rails includes a polarization feature to ensure that said disk drive is oriented correctly when mounted.

8. A disk drive comprising:

- 5 a head disk assembly, said head disk assembly including a spin motor, an actuator and a disk;
a printed circuit board having a pair of side edges;
a pair of side rails attached to said side
10 edges, respectively, of said printed circuit board, said side rails being parallel to each other; and
an electrical connector fixed to respective ends of said side rails, said electrical connector being oriented so as to mate with a corresponding
15 electrical connector when said disk drive is moved in a direction parallel to said side rails;
wherein each of said side rails defines an edge of said disk drive and wherein said side rails are configured for sliding into a pair of channel guides
20 included in a memory card slot in a computer or other instrument, said side rails being parallel to each other.

9. The disk drive of Claim 8 wherein each of said side rails comprises a groove, an edge of said printed
25 circuit board being fitted in said groove.

10. The disk drive of Claim 8 wherein said electrical connector is fixed to each of said side rails by means of a tab on said connector inserted into a recess in said side rail.

30 11. The disk drive of Claim 8 wherein said electrical connector is a socket connector.

12. The disk drive of Claim 8 wherein said side

rails are approximately 3.3 mm thick and said edges are approximately 54 mm apart.

13. The disk drive of Claim 8 comprising means for retaining said disk drive in position when mounted in a 5 computer or other instrument.

14. The disk drive of Claim 8 wherein at least one of said side rails includes a polarization feature to ensure that said disk drive is oriented correctly when mounted.

10 15. The disk drive of Claim 1 further comprising:
electronic components for controlling said disk
drive; and
a shield member positioned adjacent said base
housing member, wherein said base housing member and
15 said shield member are configured so as to form a
shielded cavity in which said electronic components
are mounted.

16. The disk drive of Claim 15 wherein said
electronic components are mounted on a printed circuit
20 board, said printed circuit board and said components
being positioned inside said cavity.

17. The disk drive of Claim 15 wherein said base
housing member and said shield member are capable of
providing electrostatic and electromagnetic shielding for
25 said spin motor assembly, said actuator and said
electronic components.

18. The disk drive of Claim 1 wherein each of said
side rails is rectangular in cross section.

19. The disk drive of Claim 8 further comprising:
30 a shield member positioned adjacent an underside

of said printed circuit board; and

a cover member, said cover member and said shield member forming a cavity in which said printed circuit board is mounted.

5 20. The disk drive of Claim 19 wherein said shield member and said cover member are capable of providing electrostatic and electromagnetic shielding for said head disk assembly.

21. In a computer or other instrument, a combination
10 comprising:

a pair of channel guides mounted in said computer or other instrument and configured so as to engage the side edges of a memory card;

15 an electrical connector mounted in said computer or other instrument and adapted so as to mate with an electrical connector of a memory card;

a disk drive comprising a pair of side rails and an electrical connector positioned at an end of said disk drive;

20 wherein each of said side rails is movably disposed in one of said channel guides and the electrical connector mounted in said computer or other instrument is in electrical contact with the electrical connector of said disk drive.

25 22. The combination of Claim 21 wherein said disk drive comprises a means of retaining said side rails in position in said channel guides.

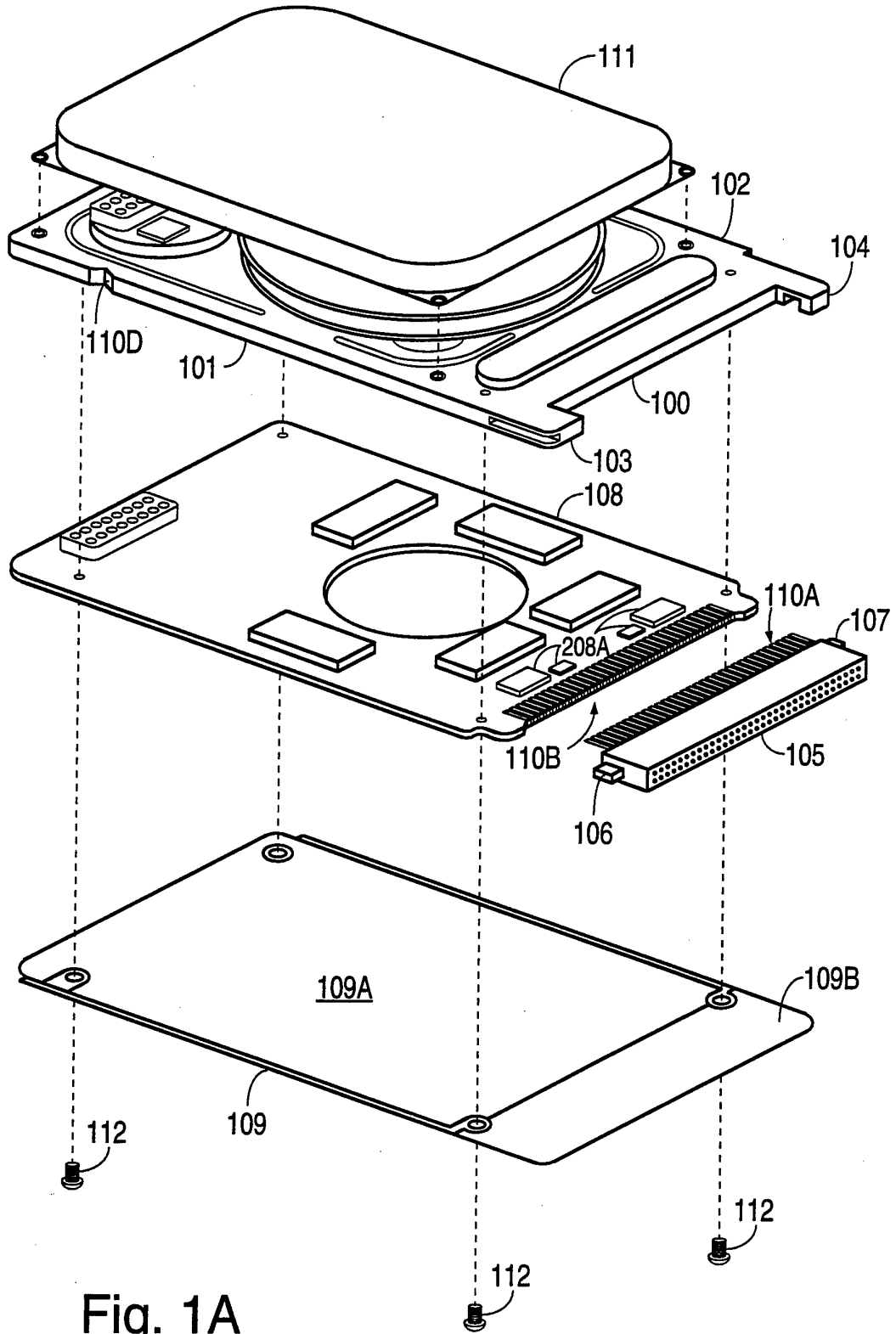

Fig. 1A

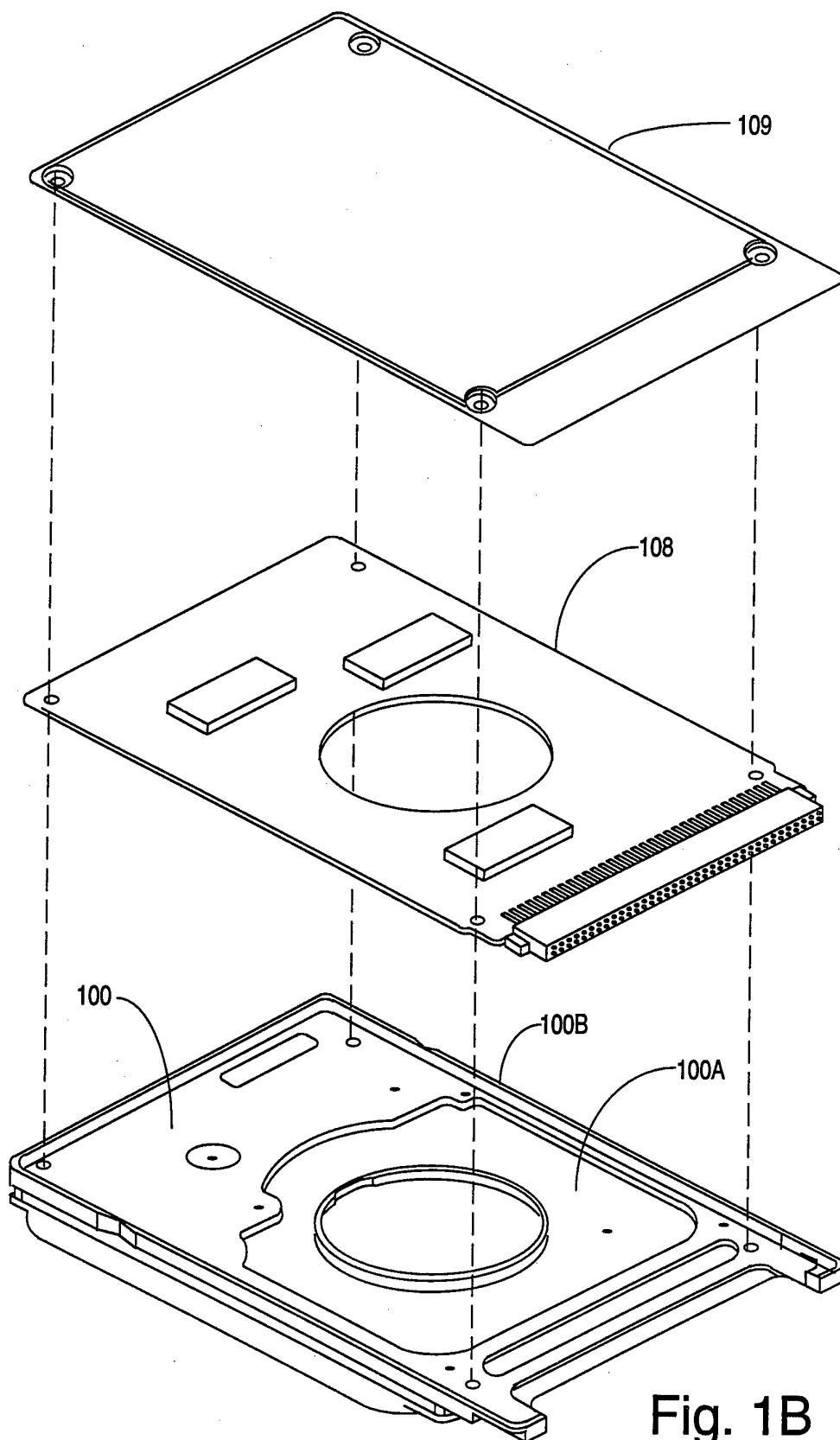

Fig. 1B

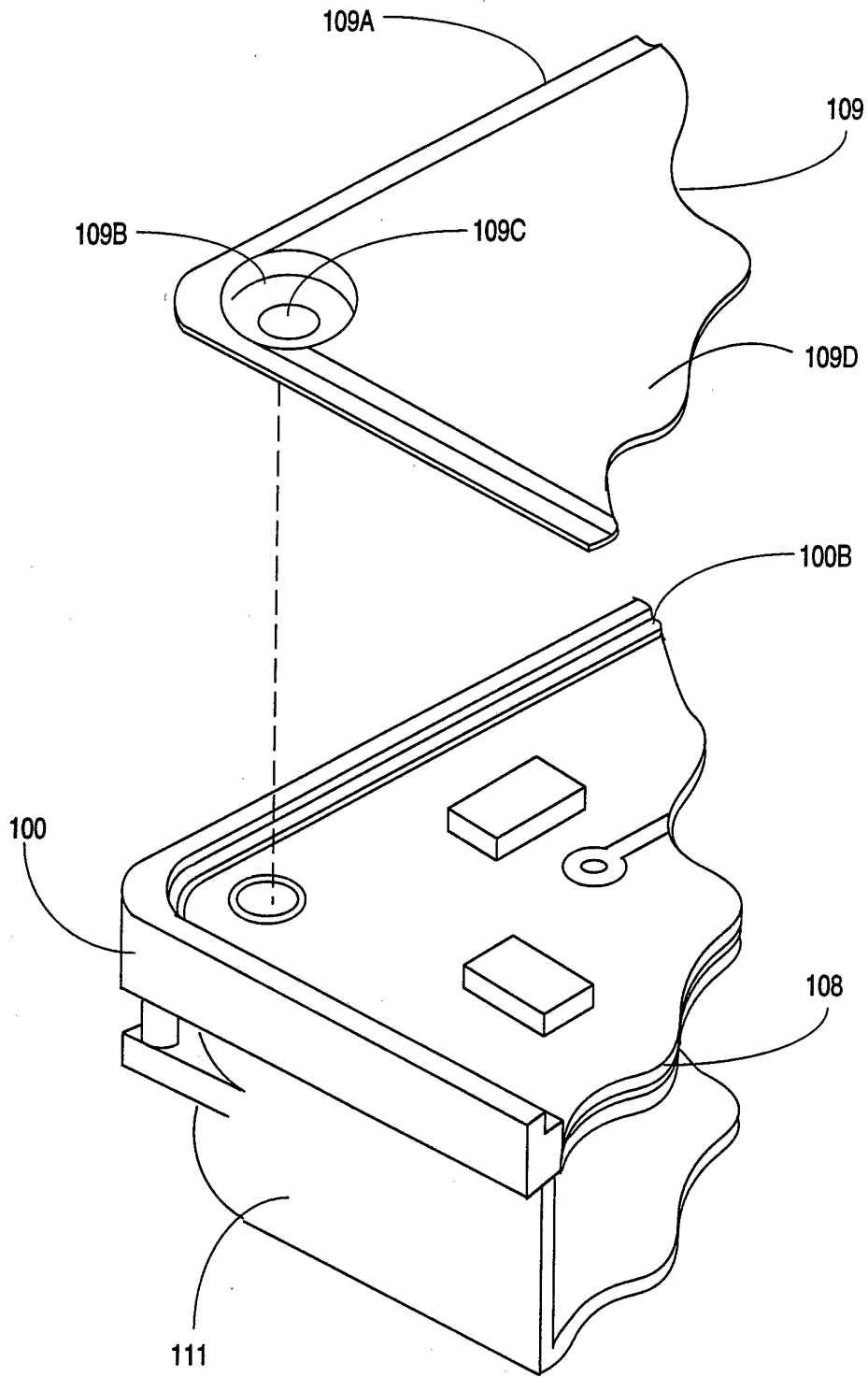

Fig. 1C

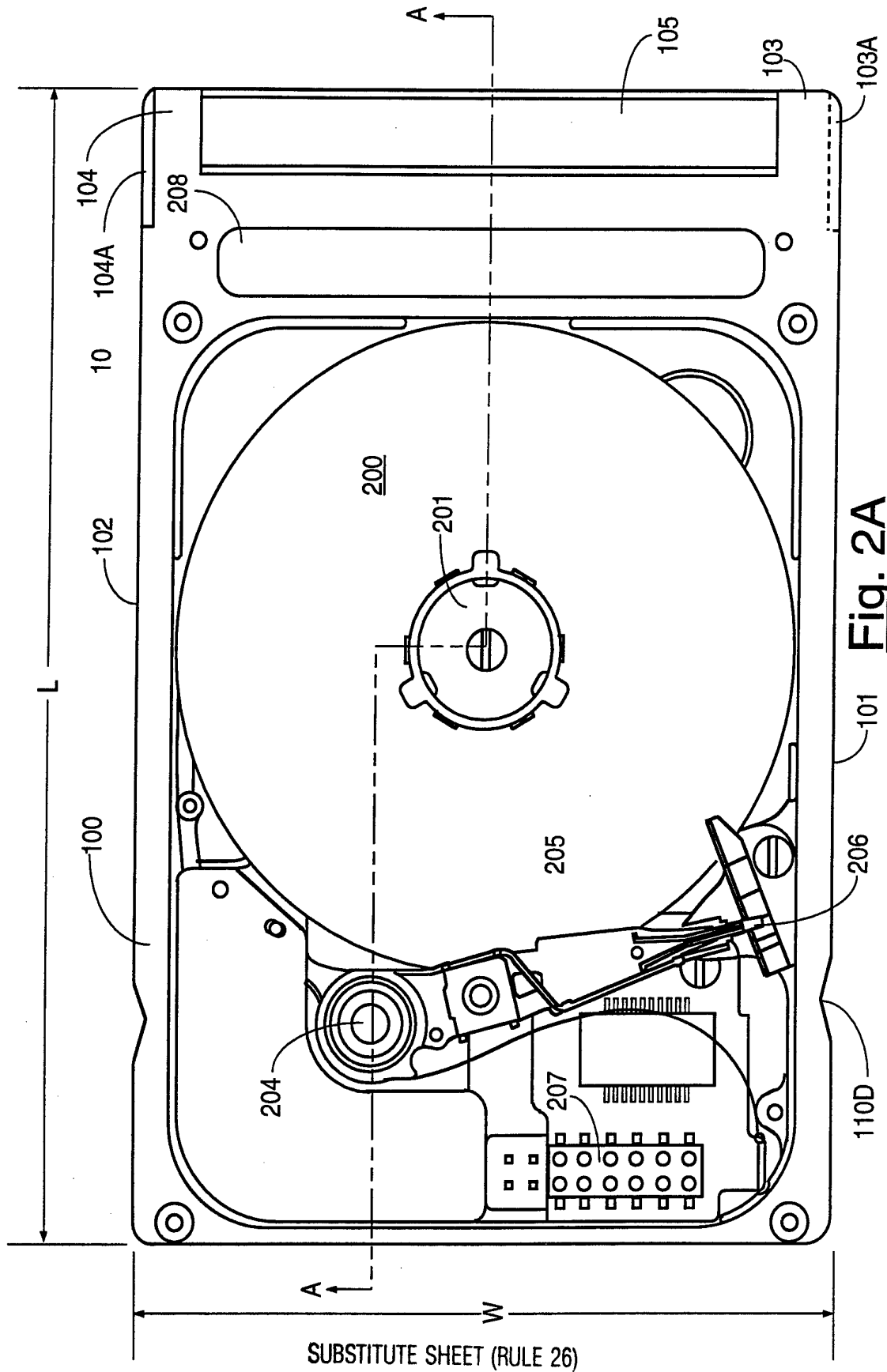

Fig. 2A

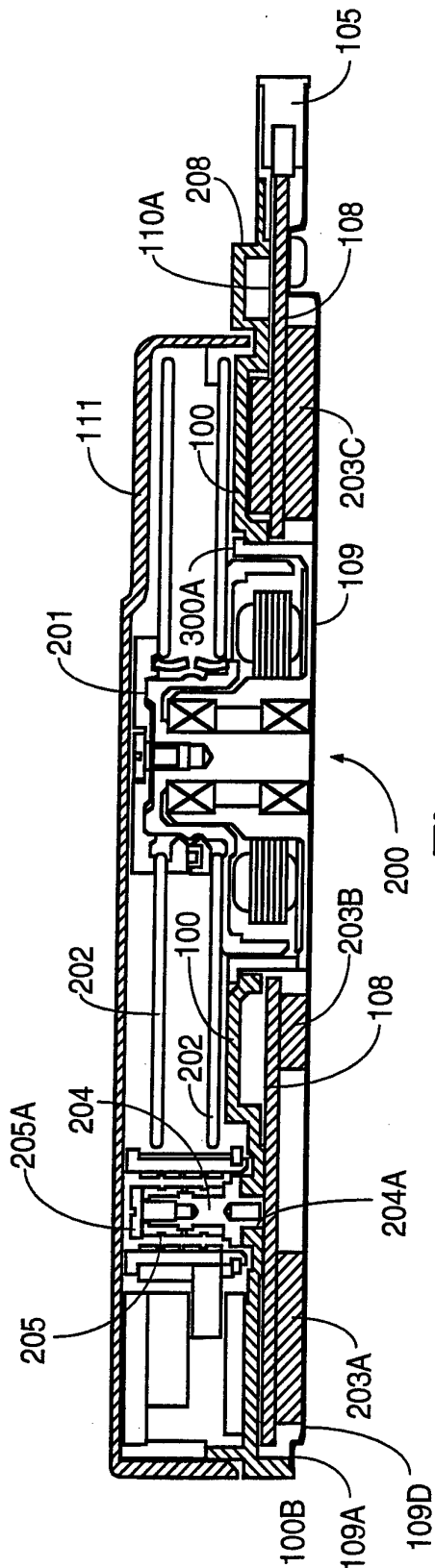

Fig. 2B

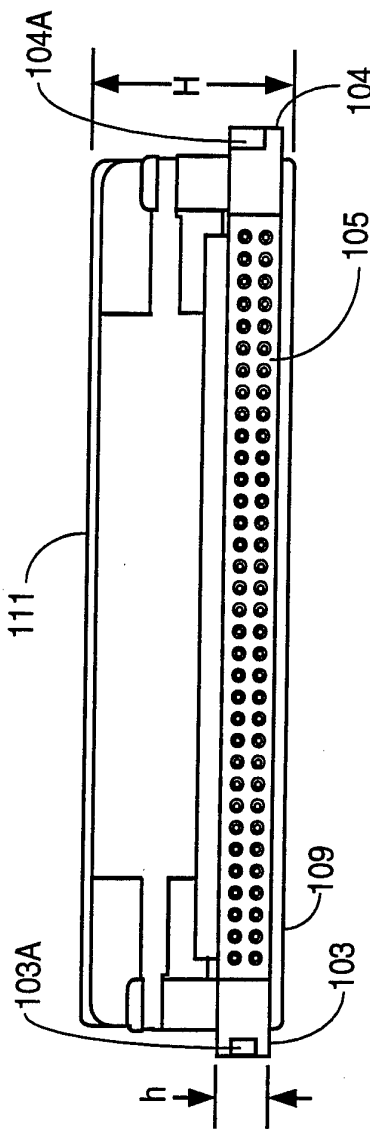

Fig. 2C

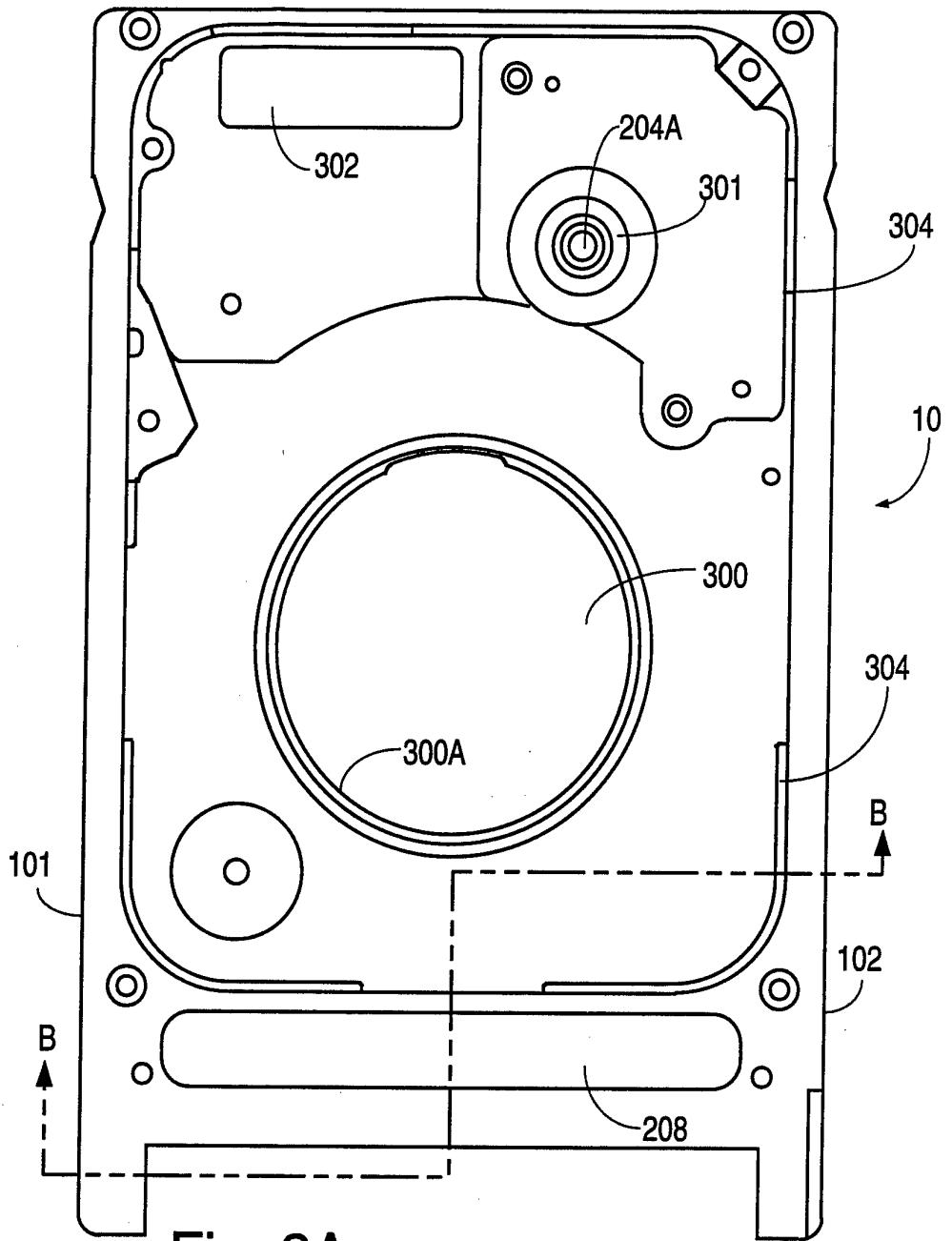

Fig. 3A

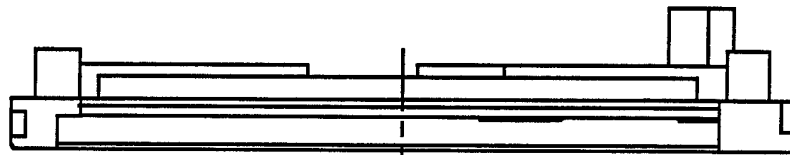

Fig. 3B

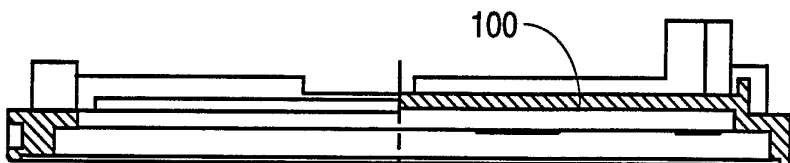

Fig. 3C

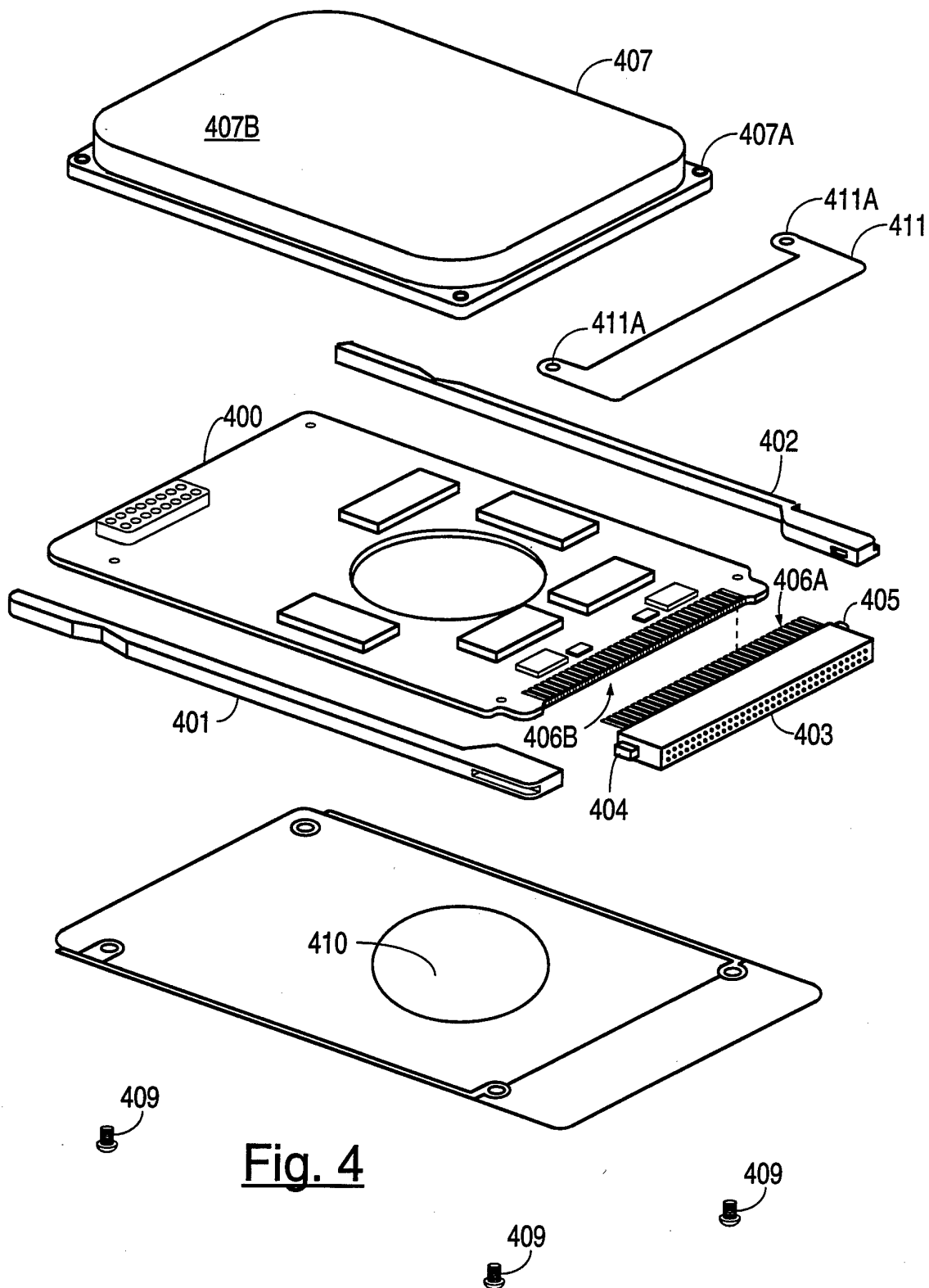

Fig. 4

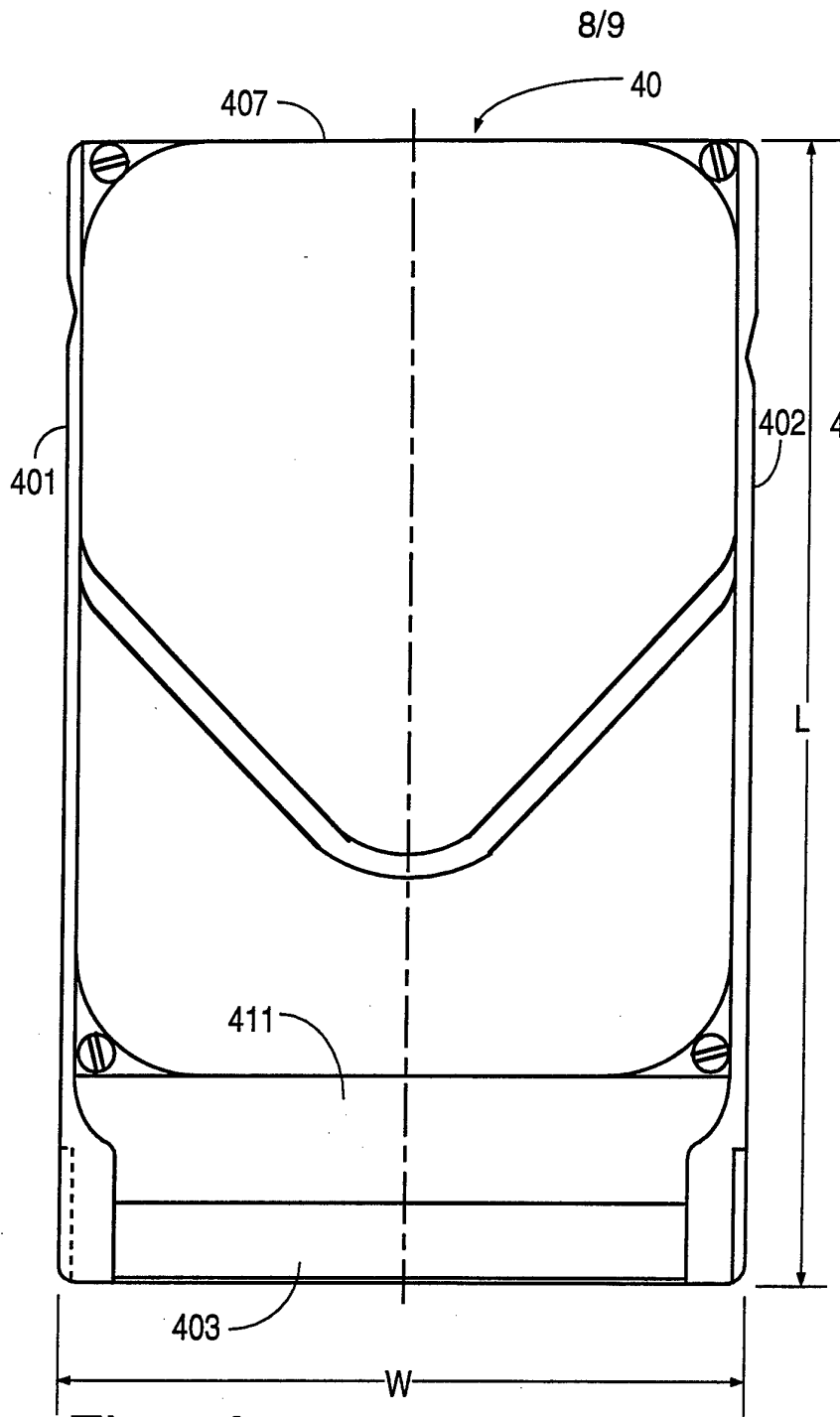

Fig. 5A

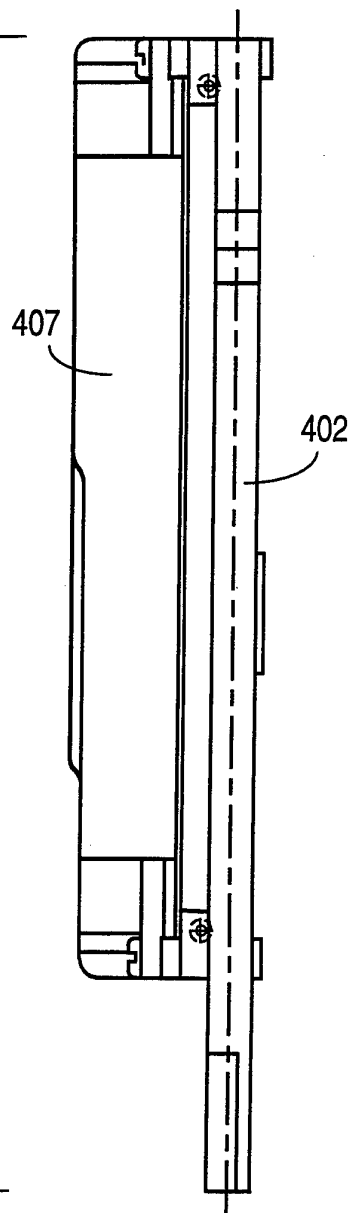

Fig. 5B

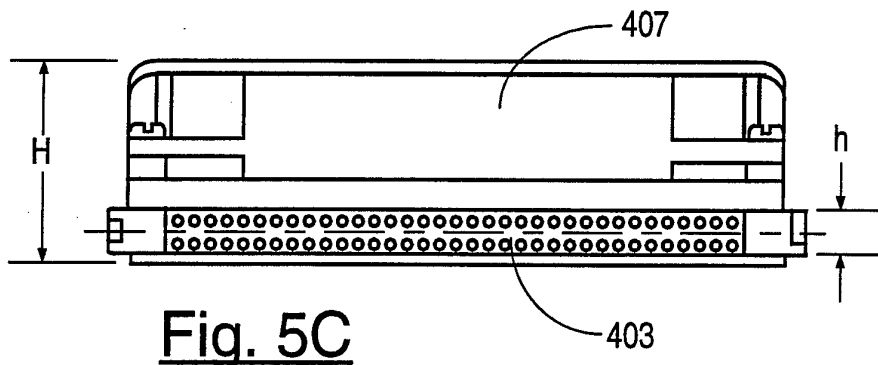

Fig. 5C

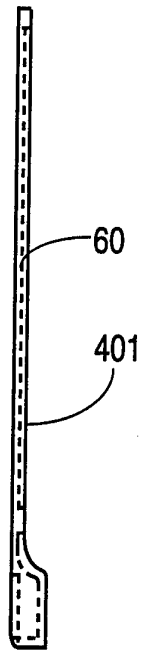

Fig. 6a

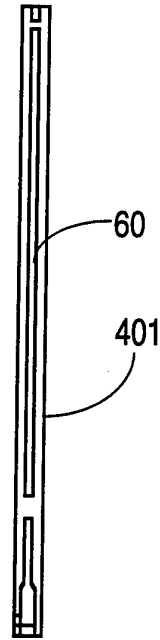

Fig. 6b

INTERNATIONAL SEARCH REPORT

International application No.
PCT/US93/09283

A. CLASSIFICATION OF SUBJECT MATTER

IPC(5) :G11B 5/012, 17/03
US CL :360/97.01

According to International Patent Classification (IPC) or to both national classification and IPC

B. FIELDS SEARCHED

Minimum documentation searched (classification system followed by classification symbols)

U.S. : 360/97.01, 97.02, 97.03, 97.04, 133, 137, 900,903

Documentation searched other than minimum documentation to the extent that such documents are included in the fields searched

Electronic data base consulted during the international search (name of data base and, where practicable, search terms used)

APS (SEARCH TERMS: disk or disc drive, rail(s), guide(s), groove(s), polarization, shield(ing))

C. DOCUMENTS CONSIDERED TO BE RELEVANT

Category*	Citation of document, with indication, where appropriate, of the relevant passages	Relevant to claim No.
X,P/Y, P	US,A, 5,179,482 (TANAKA et al) 12 January 1993, Figures 1 & 12	1,5-7,10 & 15-16 /2-4, 8-9 & 11-14
X	US,A, 5,098,175 (COOKE et al) 24 March 1992, Figure 6	1
Y,P	US,A, 5,204,794 (YOSHIDA et al) 20 April 1993, Figures 12 & 13	2-4, 8-9 & 11-14
A	US, A, 4,908,715 (KRUM et al.) 13 March 1990, fig. 1	

Further documents are listed in the continuation of Box C. See patent family annex.

* Special categories of cited documents:	"T" later document published after the international filing date or priority date and not in conflict with the application but cited to understand the principle or theory underlying the invention
"A" document defining the general state of the art which is not considered to be part of particular relevance	"X" document of particular relevance; the claimed invention cannot be considered novel or cannot be considered to involve an inventive step when the document is taken alone
"E" earlier document published on or after the international filing date	"Y" document of particular relevance; the claimed invention cannot be considered to involve an inventive step when the document is combined with one or more other such documents, such combination being obvious to a person skilled in the art
"L" document which may throw doubts on priority claim(s) or which is cited to establish the publication date of another citation or other special reason (as specified)	"&" document member of the same patent family
"O" document referring to an oral disclosure, use, exhibition or other means	
"P" document published prior to the international filing date but later than the priority date claimed	

Date of the actual completion of the international search 22 November 1993	Date of mailing of the international search report 08 DEC 1993
Name and mailing address of the ISA/US Commissioner of Patents and Trademarks Box PCT Washington, D.C. 20231 Facsimile No. NOT APPLICABLE	Authorized officer STUART S. LEVY <i>Smilla</i> Telephone No. (703) 308-1295