

**(12) PATENT APPLICATION**  
**(19) AUSTRALIAN PATENT OFFICE**

**(11) Application No. AU 200048862 A1**

(54) Title  
**Methods and apparatus for completing wells in unconsolidated subterranean zones**

(51)<sup>7</sup> International Patent Classification(s)  
**E21B 043/08**

(21) Application No: **200048862**

(22) Application Date: **2000.07.26**

(30) Priority Data

(31) Number	(32) Date	(33) Country
<b>09361714</b>	<b>1999.07.27</b>	<b>US</b>

(43) Publication Date : **2001.02.01**

(43) Publication Journal Date : **2001.02.01**

(71) Applicant(s)  
**Halliburton Energy Services, Inc.**

(72) Inventor(s)  
**Philip D. Nguyen; Ronald G. Dusterhoft**

(74) Agent/Attorney  
**CALLINAN LAWRIE, Private Bag 7, KEW VIC 3101**

ABSTRACT OF THE DISCLOSURE

METHODS AND APPARATUS FOR COMPLETING WELLS IN  
UNCONSOLIDATED SUBTERRANEAN ZONES

Improved methods and apparatus for completing an unconsolidated subterranean zone penetrated by a well bore are provided. The methods basically comprise the steps of placing a slotted liner having an internal sand screen disposed therein in the zone, isolating the slotted liner and the well bore in the zone and injecting particulate material into the annuli between the sand screen and the slotted liner and the slotted liner and the well bore to thereby form packs of particulate material therein to prevent the migration of fines and sand with produced fluids.

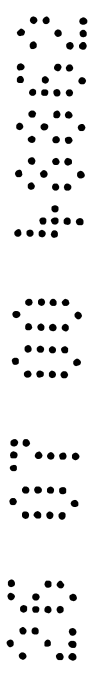

The claims defining the invention are as follows:

1. An improved method of completing an unconsolidated subterranean zone subject to migration of formation fines and sand with produced fluids penetrated by a well bore having an upper and lower end comprising the steps of:

(a) placing in a lower end of said well bore in said zone a slotted liner having open slots therein and having an internal sand screen disposed therein whereby a first annulus is formed between said sand screen and said slotted liner and a second annulus is formed between said slotted liner and said lower well bore end ;

(b) isolating said second annulus between said slotted liner and said lower well bore end in said zone from said upper well bore end ; and

(c) injecting particulate material into either or both said first annulus between said sand screen and said slotted liner and said second annulus between said slotted liner and said well bore whereby said particulate material is caused to be packed in said first and second annuli by movement through the open slots in said slotted liner and the migration of formation fines and sand with fluids produced into said well bore from said zone is prevented upon subsequent production of fluids from said subterranean zone.

2. The method of claim 1 wherein said particulate material is sand.

+

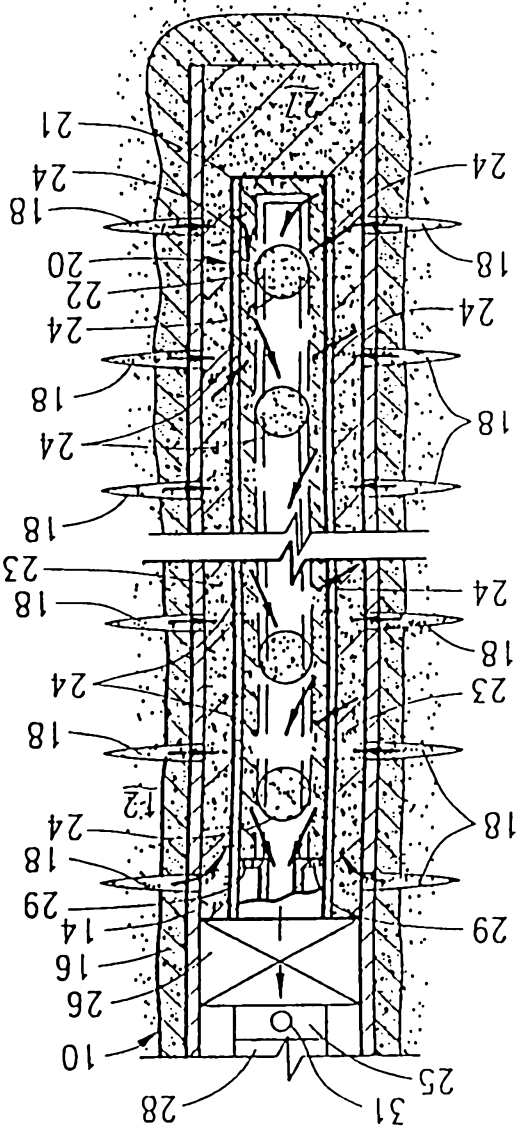
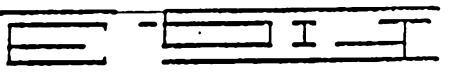
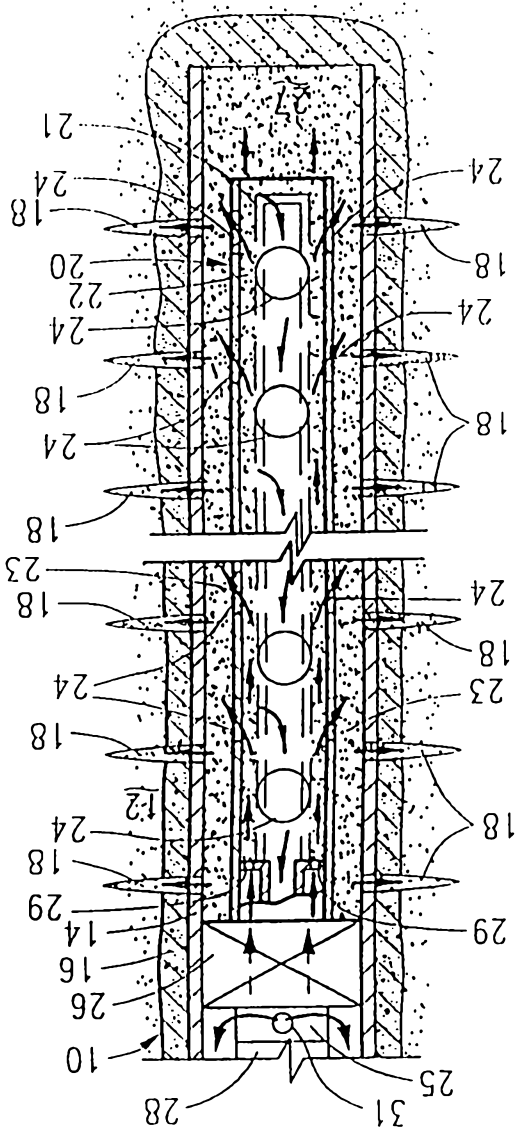
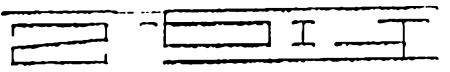
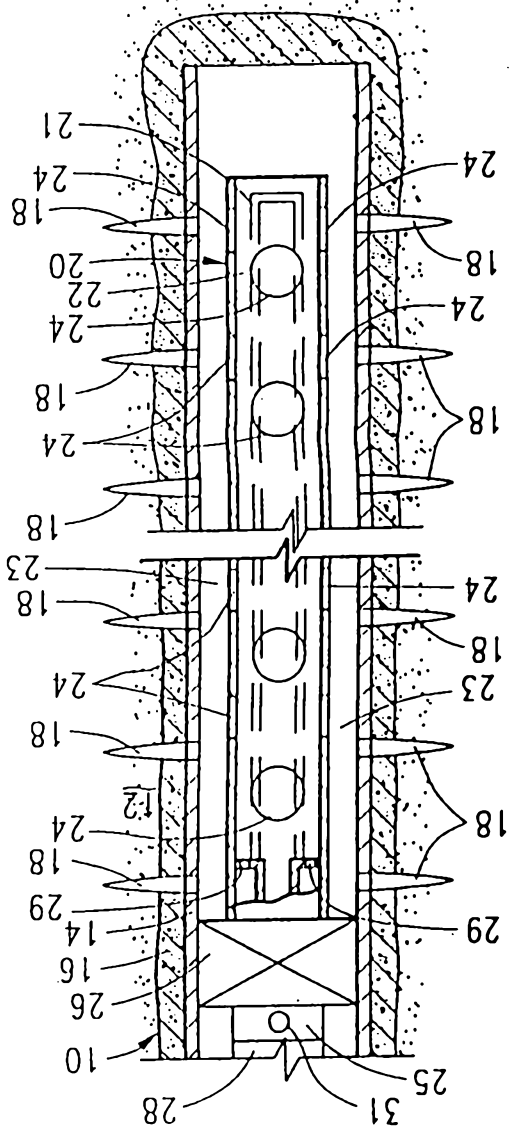
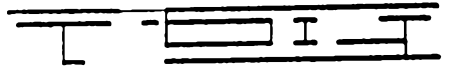

1/2

+

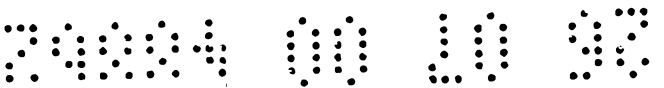

**AUSTRALIA**

**Patents Act 1990**

**COMPLETE SPECIFICATION**

**FOR A STANDARD PATENT**

**ORIGINAL**

---

**TO BE COMPLETED BY APPLICANT**

**Name of Applicant:** HALLIBURTON ENERGY SERVICES, INC.

**Actual Inventors:** PHILIP D. NGUYEN, RONALD G. DUSTERHOFT

**Address for Service:** CALLINAN LAWRIE, 711 High Street, Kew, Victoria 3101, Australia

**Invention Title:** METHODS AND APPARATUS FOR COMPLETING WELLS IN  
UNCONSOLIDATED SUBTERRANEAN ZONES

The following statement is a full description of this invention, including the best method of performing it known to me:-

---

METHODS AND APPARATUS FOR COMPLETING WELLS IN  
UNCONSOLIDATED SUBTERRANEAN ZONES

BACKGROUND OF THE INVENTION

1. Field of the Invention.

The present invention relates to improved methods and apparatus for completing wells in unconsolidated subterranean zones, and more particularly, to improved methods and apparatus for completing such wells whereby the migration of fines and sand with the fluids produced therefrom is prevented.

2. Description of the Prior Art.

Oil and gas wells are often completed in unconsolidated formations containing loose and incompetent fines and sand which migrate with fluids produced by the wells. The presence of formation fines and sand in the produced fluids is disadvantageous and undesirable in that the particles abrade pumping and other producing equipment and reduce the fluid production capabilities of the producing zones in the wells.

Heretofore, unconsolidated subterranean zones have been stimulated by creating fractures in the zones and depositing particulate proppant material in the fractures to maintain them in open positions. In addition, the proppant has heretofore been consolidated within the fractures into hard permeable masses to reduce the migration of formation fines and sands through the fractures with produced fluids. Further, gravel packs which include sand screens and the like have commonly been installed in the well bores penetrating unconsolidated zones. The gravel packs serve as filters and help to assure

that fines and sand do not migrate with produced fluids into the well bores.

In a typical gravel pack completion, a screen is placed in the well bore and positioned within the unconsolidated subterranean zone which is to be completed. The screen is typically connected to a tool which includes a production packer and a cross-over, and the tool is in turn connected to a work or production string. A particulate material which is usually graded sand, often referred to in the art as gravel, is pumped in a slurry down the work or production string and through the cross over whereby it flows into the annulus between the screen and the well bore. The liquid forming the slurry leaks off into the subterranean zone and/or through the screen which is sized to prevent the sand in the slurry from flowing therethrough. As a result, the sand is deposited in the annulus around the screen whereby it forms a gravel pack. The size of the sand in the gravel pack is selected such that it prevents formation fines and sand from flowing into the well bore with produced fluids.

A problem which is often encountered in forming gravel packs, particularly gravel packs in long and/or deviated unconsolidated producing intervals, is the formation of sand bridges in the annulus. That is, non-uniform sand packing of the annulus between the screen and the well bore often occurs as a result of the loss of carrier liquid from the sand slurry into high permeability portions of the subterranean zone which in turn causes the formation of sand bridges in the annulus

before all the sand has been placed. The sand bridges block further flow of the slurry through the annulus which leaves avoids in the annulus. When the well is placed on production, the flow of produced fluids is concentrated through the voids in the gravel pack which soon causes the screen to be eroded and the migration of fines and sand with the produced fluids to result.

In attempts to prevent the formation of sand bridges in gravel pack completions, special screens having internal shunt tubes have been developed and used. While such screens have achieved varying degrees of success in avoiding sand bridges, they, along with the gravel packing procedure, are very costly.

Thus, there are needs for improved methods and apparatus for completing wells in unconsolidated subterranean zones whereby the migration of formation fines and sand with produced fluids can be economically and permanently prevented while allowing the efficient production of hydrocarbons from the unconsolidated producing zone.

#### SUMMARY OF THE INVENTION

The present invention provides improved methods and apparatus for completing wells, and optionally simultaneously fracture stimulating the wells, in unconsolidated subterranean zones which meet the needs described above and overcome the deficiencies of the prior art. The improved methods basically comprise the steps of placing a slotted liner having an internal sand screen disposed therein whereby an annulus is formed between the sand screen and the slotted liner in an



unconsolidated subterranean zone, isolating the annulus between the slotted liner and the well bore in the zone, injecting particulate material into the annulus between either or both the sand screen and the slotted liner and the liner and the zone by way of the slotted liner whereby the particulate material is uniformly packed into the annuli between the sand screen and the slotted liner and between the slotted liner and the zone. The permeable pack of particulate material formed prevents the migration of formation fines and sand with fluids produced into the well bore from the unconsolidated zone.

As mentioned, the unconsolidated formation can be fractured prior to or during the injection of the particulate material into the unconsolidated producing zone, and the particulate material can be deposited in the fractures as well as in the annuli between the sand screen and the slotted liner and between the slotted liner and the well bore.

The apparatus of this invention are basically comprised of a slotted liner having an internal sand screen disposed therein whereby an annulus is formed between the sand screen and the slotted liner, a cross-over adapted to be connected to a production string attached to the slotted liner and sand screen and a production packer attached to the cross-over.

The improved methods and apparatus of this invention avoid the formation of sand bridges in the annulus between the slotted liner and the well bore thereby producing a very effective sand screen for preventing the migration of fines and sand with produced fluids.

It is, therefore, a general object of the present invention to provide improved methods of completing wells in unconsolidated subterranean zones.

Other and further objects, features and advantages of the present invention will be readily apparent to those skilled in the art upon a reading of the description of preferred embodiments which follows when taken in conjunction with the accompanying drawings.

#### BRIEF DESCRIPTION OF THE DRAWINGS

FIGURE 1 is a side-cross sectional view of a well bore penetrating an unconsolidated subterranean producing zone having casing cemented therein and having a slotted liner with an internal sand screen, a production packer and a cross-over connected to a production string disposed therein.

FIGURE 2 is a side cross sectional view of the well bore of FIGURE 1 after particulate material has been packed therein.

FIGURE 3 is a side cross sectional view of the well bore of FIGURE 1 after the well has been placed on production.

FIGURE 4 is a side cross sectional view of a horizontal open-hole well bore penetrating an unconsolidated subterranean producing zone having a slotted liner with an internal sand screen, a production packer and a cross-over connected to a production string disposed therein.

FIGURE 5 is a side cross sectional view of the horizontal open hole well bore of FIGURE 4 after particulate material has been packed therein.

## DESCRIPTION OF PREFERRED EMBODIMENTS

The present invention provides improved methods of completing, and optionally simultaneously fracture stimulating, an unconsolidated subterranean zone penetrated by a well bore. The methods can be performed in either vertical or horizontal well bores which are open-hole or have casing cemented therein. The term "vertical well bore" is used herein to mean the portion of a well bore in an unconsolidated subterranean producing zone to be completed which is substantially vertical or deviated from vertical in an amount up to about 15°. The term "horizontal well bore" is used herein to mean the portion of a well bore in an unconsolidated subterranean producing zone to be completed which is substantially horizontal or at an angle from vertical in the range of from about 15° to about 75°.

Referring now to the drawings and particularly to FIGURES 1-3, a vertical well bore 10 having casing 14 cemented therein is illustrated extending into an unconsolidated subterranean zone 12. The casing 14 is bonded within the well bore 10 by a cement sheath 16. A plurality of spaced perforations 18 produced in the well bore 10 utilizing conventional perforating gun apparatus extend through the casing 14 and cement sheath 16 into the unconsolidated producing zone 12.

In accordance with the methods of the present invention a slotted liner 20 having an internal sand screen 21 installed therein whereby an annulus 22 is formed between the sand screen

21 and the slotted liner 20 is placed in the well bore 10. The slotted liner 20 and sand screen 21 have lengths such that they substantially span the length of the producing interval in the well bore 10. The slotted liner 20 is of a diameter such that when it is disposed within the well bore 10 an annulus 23 is formed between it and the casing 14. The slots 24 in the slotted liner 20 can be circular as illustrated in the drawings, or they can be rectangular or other shape. Generally, when circular slots are utilized they are at least 1/2" in diameter, and when rectangular slots are utilized they are at least 3/8" wide by 2" long.

As shown in FIGURES 1-3, the slotted liner 20 and sand screen 21 are connected to a cross-over 25 which is in turn connected to a production string 28. A production packer 26 is attached to the cross-over 25. The cross-over 25 and production packer 26 are conventional gravel pack forming tools and are well known to those skilled in the art. The cross-over 25 is a sub-assembly which allows fluids to follow a first flow pattern whereby particulate material suspended in a slurry can be packed in the annuli between the sand screen 21 and the slotted liner 20 and between the slotted liner 20 and the well bore 10. That is, as shown by the arrows in FIGURE 2, the particulate material suspension flows from inside the production string 28 to the annulus 22 between the sand screen 21 and slotted liner 20 by way of two or more ports 29 in the cross-over 25. Simultaneously, fluid is allowed to flow from inside the sand screen 21 upwardly through the cross-over 25 to

the other side of the packer 26 outside of the production string 28 by way of one or more ports 31 in the cross-over 25.

By pipe movement or other procedure, flow through the cross-over 25 can be selectively changed to a second flow pattern (shown in FIGURE 3) whereby fluid from inside the sand screen 20 flows directly into the production string 28 and the ports 31 are shut off. The production packer 26 is set by pipe movement or other procedure whereby the annulus 23 is sealed.

After the slotted liner 20 and sand screen 21 are placed in the well bore 10, the annulus 23 between the slotted liner 20 and the casing 14 is isolated by setting the packer 26 in the casing 14 as shown in FIGURE 1. Thereafter, as shown in FIGURE 2, a slurry of particulate material 27 is injected into the annulus 22 between the sand screen 21 and the slotted liner 20 by way of the ports 29 in the cross-over 25 and into the annulus 23 between the slotted liner 20 and the casing 14 by way of the slots 24 in the slotted liner 20. The particulate material flows into the perforations 18 and fills the interior of the casing 14 below the packer 26 except for the interior of the sand screen 21. That is, as shown in FIGURE 2, a carrier liquid slurry of the particulate material 27 is pumped from the surface through the production string 28 and through the cross-over 25 into annulus 22 between the sand screen 21 and the slotted liner 20. From the annulus 22, the slurry flows through the slots 24 and through the open end of the slotted liner 20 into the annulus 23 and into the perforations 18. The carrier liquid in the slurry leaks off through the perforations

18 into the unconsolidated zone 12 and through the screen 21 from where it flows through cross-over 25 and into the casing 14 above the packer 26 by way of the ports 31. This causes the particulate material 27 to be uniformly packed in the perforations 18, in the annulus 23 between the slotted liner 20 and the casing 14 and within the annulus 22 between the sand screen 21 and the interior of the slotted liner 20.

Alternatively, the upper end of slotted liner 20 may be open below packer 26 to receive a flow of the slurry from production string 28 such that the slurry flows into both annulus 22 and 23 substantially simultaneously from cross-over 25 or the slurry may flow into just annulus 23 and then by way of the slots 24 into annulus 22 to pack as described above.

After the particulate material has been packed into the well bore 10 as described above, the well is returned to production as shown in FIGURE 3. The pack of particulate material 27 formed filters out and prevents the migration of formation fines and sand with fluids produced into the well bore from the unconsolidated subterranean zone 12.

Referring now to Figures 4 and 5, a horizontal open-hole well bore 30 is illustrated. The well bore 30 extends into an unconsolidated subterranean zone 32 from a cased and cemented well bore 33 which extends to the surface. As described above in connection with the well bore 10, a slotted liner 34 having an internal sand screen 35 disposed therein whereby an annulus 41 is formed therebetween is placed in the well bore 30. The slotted liner 34 and sand screen 35 are connected to a cross-

over 42 which is in turn connected to a production string 40. A production packer 36 is connected to the cross-over 42 which is set within the casing 37 in the well bore 33.

In carrying out the methods of the present invention for completing the unconsolidated subterranean zone 32 penetrated by the well bore 30, the slotted liner 34 with the sand screen 35 therein is placed in the well bore 30 as shown in FIGURE 4.

The annulus 39 between the slotted liner 34 and the well bore 30 is isolated by setting the packer 36. Thereafter, a slurry of particulate material is injected into the annulus 41 between the sand screen 35 and the slotted liner 34 and by way of the slots 38 into the annulus 39 between the slotted liner 34 and the well bore 30. Because the particulate material slurry is free to flow through the slots 38 as well as the open end of the slotted liner 34, the particulate material is uniformly packed into the annulus 39 between the well bore 30 and slotted liner 34 and into the annulus 41 between the screen 35 and the slotted liner 34. The pack of particulate material 40 formed filters out and prevents the migration of formation fines and sand with fluids produced into the well bore 30 from the subterranean zone 32.

Alternatively, the upper end of slotted liner 34 near packer 36 may be open to receive a flow of the slurry from production string 40. In this instance, the slurry passing through cross-over 42 may flow into both annulus 39 and 41 substantially simultaneously or into just annulus 39 and then

by way of slots 38 and the lower open end of slotted liner 34 into annulus 41 to thereby avoid bridging.

The methods and apparatus of this invention are particularly suitable and beneficial in forming gravel packs in long-interval horizontal well bores without the formation of sand bridges. Because elaborate and expensive sand screens including shunts and the like are not required and the pack sand does not require consolidation by a hardenable resin composition, the methods of this invention are very economical as compared to prior art methods.

The particulate material utilized in accordance with the present invention is preferably graded sand which is sized based on a knowledge of the size of the formation fines and sand in the unconsolidated zone to prevent the formation fines and sand from passing through the gravel pack, i.e., the formed permeable sand pack 27 or 40. The graded sand generally has a particle size in the range of from about 10 to about 70 mesh, U.S. Sieve Series. Preferred sand particle size distribution ranges are one or more of 10-20 mesh, 20-40 mesh, 40-60 mesh or 50-70 mesh, depending on the particle size and distribution of the formation fines and sand to be screened out by the graded sand.

The particulate material carrier liquid utilized, which can also be used to fracture the unconsolidated subterranean zone if desired, can be any of the various viscous carrier liquids or fracturing fluids utilized heretofore including gelled water, oil base liquids, foams or emulsions. The foams



utilized have generally been comprised of water based liquids containing one or more foaming agents foamed with a gas such as nitrogen. The emulsions have been formed with two or more immiscible liquids. A particularly useful emulsion is comprised of a water based liquid and a liquified normally gaseous fluid such as carbon dioxide. Upon pressure release, the liquified gaseous fluid vaporizes and rapidly flows out of the formation.

The most common carrier liquid/fracturing fluid utilized heretofore which is also preferred for use in accordance with this invention is comprised of an aqueous liquid such as fresh water or salt water combined with a gelling agent for increasing the viscosity of the liquid. The increased viscosity reduces fluid loss and allows the carrier liquid to transport significant concentrations of particulate material into the subterranean zone to be completed.

A variety of gelling agents have been utilized including hydratable polymers which contain one or more functional groups such as hydroxyl, cis-hydroxyl, carboxyl, sulfate, sulfonate, amino or amide. Particularly useful such polymers are polysaccharides and derivatives thereof which contain one or more of the monosaccharides units galactose, mannose, glucoside, glucose, xylose, arabinose, fructose, glucuronic acid or pyranosyl sulfate. Various natural hydratable polymers contain the foregoing functional groups and units including guar gum and derivatives thereof, cellulose and derivatives thereof, and the like. Hydratable synthetic polymers and co-

polymers which contain the above mentioned functional groups can also be utilized including polyacrylate, polymethylacrylate, polyacrylamide, and the like.

Particularly preferred hydratable polymers which yield high viscosities upon hydration at relatively low concentrations are guar gum and guar derivatives such as hydroxypropylguar and carboxymethylguar and cellulose derivatives such as hydroxyethylcellulose, carboxymethylcellulose and the like.

The viscosities of aqueous polymer solutions of the types described above can be increased by combining cross-linking agents with the polymer solutions. Examples of cross-linking agents which can be utilized are multivalent metal salts or compounds which are capable of releasing such metal ions in an aqueous solution.

The above described gelled or gelled and cross-linked carrier liquids/fracturing fluids can also include gel breakers such as those of the enzyme type, the oxidizing type or the acid buffer type which are well known to those skilled in the art. The gel breakers cause the viscous carrier liquids/fracturing fluids to revert to thin fluids that can be produced back to the surface after they have been utilized.

The creation of one or more fractures in the unconsolidated subterranean zone to be completed in order to stimulate the production of hydrocarbons therefrom is well known to those skilled in the art. The hydraulic fracturing process generally involves pumping a viscous liquid containing

suspended particulate material into the formation or zone at a rate and pressure whereby fractures are created therein. The continued pumping of the fracturing fluid extends the fractures in the zone and carries the particulate material into the fractures. Upon the reduction of the flow of the fracturing fluid and the reduction of pressure exerted on the zone, the particulate material is deposited in the fractures and the fractures are prevented from closing by the presence of the particulate material therein.

As mentioned, the subterranean zone to be completed can be fractured prior to or during the injection of the particulate material into the zone, i.e., the pumping of the carrier liquid containing the particulate material through the slotted liner into the zone. Upon the creation of one or more fractures, the particulate material can be pumped into the fractures as well as into the perforations and into the annuli between the sand screen and slotted liner and between the slotted liner and the well bore. If desired, the particulate may be consolidated utilizing substantially any of the conventionally known hardenable resin compositions.

In order to further illustrate the methods of this invention, the following example is given.

#### EXAMPLE I

Flow tests were performed to verify the uniform packing of particulate material in the annulus between a simulated well bore and a slotted liner. The test apparatus was comprised of a 5' long by 2" diameter plastic tubing for simulating a well

bore. Ten equally spaced 5/8" diameter holes were drilled in the tubing along the length thereof to simulate perforations in a well bore. A screen was placed inside the tubing over the 5/8" holes in order to retain sand introduced into the tubing therein. No back pressure was held on the tubing so as to simulate an unconsolidated high permeability formation.

A section of 5/8" ID plastic tubing was perforated with multiple holes of 3/8" to 1/2" diameters to simulate a slotted liner. The 5/8" tubing was placed inside the 2" tubing without centralization. Flow tests were performed with the apparatus in both the vertical and horizontal positions.

In one flow test, an 8 pounds per gallon slurry of 20/40 mesh sand was pumped into the 5/8" tubing. The carrier liquid utilized was a viscous aqueous solution of hydrated hydroxypropylguar (at a 60 pound per 1000 gallon concentration). The sand slurry was pumped into the test apparatus with a positive displacement pump. Despite the formation of sand bridges at the high leak off areas (at the perforations), alternate paths were provided through the slotted tubing to provide a complete sand pack in the annulus.

In another flow test, a slurry containing two pounds per gallon of 20/40 mesh sand was pumped into the 5/8" tubing. The carrier liquid utilized was a viscous aqueous solution of hydrated hydroxypropylguar (at a concentration of 30 pounds per 1000 gallon). Sand bridges were formed at each perforation, but the slurry was still able to transport sand into the annulus and a complete sand pack was produced therein.

In another flow test, a slurry containing two pounds per gallon of 20/40 mesh sand was pumped into the test apparatus. The carrier liquid was a viscous aqueous solution of hydrated hydroxypropylguar (at a 45 pound per 1000 gallon concentration). In spite of sand bridges being formed at the perforations, a complete sand pack was produced in the annulus.

#### EXAMPLE II

Large-scale flow tests were performed using a fixture which included an acrylic casing for ease of observation of proppant transport. The acrylic casing had a 5.25" ID and a total length of 25 ft. An 18-ft. length, 4.0" ID, acrylic slotted liner with 3/4" holes at a spacing of 12 holes per foot was installed inside the casing. An 8-gauge wire-wrapped sand screen was installed inside the acrylic slotted liner. The sand screen had an O.D. of 2.75 inches and a length of 10 ft. An 18-inch segment of pipe was extended from the screen at each end. A ball valve was used to control the leakoff through the screen. However, it was fully opened during the large scale flow tests.

Two high leakoff zones in the casing were simulated by multiple 1" perforations formed therein. One zone was located close to the outlet. The other zone was located about 12 ft. from the outlet. Each perforation was covered with 60 mesh screen to retain proppant during proppant placement. Ball valves were connected to the perforations to control the fluid loss from each perforation. During the flow tests the ball valves were fully opened to allow maximum leakoff.

Two flow tests were performed to determine the packing performance of the fixture. Due to the strength of the acrylic casing, the pumping pressure could not exceed 100 psi.

In the first test, an aqueous hydroxypropyl guar linear gel having a concentration of 30 pounds per 1000 gallons was used as the carrier fluid. A gravel slurry of 20/40 mesh sand having a concentration of 2 pounds per gallon was prepared and pumped into the fixture at a pump rate of about 1/2 barrel per minute. Sand quickly packed around the wire-wrapped screen and packed off the high leakoff areas of the perforations whereby sand bridges were formed. However, the sand slurry flowed through the slots and open bottom of the slotted liner, bypassed the bridged areas and completely filled the voids resulting in a complete sand pack throughout the annuli between the sand screen and the slotted liner and between the slotted liner and the casing.

In the second test, a 45 pound per 1000 gallon aqueous hydroxypropyl guar gel was used as the carrier fluid and the sand concentration was 6 pounds per gallon of gel. The pump rate utilized was about 1/2 barrel per minute. The same type of complete sand pack was formed and observed in this test.

Thus, the present invention is well adapted to carry out the objects and attain the ends and advantages mentioned as well as those which are inherent therein. While numerous changes may be made by those skilled in the art, such changes are included in the spirit of this invention as defined by the appended claims.

:

Where the terms “comprise”, “comprises”, “comprised” or “comprising” are used in this specification, they are to be interpreted as specifying the presence of the stated features, integers, steps or components referred to, but not to preclude the presence or addition of one or more other feature, integer, step, component or group thereof.

5

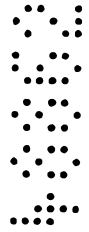

The claims defining the invention are as follows:

1. An improved method of completing an unconsolidated subterranean zone subject to migration of formation fines and sand with produced fluids penetrated by a well bore having an upper and lower end comprising the steps of:

(a) placing in a lower end of said well bore in said zone a slotted liner having open slots therein and having an internal sand screen disposed therein whereby a first annulus is formed between said sand screen and said slotted liner and a second annulus is formed between said slotted liner and said lower well bore end ;

(b) isolating said second annulus between said slotted liner and said lower well bore end in said zone from said upper well bore end ; and

(c) injecting particulate material into either or both said first annulus between said sand screen and said slotted liner and said second annulus between said slotted liner and said well bore whereby said particulate material is caused to be packed in said first and second annuli by movement through the open slots in said slotted liner and the migration of formation fines and sand with fluids produced into said well bore from said zone is prevented upon subsequent production of fluids from said subterranean zone.

2. The method of claim 1 wherein said particulate material is sand.



3. The method of claim 1 wherein said well bore in said subterranean zone is open-hole.

4. The method of claim 1 wherein said well bore in said subterranean zone has casing cemented therein with perforations formed through the casing and cement.

5. The method of claim 1 wherein said annulus is isolated in accordance with step (b) by setting a packer in said well bore.

6. The method of claim 1 which further comprises the step of creating at least one fracture in said subterranean zone prior to or while carrying out step (c).

7. The method of claim 6 which further comprises the step of depositing particulate material in said fracture.

8. An improved method of completing an unconsolidated subterranean zone subject to migration of formation fines and sand with produced fluids penetrated by an open-hole well bore having an upper and lower end comprising the steps of:

(a) placing in a lower end of said well bore in said zone a slotted liner having open slots therein and having an internal sand screen disposed therein whereby a first annulus is formed between said sand screen and said slotted liner and a second annulus is formed between said slotted liner and said lower well bore end ;

(b) isolating said second annulus between said slotted liner and said lower well bore end in said zone from said upper well bore end ;

(c) pumping a slurry of particulate material into either or both said first annulus between said sand screen and said slotted liner and said second annulus between said slotted liner and said well bore whereby said particulate material is packed in said first and second annuli by passage through the slots in said slotted liner and the migration of formation fines and sand with fluids produced into said well bore from said zone is prevented upon subsequent production of fluids from said zone; and

(e) placing said unconsolidated subterranean zone on production.

9. The method of claim 8 wherein said particulate material is sand.

10. The method of claim 8 wherein said second annulus between said slotted liner and said well bore is isolated in accordance with step (b) by setting a packer in said well bore.

11. The method of claim 8 wherein said well bore in said zone is horizontal.

12. The method of claim 8 which further comprises the step of creating at least one fracture in said subterranean zone prior to or while carrying out step (c).

13. The method of claim 11 which further comprises the step of depositing particulate material in said fracture.

14. An improved method of completing an unconsolidated subterranean zone penetrated by a well bore having an upper and

lower end and having casing cemented therein comprising the steps of:

(a) forming perforations through said casing and cement into said zone;

(b) placing in a lower end of said well bore in said zone a slotted liner having open slots therein and an internal sand screen disposed therein whereby a first annulus is formed between said sand screen and said slotted liner and a second annulus is formed between said slotted liner and said casing in said lower end of said well bore;

(c) isolating said second annulus between said slotted liner and said casing in said lower end of said well bore in said zone from said upper well bore end ;

(d) pumping a slurry of particulate material into either or both said first annulus between said sand screen and said slotted liner and said second annulus between said slotted liner and said casing whereby said particulate material is packed in said first and second annuli by passage through the slots in said slotted liner and in said perforations and the migration of formation fines and sand with fluids produced into said well bore from said zone is prevented upon subsequent production of fluids from said formation.

15. The method of claim 14 wherein said particulate material is sand.

16. The method of claim 14 wherein said second annulus between said slotted liner and said casing is isolated in accordance with step (c) by setting a packer in said casing.

17. The method of claim 14 which further comprises the step of creating at least one fracture in said subterranean zone prior to or while carrying out step (d).

18. The method of claim 17 which further comprises the step of depositing particulate material in said fracture.

DATED this 26<sup>th</sup> day of July, 2000

**HALLIBURTON ENERGY SERVICES, INC.**

By their Patent Attorneys:

CALLINAN LAWRIE

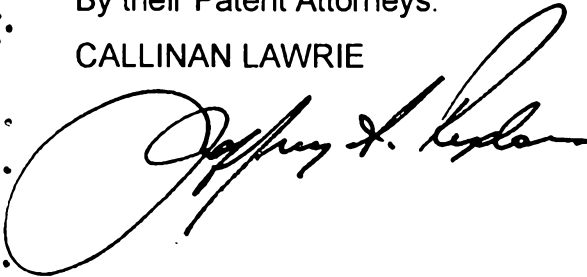
A handwritten signature in black ink, appearing to read "Jeffrey S. Lawrie", is written over the printed name "CALLINAN LAWRIE". The signature is fluid and cursive.

+

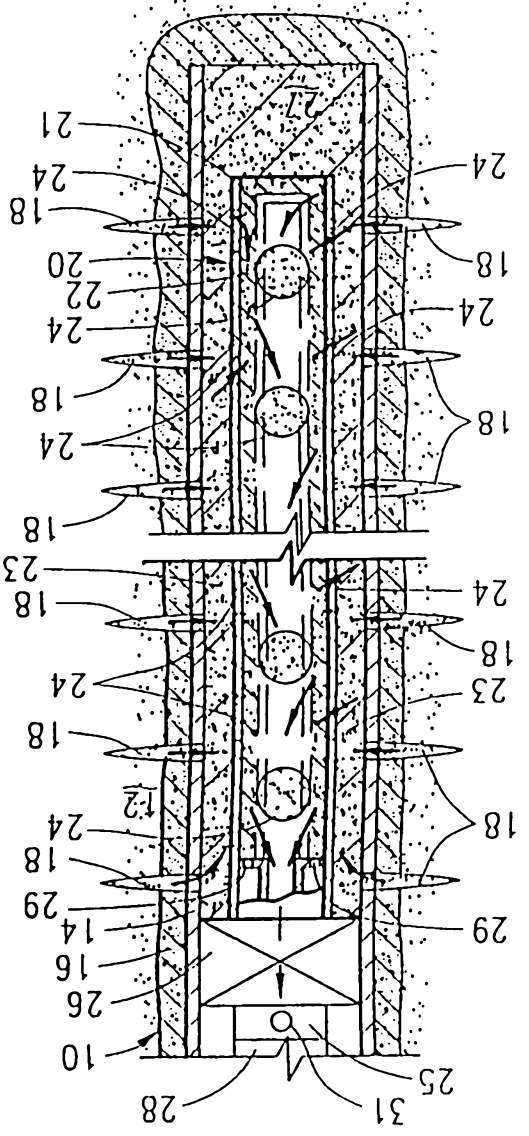
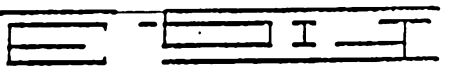
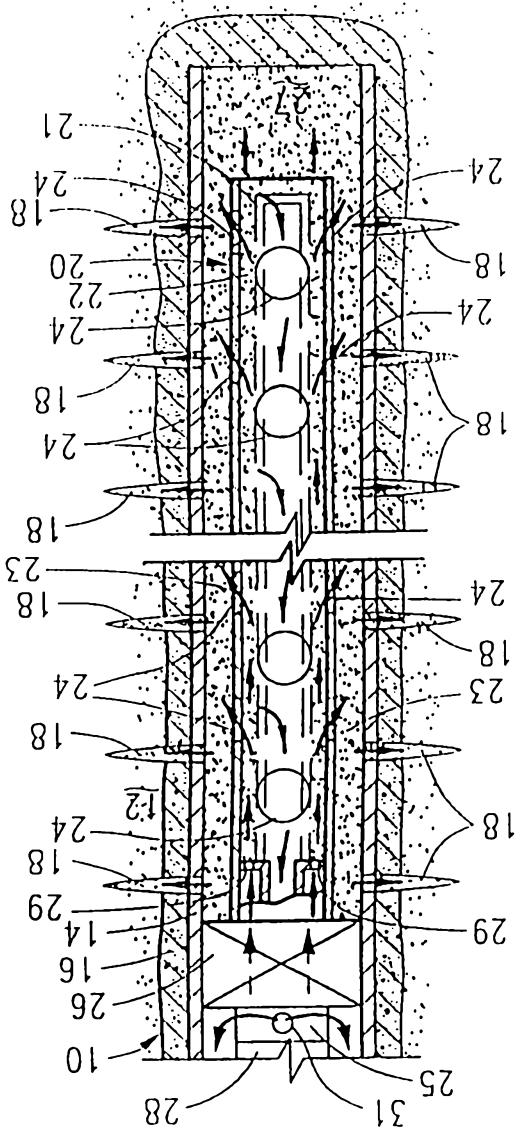
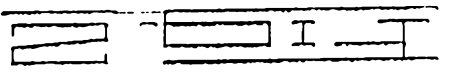
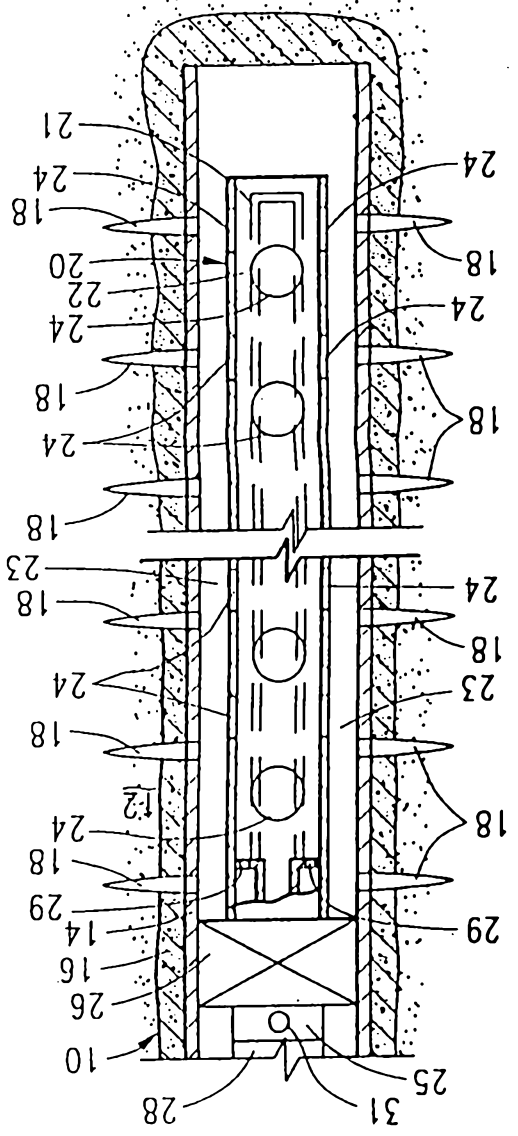
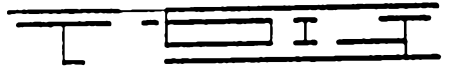

1/2

+

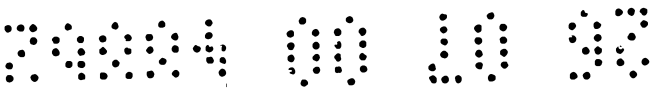

+

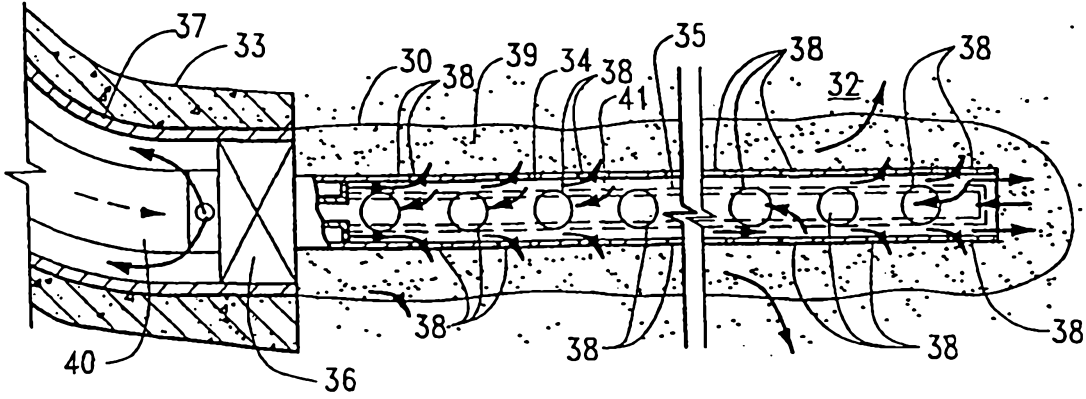

FIG. 1

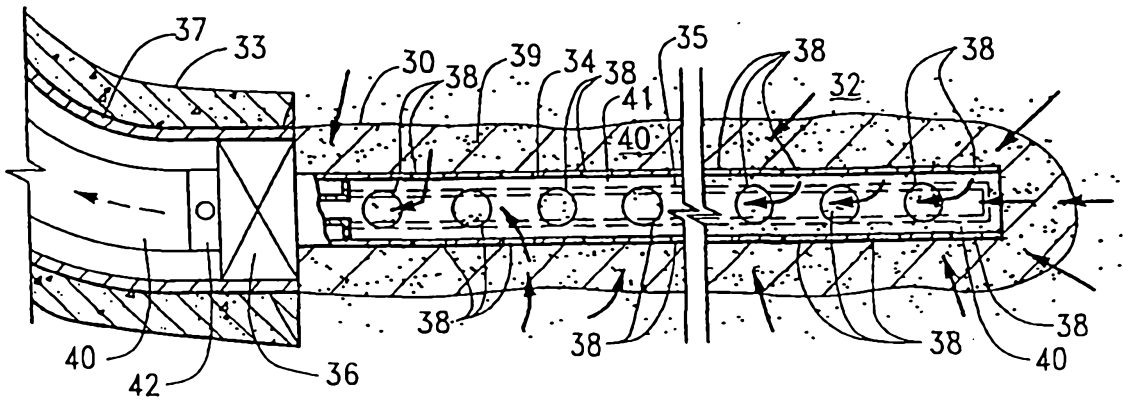

FIG. 2

+