



US007252631B2

(12) **United States Patent**  
**Tracey**

(10) **Patent No.:** **US 7,252,631 B2**  
(45) **Date of Patent:** **Aug. 7, 2007**

(54) **SYSTEM AND METHOD FOR ASSESSING  
DETRUSOR INSTABILITY**

(75) Inventor: **Michael R. Tracey**, Branchburg, NJ  
(US)

(73) Assignee: **Ethicon, Inc.**, Somerville, NJ (US)

(\* ) Notice: Subject to any disclaimer, the term of this  
patent is extended or adjusted under 35  
U.S.C. 154(b) by 878 days.

(21) Appl. No.: **10/674,452**

(22) Filed: **Sep. 30, 2003**

(65) **Prior Publication Data**

US 2004/0133067 A1 Jul. 8, 2004

**Related U.S. Application Data**

(63) Continuation-in-part of application No. 10/183,790,  
filed on Jun. 27, 2002, now Pat. No. 7,052,452.

(60) Provisional application No. 60/372,579, filed on Apr.  
12, 2002, provisional application No. 60/302,069,  
filed on Jun. 29, 2001.

(51) **Int. Cl.**

**A61F 2/00** (2006.01)

**A61B 5/00** (2006.01)

(52) **U.S. Cl.** ..... **600/29; 600/561**

(58) **Field of Classification Search** ..... **600/29-32,**  
**600/300, 561, 587-588, 591, 593; 128/897-898,**  
**128/DIG. 25**

See application file for complete search history.

(56) **References Cited**

**U.S. PATENT DOCUMENTS**

926,197 A	6/1909	Kim
1,666,332 A	4/1928	Hirsch
1,688,795 A	10/1928	Aas
1,819,368 A	8/1931	Hart
3,685,787 A	8/1972	Adelberg
3,699,964 A	10/1972	Ericson
3,789,835 A	2/1974	Whitman
3,812,841 A	5/1974	Isaacson
3,900,184 A	8/1975	Burke et al.
3,970,090 A	7/1976	Loiacono
4,022,209 A	5/1977	Nehring
4,063,548 A	12/1977	Klatt et al.
4,191,196 A	3/1980	Bradley et al.
4,216,907 A	8/1980	Fuller
4,217,911 A	8/1980	Layton
4,236,520 A	12/1980	Anderson
4,248,214 A	2/1981	Hannah et al.
4,367,740 A	1/1983	Evanoski
4,370,983 A	2/1983	Lichtenstein
4,407,301 A	10/1983	Streisinger
4,432,352 A	2/1984	Wineland
4,432,757 A	2/1984	Davis, Jr.
4,464,172 A	8/1984	Lichtenstein
4,484,585 A	11/1984	Baier
4,557,255 A	12/1985	Goodman
4,567,880 A	2/1986	Goodman
4,612,939 A	9/1986	Robertson

4,632,684 A	12/1986	Karbassiyoon et al.
4,704,102 A	11/1987	Guthery
4,731,060 A	3/1988	Catalano
4,738,659 A	4/1988	Sleiman
4,750,488 A	6/1988	Wuchinich et al.
4,813,935 A	3/1989	Haber et al.
4,816,020 A	3/1989	Brownell
4,872,483 A	10/1989	Shah
4,998,527 A	3/1991	Meyer
5,176,148 A	1/1993	Wiest et al.
5,176,664 A	1/1993	Weisman
5,331,548 A	7/1994	Rollema et al.
5,342,298 A	8/1994	Michaels et al.
5,377,101 A	12/1994	Rollema
5,385,563 A	1/1995	Gross
5,433,216 A	7/1995	Sugrue et al.
5,449,345 A	9/1995	Taylor et al.
5,480,417 A	1/1996	Hascoet et al.
5,520,636 A	5/1996	Korth et al.
5,566,680 A	10/1996	Urion et al.
5,590,648 A	1/1997	Mitchell et al.
5,623,925 A	4/1997	Swenson et al.
5,624,395 A	4/1997	Mikhail et al.
5,674,238 A	10/1997	Sample et al.
5,688,239 A	11/1997	Walker
5,722,931 A	3/1998	Heaven
5,733,230 A	3/1998	Sawchuck et al.

(Continued)

**FOREIGN PATENT DOCUMENTS**

DE 42 34 640 A 4/1994

(Continued)

**OTHER PUBLICATIONS**

Bors, "A Simple Sphincterometer", *Journal of Urology*, Baltimore,  
MD, US, vol. 60, No. 2 (Aug. 1948) pp. 287-289, ISSN: 0022-5347  
(XP008071361).

(Continued)

*Primary Examiner*—John P. Lacyk

(57) **ABSTRACT**

A method is provided for diagnosing detrusor instability. The method includes using an insert member having a channel therethrough positioned distal of the urethral sphincter, creating a substantially fluid tight seal to substantially block fluid flow into or out of the urethral canal other than through the channel, infusing fluid from a fluid source through the channel in the insert member and into the urethral canal at a location distal of the urethral sphincter, and measuring a pressure within the urethral canal at a location distal of the urethral sphincter as the fluid is being infused therein. The infusing step further involves infusing fluid until the urethral sphincter opens, and thereafter until at least one detrusor contraction occurs.

## U.S. PATENT DOCUMENTS

5,772,628 A 6/1998 Bacich et al.  
 5,788,631 A 8/1998 Fiddian-Green  
 5,792,042 A 8/1998 Cohen et al.  
 5,800,407 A 9/1998 Eldor  
 5,823,972 A 10/1998 McRae  
 5,855,549 A 1/1999 Newman  
 5,858,003 A 1/1999 Atala  
 5,865,815 A 2/1999 Tihon  
 5,868,135 A 2/1999 Kaufman  
 5,887,593 A 3/1999 Levius  
 5,924,984 A 7/1999 Rao  
 5,954,696 A 9/1999 Ryan  
 5,997,474 A 12/1999 Batchelor  
 6,001,060 A 12/1999 Churchill et al.  
 6,004,305 A 12/1999 Hursman et al.  
 6,021,781 A 2/2000 Thompson et al.  
 6,022,955 A 2/2000 Sarin et al.  
 6,048,308 A 4/2000 Strong  
 6,056,699 A 5/2000 Sohn et al.  
 6,063,045 A 5/2000 Wax et al.  
 6,071,230 A 6/2000 Henalla  
 6,086,549 A 7/2000 Nelse et al.  
 6,110,099 A 8/2000 Benderev  
 6,119,697 A 9/2000 Engel et al.  
 6,120,438 A 9/2000 Rizvi  
 6,129,330 A 10/2000 Guala  
 6,156,017 A 12/2000 Shieh  
 6,162,201 A 12/2000 Cohen et al.  
 6,258,060 B1 7/2001 Willard  
 6,258,087 B1 7/2001 Edwards  
 6,283,987 B1 9/2001 Laird  
 6,315,711 B1 11/2001 Conway et al.  
 6,358,229 B1 3/2002 Tihon  
 6,396,416 B1 5/2002 Kuusela et al.  
 6,434,418 B1 8/2002 Neal et al.  
 6,447,462 B1 9/2002 Wallace et al.  
 6,461,332 B1 10/2002 Mosel et al.  
 6,579,266 B2 6/2003 Mosel et al.  
 6,666,828 B2 12/2003 Greco et al.  
 6,699,175 B2 3/2004 Miller  
 6,719,709 B2 4/2004 Whalen et al.  
 6,720,887 B1 4/2004 Zunti  
 2001/0045355 A1 11/2001 Gephart et al.  
 2002/0111586 A1 8/2002 Mosel  
 2002/0115906 A1 8/2002 Miller  
 2002/0147423 A1 10/2002 Burbank et al.  
 2002/0165521 A1 11/2002 Cioanta et al.  
 2002/0198506 A1 12/2002 Whalen et al.  
 2003/0023134 A1 1/2003 Tracey  
 2003/0023144 A1 1/2003 Tracey et al.  
 2003/0027326 A1 2/2003 Ulmsten et al.  
 2003/0028074 A1 2/2003 Tracey et al.  
 2003/0028075 A1 2/2003 Ulmsten et al.  
 2003/0028159 A1 2/2003 Tracey et al.  
 2003/0163086 A1 8/2003 Denyer et al.  
 2003/0181897 A1 9/2003 Thomas et al.  
 2003/0208183 A1 11/2003 Whalen et al.  
 2004/0176747 A1 9/2004 Feneley

## FOREIGN PATENT DOCUMENTS

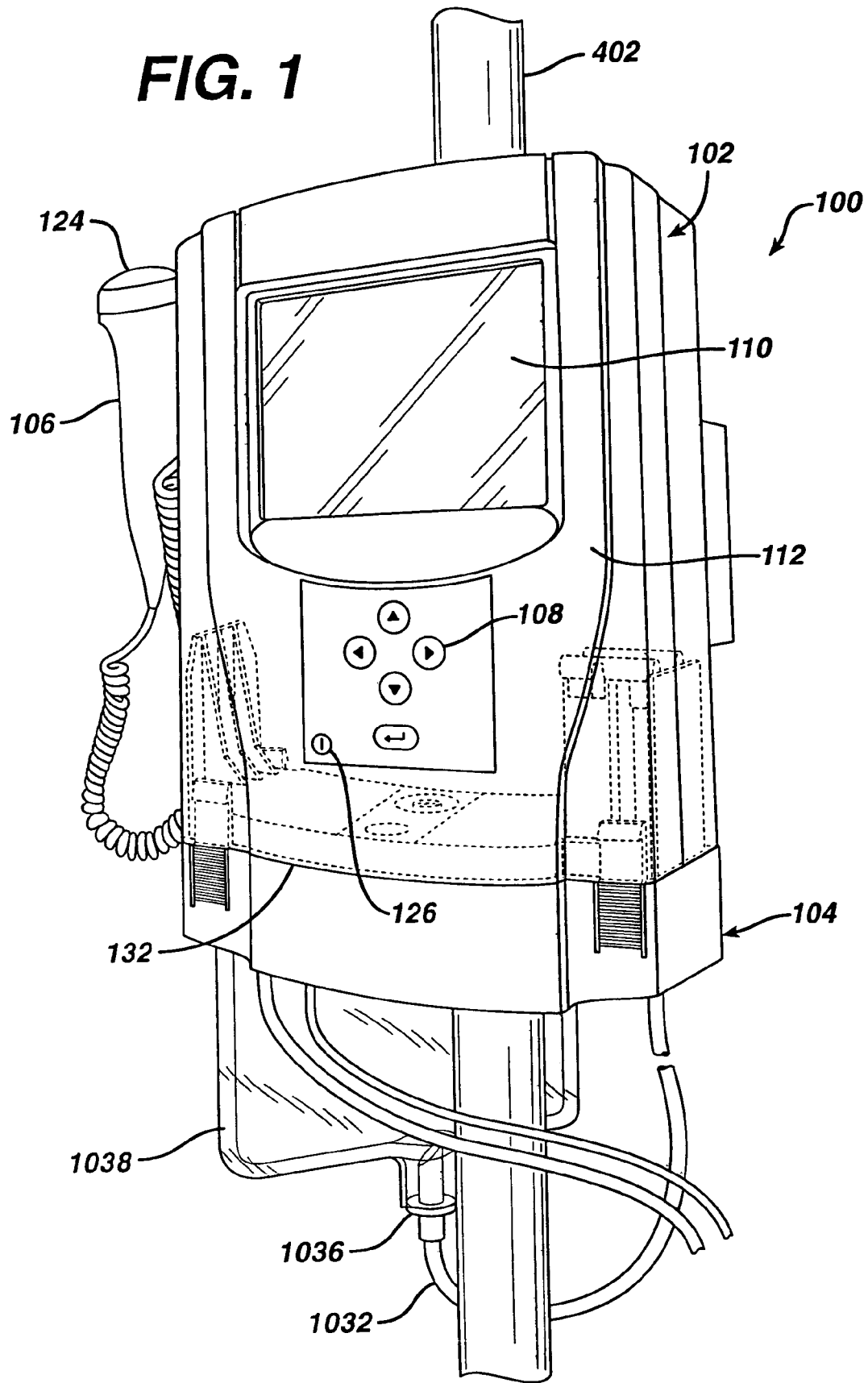
DE 196 17 854 A 11/1997  
 DE 298 15 815 U1 1/1999  
 EP 0608593 A1 8/1994  
 EP 0878166 A1 11/1998  
 GB 2 075 841 A 11/1981  
 GB 2261169 A 5/1993  
 WO WO 96/04847 A 2/1996  
 WO WO 97/17909 A 5/1997  
 WO WO 97/49077 A 12/1997

WO WO 00/23127 A1 4/2000  
 WO WO 01/17469 A 3/2001  
 WO WO 01/28607 A 4/2001

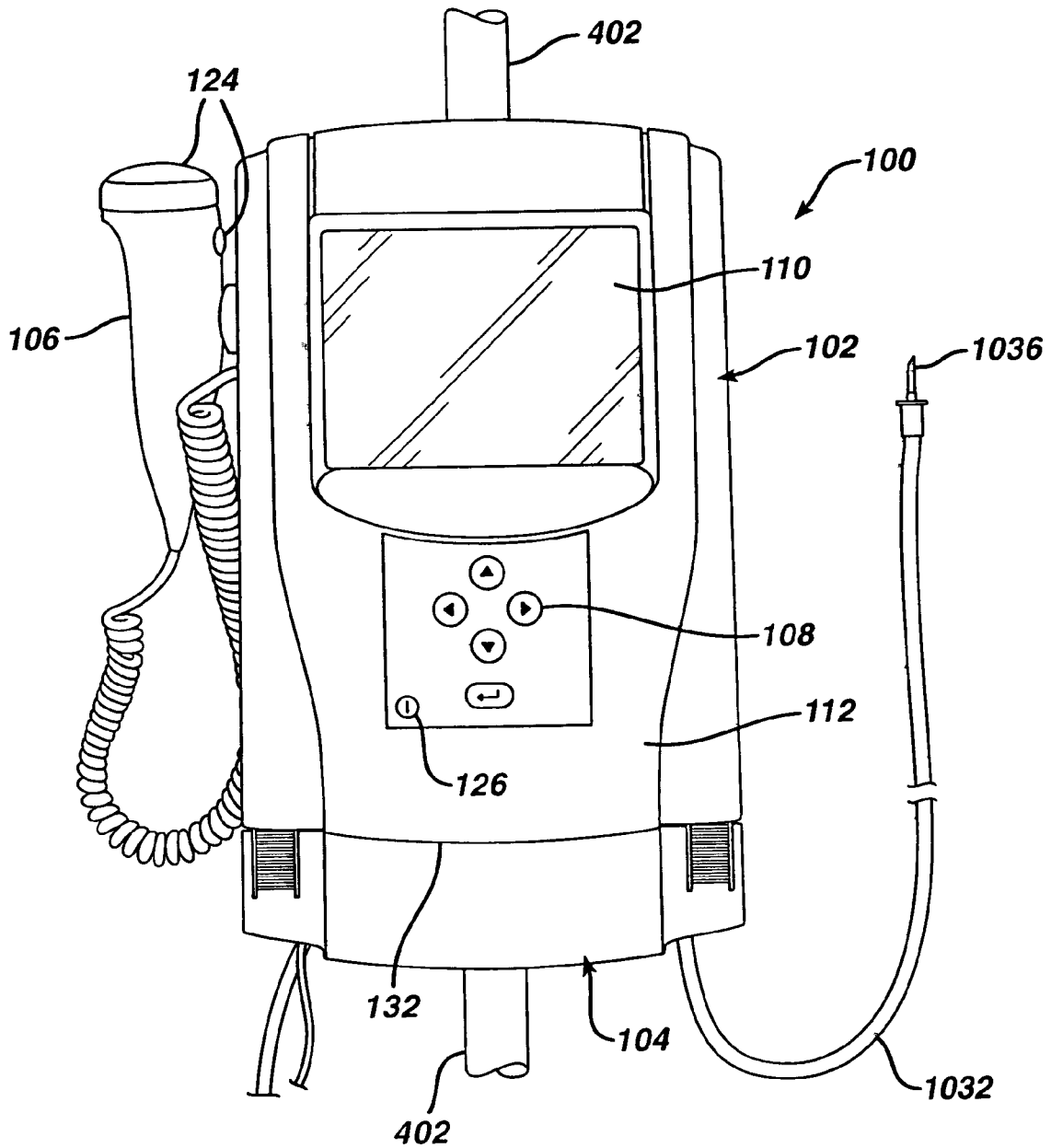
## OTHER PUBLICATIONS

Comiter et al., "Retrograde Leak Point Pressure for Evaluating Postradical Prostatectomy Incontinence", *Urology*, vol. 49, No. 2 (1997) pp. 231-236, ISSN: 0090-4295 (XP002407136).  
 Beutelspacher et al., "A Portable System for Continuous Stress-Free Measurement of Bladder Function Ein Portables System Zur Kontinuierlichen Stressfreien Aufzeichnung der Harnblasenmotorik", *Biomedizinische Technik, Fachverlag Schiele und Schoen GmbH, Berlin, DE*, vol. 30, No. 4 (Apr. 1, 1985) pp. 85-90, ISSN: 0013-5585 (XP000601891).  
 Leach et al., "Perfusion Sphincterometry Method of Intra Operative Evaluation of Artificial Urinary Sphincter Function", *Urology*, vol. 21, No. 3 (1983) pp. 312-314, ISSN: 0090-4295 (XP002407088).  
 Ordorica, Raul C. "Choosing the right urodynamic system", *Contemporary Urology*, 1996, pp. 47-64.  
 Barnes, D.G. et al., "A consumer's Guide to Commercially Available Urodynamic Equipment", *British Journal of Urology*, 1991, 68, pp. 13-143.  
 Rowan, D. et al., "Urodynamic equipment: technical aspects" *Journal of Medical Engineering & Technology*, 1987, pp. 57-64, vol. 11.  
 Surgitek® UDS-1000G, A Systems Approach, *The Journal of Urology* 1992, AUA Eighty-Seventh Annual Meeting, Washington, D.C.  
 UroBase™ The Portable Cystometer. *The Journal of Urology* 1989, No. 1, vol. 141, Annual Meeting, American Urological Association, Inc., Dallas, Texas.  
 UDS-54, The Urodynamics System, *The Journal of Urology* 1989, vol. 141, No. 4, Part 2, AUA Eighty-Fourth Annual Meeting, Dallas, Texas.  
 Bard 4-Channel Urodynamic Monitor, A Breakthrough In Urodynamic Technology, Bard Urological Division, C.R. Bard, Inc. 1995.  
 Market Engineering Research for the U.S. UI Urodynamic Equipment Market, Frost & Sullivan 1998.  
 The Dantec Duet™, 510(k) Summary of Safety and Effectiveness (1996).  
 The Lumax Fiber Optic Pressure Monitoring System, 510(k) Summary, 1995.  
 Petros, P.E.P. et al., An Integral Theory And Its Method For The Diagnosis And Management Of Female Urinary Incontinence, *Scandinavian Journal of Urology and Nephrology*, 1993, Supplement 153.  
 Lane, T.M. et al., Leak-point pressures, *BJU International* 2000, vol. 86, pp. 942-949.  
 McLennan, M.T. et al., Leak-Point Pressure: Clinical Application of Values at Two Different Volumes, *International Urogynecology Journal*, 2000, vol. 11, pp. 136-141.  
 Petros, P.E.P. et al., An Anatomical Classification—a New Paradigm for Management of Urinary Dysfunction in the Female, *International Urogynecology Journal*, 1999, vol. 10, pp. 29-35.  
 Petros, P.E.P. et al., An anatomical classification—a new paradigm for management of female lower urinary tract dysfunction, *European Journal of Obstetrics & Gynecology and Reproductive Biology*, 1998, vol. 80, pp. 87-94.  
 Kim, K.J. et al., The Vesico-Urethral Pressuregram analysis Of Urethral Function Under Stress, 1997, vol. 30, No. 1, pp. 19-25.  
 Sanchez-Doblado, F. et al., Computerized analysis of urological parameters, *Medical & Biological Engineering & Computing*, 1988, vol. 26, pp. 325-327.  
 Kim, K.-J. et al., Principles of urodynamics pressure measurement and its implication to female continence function, *Journal of Biomechanics*, 1998, vol. 31, pp. 861-865.  
 Lumaxpro Fiberoptic Cystometry System, Cooper Surgical, Shelton, CT, Oct. 2001.  
 Bonney et al., Historical Presentation, Berlin-Brandenburgische 2002.

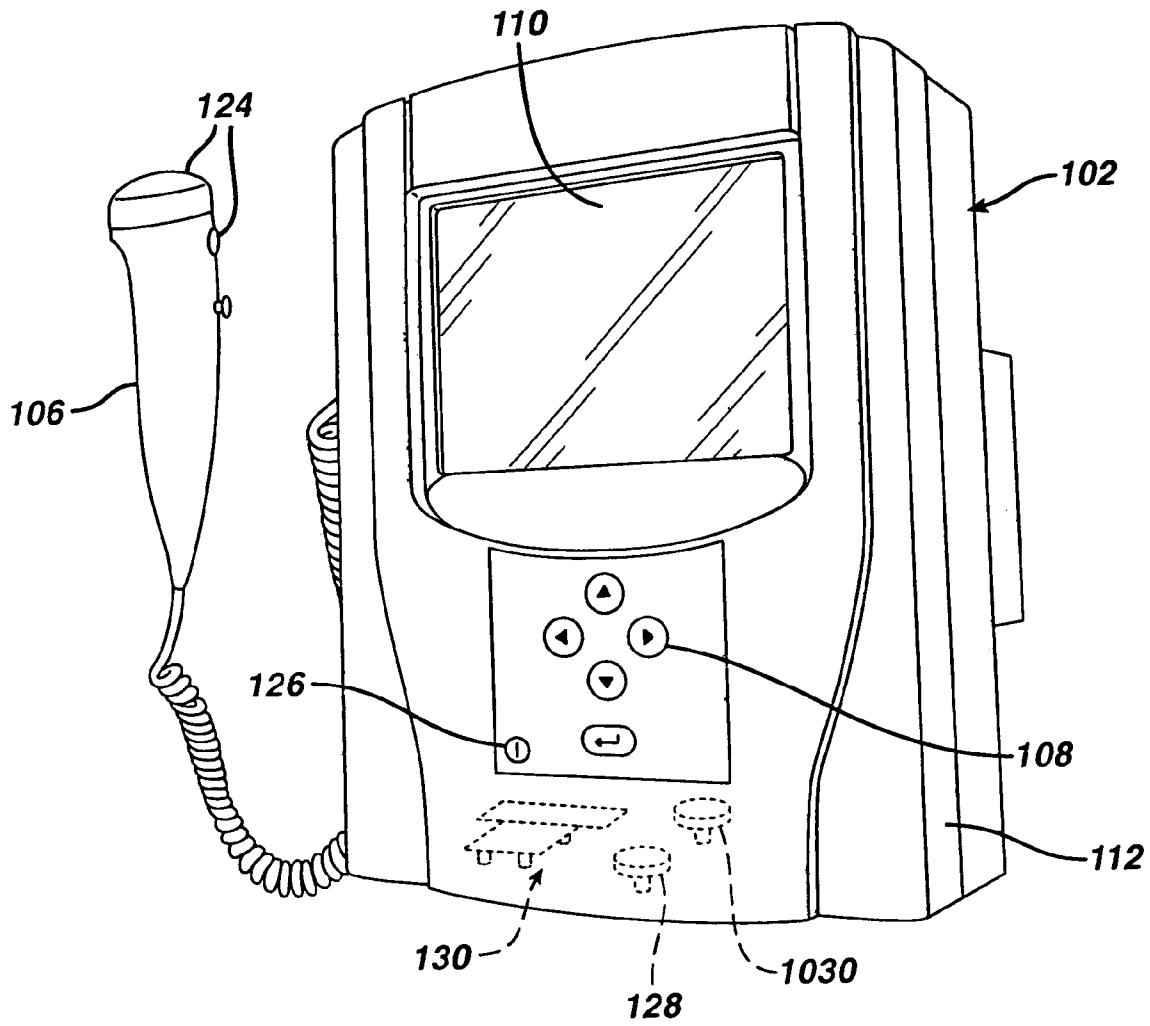
**FIG. 1**



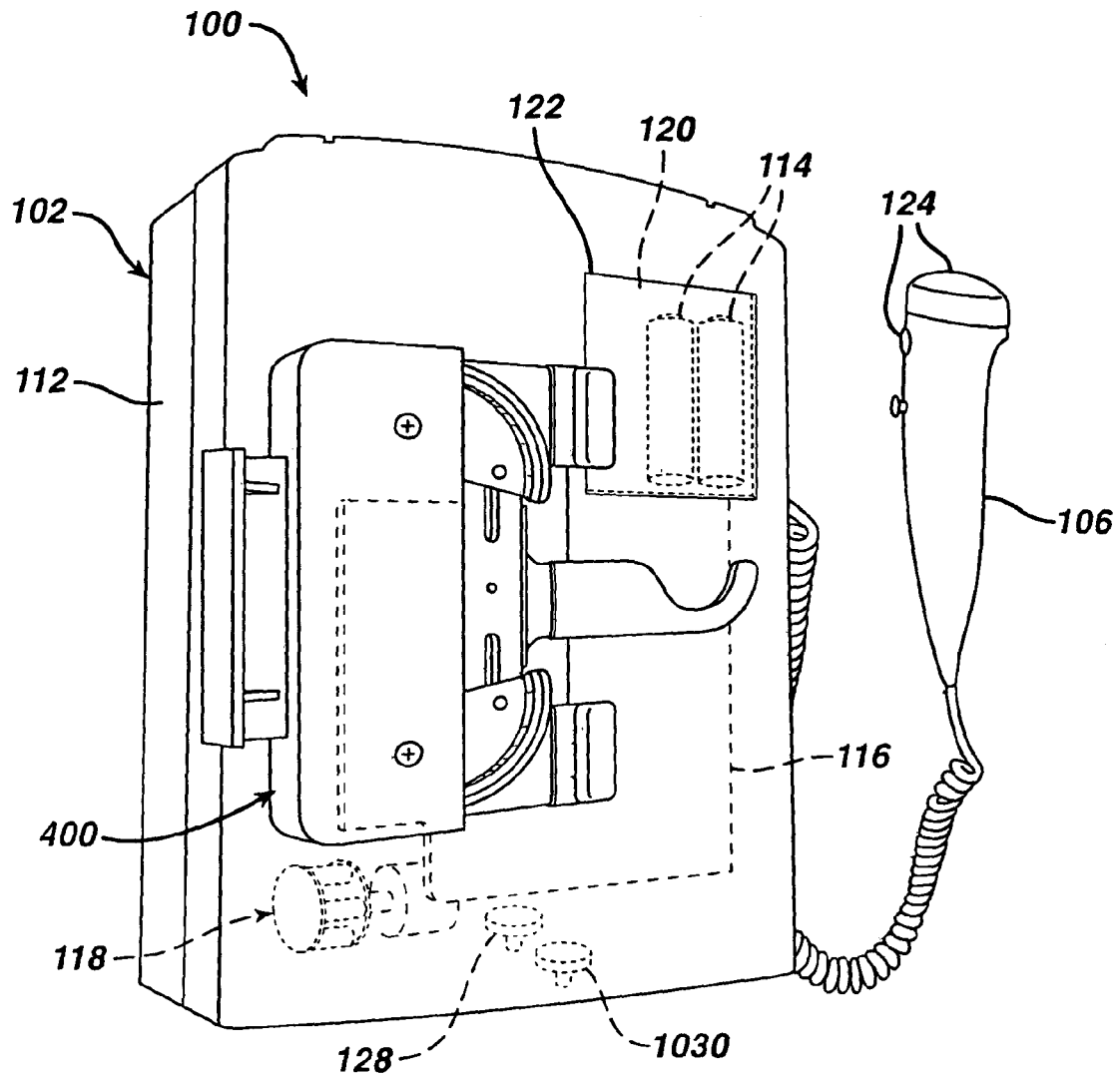
**FIG. 1a**



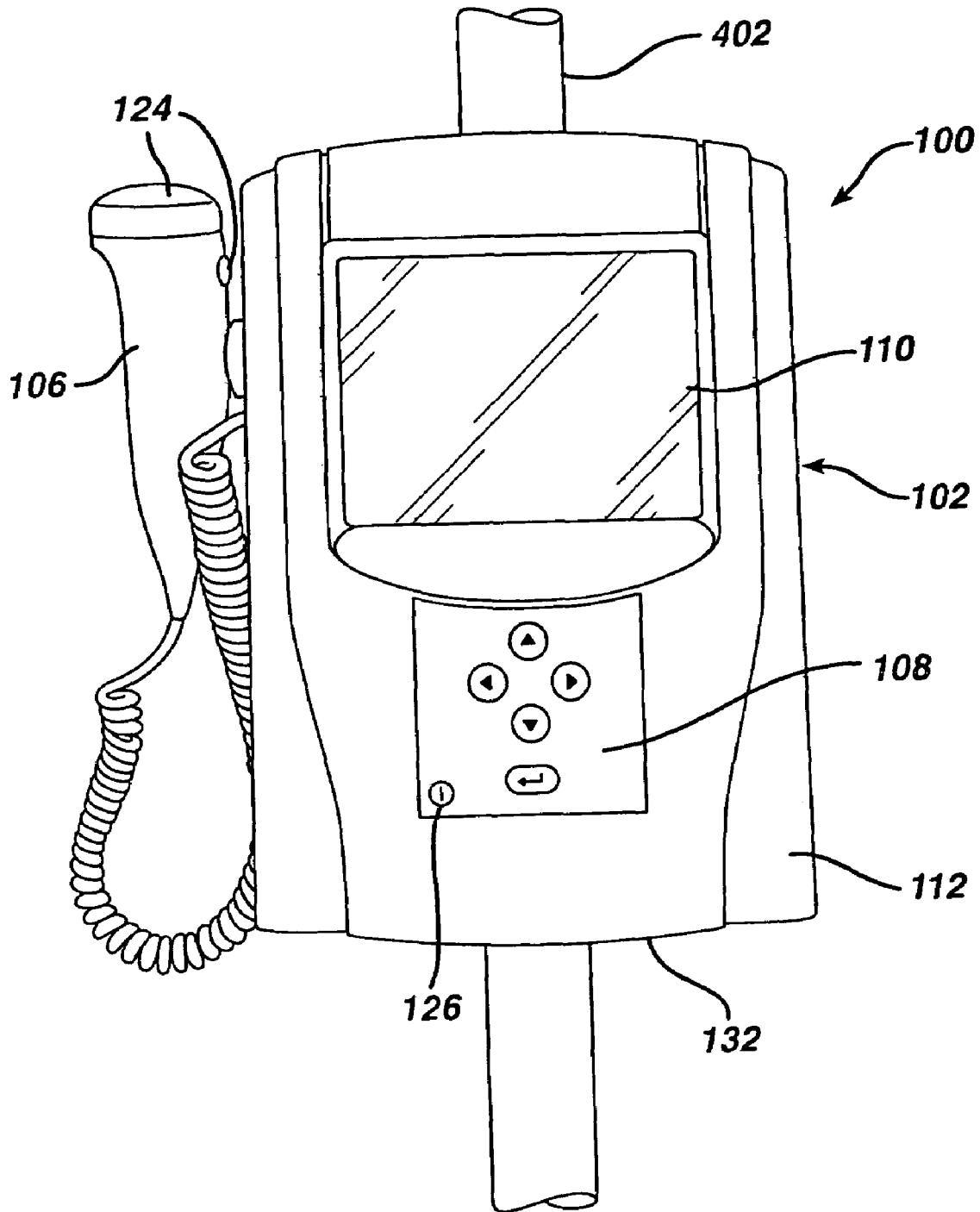
**FIG. 2**



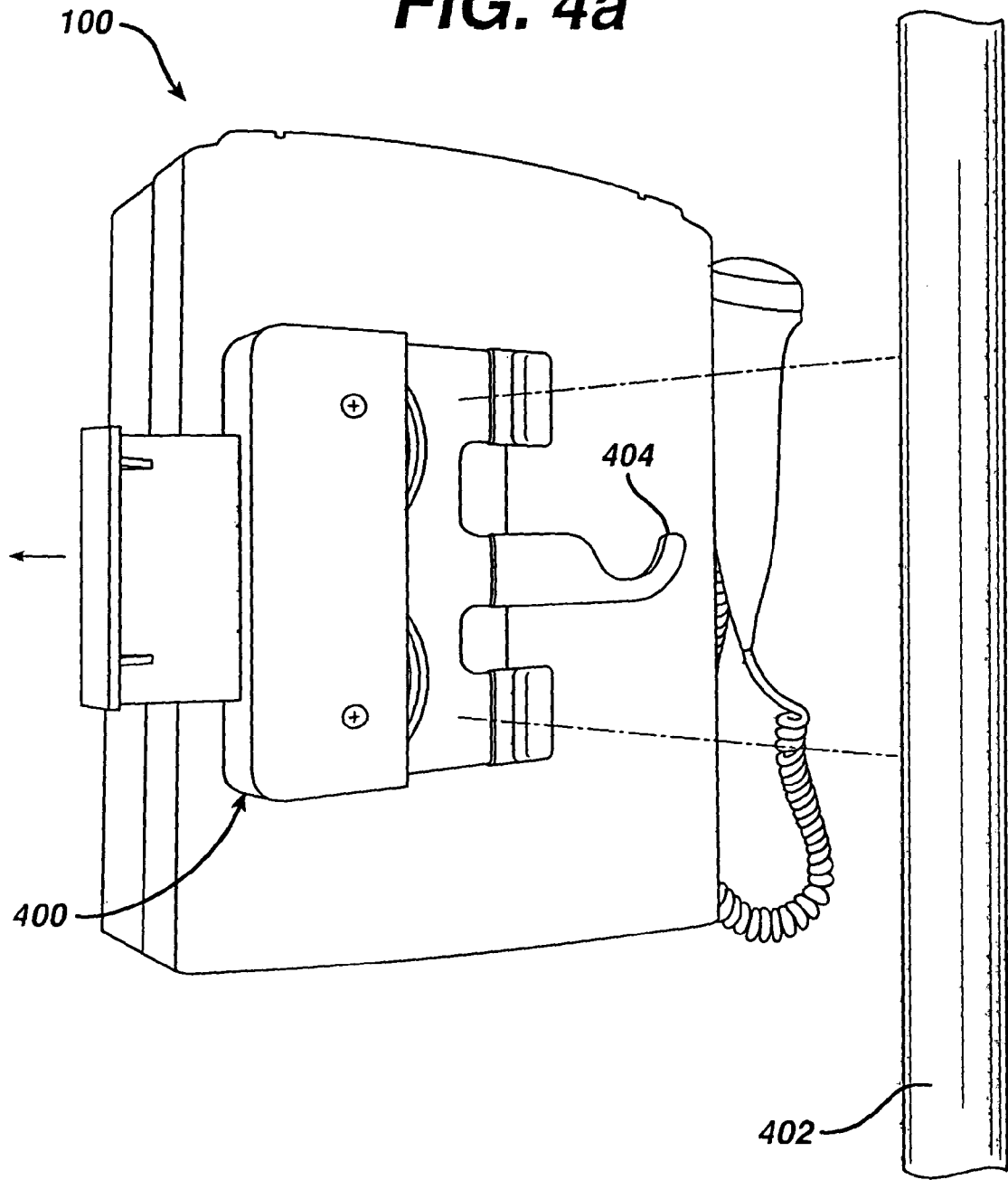
**FIG. 3**



**FIG. 4**

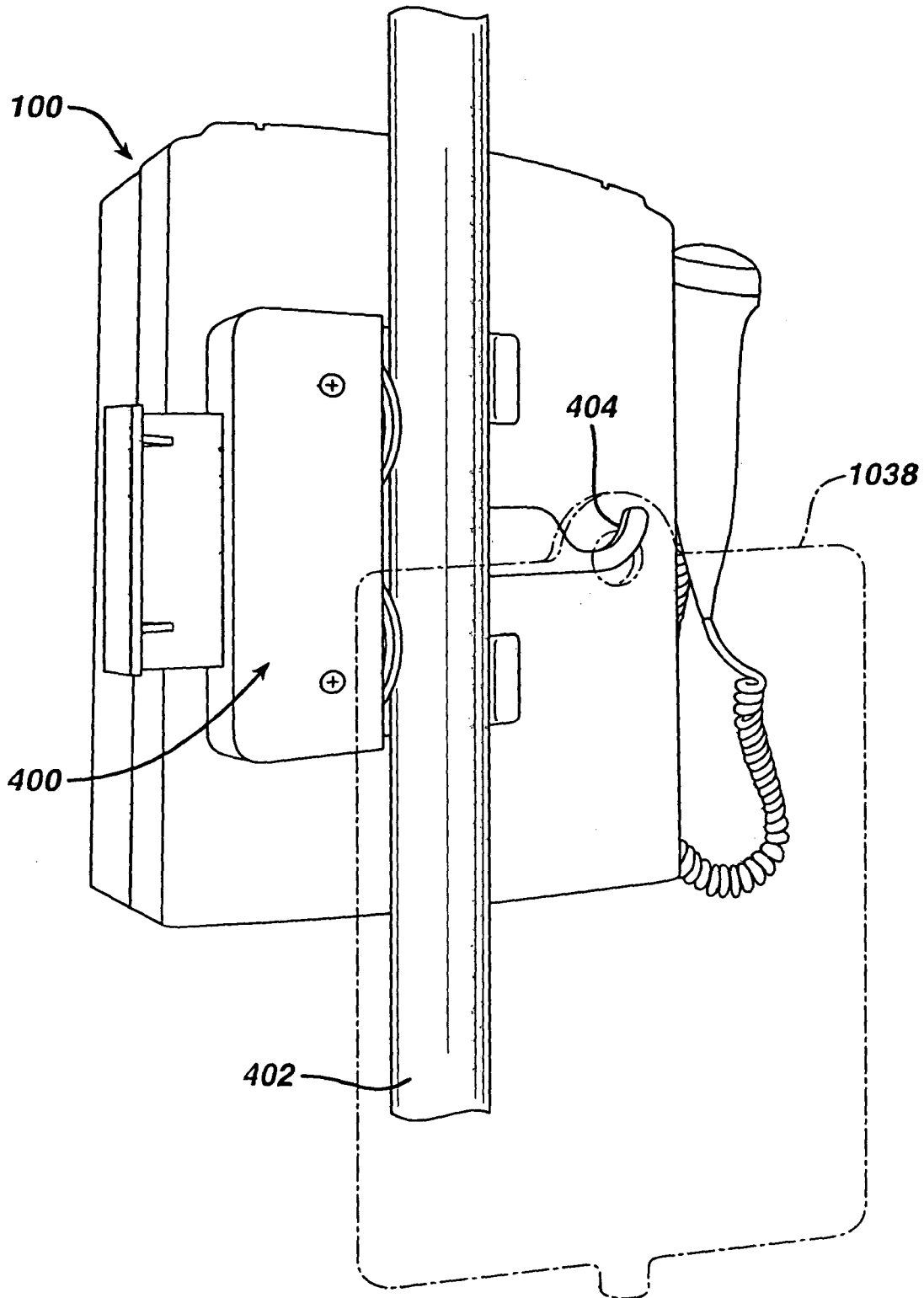


**FIG. 4a**

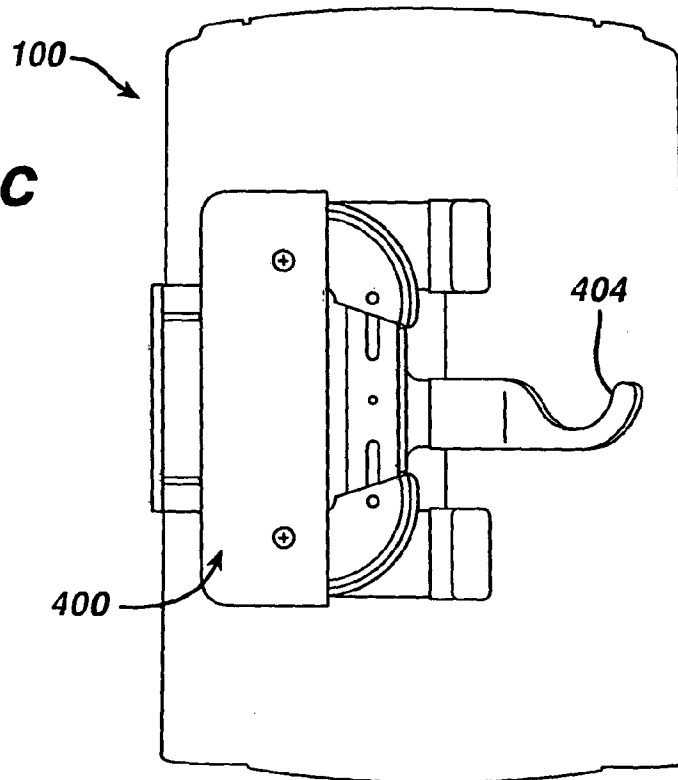




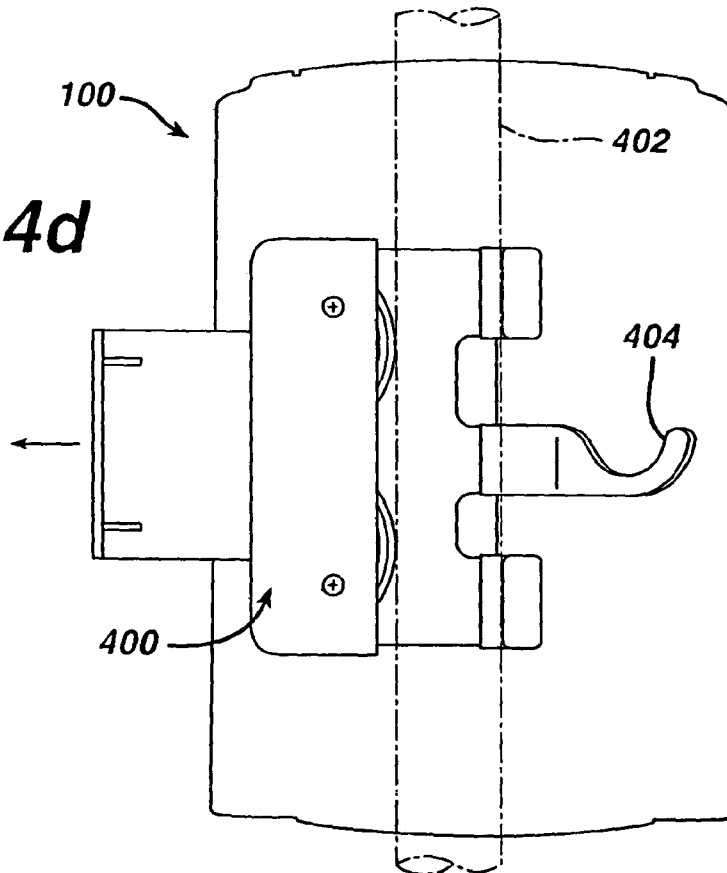
**FIG. 4b**



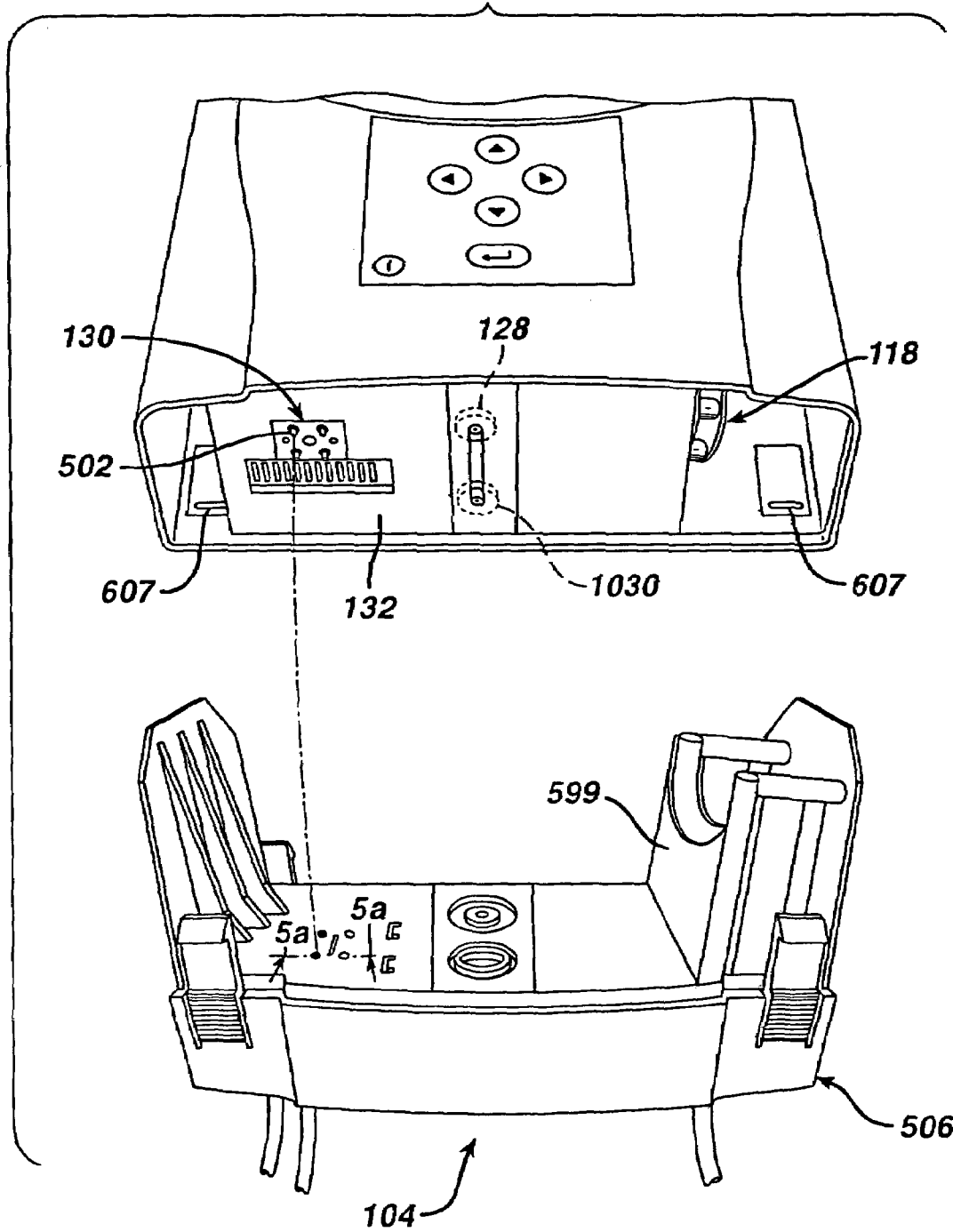
**FIG. 4c**

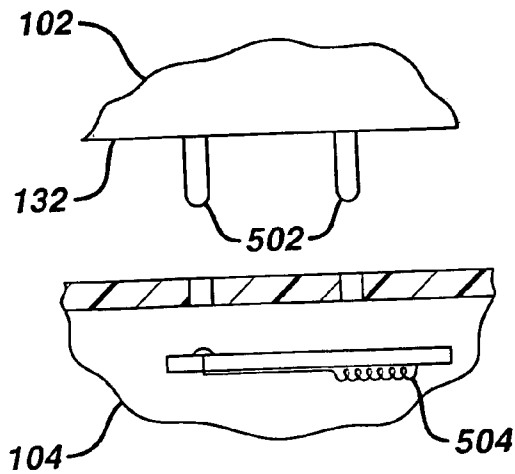


**FIG. 4d**

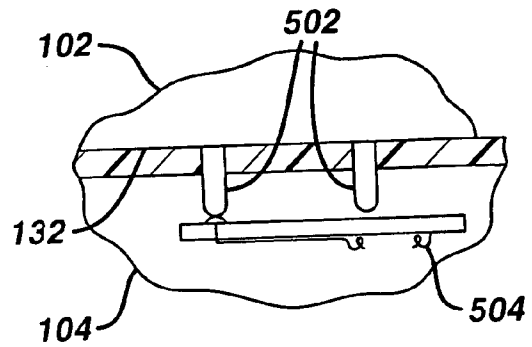


**FIG. 5**





**FIG. 5a**



**FIG. 5b**

**FIG. 6**

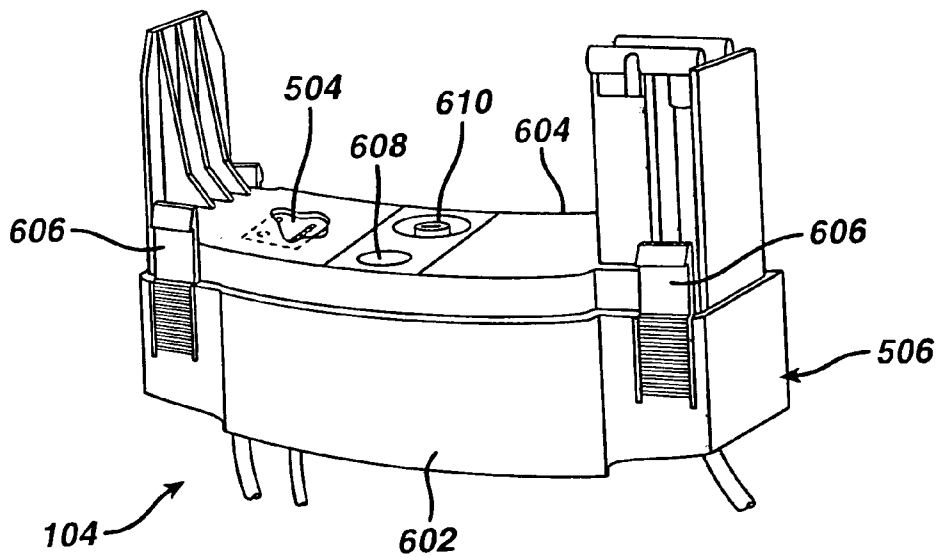
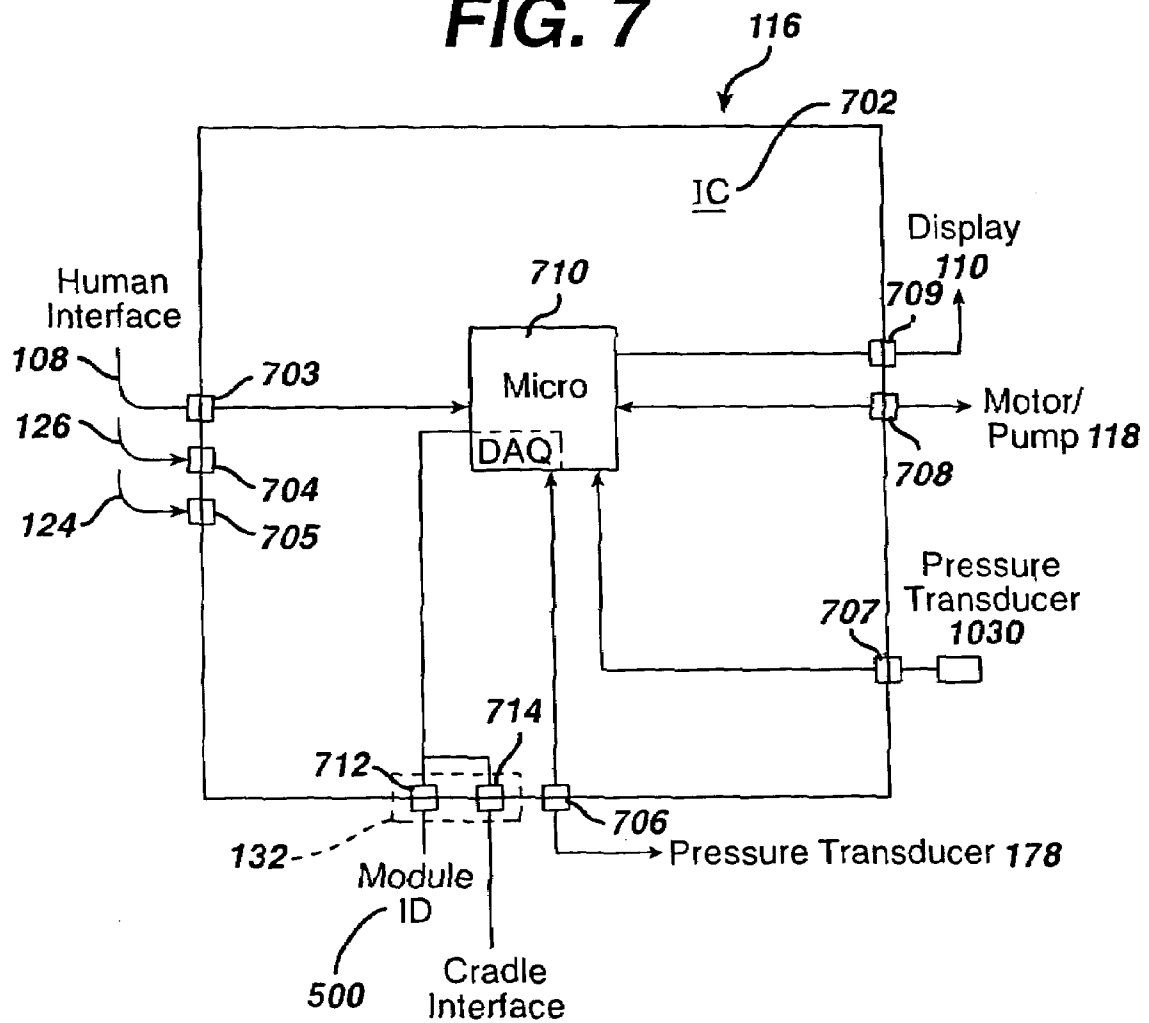
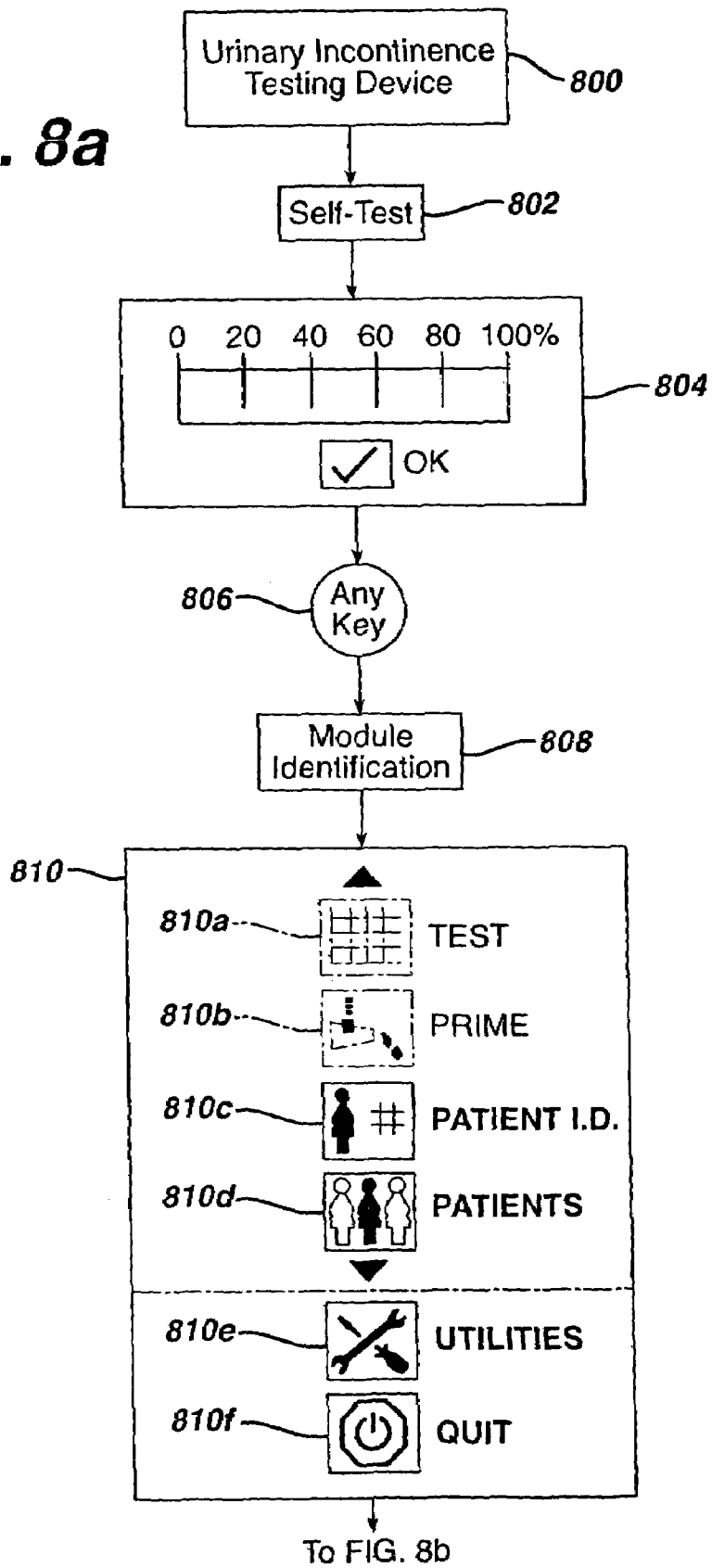


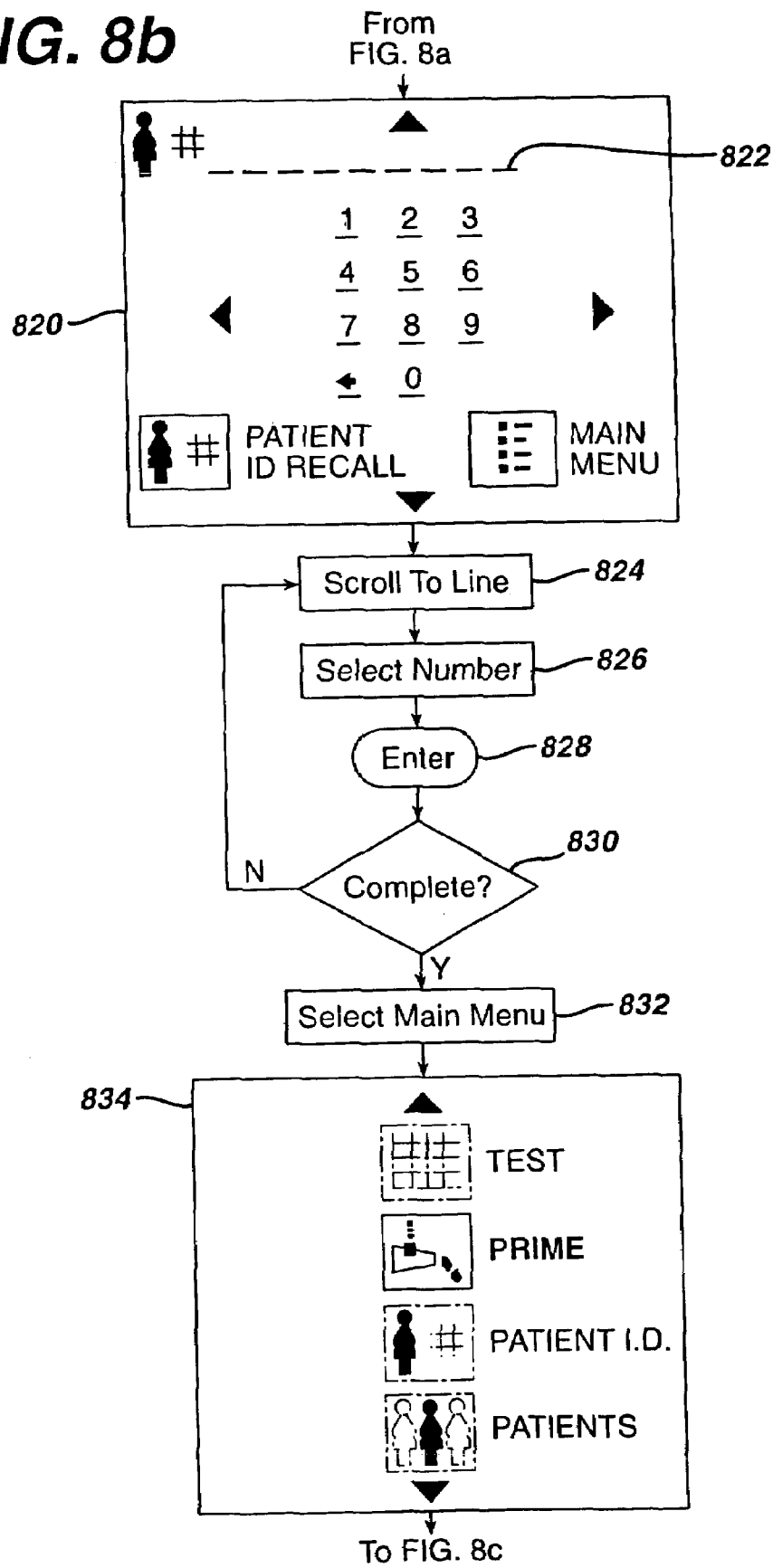
FIG. 7



**FIG. 8a**



**FIG. 8b**



**FIG. 8c**

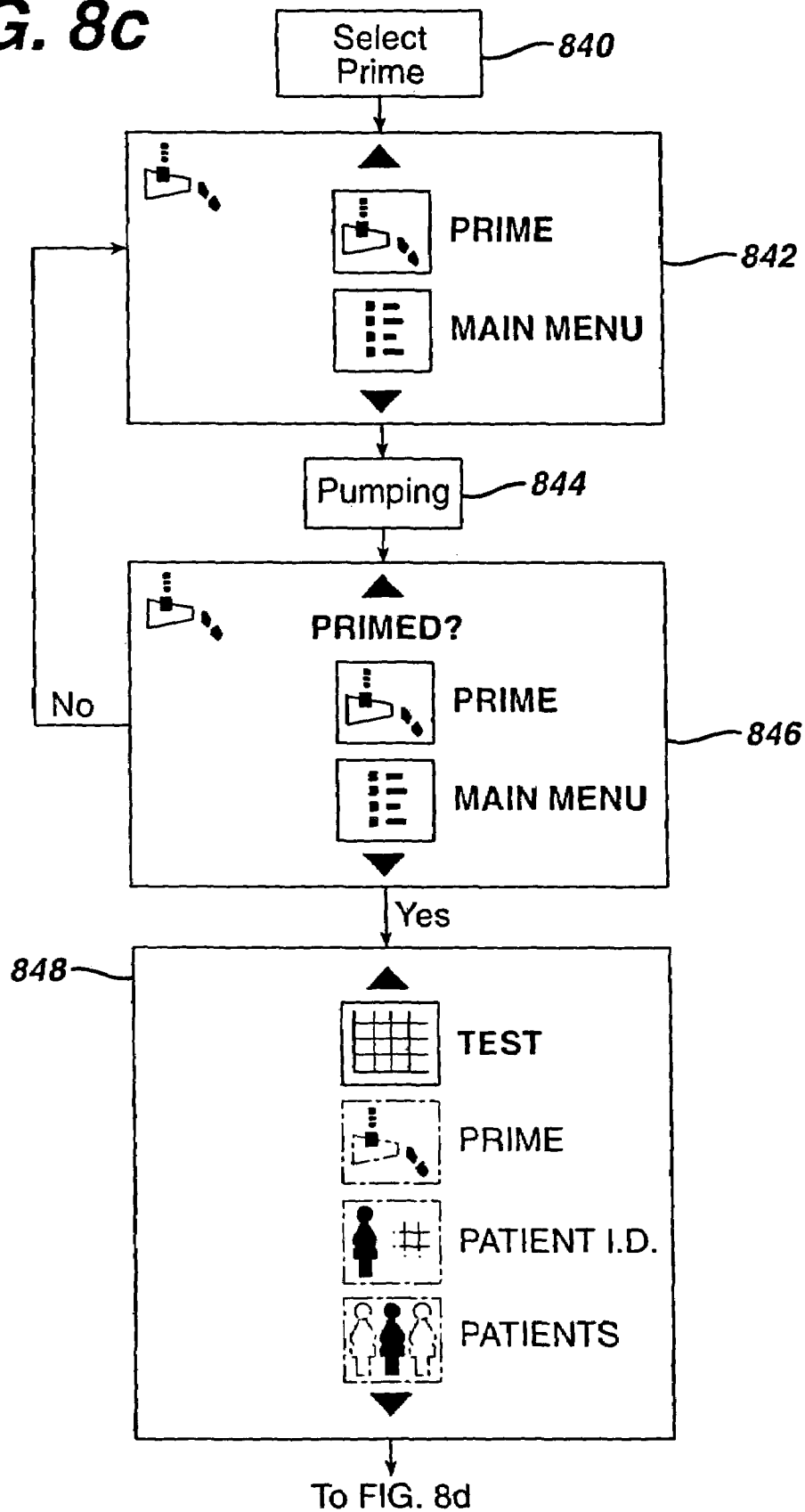
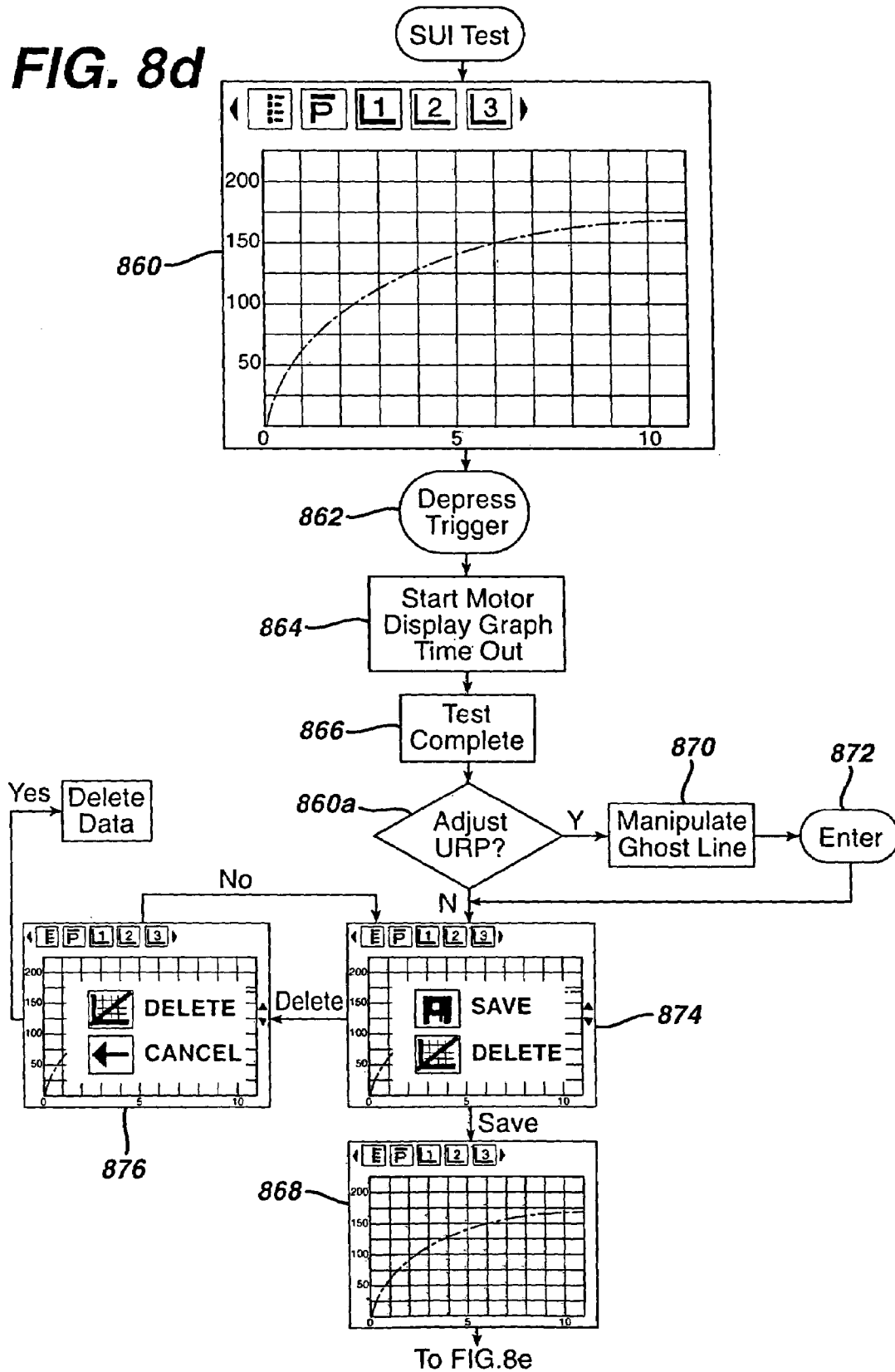
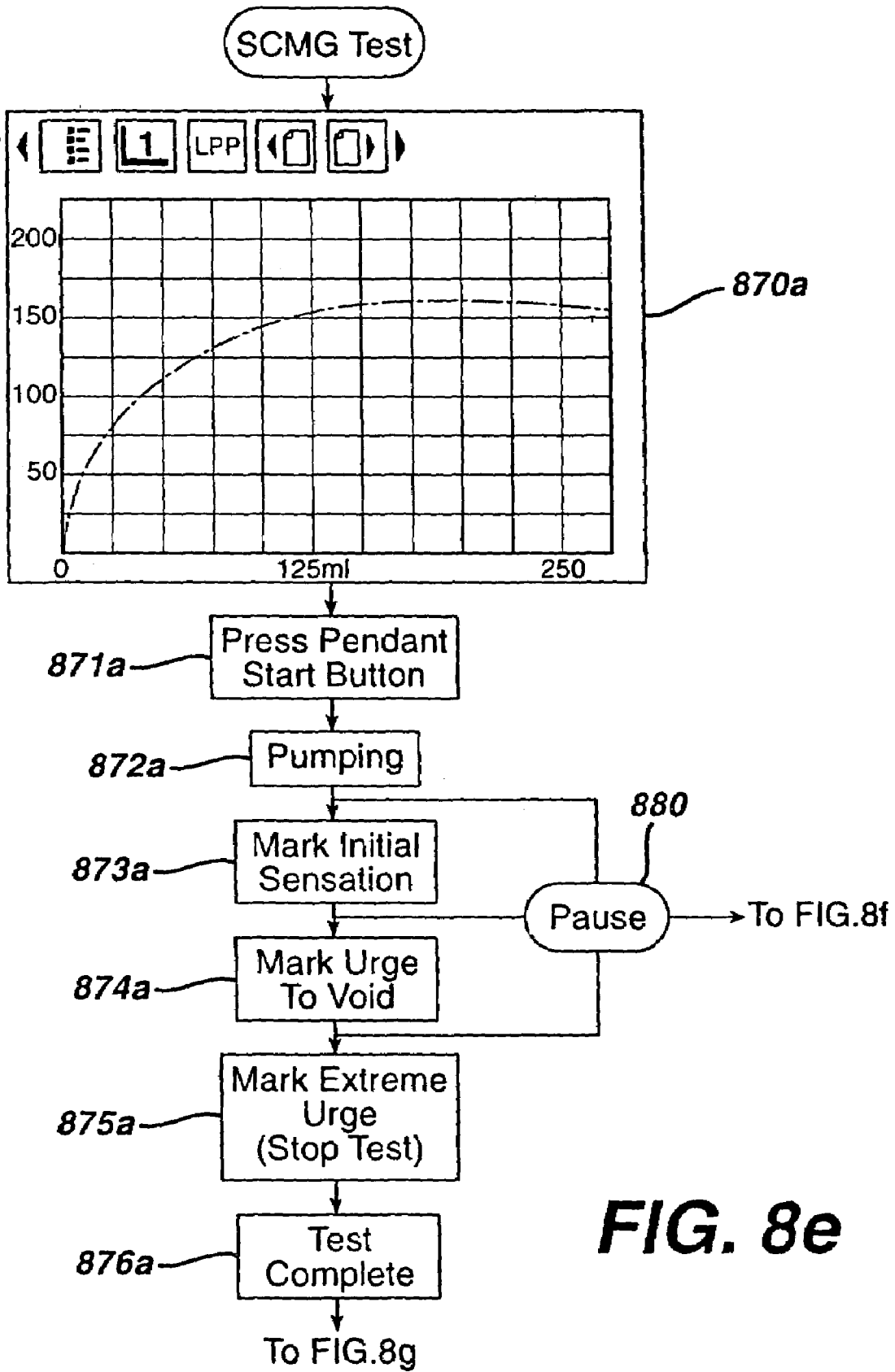




FIG. 8d





**FIG. 8e**

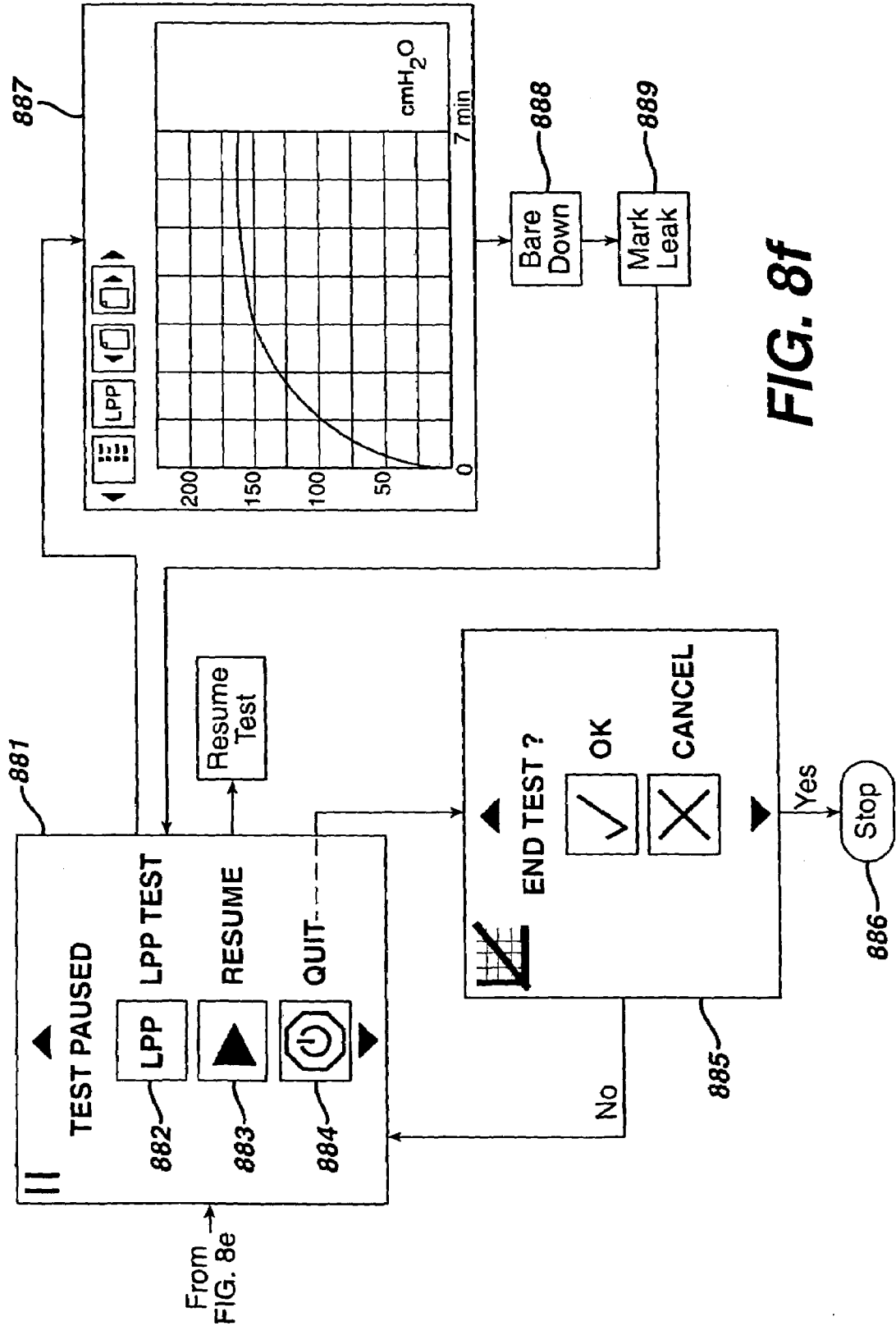
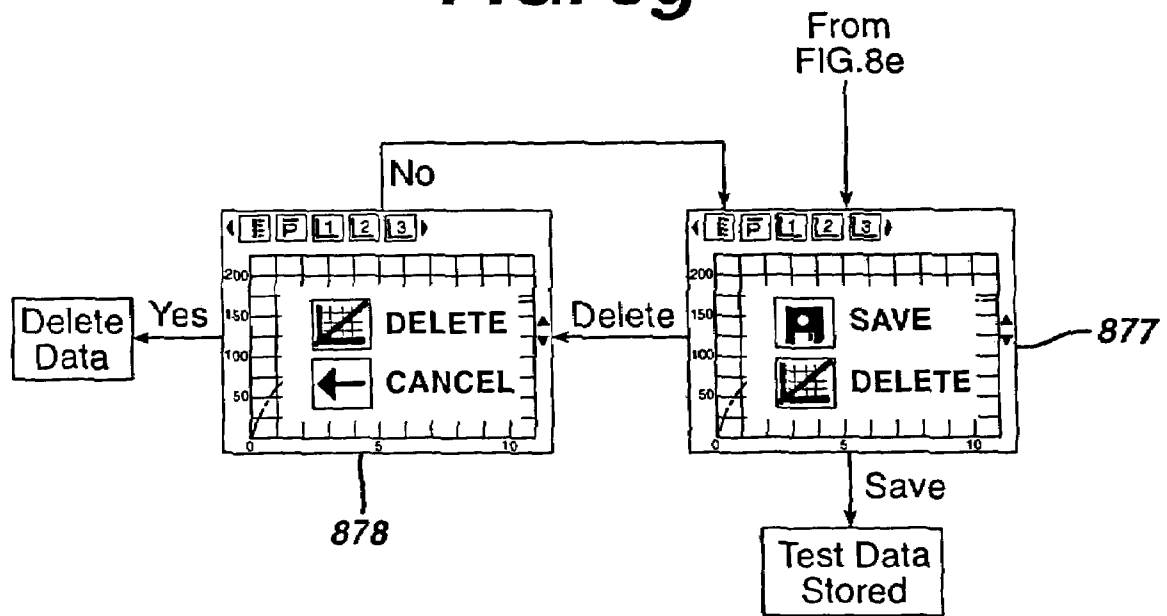


FIG. 8f

**FIG. 8g**



# FIG. 8h

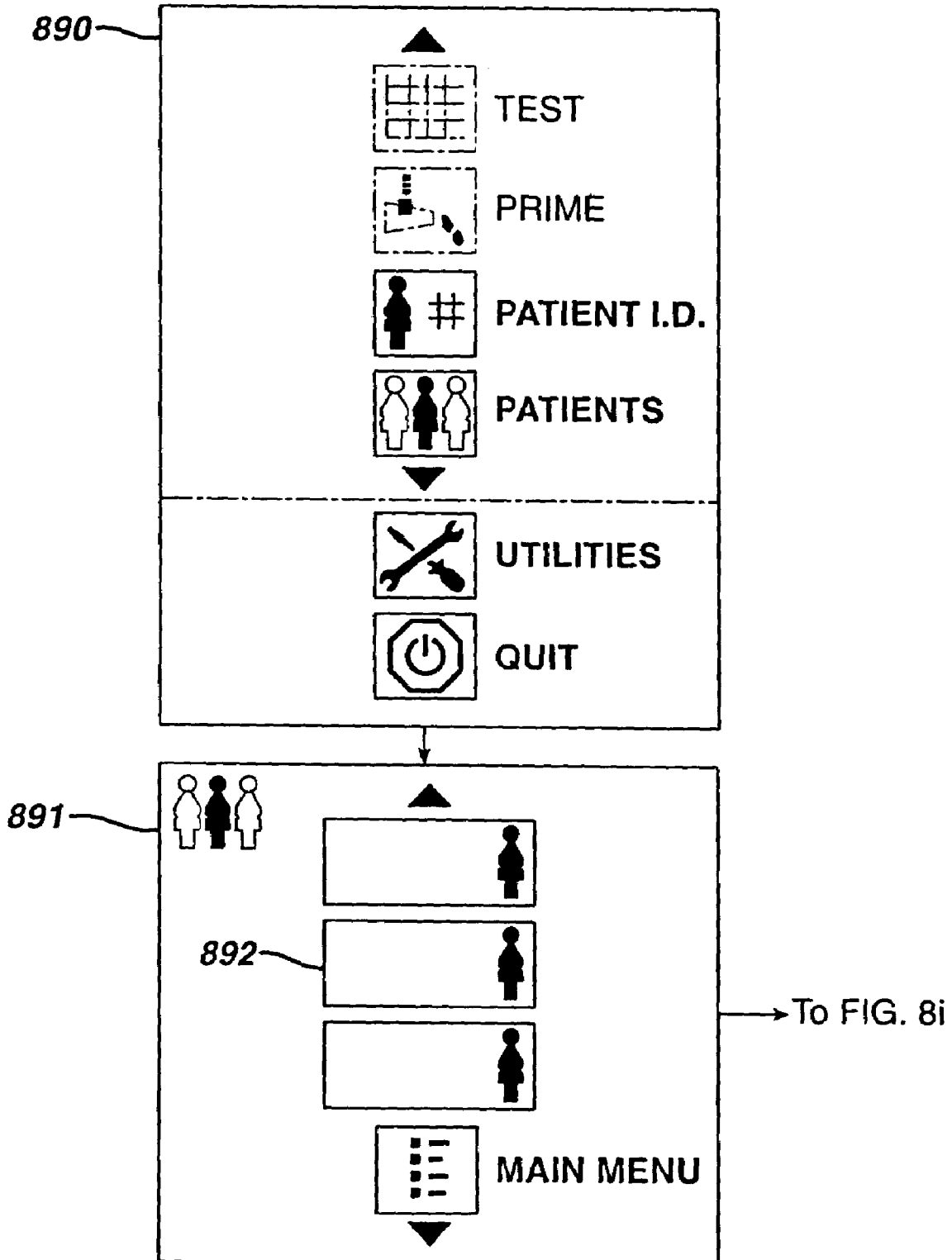
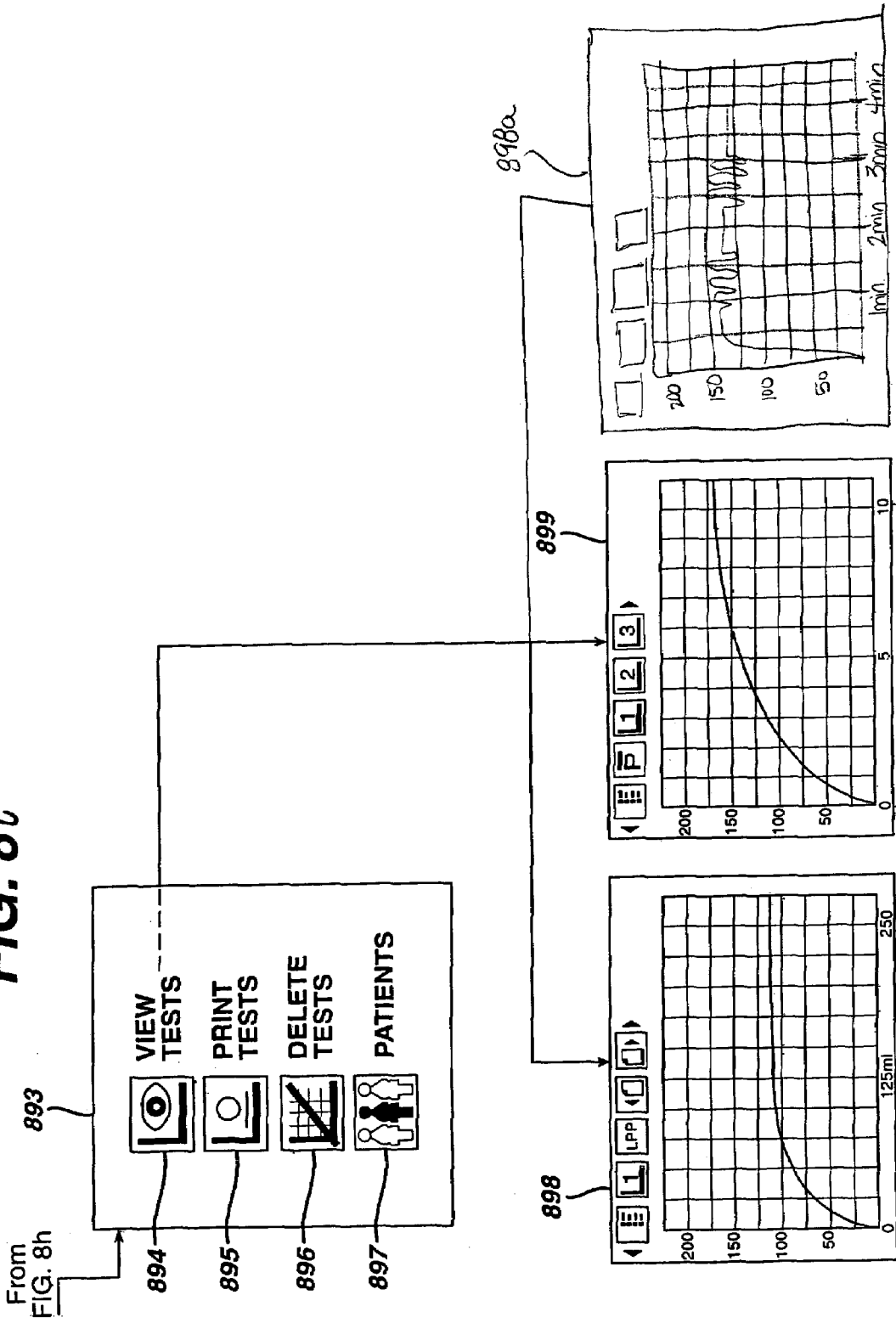
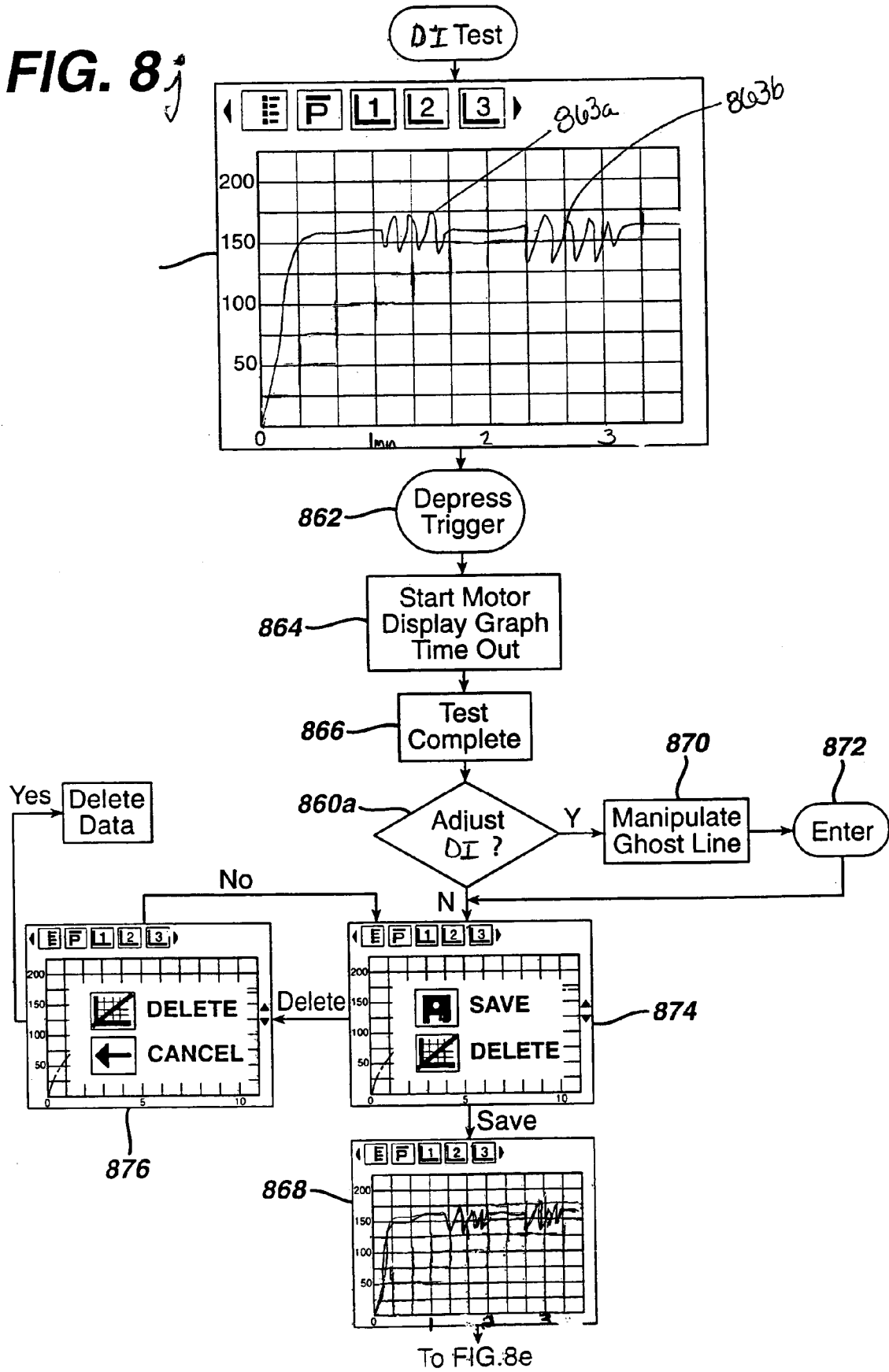


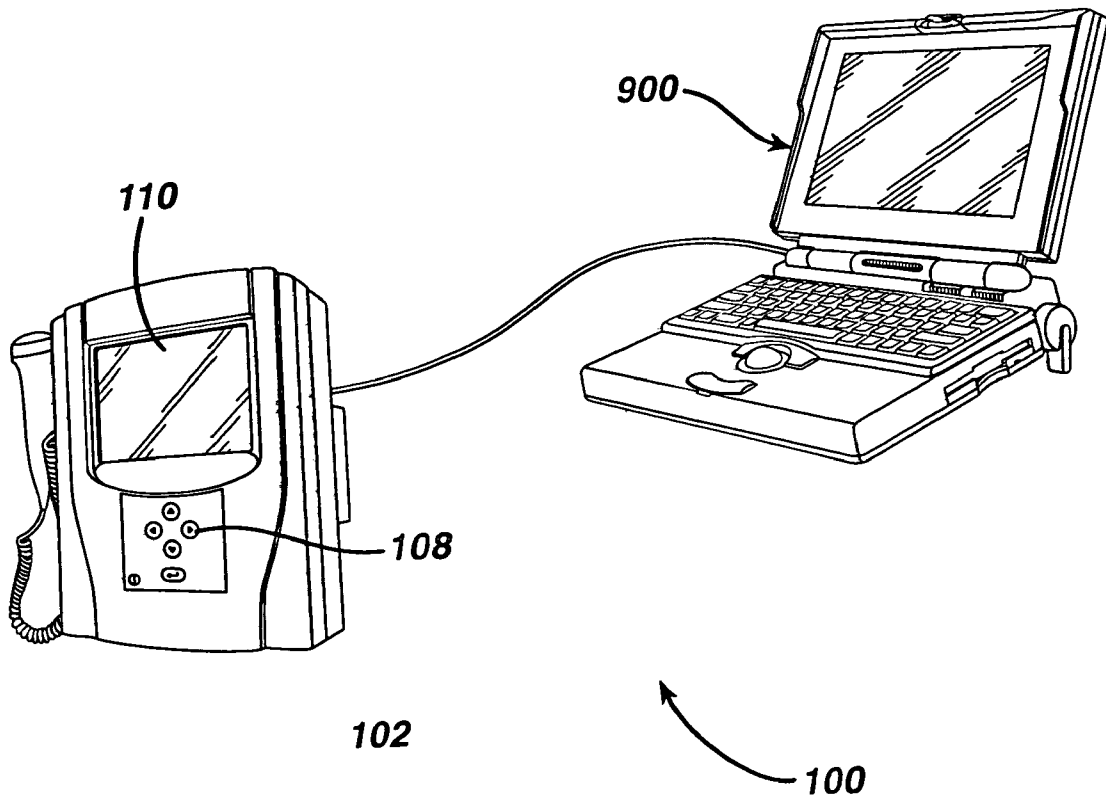
FIG. 8i



**FIG. 8j**

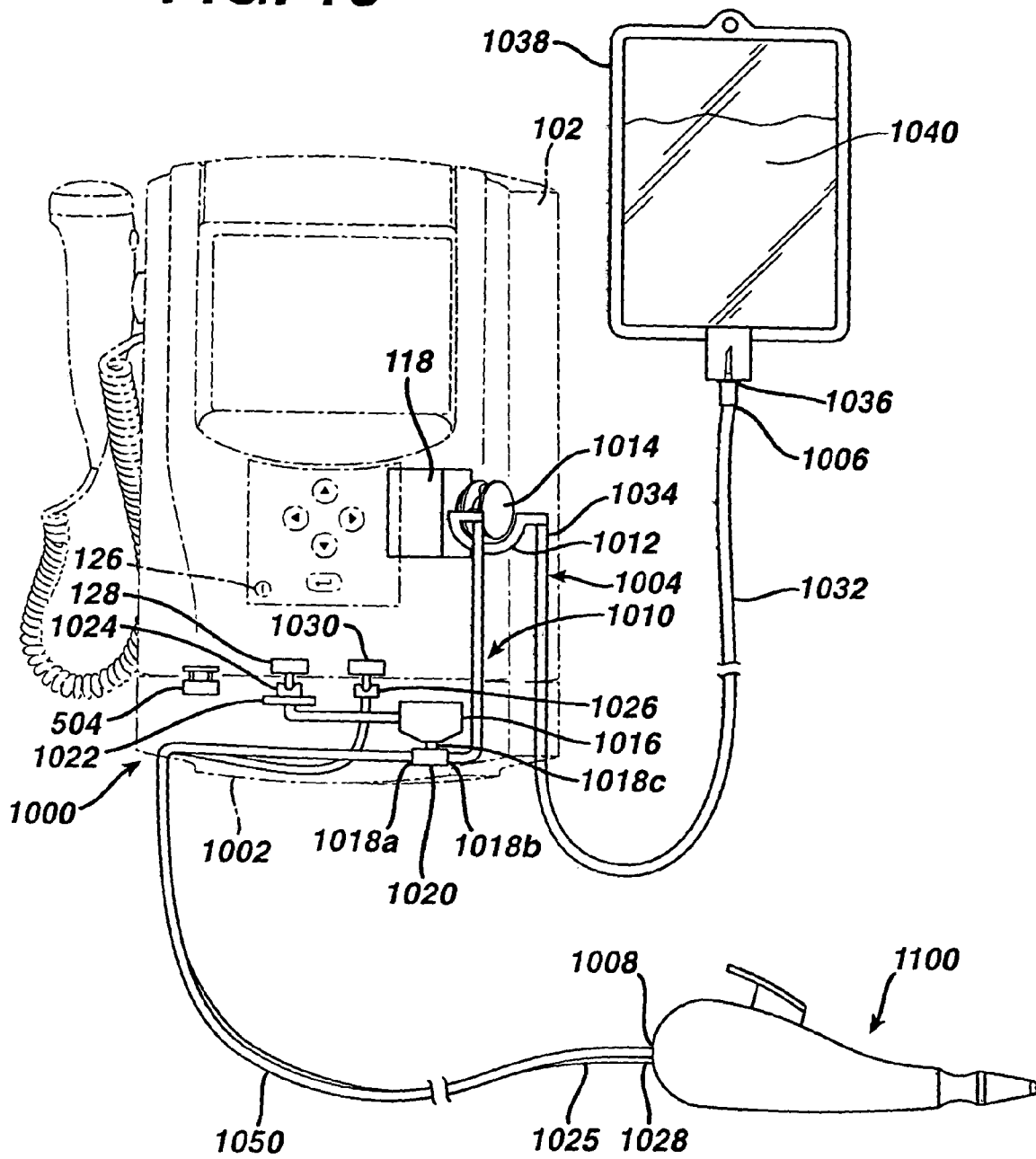


**FIG. 9**

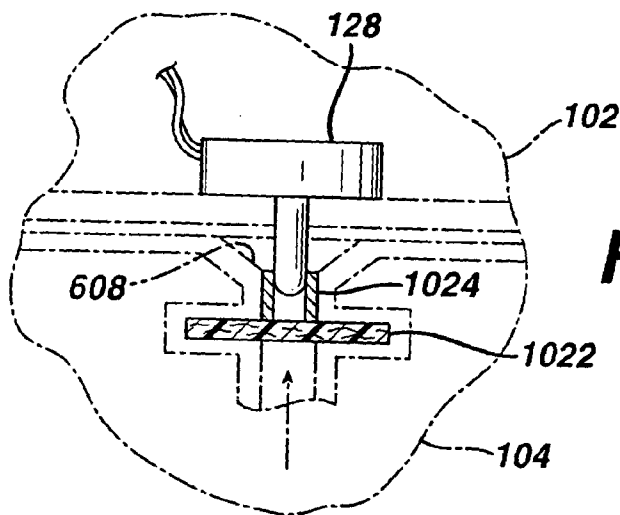
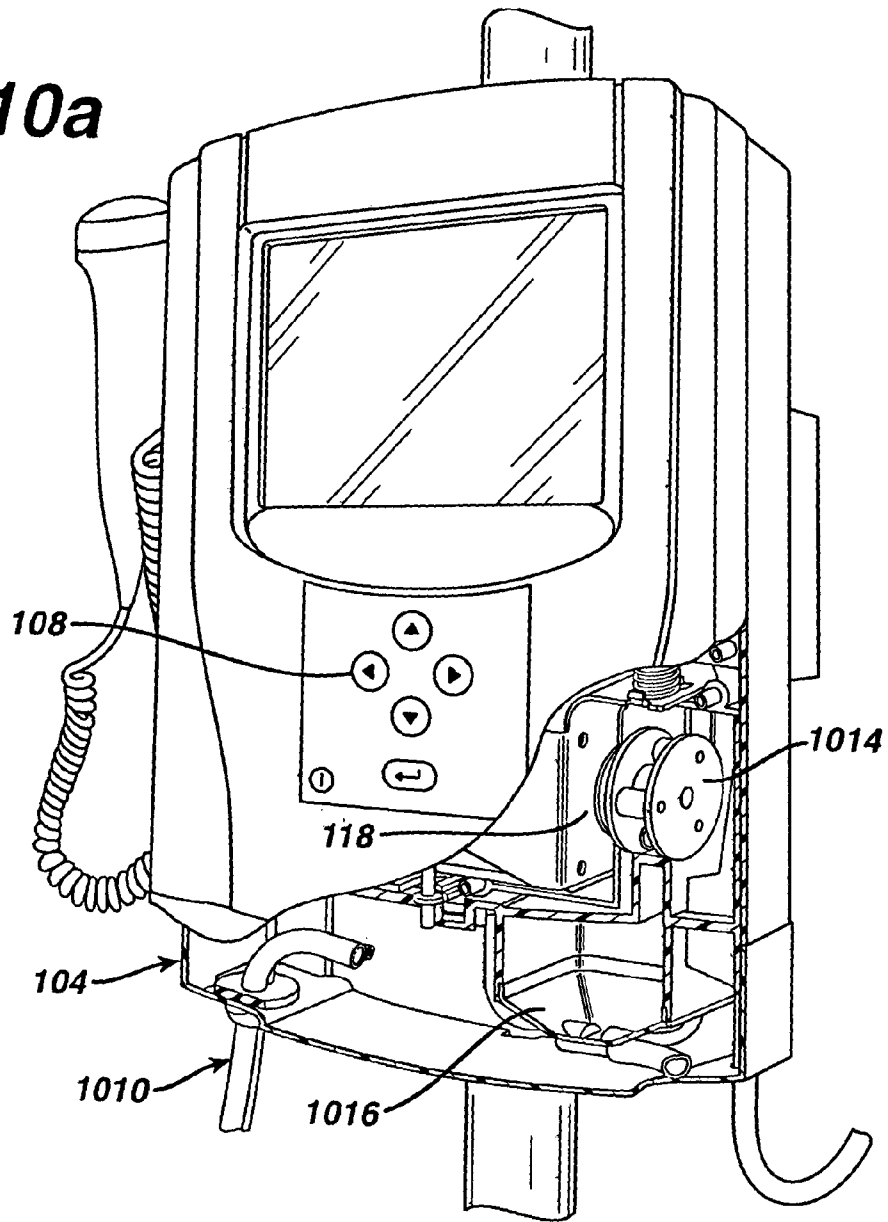




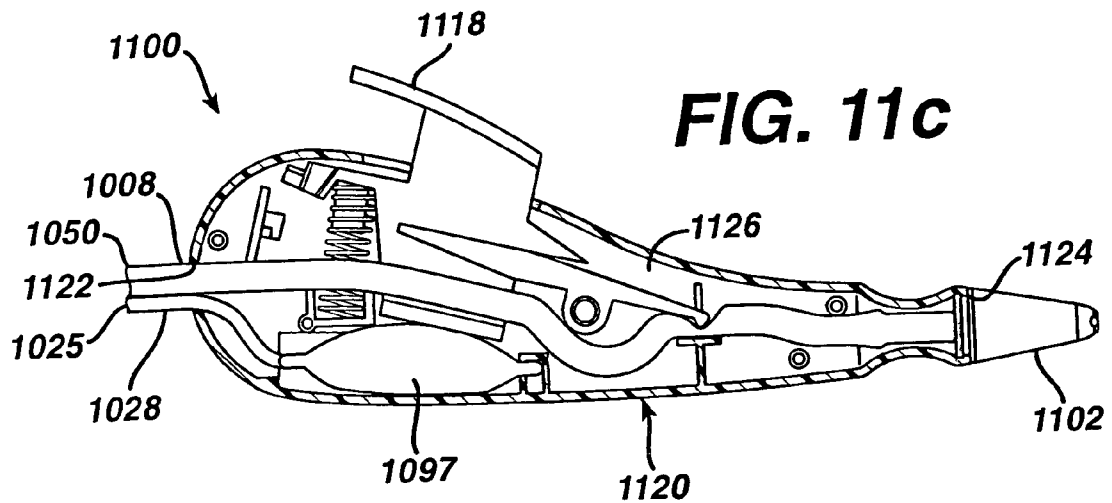
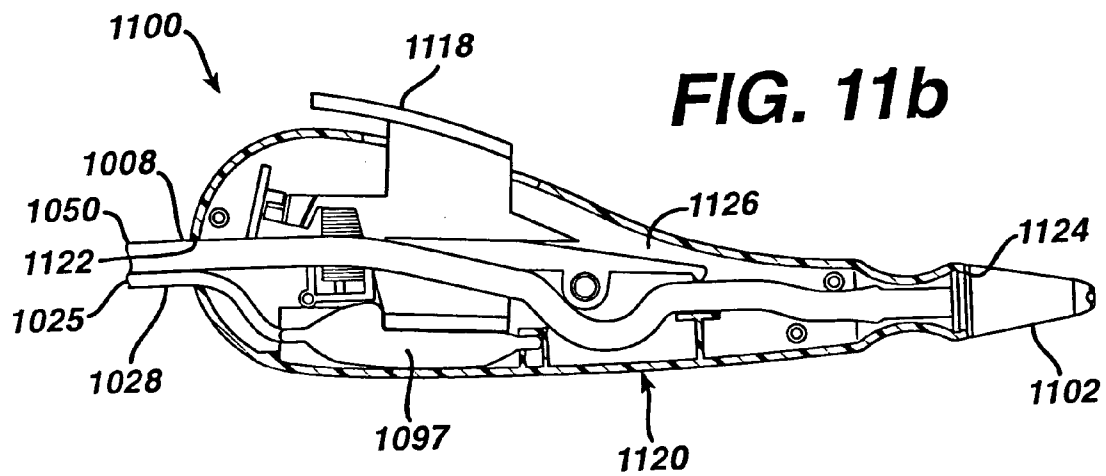
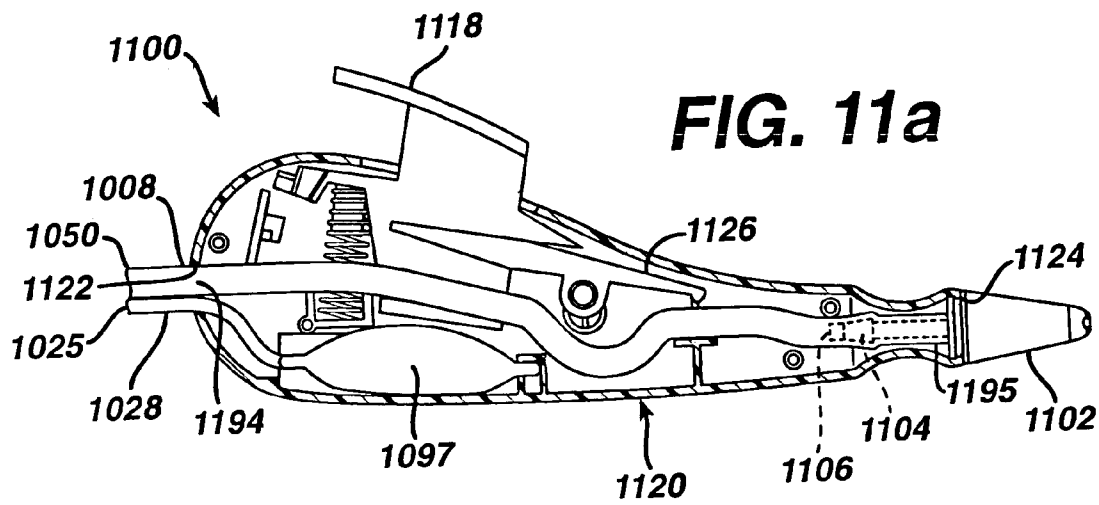
**FIG. 10**

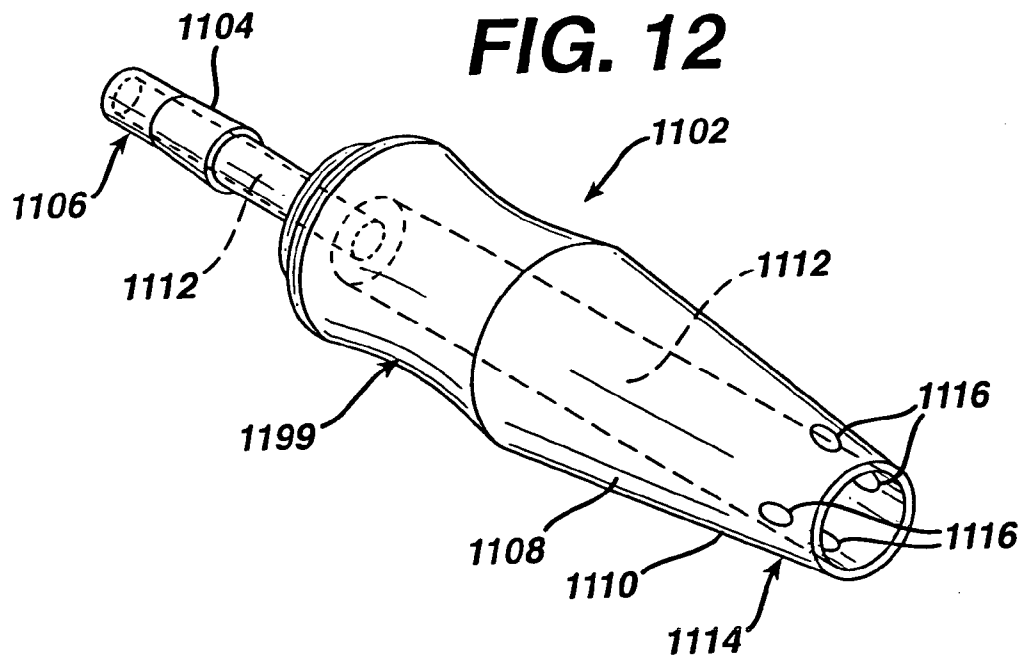
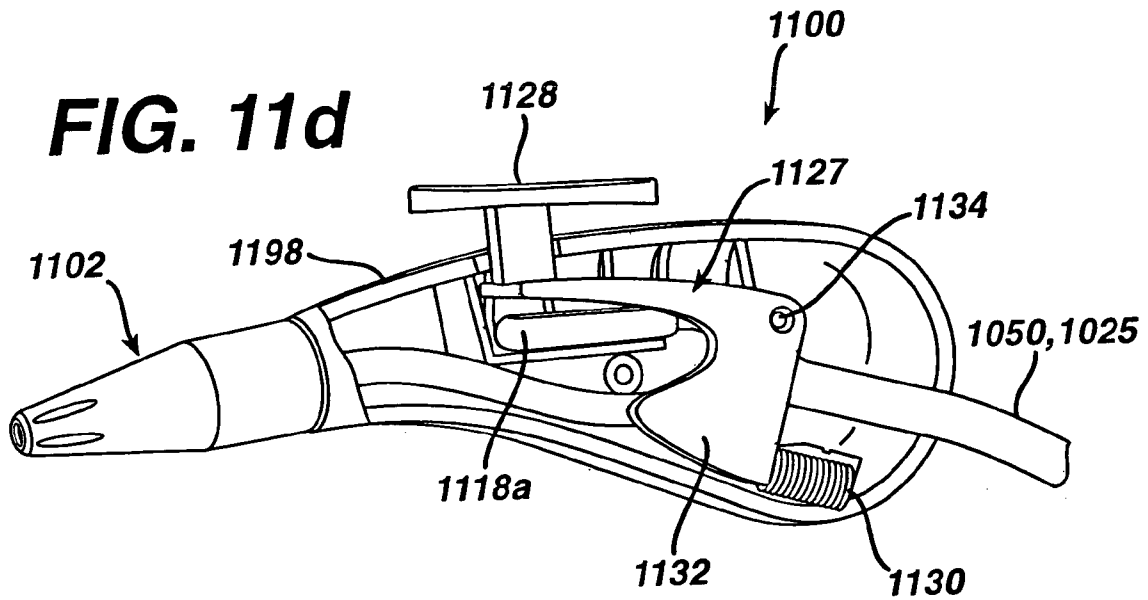


**FIG. 10a**



**FIG. 10b**





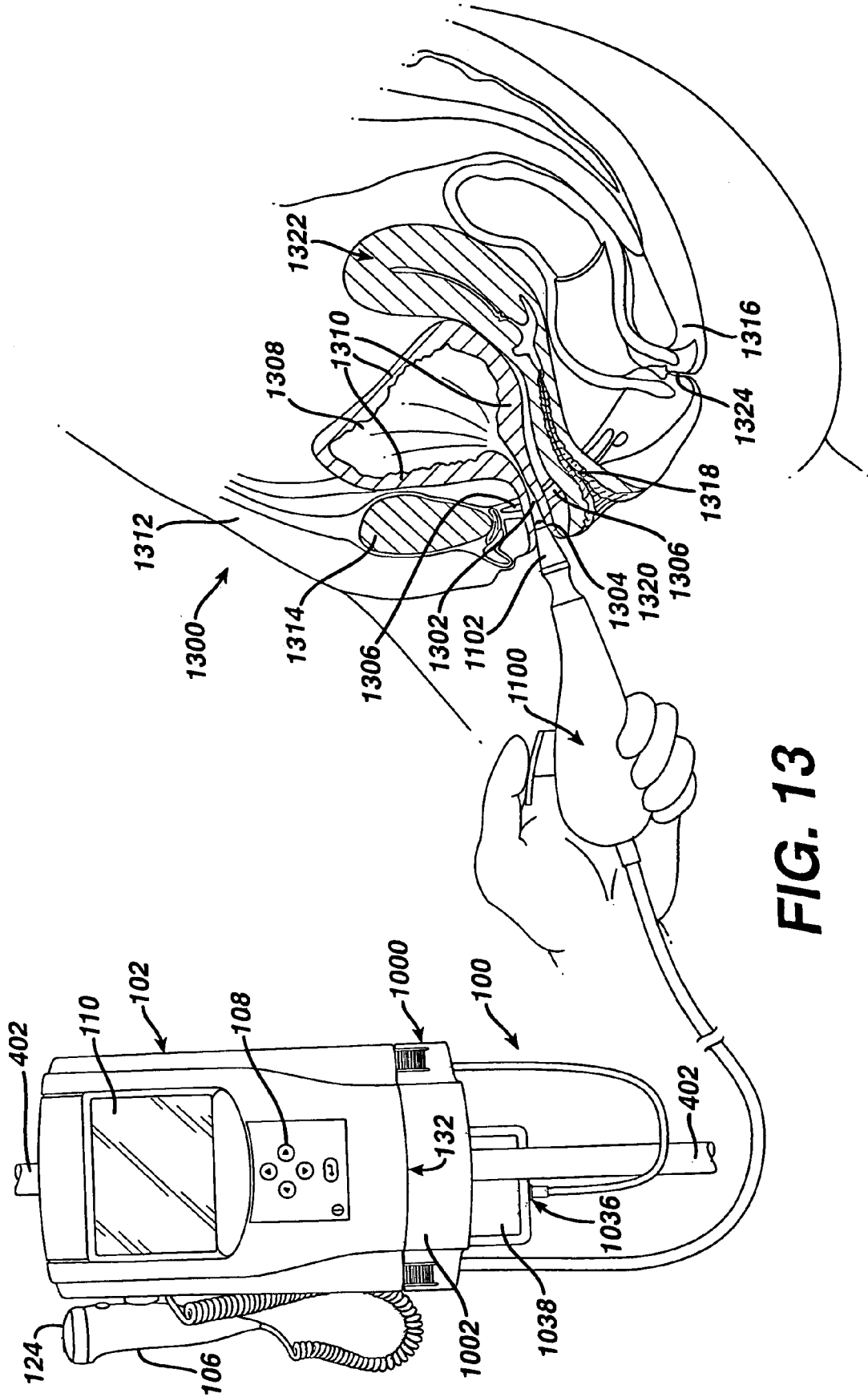
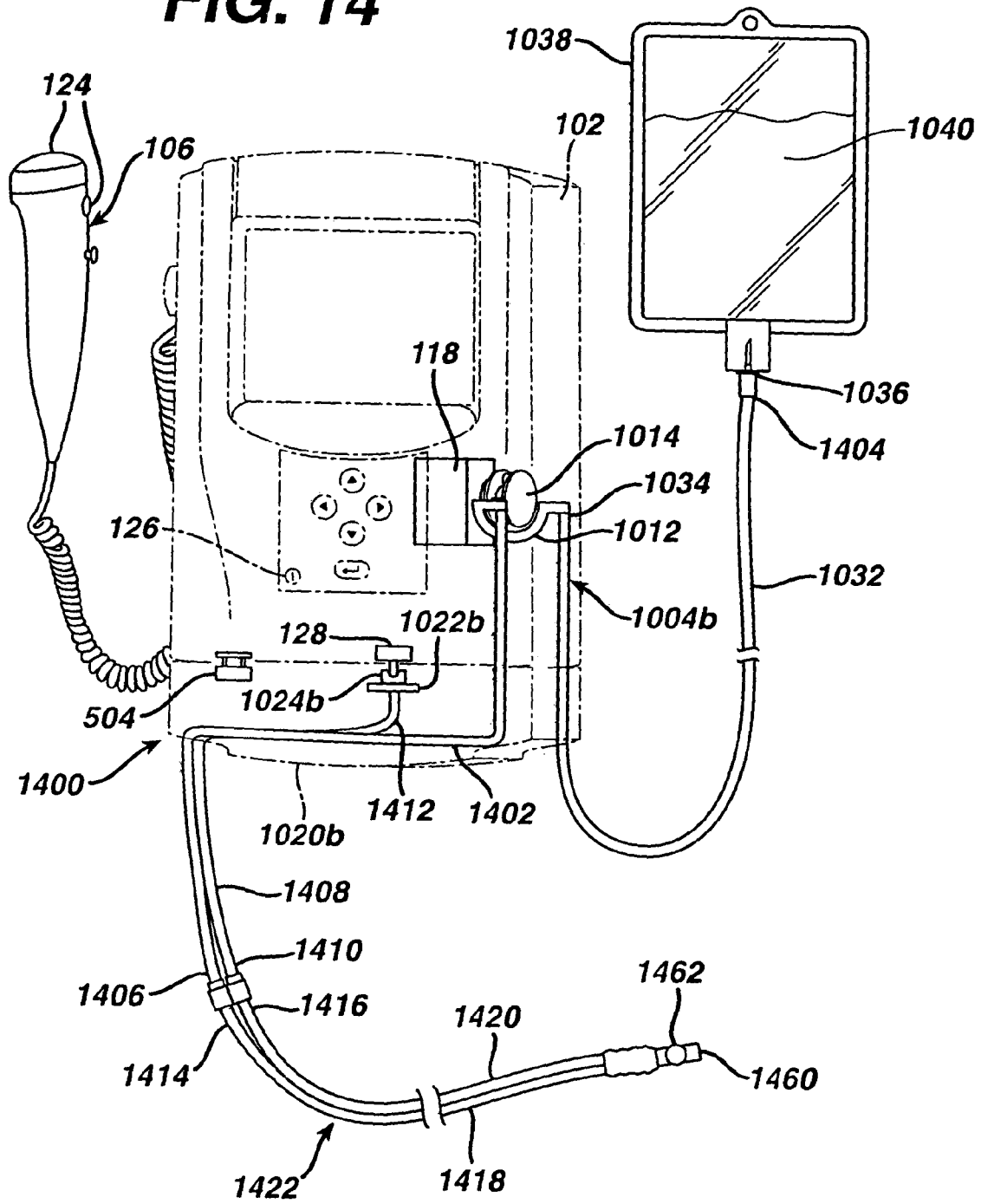
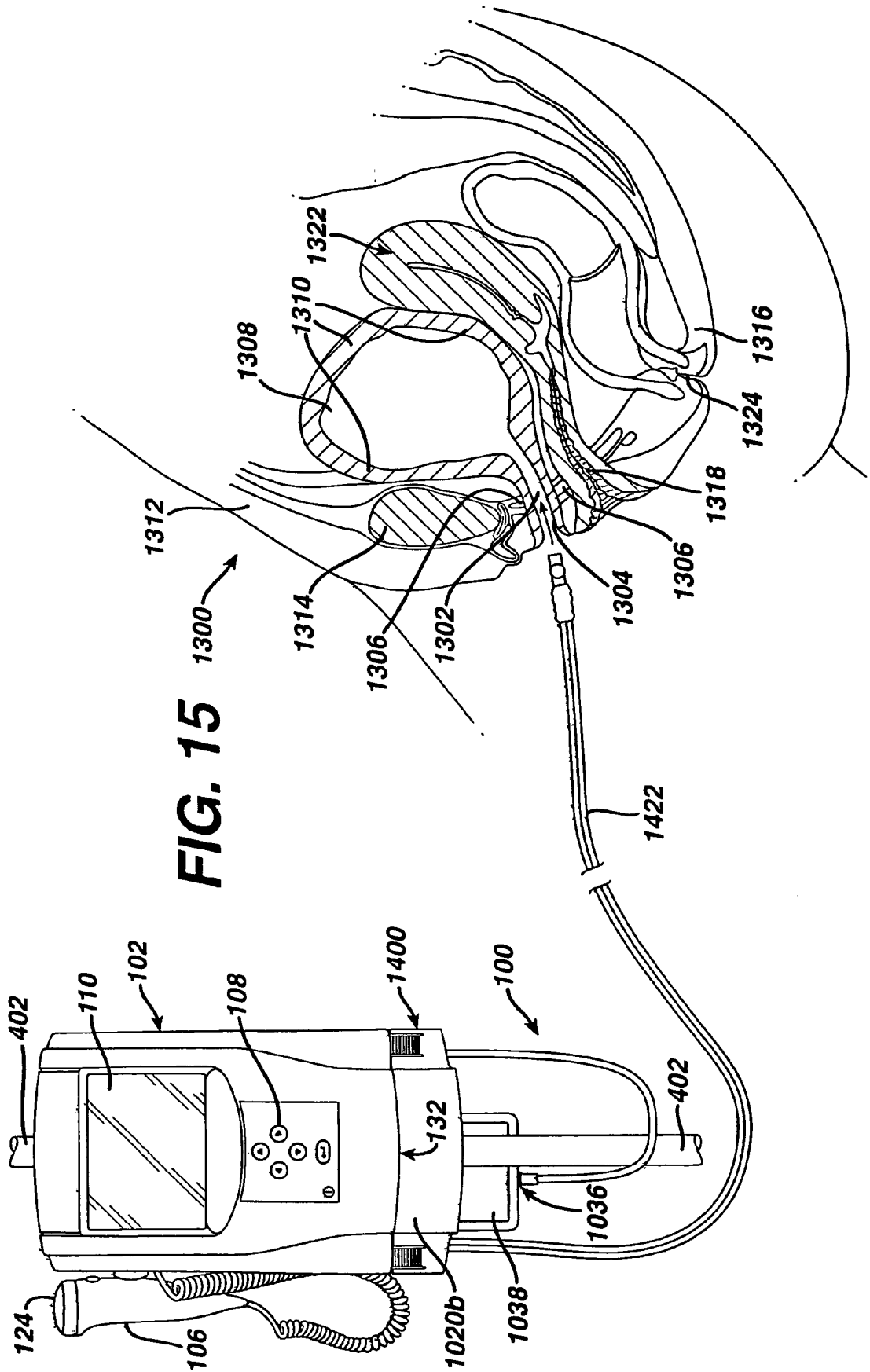


FIG. 13

**FIG. 14**





**FIG. 15**

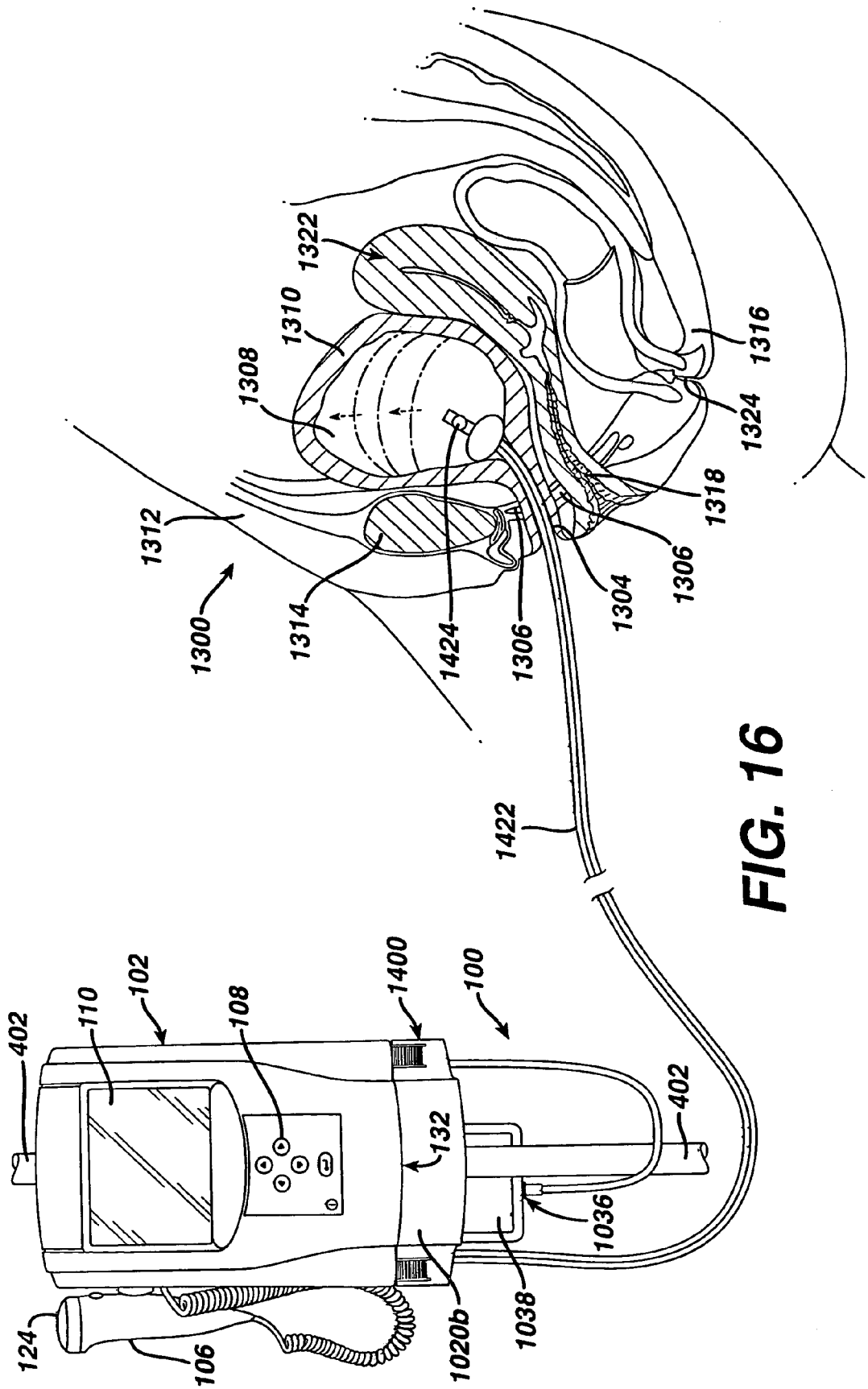
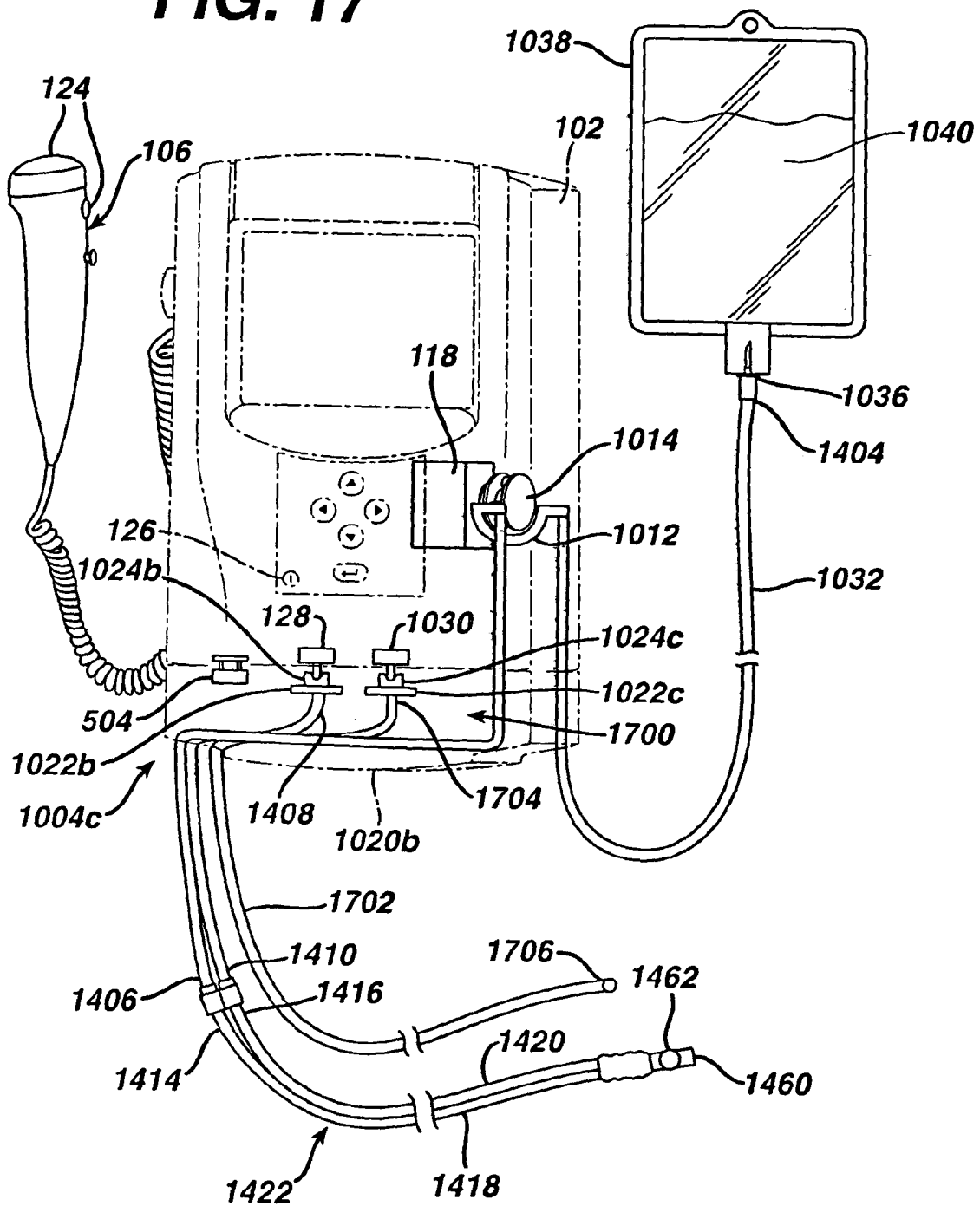


FIG. 16



**FIG. 17**



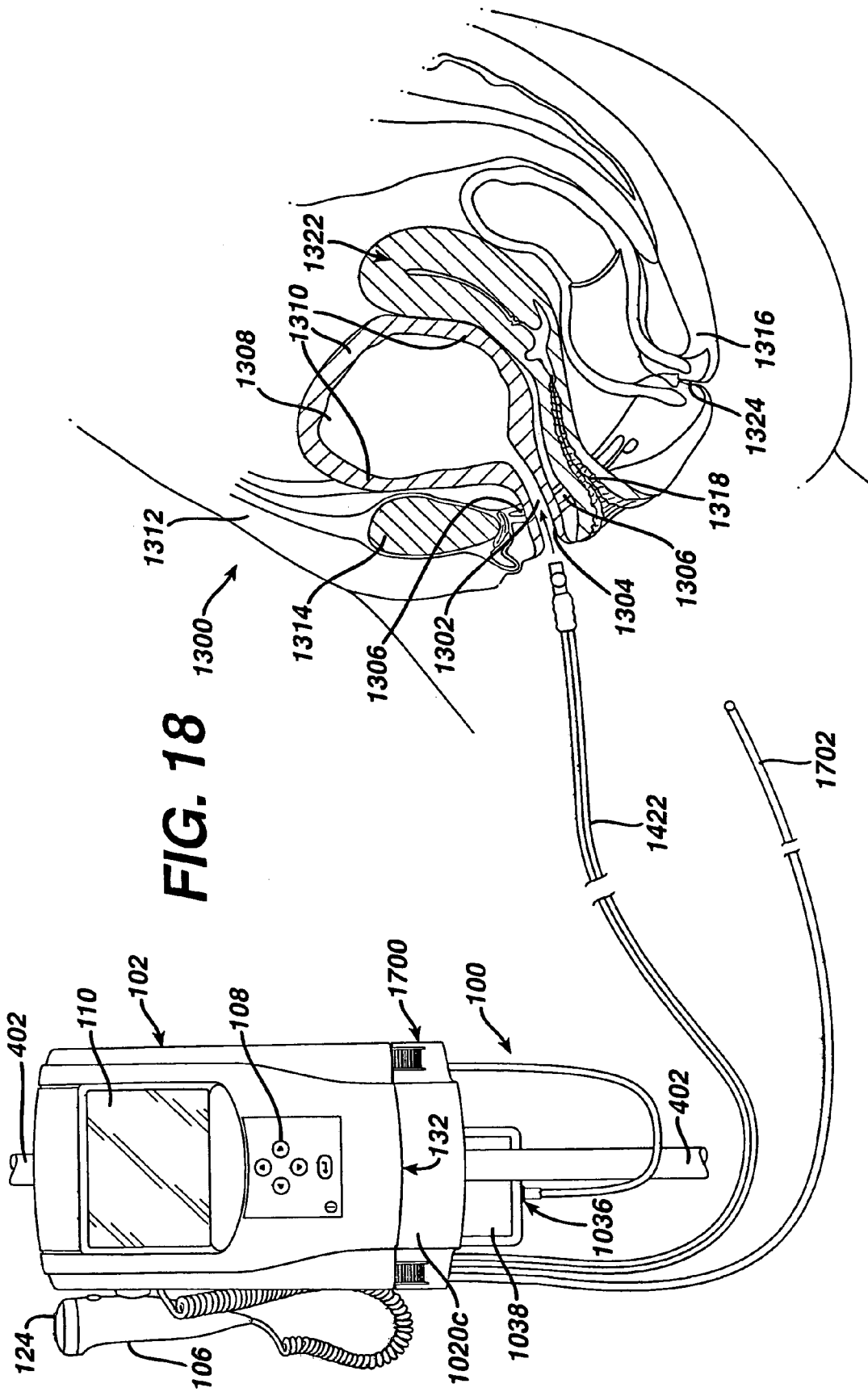


FIG. 18

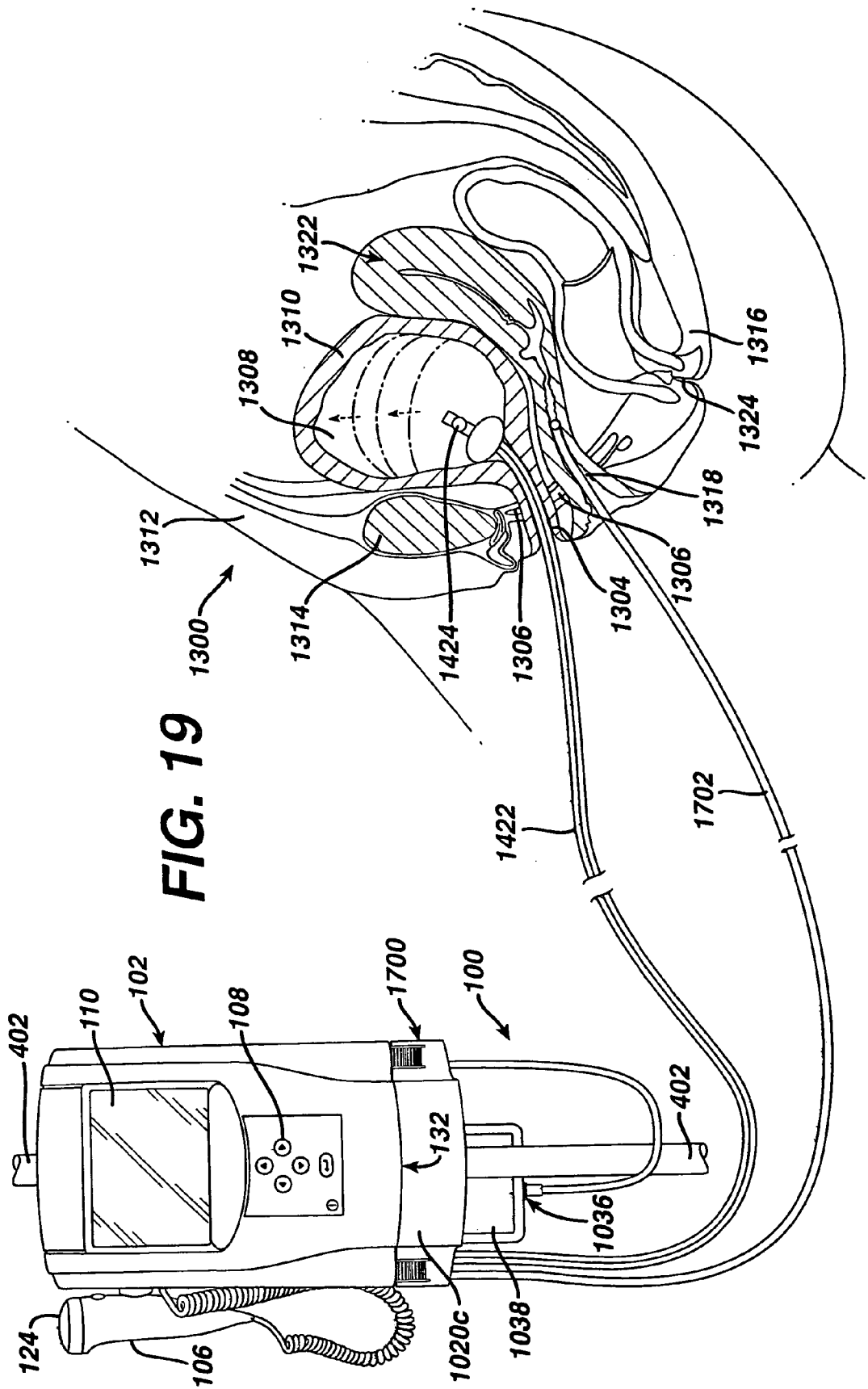
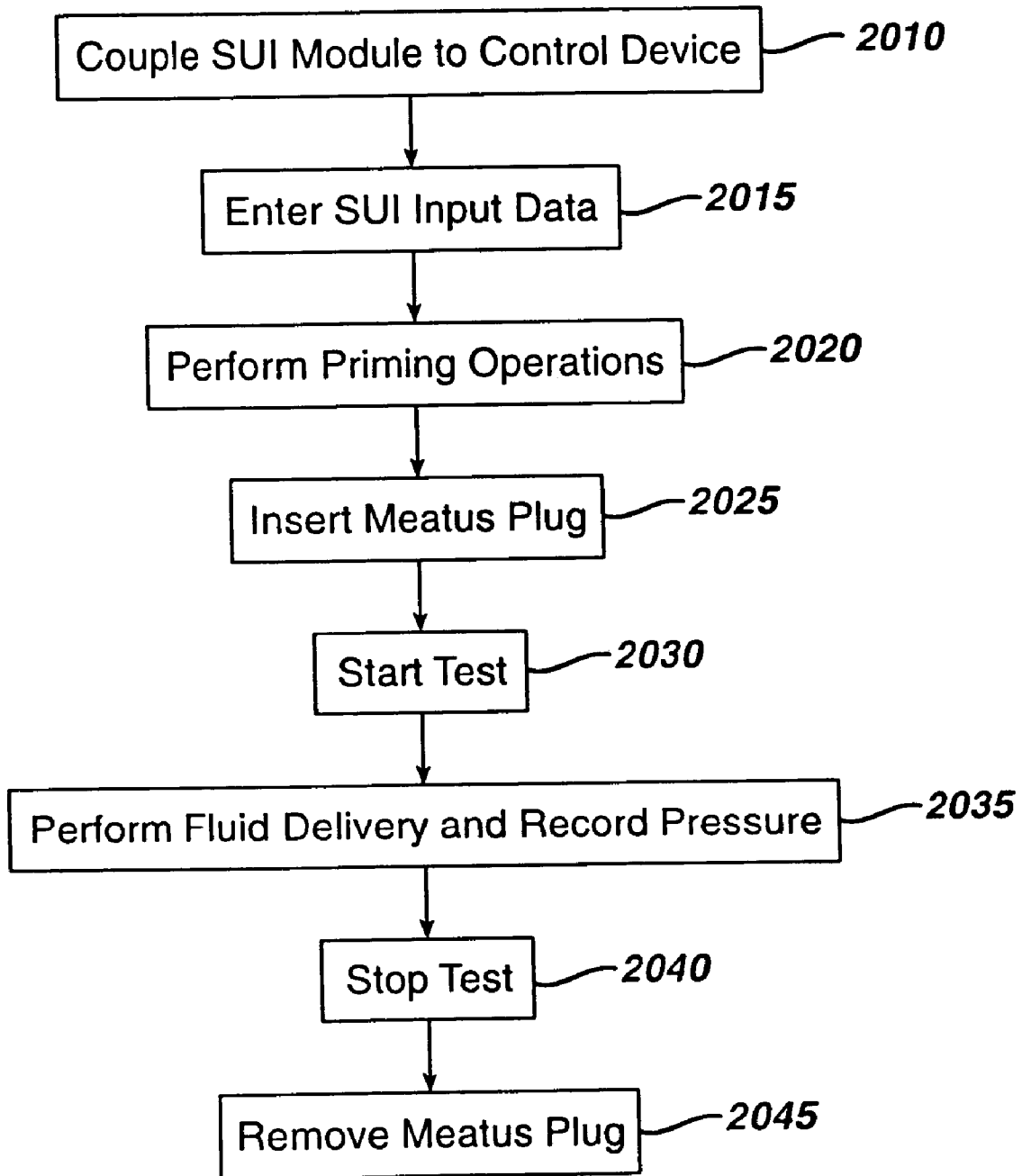
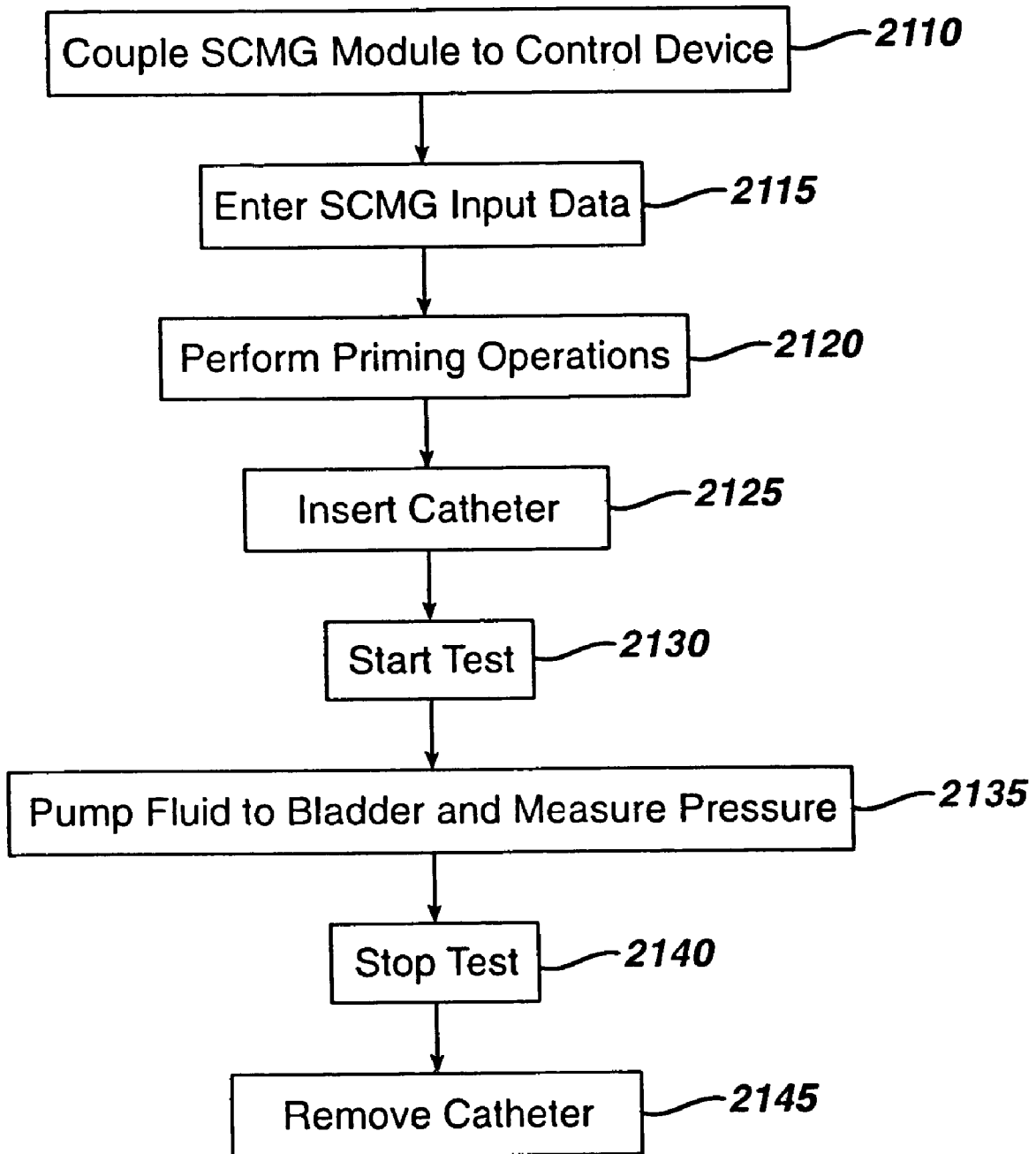


FIG. 19

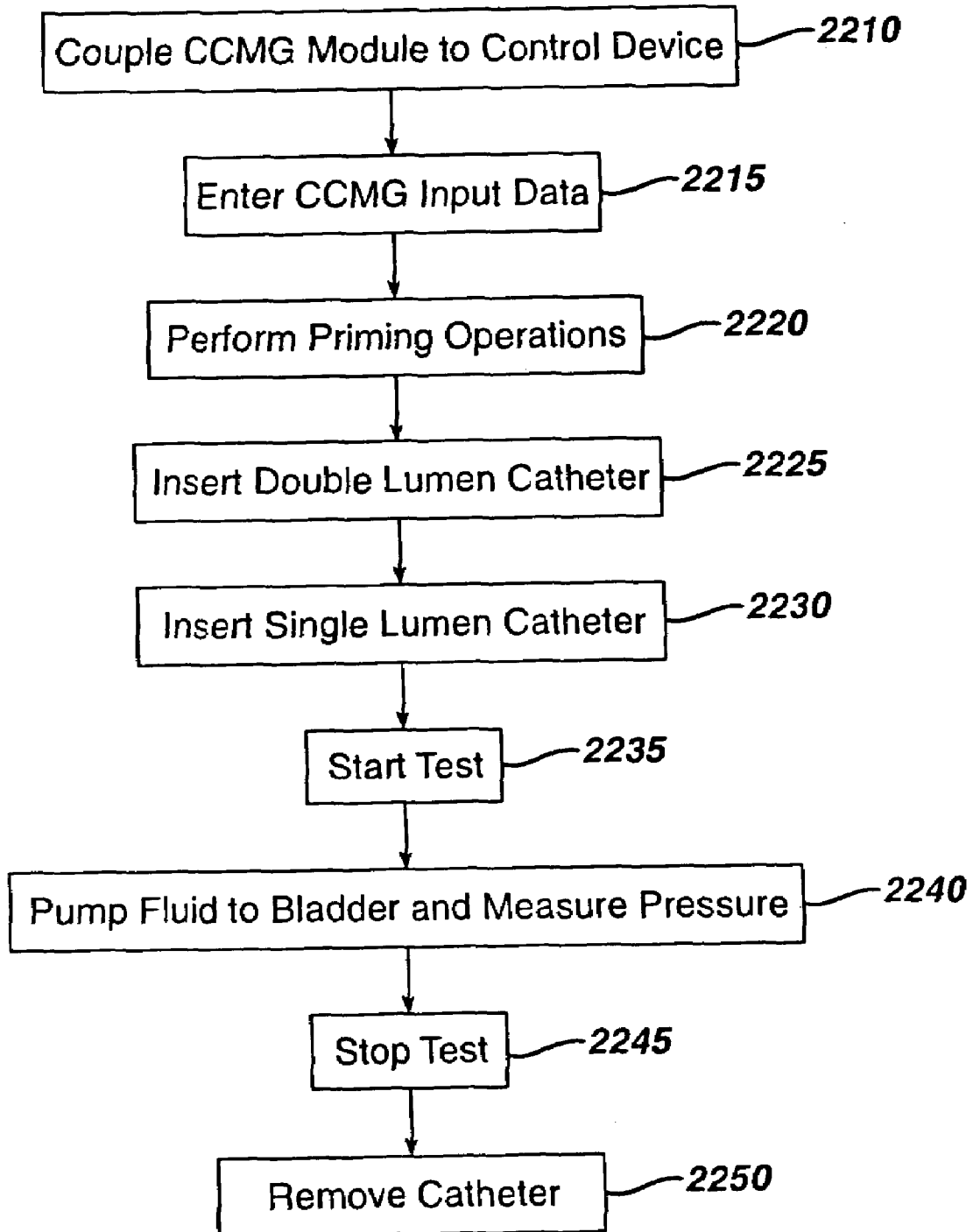
**FIG. 20**

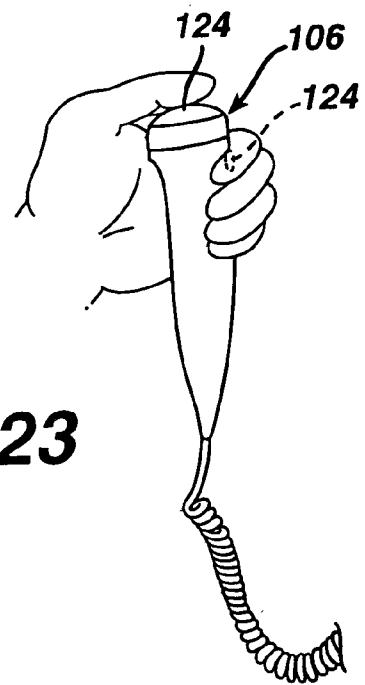


# FIG. 21

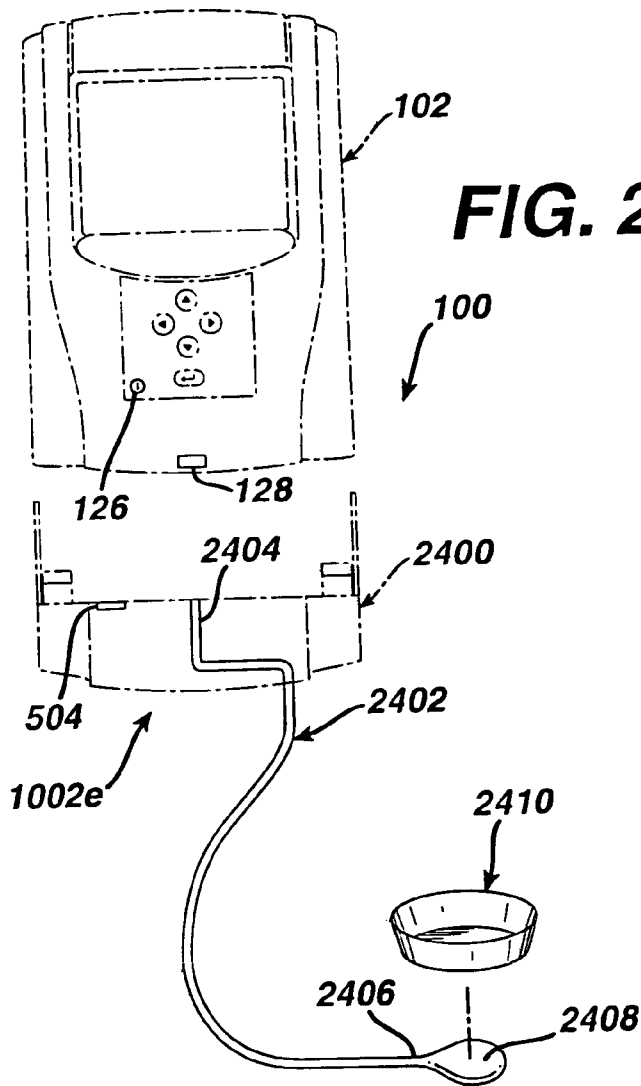


**FIG. 22**



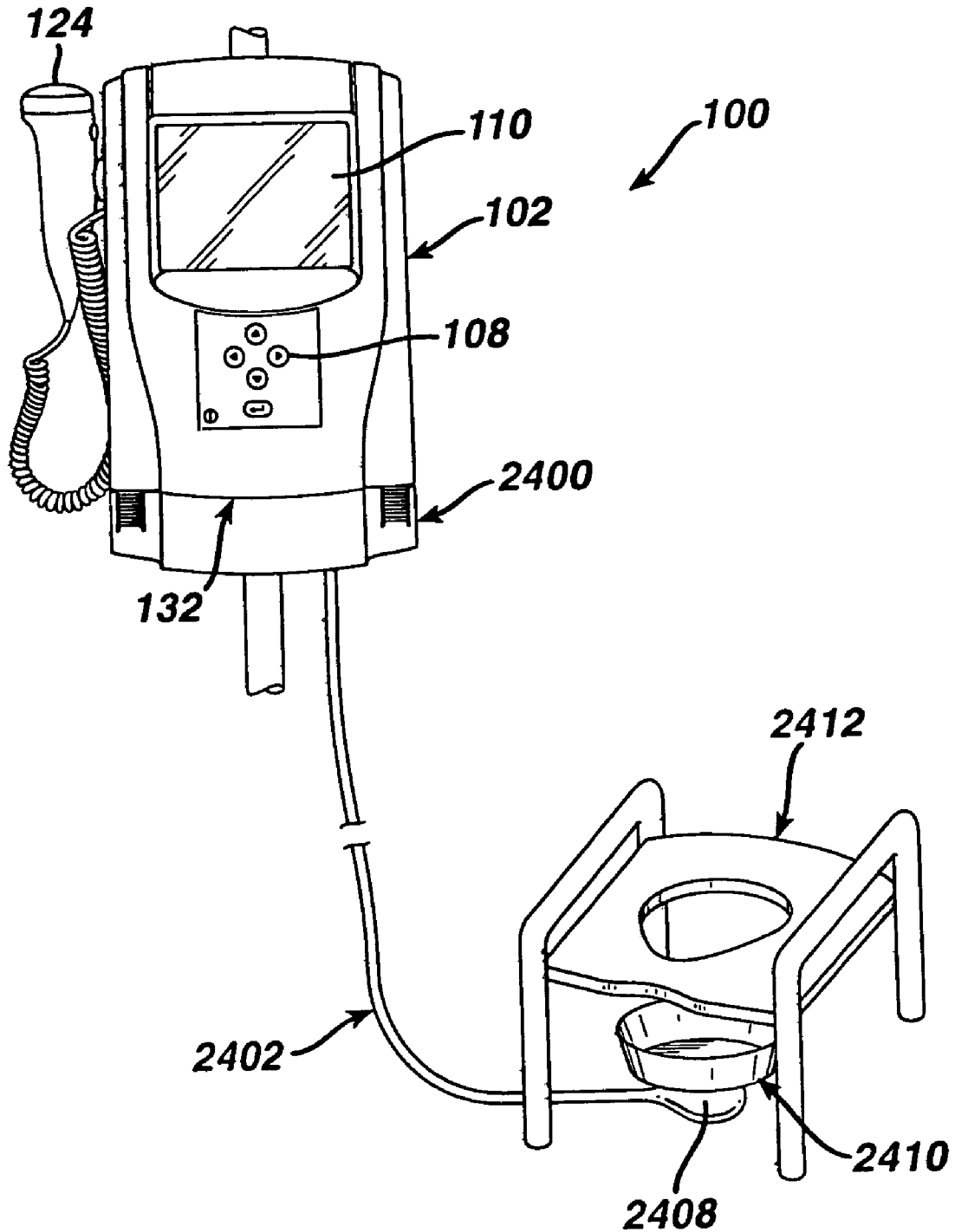


**FIG. 23**



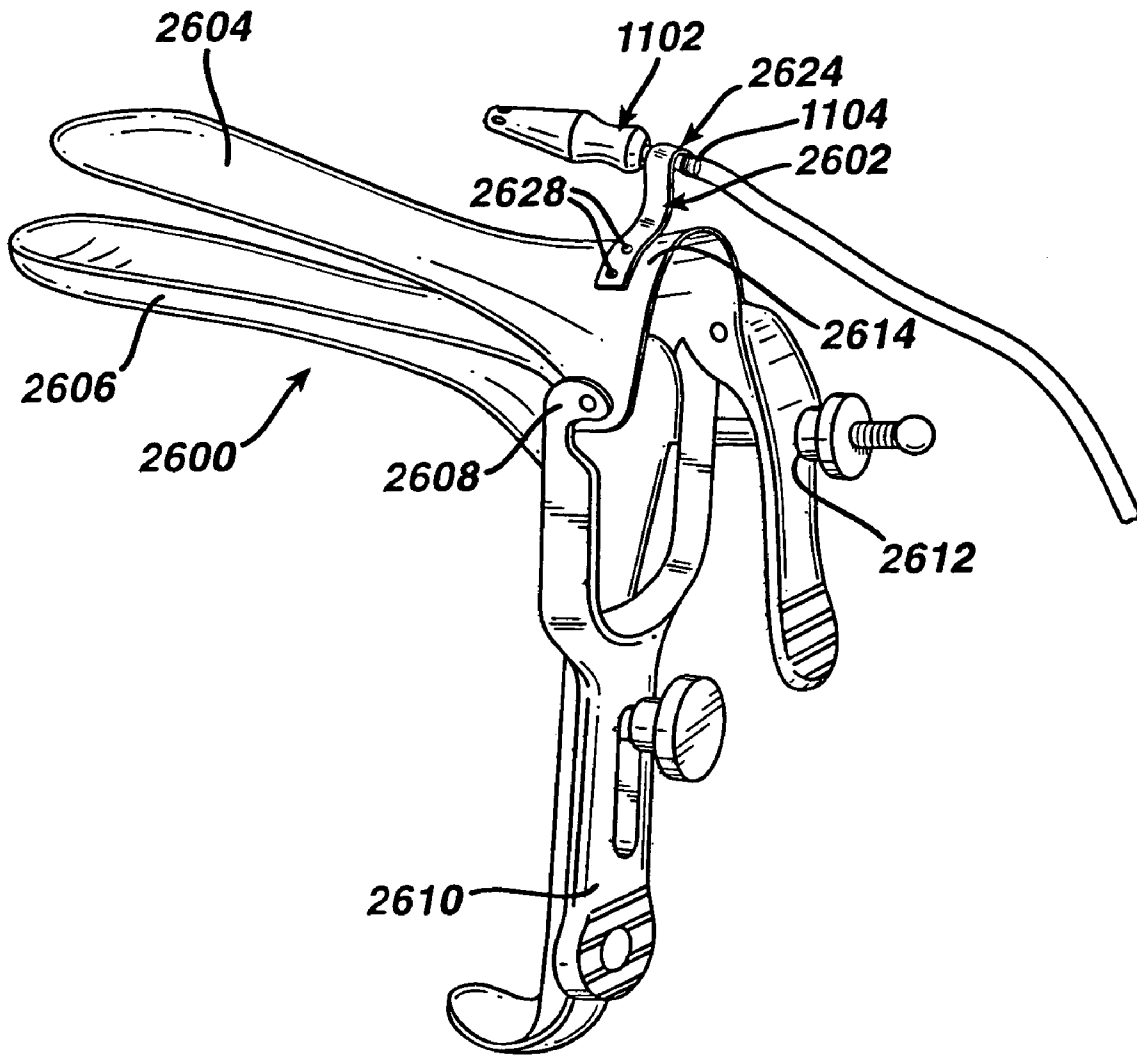
**FIG. 24**

# FIG. 25

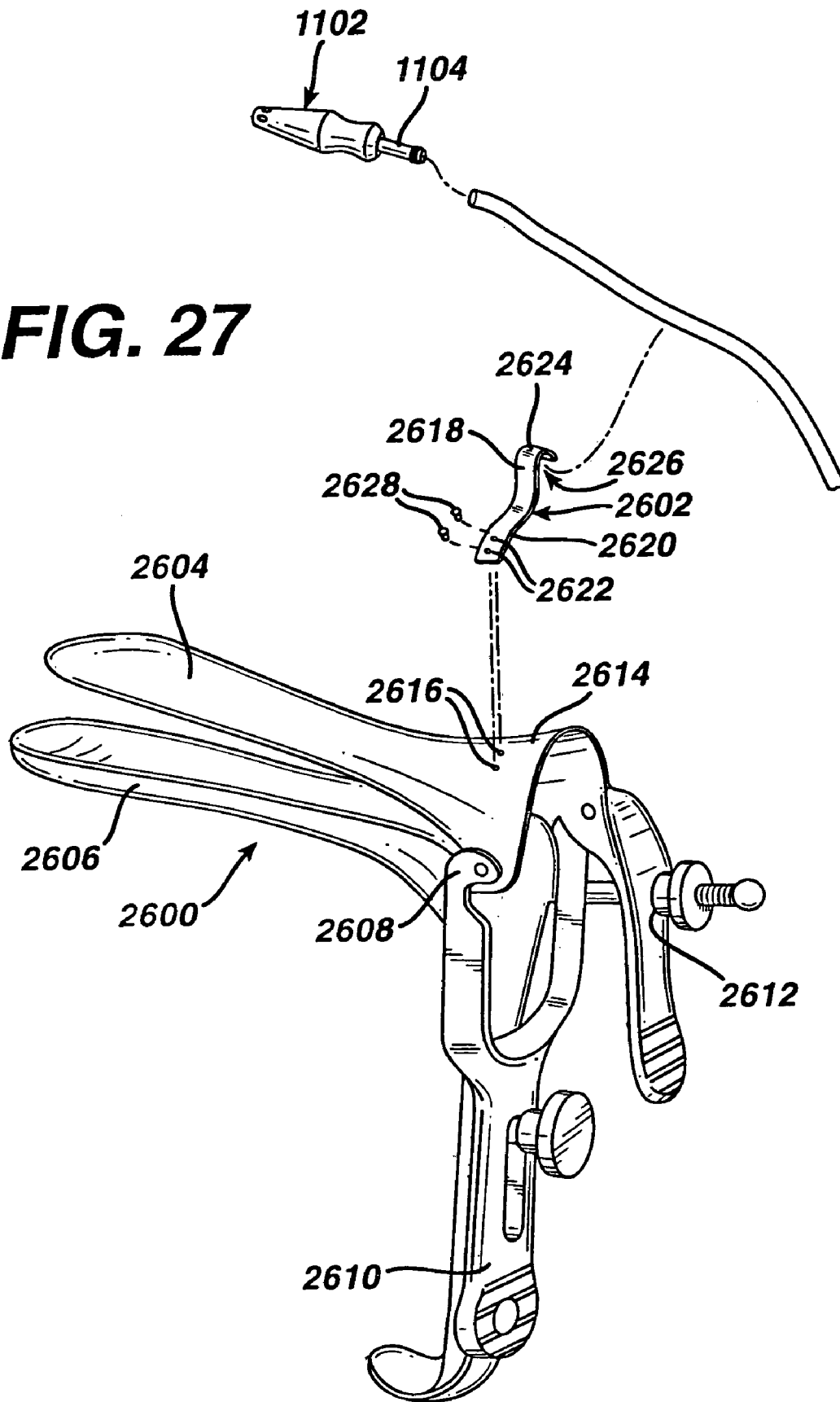




**FIG. 26**



**FIG. 27**



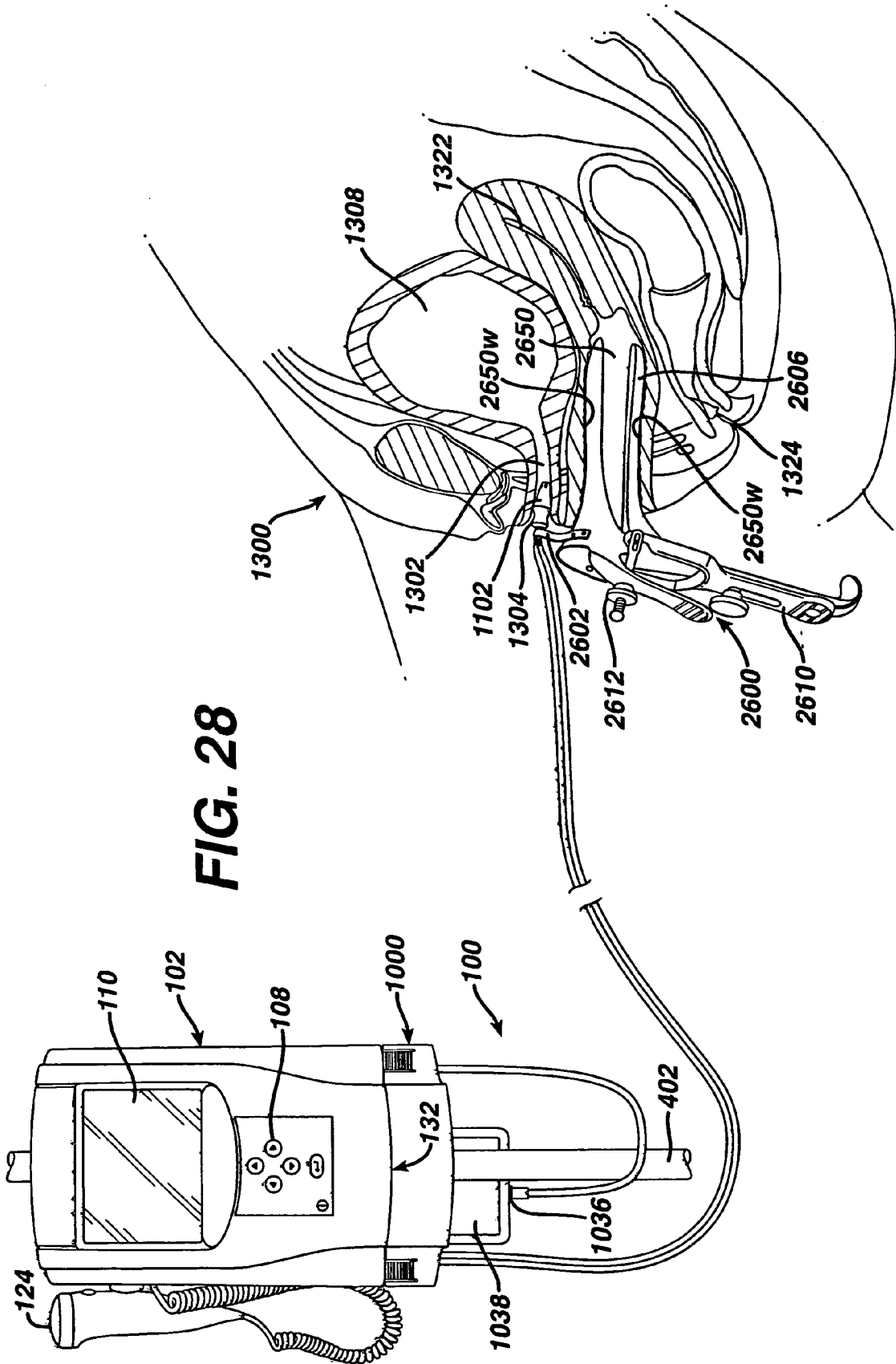
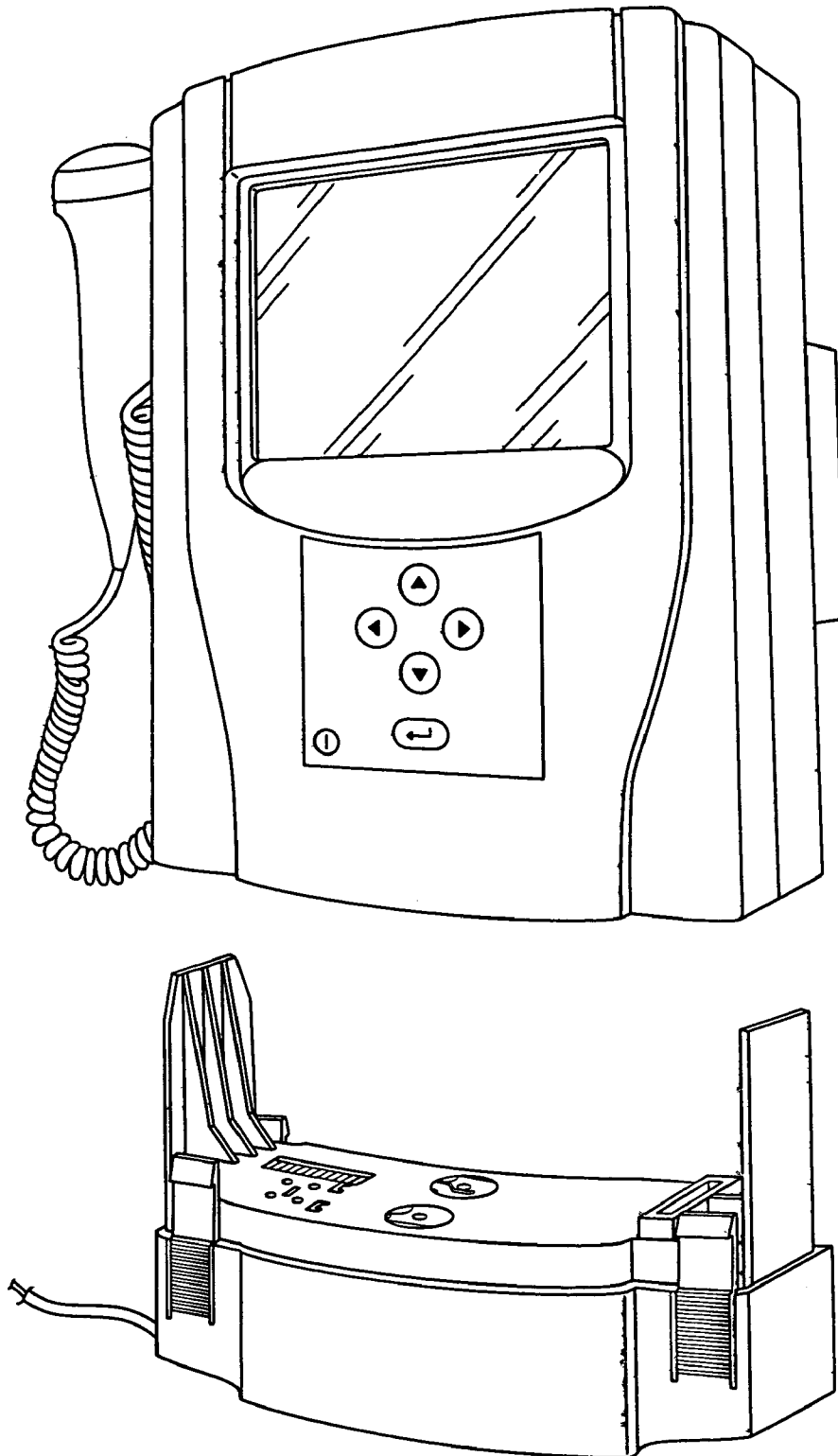


FIG. 28

**FIG. 29**



## SYSTEM AND METHOD FOR ASSESSING DETRUSOR INSTABILITY

### CROSS REFERENCE TO RELATED APPLICATIONS

The present invention is a continuation-in-part of earlier filed U.S. patent application Ser. No. 10/183,790, filed on Jun. 27, 2002, now U.S. Pat. No. 7,052,452 which claims the benefit of earlier filed U.S. provisional patent applications, Ser. Nos. 60/302,069, filed on Jun. 29, 2001 and 60/372,579, filed on Apr. 12, 2002, all of which are incorporated by reference in their entirety herein.

### FIELD OF THE INVENTION

The present invention relates generally to a system and a method for assessing urinary function. More particularly, the system and method is used for testing the integrity of the urinary system for diagnostic purposes, and in particular for diagnosing urge incontinence.

### BACKGROUND OF THE INVENTION

Women account for more than 11 million of incontinence cases. Moreover, a majority of women with incontinence suffer from stress urinary incontinence (SUI). Women with SUI involuntarily lose urine during normal daily activities and movements, such as laughing, coughing, sneezing and regular exercise.

SUI may be caused by a functional defect of the tissue or ligaments connecting the vaginal wall with the pelvic muscles and pubic bone. Common causes include repetitive straining of the pelvic muscles, childbirth, loss of pelvic muscle tone and estrogen loss. Such a defect results in an improperly functioning urethra. Unlike other types of incontinence, SUI is not a problem of the bladder.

Normally, the urethra, when properly supported by strong pelvic floor muscles and healthy connective tissue, maintains a tight seal to prevent involuntary loss of urine. When a woman suffers from the most common form of SUI, however, weakened muscle and pelvic tissues are unable to adequately support the urethra in its correct position. As a result, during normal movements when pressure is exerted on the bladder from the diaphragm, the urethra cannot retain its seal, permitting urine to escape. Because SUI is both embarrassing and unpredictable, many women with SUI avoid an active lifestyle, shying away from social situations.

SUI is categorized into three types. Type I and Type II are directed to urethral hypermobility. Type III is directed to intrinsic sphincter deficiency (ISD). Diagnosis of ISD requires urodynamic evaluation. Urodynamic evaluation involves complex and invasive equipment and often requires referral to a specialist trained in urodynamic evaluation.

Existing diagnostic systems all require a catheter be passed trans-urethraly to measure pressure, such as Leak Point Pressure (LPP) or Urethral Pressure Profile (UPP). An exemplary system is disclosed in publication (WO 0023127). Detection of LPP requires that a pressure sensor and catheter be passed trans-urethraly. The bladder is filled, and pressure is recorded. Fluid leakage from the urethral opening (meatus) corresponds to the maximum pressure the urethral sphincter can resist, or LPP. During the UPP measurement procedure a pressure sensor tipped catheter is placed trans-urethral into the bladder and then withdrawn at a constant velocity. The pressure profile along the urethra, from bladder neck to meatus is recorded.

Other parameters may also be measured, such as abdominal pressure and urinary flow. A cystometrogram (CMG) is a pressure study that simultaneously measures intra-abdominal, total bladder, and true detrusor pressures. Uroflometry measures urine flow rate visually, electronically, or via a disposable system. Video Urodynamic Systems also exist that simultaneously measure parameters, as described above, with radiographic visualization of the lower urinary-tract.

Existing urodynamic evaluation systems are complex, expensive, and require extensive training. Furthermore, existing urodynamic systems often require at least 30 minutes to complete a test. This exceeds the time available for most standard physician office visits and results in referral to a specialist. No urodynamic system exists that can quickly and inexpensively record useful urodynamic measures, without passing a catheter or instrument trans-urethraly.

Other than SUI, urge incontinence also accounts for a great number of cases of urinary incontinence. Urge incontinence is caused by overactive bladder muscles. Detrusor instability is one cause of urge incontinence. Detrusor instability involves spontaneous and unprovoked involuntary contractions of the detrusor muscle (the muscles that make up the bladder wall) during filling of the bladder that cannot be suppressed. Currently, diagnosis of detrusor instability similarly involves the use of invasive and uncomfortable transurethral catheters. The bladder is filled with fluid using such catheters, and the pressure is monitored to detects spikes in pressure, which indicate detrusor muscle contractions. Diagnosis using transurethral catheters is often complicated by the fact that the catheter often aggravates the delicate muscle structures of the urethral sphincter and bladder neck. Thus, the transurethral catheter actually aggravates and disrupts the very structures that the measurements seek to evaluate, potentially giving misleading results.

With regard to urge incontinence, there remains a need for an improved system and method for assessing detrusor instability.

### SUMMARY OF THE INVENTION

The present invention provides a method for diagnosing detrusor instability including the steps of using an insert member having a channel therethrough positioned distal of the urethral sphincter, creating a substantially fluid tight seal to substantially block fluid flow into or out of the urethral canal other than through the channel, infusing fluid from a fluid source through the channel in the insert member and into the urethral canal at a location distal of the urethral sphincter, and measuring a pressure within the urethral canal at a location distal of the urethral sphincter as the fluid is being infused therein, wherein the infusing step further includes infusing fluid until the urethral sphincter opens, and thereafter until at least one detrusor contraction occurs. In alternate embodiment, the fluid is infused at rate of approximately 40-120 mL/min, and/or the fluid is infused for at least approximately 3 minutes.

In one embodiment, the method further includes providing data correlating to the measured pressure to a processor, and displaying on a display device measured pressure versus time. In yet another embodiment, at least a distal portion of the insert member is substantially conical in shape, and the insert member channel may also include an insert member channel inlet at a proximal end and an insert member outlet at a distal end including a plurality of apertures spaced apart about an outer surface of the distal end of the insert member.

3

In yet another embodiment, the insert member is coupled to a device for diagnosing urinary incontinence that includes a control device having a processor and a pump therein, and a test module removably coupled to the control device. The test module includes a tubing assembly coupled to the pump for pumping fluid therethrough, and having a first fluid conduit between a fluid inlet and a fluid outlet, the fluid outlet being coupled to the insert member and in fluid communication with the insert member channel. The fluid inlet of the first fluid conduit may be coupled to a fluid source. In another embodiment, the control device further includes a pressure sensor, and the test module further includes a pressure interface in fluid communication with the first fluid conduit and in communication with the pressure sensor so as to transmit pressure information thereto.

A method for diagnosing detrusor instability is also provided including coupling a test module to a control device, the test module including a tubing assembly having a first fluid conduit between a first fluid inlet and a first fluid outlet, and an insert member coupled to the first fluid outlet and having a channel therethrough in communication with the first fluid conduit so that fluid flowing through the first fluid conduit can flow through the insert member, coupling the first fluid inlet to a fluid source, inserting the insert member at least partially into a patient's urethral canal at a location distal of the urethral sphincter so as to substantially block fluid flow into or out of the urethral canal other than through the insert member channel, infusing fluid from the fluid source into the urethral canal through the first fluid conduit and insert member; and measuring the pressure within the urethral canal at a location distal of the urethral sphincter as the fluid is being infused therein, wherein, the infusing step further includes infusing fluid into the urethral canal until the urethral sphincter opens, and thereafter until at least one detrusor muscle contraction occurs.

Yet another method for diagnosing detrusor instability is provided including the steps of inserting an insert member having a channel therethrough at least partially into a patient's urethral canal at a location distal of the urethral sphincter, the insert member being dimensioned to substantially block fluid flow into and out of the urethral canal other than through the insert member channel, infusing fluid from a fluid source through the insert member channel and into the urethral canal at a location distal of the patient's urethral sphincter at a rate of approximately 40-120 mL/min, measuring pressure within the urethral canal at a location distal of the urethral sphincter as fluid is being infused therein, and providing data correlating to the measured pressure to a processor, wherein the infusing step further includes infusing fluid until the urethral sphincter opens, and thereafter until at least one detrusor contraction occurs.

These and other features and advantages of the present invention will become apparent from the following more detailed description, when taken in conjunction with the accompanying drawings which illustrate, by way of example, the principles of the invention.

#### BRIEF DESCRIPTION OF THE DRAWINGS

FIG. 1 is a perspective view of a one embodiment of a portable medical system according to the present invention;

FIG. 1a is a front view of one embodiment of a portable medical system according to the present invention;

FIG. 2 is a front perspective view of a control device according to the present invention;

FIG. 3 is a rear perspective view of the control device of FIG. 2;

4

FIG. 4 is a front elevational view of a control device in accordance with the present invention attached to a pole;

FIG. 4a is an exploded perspective view of one embodiment of a pole attachment mechanism;

FIG. 4b is a rear perspective view of the pole attachment mechanism of FIG. 4a;

FIG. 4c is a rear view of the pole attachment mechanism of FIG. 4a when not secured to a pole;

FIG. 4d is a rear view of the pole attachment mechanism of FIG. 4a when secured to a pole;

FIG. 5 is an exploded perspective view illustrating interaction of a control device identification mechanism and module identification components;

FIG. 5a is a schematic cross-sectional view taken across line 5a-5a of FIG. 5 prior to engagement of the control device with the test module;

FIG. 5b is a schematic cross-sectional view similar to FIG. 5a showing engagement of the control device with the test module;

FIG. 6 is a front perspective view of a module according to the present invention;

FIG. 7 is a schematic illustration of one embodiment of control device electronics assembly;

FIGS. 8a-8j are flow diagrams illustrating operation of control device software and graphical user interface components;

FIG. 9 is an alternate embodiment of a medical system according to the present disclosure;

FIG. 10 is a schematic representation of a portable medical system including an SUI module;

FIG. 10a is a partial cross-sectional view of one embodiment of a portable medical system including an SUI module;

FIG. 10b is an enlarged view illustrating a pressure transducer and filter according to one embodiment of the present invention;

FIG. 11a is a side elevational view and partial cross-section of one embodiment of a hand actuator in an assembled configuration;

FIG. 11b is a side elevational view and partial cross-section of the hand actuator of FIG. 11a in an unassembled configuration;

FIG. 11c is a side elevational view and partial cross-section of the hand actuator of FIG. 11a in an operational mode;

FIG. 11d is an alternative embodiment of a hand actuator according to the present invention;

FIG. 12 is an enlarged perspective view of one embodiment of a meatus plug device;

FIG. 13 is a schematic view of illustrating one embodiment of a urodynamic system in relation to a female urinary/reproductive system;

FIG. 14 is a schematic view illustrating internal components of one embodiment of a system including a SCMG module;

FIGS. 15-16 are schematic views of the system of FIG. 14 in relation to a female urinary/reproductive system;

FIG. 17 is a schematic view illustrating one internal components of one embodiment of a system including a CCMG module;

FIGS. 18-19 are schematic views of the system of FIG. 17 in relation to a female urinary/reproductive system;

FIG. 20 is a flow diagram illustrating steps for using the system of FIG. 10;

FIG. 21 is a flow diagram illustrating steps for using the system of FIG. 14;

FIG. 22 is a flow diagram illustrating steps for using the system of FIG. 17;

5

FIG. 23 is a perspective view of one embodiment of an input pendant according to the present invention;

FIG. 24 is a schematic view illustrating internal components of one embodiment of a system including a Uroflowmetry module;

FIG. 25 is a schematic view illustrating use of the system of FIG. 24;

FIG. 26 is a perspective view of one embodiment of a vaginal speculum assembly in accordance the present invention;

FIG. 27 is an exploded perspective view of the vaginal speculum assembly of FIG. 26;

FIG. 28 is a schematic view of one embodiment of a urodynamic system and speculum assembly in relation to the female urinary/reproductive system; and

FIG. 29 is an exploded perspective view of a battery charger module that can be used in conjunction with the control device.

#### DETAILED DESCRIPTION OF THE EMBODIMENTS

FIGS. 1 through 26 illustrate generally various systems and methods for assessing urinary function and/or components of such systems and methods. Although the systems and methods disclosed herein are described in detail in relation to the female urinary system, it is to be understood that the present invention can readily be adapted for use in assessing male urinary function as well. Further, those skilled in the art will recognize that inventive principles, apparatus and methods disclosed herein may also have application to assessing function in other areas, such as coronary function or pulmonary function. The present invention is to be limited only by the claims set forth herein.

Referring now to FIGS. 1 and 2, one embodiment of a portable medical system 100 is illustrated having particular application for assessing urinary function. The system 100 includes a control device 102 that controls operation of the system, at least one module 104 that can be removably coupled to the control device, at least one input device, such as the illustrated input pendant 106 and/or keypad 108, and at least one output device, such as the illustrated display screen 110. As will be described in more detail below, the control device 102 is designed to be removably coupled to any one of a plurality of testing modules 104 at any given time. As each module is uniquely suited to support a different type of diagnostic test or medical procedure, the resulting diagnostic system is not only readily portable, but is also extremely versatile in that the single control device, in conjunction with a plurality of small test modules, is capable of performing an array of diagnostic tests or other procedures. The system has particular application useful for assessing urinary function in that it provides a portable, modular system in contrast to the non-portable, expensive, and cumbersome equipment that is currently used for assessing urinary function. In addition, as will also be described in greater detail below, the present invention can perform tests quicker, and in a manner that is less uncomfortable and less invasive for a patient.

The control device 102 includes a housing 112 for housing various components, including one or more batteries 114, an electronics assembly 116, a pump device 118 including a motor, and various other circuitry. Batteries supply power to the control device 102, and are contained within a battery compartment 120 that is accessible by removing the battery cover 122 that forms part of the housing 112. The control device further includes an input keypad 108 for

6

allowing a user to input data (such as patient name or other identifier, numeric identifiers, patient history, date etc.) and an input pendant 106 including one or more switches 124 that allow user input of additional information (i.e., event input based on patient feedback), and an activation switch 126 for turning the device on and off. The pump device 118 and at least one pressure transducer 128 are also contained within the housing. The pump device is electrically coupled to the battery and the electronics assembly, and the pressure transducer is electrically coupled to the electronics assembly. The control device 102 may also include a pole mounting mechanism 400 for mounting the control device on a pole such as the pole of an IV solution caddy 402 including a hook 404. One embodiment of a pole mounting mechanism is illustrated in FIGS. 4a and 4b. The device may also include an interface 130 including appropriate electrical pinouts to enable the control device to communicate for purposes of battery recharging or printing of patient test data.

As indicated above, any one of a plurality of modules 104, such as diagnostic test modules, can be removably coupled to the control device 102, and the control device is designed to uniquely identify the attached module, and perform routines specific to that module. Thus, the control device includes a module detection mechanism 500 capable of identifying the attached module that is electrically coupled to the electronics assembly (see FIG. 5). This module detection mechanism includes one or more identification probes 502 that project from the interface side 132 of the control device and are electrically coupled to the electronics assembly. The modules 104 may include one or more apertures in the module housing 506 that are designed to receive therein the identification probes when the module is removably coupled to the control device. When so coupled, the identification probes will bridge one or more module identification elements or components 504, such as resistors, capacitors, fuses or other suitable electronic components, present within the module. The identification probes are electrically coupled to the electronics assembly 116 (described more fully below), which determines a value, such as resistance, associated with the module identification element(s) that they bridge. Each module is designed to have a value so that identification of this value by the electronics control assembly enables the control device to uniquely identify the attached module. In a preferred embodiment, the control device may include one or more sets of identification probes 502 at different locations, and different modules have a module identification components 504 at different locations. The location, as detected by the control device, identifies the attached module. In yet another embodiment, the module identification component(s) may be coupled to an exterior side of the module housing so that apertures in the module housing are not required.

The module further includes at least one coupling element 600 for removably coupling the module to the control unit (see FIG. 6). In the illustrated embodiment, the module includes four coupling elements placed toward the ends of each of the front and rear faces 602, 604 of the test module. Each coupling element contains a tab element 606 that engages a corresponding ridge 607 (best seen in FIG. 5) on an interior surface of the control device when the module is removably coupled to the control device. To couple the module to the control unit, the coupling elements are depressed slightly in the direction indicated by the arrow in FIG. 6. The module is then aligned with the control device as shown in FIG. 1, and the coupling elements released to allow engagement with the corresponding ridges described

above. The module can subsequently be removed from the control unit by once again depressing the coupling elements and removing the module from the control device.

Finally, the module housing 506 includes first 608 and possibly second 610 ports therein as shown in FIG. 6. Each of the first and second ports are configured so as to define a recess capable of receiving a control device pressure sensor, such as a pressure transducer, therein when the module is coupled to the control device. For example, a first control device pressure transducer 128 is received within the first port recess 608 and comes in physical contact with a pressure interface 1024 (see FIG. 10) so that pressure changes at the pressure interface can be transmitted to and detected by pressure transducer 128 and converted to electrical signals that are sent to the electronics assembly for interpretation. Similarly, the second port 610 also defines a recess capable of receiving therein a second control device pressure transducer 1030. The first and second ports are further configured to form an airtight seal with the control device when coupled thereto, preferably by incorporating sealing elements such as gaskets or the like. Individual modules and their operation in conjunction with the control device will be described in greater detail below.

As indicated above, contained within the housing 112 of the control device 102 is an electronics assembly 116 (see FIG. 7) that is designed to control operation of the pump device 118, to acquire and format data from the pressure transducer(s), to drive a display 110 and/or other output device, and to accept and interpret input data, such as from switches 108, 126, and/or 124. The electronics assembly 116 consists of an integrated circuit board 702, hardware interfaces to the pump device 708, pressure transducer 706, 707, display 709 and switches 703, 704 and 705; and a microprocessor 710. The microprocessor 710 serves as the main controller for the diagnostic system and is supported by the custom integrated circuit 702 and powered by the batteries. Also included are interface connection elements including an electronic module identification connection 712 to the electronic detection mechanism 500, and electronic connections 714 that enable downloading of data to a printer or other external device.

The microprocessor 710 is programmed with a custom program file. In the illustrated embodiment, this software has multiple functions. First is the acquisition of input from the operator. This input data is captured from the input keypad 108, and/or switches 124, 126, pressure transducer(s) or other input device, depending upon which test module is in use. The software also controls operation of the pump device 118. Input data is interpreted and appropriate signals are sent to the pump device motor via the integrated circuit board 702. Yet another function is to acquire and condition data from the pressure transducer(s). This data is then sent in the appropriate format to the display 110, along with applicable pump device data in the form of volume or time information. Finally, as indicated above, the software receives input from the module detection mechanism 500 and interprets this input to determine which test module is coupled to the control device.

FIGS. 8a-8i are flow diagrams illustrating operation of the diagnostic system software and features of the system graphical use interface for a preferred embodiment of the invention. When the system is powered on, the user is first presented with a welcome screen. While this screen is being displayed the system is undergoing a self-test routine 802 to test the integrity of system hardware and software components. Upon completion of this routine, the user is provided with information relating to the amount of available system

memory 804. Following the pressing of any key 806 on input device 108 by the user, the system identifies the attached module 808 as described above, and following such identification, the processor executes a software subroutine specific to the identified module. For each software subroutine, however, a main menu is displayed next, such as that indicated by reference numeral 810. In the illustrated embodiment, the main menu includes six possible selections. "Utilities" enables the user to access various system features, such as setting the date, time etc, or adjusting the brightness or contrast of the screen; "Quit" terminates the session; "Patients" enables the user to access any previously stored data relating to other patients and tests already performed; "Prime" initiates the pump priming process; "Patient ID" enables the user to enter a patient identification number; and "Test" initiates a software subroutine specific to the attached module to carry out the desired test procedure. In the presently described embodiment, the software and user interface associated with the "Prime," "Utilities," "Quit," and "Patient ID" selections are substantially the same for each software subroutine. The "Test" and "Patients" selections, however, are different for each test module. Each of these selections will be described in greater detail below.

As is illustrated in FIG. 8a, the first time the main menu is displayed both "Test" and "Prime" appear in a different color or shade from the other options, indicating that they are not currently available. This is to ensure that patient identification information is entered before proceeding with any priming or testing procedures. The user may select the "Patient ID" option by scrolling using the appropriate arrows on the input keypad 108. Following this selection the Patient ID screens appears 820 (FIG. 8b). In the illustrated embodiment, the patient ID consists of a nine digit integer. To enter the patient ID, the user scrolls to a selected blank using the left and right arrows and/or left and right arrows on the input keypad 108 (824) to select desired numbers. Once the desired number is selected, the user presses ENTER; the selected number will then appear in the rightmost blank. Subsequent numbers are selected as described above, and will appear in the rightmost blank while previously selected numbers move to the left. This process is completed until all blanks are filled in. In one embodiment, there is a default value for each blank, such as 0, and the user may proceed with testing by accepting the default patient ID number consisting of all 0's. Once complete patient identification information is entered, the user selects the "Main Menu" option 832, which returns to the main menu screen. At this point, however, the "Prime" option become available 834 (and "Patient ID" is no longer available).

Before performing any test that requires fluid to be infused into the patient, priming operations must be performed to ensure that the fluid infusion lines (tubing) are filled with fluid and not air. Referring now to FIG. 8c, the user selects the "Prime" option 840 by using the arrow keys to select the option, and then pressing the enter key. The Prime screen then appears. According to one embodiment, the Prime screen includes two options as indicated at 842: "Prime" or "Main Menu." In another embodiment, the Prime screen is particular to each module, and may present only one option to initiate priming. Selecting the Prime option causes the pump to start and run for a predetermined amount of time, such as 20 seconds, and then automatically shuts off. The user is then presented with a screen 846 at which the user can accept the prime as complete (MAIN), or choose to reprime (PRIME). When priming is accepted as complete, the main menu once again appears, this time with "Test" as



an option **848**. In another embodiment, priming operations may be specifically tailored for different test modules. For example, as will be described in more detail below, the SUI test modules includes a hand actuator including an activation button **1118** or **1128**. The system may be designed so that following display of the Prime screen, pump priming operations can be initiated by depressing the activation button.

With priming complete, testing can begin. As indicated above, testing procedures depend on the attached test module, and accordingly, the software and graphical user interfaces relating to each test module will be discussed in greater detail below in conjunction with the detailed description of each test module.

In an alternative embodiment of the invention illustrated in FIG. 9, the control device **102** is electrically coupled to a laptop/standard computer **900**, and the microprocessor and associated software reside in the computer.

As indicated above, the diagnostic system described herein has particular application to urodynamics in that it enables clinicians to diagnose a plurality of urinary incontinence problems when used with specifically designed testing modules (to be discussed hereinafter). As a miniaturized urodynamic tool, the control device **102** in conjunction with modules **104** can measure urethral resistance pressure (URP), detrusor instability (DI), voiding flow (Uroflometry), and bladder dysfunction (Cystometrogram (CMG)). As will be described further below, URP is a new and unique approach to urodynamic measurement of stress incontinence that is less invasive for a patient, and faster than currently known and used diagnostic tests. Uroflometry is the study of micturation over time. CMG is the study of bladder or detrusor instability. A major advantage of the diagnostic system disclosed herein is that it can achieve all of the diagnostic tests described above with a portable unit that can be used in any office exam room, removing the need for the reservation or scheduling of a specialized urodynamic room, and the need for the complex equipment currently required for such tests. The urodynamic system is easy to use and does not require advance training. Use of the disclosed system makes testing more comfortable for patients by enabling faster set up, shorter test time, and less invasive procedures.

In actual use, different modules can be removably coupled to the control device **102** to conduct these different urodynamic tests. Each module performs a different and distinct test. These modules include, but are not limited to, a stress urinary incontinence (SUI) module for measurement of urethral resistance pressure (URP); a simple CMG module for measurement of bladder instability; a complex CMG module for measurement of bladder instability; detrusor instability module (DI) which measures detrusor instability in a different and non-invasive manner relative to CMG, and a uroflometry module for the study of micturation over time. Modules may be suitably adapted to either male or female incontinence diagnosis.

Before proceeding with a discussion of individual test modules, to assist the reader a brief overview of the female urinary system will be described with reference to FIG. 13. The female urinary system **1300** includes an elongated urethral canal **1302** having a urethral meatus (entrance) **1304** and having a substantially circular-shaped urethral sphincter muscle **1306** attached thereto, and a bladder cavity **1308** surrounded by a detrusor muscle **1310**. The detrusor muscle **1310** also surrounds and supports the urethral canal **1302**. The bladder cavity **1308** is in close proximity to the abdominal wall **1312**, the pubis bone **1314**, the pelvic floor **1316**

(levator ani muscle), the vaginal canal **1318**, the clitoris **1320**, the uterus **1322** and the anal sphincter muscle **1324**. Individual testing modules will now be described in detail.

#### Stress Urinary Incontinence Module

FIGS. 10-13 illustrate one embodiment of a stress urinary incontinence testing module (SUI) **1000** for diagnosing the involuntary loss of urine during physical activities such as coughing, sneezing, laughing or lifting. The SUI testing module **1000** includes a SUI module housing **1002** that can be removably coupled with the control device **102** as described above. The module housing may be in the form of a plastic disposable cartridge. Within the module housing is a tubing assembly **1004** including a fluid inlet **1006**, a fluid outlet **1008**, and a first fluid conduit **1010** extending therebetween. Tubing loop **1012** forms part of the tubing assembly and is positioned so that, when the SUI testing module is coupled to the control unit, the stator **1014** of the pump device **118** in the control unit **102** cooperates physically with the tubing loop **1012** so that the pump device operates as a peristaltic pump to pump fluid through the first fluid conduit **1010**. To assist in this regard, a tubing guide **599** aids in positioning a portion of the tubing assembly so that it will properly and effectively engage the peristaltic pump. According to the illustrated embodiment, tubing guide **599** has a substantially U-shaped configuration, however, many other configurations are suitable, as the principles of operation of peristaltic pumps are well known in the art. Tubing member **1050** also forms part of the first fluid conduit. The module housing **1002** also includes a pressure chamber **1016** for dampening pressure fluctuations that may be caused by operation of the pump device. The pressure chamber **1016** is in fluid communication with the first fluid conduit **1010** via valve openings **1018a-c** of three-way valve member **1020**. The pressure chamber is filled primarily with air, but varying amounts of fluid may also be present. Positioned at a distal end of pressure chamber **1016** is a filter component **1022** designed to isolate fluid from electronic elements of the system **100**. In this regard, filter **1022** may be a hydrophobic filter that allows air to pass into pressure interface **1024**, but not liquid. When the testing module is coupled to the control device **102**, pressure interface **1024** is in physical contact with pressure transducer **128** of the control device so that pressure fluctuations within the pressure chamber **1016** and pressure interface **1024** can be transmitted to and sensed by the pressure transducer, and subsequently transmitted to the electronics assembly as indicated above. In this manner, the control device measures pressure within the first fluid conduit of the tubing assembly of the SUI testing module, which substantially corresponds to the pressure within the urethral canal as described more fully below.

The SUI testing module **1000** tubing assembly also includes a second tubing member **1025** having a channel therethrough forming a second fluid conduit between a proximal end **1026** and a distal end **1028**.

Referring now to FIGS. 11a-c, the SUI testing module may also include a hand actuator **1100** having and insert device such as a meatus plug device **1102** attached thereto. The meatus plug device **1102** (see FIG. 12) includes an attachment member **1104** at a proximal end **1106** coupled to a plug or insert element or member **1108** at a distal end **1110**, and a channel **1112** extending therethrough allowing fluid flowing through the first fluid conduit to flow through the meatus plug device. The distal end **1114** of the plug element may also include one or more transversely aligned apertures

or openings **1116** therein approximately equally spaced apart from one another around the exterior surface of the distal end. As the outer diameter of the distal end at the location of the apertures is less than the diameter of the inner wall of the urethral canal at that location (described more fully below), one or more of the apertures **1116** can be used for assurance of fluid flow into the urethra during actual operation.

In one embodiment, the hand actuator further includes a hand-sized housing or casing **1102** including therein an initiator element **1118** (FIGS. **11a-c**) that is in fluid communication with tubing member **1025**. Preferably, initiator element is an air bladder **1097** coupled to a distal end **1028** of the tubing member **1025**. The proximal end **1026** of tubing member **1025** coupled to a pressure interface **1026a** that is positioned so that, when the SUI testing module is coupled to the control device, pressure within tubing member **1025** can be sensed by pressure transducer **1030**. As a closed system, pressure on the activation button **1118** can be sensed at the pressure interface **1026a** by pressure transducer **1030**, and interpreted by control device **102** as a signal to initiate and/or deactivate the test.

The hand actuator **1100** further includes a fluid conduit **1050** extending between an outlet **1195** and an inlet **1194** that is coupled to (integrally or otherwise) an external tubing conduit leading to a fluid source, such as the first fluid conduit **1010** of the SUI test module. Alternatively, the hand actuator may be designed to include therein the fluid source. The fluid outlet **1195** is in fluid communication with the insert member channel of the meatus plug device. An activation device **1127** including a trigger **1128** extends through an opening **1118a** to an exterior of the casing. The activation device **1127** is movable between a first rest position (shown) and a second activated position. In the first position spring **1130** exerts force on coupling member **1132**, causing it to pivot relative to pivot element **953** and pinch the distal ends of at least tubing member **1050** to prevent fluid flow therethrough. When in the second position, movement of the trigger causes the coupling member **1132** to pivot to a point at which it no longer pinches tubing member **1050**. Further, trigger **1128** may also compresses air bladder **1097** to initiate testing as described above in connection with initiator element.

The plug element **1108** is configured so that, when inserted into the urethral meatus of a patient (see FIG. **13**), it will substantially block or prevent fluid flow out of the urethra, as well as into the urethra other than through the meatus plug device channel **1112**. Further, when inserted, the plug element is positioned distal of the urethral sphincter **1306** (toward the outside of the body) as shown in FIG. **13**. In the embodiment shown in FIG. **12**, the distal end or distal portion **1114** of the plug element is substantially conical in shape, and decreases in diameter toward its distal end **1114**. A proximal portion **1199** is configured to engage the inner wall of the urethral canal to substantially prevent fluid flow therebetween. Other shapes, however, are also possible so long as fluid flow into or out of the urethral is substantially blocked (other than through the meatus plug device channel) and the plug element remains located distal of the urethral sphincter. The meatus plug device **1102** is made of a biocompatible material, such as stainless steel or polypropylene. The meatus plug device may be disposable, but may also be made of a sterilizable material so that it can be reused.

The first fluid conduit **1010** of the tubing assembly also includes an elongated single lumen tubing member **1032** having a first end **1006** and a second end **1034** and a fluid

channel extending therethrough. A spike device **1036** is coupled to the first end **1006** of the single lumen tubing member for attachment to a fluid bag **1038** (having a fluid **1010** therein) in a manner well known in the art. As described above, the meatus plug device and first fluid conduit are coupled to one another such that fluid from the fluid source traveling through the first fluid conduit may pass through the insert member (via the channel therein) and into the urethral canal distal of the urethral sphincter. Further, as the first pressure interface **1024** is in fluid communication with the first fluid conduit and ultimately the urethral canal, pressure at the pressure interface substantially corresponds to the pressure within the urethral canal distal of the urethral sphincter.

Use of the system **100** including a SUI testing module **1000** is as follows. First, the SUI testing module is removably coupled to the control device **102** in the manner described above. The physical coupling causes the identification probes **502** of the control unit to engage the module identification element(s) **504** of the SUI testing module, enabling the control device to identify the SUI testing module. The physical coupling also brings pressure interface **1024** in physical contact with pressure transducer **128** as described above so that pressure changes at the pressure interface can be detected by the pressure transducer and transmitted to the electronics assembly for interpretation. The pressure interface **1026a** at the proximal end of tubing member **1025** similarly comes in contact with pressure transducer **1030** so that pressure within tubing member **1025** can also be detected. Finally, the tubing loop **1012** is brought into physical contact with the pump device **118** so that the pump device can drive fluid through the first fluid conduit by peristaltic motion, as described above.

As shown in FIG. **20**, once the SUI testing module **1000** is coupled to the control device **102** (**2010**), the operator enters appropriate input data into the keypad **108** or other input device (**2015**) for the SUI test (described in more detail below). This data is received and interpreted by the microprocessor **710** and applicable information is sent by the microprocessor to the display **110**. Priming operations are then performed (**2020**) to ensure that the first fluid conduit **1010** contains fluid. At this point, the microprocessor is ready to start the test routine.

The meatus plug **1102** is inserted into the meatus of the urethra (**2025**) and the test is started (**2030**) by pressing the activation button as described above. This in turn sends instructions to the pump device via the integrated circuit. The pump device then pumps fluid **1040** through the first fluid conduit **1010** and meatus plug device channel **1112** and into the urethral canal distal of the urethral sphincter (**2035**). As fluid pressure builds in the urethral canal **1302**, pressure in the pressure chamber **1016** also builds. This pressure is transmitted through the filter component **1022** and pressure interface **1024** to the pressure transducer **128**, which receives the pressure data and transcribes it into an electrical signal. The electrical signal from the pressure transducer is sent to the microprocessor **710** via the integrated circuit **702** where it is acquired and conditioned. The information is then sent to the display **110** via the integrated circuit. The microprocessor ends the test after a specified amount of time, or upon receipt of input from the user by sending an "off" signal to the pump motor drive. Once the test has been completed, the operator disengages the activation button **1118** (step **2040**) and removes the meatus plug element from the meatus **1304** (**2045**).

Referring once again to FIGS. **8a-i**, and in particular FIG. **8d**, when the "Test" option is selected the SUI test can be

performed. The SUI Test screen appears **860**, and the user initiates the test by depressing the trigger **1128** or movable shell **1126 (862)** to allow fluid flow into the urethral canal as described above. The motor is then activated and the pump device pumps fluid into the urethral canal for a predetermined period of time, preferably 15 to 20 seconds. During this time a graph (see **860**) is continuously displayed illustrating measured pressure on the vertical axis (preferably in cm of water) versus time on the horizontal axis. As fluid is pumped into the urethral canal, pressure within the urethral canal distal of the sphincter continues to increase until that point in time at which the urethral sphincter yields (open) under the force of the pressure within the urethral canal. At that point the pressure curve becomes substantially flat, as illustrated in FIG. **8d**, since the sphincter is open and fluid is filling the bladder. The value of the flat portion of the curve is considered the "urethral resistance pressure (URP)," and can be obtained from the displayed graph. On completion of the test (after expiration of the predetermined time period the pump device stops), the graph remains, and the user is preferably provided with an option to adjust the software generated URP value (**860a**) before saving the test results. To adjust the URP value, the user uses the up and down arrows to manipulate a horizontal line which indicates the URP value that appears on the screen (**870**). When the ghost line is at the desired value, the user presses enter (**872**).

Once the final URP value is displayed, a Save/Delete screen **874** is overlaid on the screen. If the user selects the "Save" option, the test results are saved in memory. If the user selects "Delete" from the Save/Delete screen **874**, the user is then presented with the Save Test screen **876**. If "Delete" is chosen the test is deleted, but if "Cancel" is selected, the user is returned to the Save/Delete screen.

According to one embodiment, test results for up to three out of six possible tests may be stored. Once three tests have been stored or six tests have been run, whichever comes first, the control unit **102** will disable the module identification component **504** via the identification probes **502**. After testing is complete, the user may return to the main menu by selecting the "Menu" option from the Test Complete screen.

One option available from the Main Menu, as stated above, is "Patients," which allows the user to access patient and test data previously stored. According to one embodiment illustrated in FIG. **8h**, when "Patients" is selected from the Main Menu, a Patients Screen **891** appears. On this screen, options for each patient and test for which data has been stored **892** are presented and selection of one of these options causes a Patient Test Menu **893** to be displayed (FIG. **8i**). Selecting "Delete" **896** will present the user with the option to delete the stored data for that patient/test, and selecting "Print" **895** will enable the user to print the stored data. The Print option will only be available (will not be greyed out) when the control device is coupled to a cradle, or otherwise appropriately coupled to a printer. Selecting "View Test" will cause a Patients Test screen **898** or **899** to appear depending on whether stored data is a CMG (**898**) or a SUI (**899**) data set. The Patients Test screen may vary depending on the test module that is attached. For example, for the SUI stored data, the Patients Test screen is the screen illustrated by **899**, whereas for the CMG data (discussed below), the Patients Test screen is the screen illustrated by **898**. The Patients Test screens provide the user with the option to view data relevant to the particular form of test performed.

As indicated above, the results obtained from the SUI test is the urethral resistance pressure (URP), which is the back-pressure necessary to force open the urethral sphincter

muscle **1306** from the reverse or opposite direction from which fluid normally flows. A major advantage of the SUI testing module **1000** is that the insert or plug element **1108** of the meatus plug device **1102** only enters the external urethral canal (meatus) and does not cause any discomfort associated with passing a catheter through the internal urethral sphincter. Thus, the diagnostic system disclosed herein having a SUI module **1000** is less invasive and more comfortable for patients. Further, the testing procedure for the SUI module **1000** is easy to implement, quick to perform, and does not require advance training by the clinician and/or physician.

#### Detrusor Instability

Diagnosis of detrusor instability can be performed utilizing a module substantially identical to the SUI module described above and in a substantially identical manner, but with only minor modifications to the software (hereinafter referred to as the "DI" test or module). This diagnostic test is an alternative, less invasive test for determining detrusor instability as compared to the CMG test described in detail below. As indicated above and as illustrated in FIG. **8d**, when using the URP module the urethral sphincter is forced open from a reverse direction in approximately 10-20 seconds, resulting in the substantially flat line appearing on the display graph following this period of time (see FIG. **8d**). Detrusor instability can be detected using the same means for measuring pressure as the URP module, so long as the fill time is extended sufficiently beyond the time of sphincter opening. Using a fill rate of approximately 40-120 mL/min, the time should be extended for a sufficient amount of time until a detrusor muscle contraction is identified, which typically will be within 3 minutes. A detrusor muscle contraction will be identified in all patients, as this will eventually occur as the bladder is filled. However, by analyzing the pressure reading over this period of time (see FIGS. **8j** and **8i**), the timing of this detrusor contraction will be indicative of whether a patient experiences detrusor instability. The graphs of patients have detrusor instability will reveal detrusor contractions in advance of the point at which the bladder becomes full.

A representative graph is shown in FIGS. **8j** and **8i** (reference numeral **898a**) illustrating pressure (y axis) versus time (x axis). As can be seen, the initial portion of the curve **861** is identical to that achieved by using the URP module as described above. By extending the fill time as described above, subsequent detrusor activity **863a**, **863b** can be captured. Thus, to provide for a module that can detect detrusor instability, only minor programming changes need be made to the SUI module so that the fill time is extended.

Referring now again to FIGS. **8a-8j**, and in particular FIG. **8j**, when the "Test" option is selected the DI test can be performed. The DI Test screen appears **861** (with no trace initially), and the user initiates the test by depressing the trigger **1128** or movable shell **1126 (862)** to allow fluid flow into the urethral canal as described above. The motor is then activated and the pump device pumps fluid into the urethral canal at a predetermined fill rate, i.e., 40-120 mL/min, and for a period of time following opening of the urethral sphincter sufficient to capture contraction of the detrusor muscles. As indicated, a preferred amount of time is approximately 3 minutes. During this time a graph (see **861**) is continuously displayed illustrating measured pressure on the vertical axis versus time on the horizontal axis. As fluid is pumped in, pressure within the urethral canal increases

until the urethral sphincter opens, as described above. With the DI test, however, fluid is continually pumped in for an additional period of time. As shown, following opening of the urethral sphincter, the plot will become substantially horizontal. Following this, pressure spikes that are detected, i.e., **863a**, **863b**, are indicative of detrusor activity. On completion of the test (after expiration of the predetermined time period the pump device stops), the remaining steps are substantially identical to those set forth above in conjunction with the SUI test.

The above described method for diagnosing detrusor instability is less invasive, quicker, and more reliable than currently known methods. The present method avoids the need for invasive and uncomfortable transurethral catheters. Further, the results are more reliable in that there is no false or exaggerated detrusor activity caused by the presence of such a catheter.

#### Simple Cystometrogram (CMG)

The diagnostic system disclosed herein can also be used to perform both simple and complex cystometrograms. FIGS. **14-19** show both simple (SCMG) and complex cystometry (CCMG) systems for the testing of bladder function in which pressure and volume of fluid in the bladder cavity **1308** is measured during filling, storage and voiding. Urologists typically measure the static pressure relationship in the bladder of patients, this being termed as a cystometrogram (CMG), in order to determine the capacitance of the bladder as a function of pressure and volume.

Referring now to FIG. **14**, the SCMG testing module **1400** includes a module housing **1020b** that can be removably coupled to the control device **102** in the manner described above. The module housing **1020b** may be in the form of a plastic disposable cartridge. The SCMG testing module contains many elements that are similar to those described above in connection with the SUI testing module, and thus like numerals will be used for these elements. Contained within the module housing is tubing assembly **1004b** including a first fluid conduit **1402** between fluid inlet **1404** and fluid outlet **1406**. The tubing assembly also includes a second conduit **1408** between a distal end **1410** and a proximal end **1412**. Coupled to the proximal end is a filter **1022b** and pressure interface **1412** that contacts pressure transducer **128** to convey pressure information thereto when the SCMG testing module is coupled to the control device. Compliant tubing loop **1012** similarly forms part of the first fluid conduit, and couples with the pump device **118** in the same manner as described above in connection with the SUI module. The distal ends **1406**, **1410** of the first and second conduits are each coupled to respective proximal ends **1414**, **1416** of first and second tubing elements **1418**, **1420** of a dual lumen catheter **1422** so that the first and second conduits **1402**, **1408** between the proximal **1414**, **1416**, and distal **1460**, **1462** end of the dual lumen catheter are in fluid communication with channels in the first and second tubing elements **1418**, **1420** of the dual lumen catheter **1422**. This attachment may be accomplished by an adhesive bond, a solvent bond, an ultrasonic weld, or any other suitable type of attachment that creates a fluid tight seal. In another embodiment, the dual lumen catheter is an inflatable balloon catheter such as a Foley-type catheter, that includes a pressure sensor **1424** positioned at the tip of the catheter (see FIG. **16**). Any other suitable catheter may also be used, such as fiber optic or air charged catheters. The pressure sensor

may be a micro tip transducer, an air charged sensor, a fluid charged sensor, a fiber optic sensor or any other pressure measuring sensor.

Use of the diagnostic system to perform a SCMG will now be described in detail with reference to FIGS. **15**, **16** and **21**. First, the SCMG testing module is coupled to the control device in the manner described above (**2110**). The physical connection causes the identification probes **502** of the control unit to engage the module identification element(s) **504** of the SCMG testing module, enabling the control device to identify the SCMG testing module in the manner described above. The physical coupling also brings the pressure interface **1024b** in contact with the pressure transducer **128** so that pressure changes in the second fluid conduit can be detected by the pressure transducer. This coupling also causes the tubing loop **1012** to engage the pump device so that the pump can drive fluid through the tubing loop by peristaltic motion, as is also described above.

Once the SCMG testing module **1400** is coupled to the control device **102**, the operator enters input data appropriate for the SCMG test (**2115**). This data is received and interpreted by the microprocessor **710** and applicable information is sent by the microprocessor to the display **110**. Priming operations are then performed (**2120**). At this point, the microprocessor is ready to start the test routine.

The dual lumen catheter **1422** is then inserted into the bladder **1308** (**2125**) via the urethra **1304** and the test is started by pressing the input pendant switches **124** (**2130**). The microprocessor **710** receives the signal from the input pendant switches. Instructions are then sent to the pump device **118** via the integrated circuit **702**. The pump device then pumps fluid through the first fluid conduit **1402** and tubing element **1418** into the bladder (**2135**). As fluid volume builds in the bladder, pressure in the bladder also builds. This pressure is transmitted through tubing member **1420** and the second conduit **1408**, filter component **1022b**, and pressure interface **1024b**. The pressure transducer **128** receives the pressure data and transcribes it into an electrical signal. The electrical signal from the pressure transducer **128** is sent to the microprocessor **710** via the integrated circuit board **702** where it is acquired and conditioned. During the course of a typical SCMG test, the patient provides event input, such as feeling the need to void and/or the intensity of that feeling, which is input to the control device via input pendant switches **124**, as will be described more fully below. The microprocessor ends the test (**2140**) after a specified amount of time, or upon receipt of an "off" signal from input pendant switch **124**. Once the test has been completed, the operator removes the catheter **1422** from the bladder (**2145**). Following the test the software then exits the SCMG test subroutine, and the data storage routine is run to store and/or display results of the test.

Referring again to FIGS. **8a-i**, and in particular FIG. **8e**, when the "Test" option is selected the SCMG test can be performed. The SCMG Test screen appears **870a**, and the user initiates the test by depressing input pendant switch **124** (see FIG. **10a**) quickly. The pump device is then activated and pumping begins **872a**. In a preferred embodiment, fluid is infused into the patient's bladder at a rate of approximately 1 ml/sec. As such, this test may be approximately 16 minutes in duration, as opposed to approximately 15-20 seconds that may be required for the SUI test.

As the bladder is filling, the patient communicates the point in time at which he/she feels the initial sensation of needing to void, and the user presses the input pendant switch **124** to mark this point in time **873a**. The fluid infusion continues, and the user then marks the point in time

at which the patient feels the urge to void **874a**, and the point at which the patient feels an extreme, almost unbearable urge to void **875a**, or has voided. Upon this third marking, the fluid infusion ceases and the test is completed **876a**. During fluid infusion and after the test is complete, a graph is displayed illustrating pressure versus volume infused. After completion of the test a Save/Delete overlay **877** appears. Selecting "Save" and pressing enter saves the test data. Selecting "Delete" causes a Save/Delete screen **878** overlay to appear. Selecting "Delete" from this screen deletes the data, where as selecting "Cancel" from this screen returns to the Save/Delete overlay.

At any point between initiating pumping and completing the SCMG test, the user may pause the test by depressing and holding, or pressing firmly on the input pendant switch **880**, which causes the pump device to stop pumping fluid into the patient's bladder, and a Pause screen **881** (FIG. **8f**) to appear on the display. Selecting "Quit" causes a End Test screen **885** to appear, and if "OK" is selected the test is stopped **886**. If "Cancel" is selected the Pause screen reappears. If "Resume" **883** is selected from the Pause screen **881**, the SCMG test resumes where it left off (pumping begins again). If, however, "LPP" **882** is selected from the Pause screen **881**, assessment of the patient's leak point pressure (LPP) begins. No pumping of fluid occurs during this test. First, a LPP screen **887** appears and a blank graph is displayed. Pressure in centimeters of water is plotted on the vertical axis versus time on the horizontal axis. The patient then proceeds to exert pressure on the bladder as if attempting to void **888**. The user marks the point at which a leak occurs **889**, and the test is automatically completed after three minutes or three leaks, upon which the user is returned to the Pause screen **881**. LPP results may then be stored or deleted, the CMG test may be resumed, or the test can be terminated altogether.

#### Complex Cystometrogram

In reference to FIGS. **17-19**, the complex CMG (CCMG) testing module **1700** is similar to the SCMG testing module, but the tubing assembly also includes an additional single lumen tubing member **1702** having a proximal end **1704** and a distal end **1706** and a third conduit extending therethrough. The proximal end **1704** of the single lumen tubing member is coupled to another filter component **1022c** and pressure interface **1024c**. Pressure interface **1024c** contacts pressure transducer **1030** when the CCMG testing module is coupled to the control device, enabling pressure transducer **1030** to sense pressure within the third fluid conduit.

Use of the diagnostic system to perform a CCMG will now be described in detail with reference to FIGS. **18, 19** and **22**. First, the CCMG module is coupled to the control device (**2210**). The physical connection causes the identification probes **502** of the control device **102** to engage the identification elements **504** of the CCMG testing module, enabling the control device to identify the CCMG testing module. The physical coupling also brings pressure interfaces **1024b, 1024c** in contact with the pressure transducers **128, 1030** so that pressure changes in the second and third conduits can be detected by the pressure transducers. This coupling also causes the tubing loop **1012** to engage the pump device **118** so that the pump can drive fluid through the tubing in the CCMG module.

Once the CCMG testing module **1700** is coupled to the control device **102**, the operator enters input data appropriate for the CCMG test (**2215**). This data is received and interpreted by the microprocessor **710** and applicable informa-

tion is sent by the microprocessor to the display **110**. Priming operations are then performed (**2220**)

The dual lumen catheter **1422** is inserted into the bladder via the urethra **1302** (**2225**). The single lumen catheter **1702** is inserted into either the vagina or the rectum (**2230**) and the test is started (**2235**) by pressing the input pendant switches **124**. The microprocessor **710** receives the signal from the input pendant switches. This in turn sends instructions to the pump device **118** via the integrated circuit **702**, and the pump device pumps fluid through the first tubing conduit **1042** and tubing element **1418** into the bladder (**2240**). As fluid volume builds in the bladder, pressure in the bladder also builds. This pressure is transmitted through pressure interface **1024b** to pressure transducer **128**. Similarly, abdominal pressure is transmitted through pressure interface **1024c** to pressure transducer **1030**. The pressure transducers receive the pressure data and transcribe it into electrical signals. The electrical signals are sent to the microprocessor **710** via the integrated circuit board **702** where it is acquired and conditioned. The microprocessor ends the test after a specified amount of time or upon receipt of an "off" signal from input pendant switches **124** (**2245**). Once the test has been completed, the operator disengages the input pendant switches and removes the catheters **1422** and **1702** from the bladder (**2250**). The stored information is then available for review on the display screen, or by a print out through a charging cradle (printer assembly), or downloaded to a PC via a software interface in the charging cradle.

Referring again to FIGS. **8a-i**, the CCMG module software subroutine and graphical user interface is substantially as described in connection with the SCMG module. The system subtracts the abdominal pressure from the bladder pressure to calculate detrusor (bladder muscle) pressure. Detrusor pressure is then plotted against volume.

Both the SCMG and CCMG testing modules **1400** and **1700** provide a simple, relatively low cost procedure for recording a cystometrogram (CMG). The SCMG and CCMG testing modules are sterile, disposable assemblies that eliminate the need to disinfect equipment prior to use. This, together with a relatively simple set-up and operational procedure by the physician, greatly reduces the time required to obtain the urodynamic data. The SCMG and CCMG testing modules are more comfortable for the female patient and are more cost effective for the physician. The simplicity of the SCMG and CCMG testing modules, and the control device **102** allows operation with minimal training. Further, when combined in operational use with the SUI testing module **1000**, these modules provide a near complete urodynamic diagnostic tool for the physician.

#### Uroflometry

A uroflometry testing module **2400** can also be removably coupled to control device **102**. The module housing of the uroflometry testing module **2400** may be in the form of a plastic disposable cartridge. As shown in FIGS. **24** and **25**, the Uroflometry testing module **2400** includes a single lumen tubing member **2402** having a proximal end **2404** and a distal end **2406** and a channel extending substantially therethrough. A balloon **2408** or other suitable elastomeric element is coupled to the distal end **2406**, however, so that the channel of the single lumen tubing member is not open is at the distal end. A pressure cushion may also be used in place of the balloon. A collection bucket **2410** is positioned on top of the balloon. The inner surface of the collection bucket may also contain a urinalysis strip which, when

wetted by the voided urine, allows for quantitative assessment of standard urinalysis parameters

The diagnostic system including the Uroflometry testing module is operated as follows. The collection bucket is positioned under a commode **2412** to collect urine as the patient voids. Balloon is positioned relative to the bucket so that it substantially supports the bucket. As the bucket fills the pressure in the balloon rises proportionately to the weight of the fluid. When the testing module is coupled to the control device, the proximal end **2404** of the single lumen tubing member **2402** contacts the pressure transducer **128** of the control device **102** so that the pressure within the balloon can be captured and interpreted by the control device. The pressure data is used to calculate the weight and volume of the fluid (known fluid density). The stored information is then available for review on the display screen, or by a printout through a charging cradle (printer assembly), or downloaded to a PC via a software interface in the charging cradle. Once the test has been completed, the operator disengages the input pendant switches **124**, and the urine and collection bucket are discarded.

Operation of the Uroflometry module software subroutine is illustrated in FIGS. **8a-b**. Following module detection **802** and a command to execute the UroFlow Module Subroutine **804**, the UroFlow module subroutine begins. The operator is prompted to Enter UroFlow Patient Data **840** necessary for the UroFlow test routine. Once the patient data is collected a UroFlow Scale Zeroing Procedure **841** runs. The operator then enters information necessary to initiate the UroFlow test (UroFlow Test I/O) and the test is started **842**. Following the test the software then exits the UroFlow test subroutine and stores the data collected in the Data Storage routine.

#### Vaginal Speculum

FIGS. **26-28** illustrate a vaginal speculum assembly **2600** for use in the reduction of vaginal prolapse when performing female urodynamic testing, as previously discussed. Uterine or vaginal prolapse occurs when the uterus or pelvic organs drop or become displaced because of weakened pelvic muscles. Prolapse must be reduced to effectively perform urodynamic tests to ensure that no underlying stress urinary incontinence symptoms are masked by the pressure of the vaginal prolapse, which may cause distortion or kinking of the urethral canal. The vaginal speculum assembly **2600** will permit the clinician or physician to perform a urodynamic test procedure with one hand while still reducing vaginal prolapse, as well as properly position the meatus plug device or other catheter within the urethral canal. This prolapse maneuver using the vaginal speculum assembly **2600** during urodynamic testing is especially important prior to surgical repair of the vaginal prolapse, as an undiagnosed case of stress urinary incontinence may surface following prolapse surgery. The urodynamic testing being performed using the vaginal speculum assembly in this manner allows the surgeon to determine if additional stress urinary incontinence (SUI) surgery should be performed at the time of prolapse repair.

Current medical practice calls for the use of a vaginal speculum secured in place in order to reduce the prolapse. For example, U.S. Pat. Nos. 5,997,474 and 6,048,308 describe specula specifically designed for vaginal examination and treatment. U.S. Pat. No. 6,120,438 discloses a vaginal retractor device designed to hold back the vaginal wall during an exam or surgical procedure. Often, surgical tape is necessary to hold the speculum in place, as the physician's hands cannot hold the speculum in place while

performing a particular urodynamic procedure. None of the prior art speculum devices integrate the use of urodynamic equipment.

With reference to FIGS. **26** and **27**, the vaginal speculum assembly **2600** includes a connector member **2602** for coupling an insertion device assembly, such as a meatus plug device **1102**, or catheter **1422** and related elements to the vaginal speculum. The vaginal speculum can be of any type well known in the art. In the illustrated embodiment, the vaginal speculum includes an upper arm **2604**, a lower arm **2606**, and a hinge member **2608** for joining the upper and lower arms together. The vaginal speculum also includes a handled member **2610** being integrally attached, and preferably substantially perpendicular aligned to the lower arm. The vaginal speculum **2600** further includes a locking bar device **2612** connected to the upper arm **2606** for locking the upper and lower arms in an open position, as shown in FIG. **28**. The upper arm **2604** includes a posterior end **2614** with a pair of arm mounting openings **2616** therein. The connector member **2602** includes a flexible band **2618**. The flexible band at one end **2620** includes a pair of mounting openings **2622** and at the other end **2624** a connector element **2626**. The mounting openings **2622** of the flexible band **2618** are aligned with the arm mounting openings **2616** of the upper arm for receiving a pair of mounting screws **2628** therein in order to attach the connector member **2602** to the vaginal speculum **2600**. During use, the connector element can be coupled to the meatus plug device or catheter as shown in FIG. **26**.

Although a particular embodiment of the connector member **2602** is illustrated and described herein, those skilled in the art will recognize that various other embodiments are also possible to provide a means by which to removably couple a device that is inserted into the urethral canal to the speculum so as to hold it in place within the patient.

In operation, the vaginal speculum assembly **2600** can be cooperatively used in conjunction with the urodynamic system disclosed herein. For example, it may be used in conjunction with a urodynamic system including a SUI testing module **1000** in the performance of the urodynamic testing procedure for stress urinary incontinence (SUI), such as the measuring of urethral resistance pressure (URP) as previously described. In reference to FIG. **28**, the physician positions the vaginal speculum assembly **2600**, such that it is fully inserted within vaginal canal **2650** wherein the upper and lower arms **2604**, **2606** are fully opened and pressed against the vaginal walls **2650w** for reducing the patient's vaginal prolapse. The physician then locks the upper and lower arms of the vaginal speculum in the fully opened configuration (see FIG. **28**) via the locking bar device **2612**, and adjusts the connector member **2602** so that the insert member will be aligned with the urethral canal. The remaining operational steps are exactly the same as the operational steps described above in connection with individual testing modules.

Although the portable medical system disclosed herein has been described in conjunction with diagnostic testing, it is to be understood that the system can also be used in conjunction with therapies and/or surgical procedures for treating urinary incontinence, such as placement of a sling, placement of bulking agents, shrinkage of tissue etc. In this regard, the testing described herein can be used before, during and/or after these procedures to ensure success of the procedures, for example, to ensure correct placement and/or tensioning of a sling.

Although exemplary embodiments and methods for use have been described in detail above, those skilled in the art

## 21

will understand that many variations are possible without departing from the spirit and scope of the invention, which is limited only by the appended claims.

What is claimed is:

1. A method for diagnosing detrusor instability comprising the steps of:

using an insert member having a channel therethrough positioned distal of the urethral sphincter, creating a substantially fluid tight seal to substantially block fluid flow into or out of the urethral canal other than through the channel;

infusing fluid from a fluid source through the channel in the insert member and into the urethral canal at a location distal of the urethral sphincter;

measuring a pressure within the urethral canal at a location distal of the urethral sphincter as the fluid is being infused therein,

wherein the infusing step further includes infusing fluid until the urethral sphincter opens, and thereafter until at least one detrusor contraction occurs.

2. The method according to claim 1, wherein the fluid is infused at rate of approximately 40-120 mL/min.

3. The method according to claim 2, wherein fluid is infused for at least approximately 3 minutes.

4. The method according to claim 1, further comprising the steps of:

providing data correlating to the measured pressure to a processor; and

displaying on a display device measured pressure versus time.

5. The method according to claim 1, wherein at least a distal portion of the insert member is substantially conical in shape.

6. The method according to claim 5, wherein the insert member channel further comprises an insert member channel inlet at a proximal end and an insert member outlet at a distal end including a plurality of apertures spaced apart about an outer surface of the distal end of the insert member.

7. The method according to claim 1, wherein the insert member is coupled to a device for diagnosing urinary incontinence, the device including a control device having a processor and a pump therein, and a test module removably coupled to the control device, the test module including a tubing assembly coupled to the pump for pumping fluid therethrough, and having a first fluid conduit between a fluid inlet and a fluid outlet, the fluid outlet being coupled to the insert member and in fluid communication with the insert member channel.

8. The method according to claim 7, wherein the fluid inlet of the first fluid conduit is coupled to a fluid source.

9. The method according to claim 8, wherein the control device further includes a pressure sensor, and the test module further includes a pressure interface in fluid communication with the first fluid conduit and in communication with the pressure sensor so as to transmit pressure information thereto.

10. A method for diagnosing detrusor instability comprising the steps of:

coupling a test module to a control device, the test module including a tubing assembly having a first fluid conduit between a first fluid inlet and a first fluid outlet, and an insert member coupled to the first fluid outlet and having a channel therethrough in communication with the first fluid conduit so that fluid flowing through the first fluid conduit can flow through the insert member; coupling the first fluid inlet to a fluid source;

## 22

inserting the insert member at least partially into a patient's urethral canal at a location distal of the urethral sphincter so as to substantially block fluid flow into or out of the urethral canal other than through the insert member channel;

infusing fluid from the fluid source into the urethral canal through the first fluid conduit and insert member; and measuring the pressure within the urethral canal at a location distal of the urethral sphincter as the fluid is being infused therein,

wherein, the infusing step further includes infusing fluid into the urethral canal until the urethral sphincter opens, and thereafter until at least one detrusor muscle contraction occurs.

11. The method according to claim 10, wherein fluid is infused at a rate of approximately 40-120 mL/min.

12. The method according to claim 11, wherein fluid is infused for at least approximately 3 minutes.

13. The method according to claim 10, wherein the coupling step further comprises coupling the first fluid conduit with a pump device in the control device, and the infusing step further comprises activating the pump device to thereby cause fluid to be infused from the fluid source through the first fluid conduit and insert member channel.

14. The method according to claim 13, wherein the pump device is a peristaltic pump.

15. The method according to claim 10, wherein the test module further includes a pressure interface in fluid communication with the first fluid conduit, and the coupling step further comprises coupling the pressure interface with a pressure sensor in the control device so as to enable the pressure interface to transmit pressure information thereto.

16. A method for diagnosing detrusor instability comprising the steps of:

inserting an insert member having a channel therethrough at least partially into a patient's urethral canal at a location distal of the urethral sphincter, the insert member being dimensioned to substantially block fluid flow into and out of the urethral canal other than through the insert member channel;

infusing fluid from a fluid source through the insert member channel and into the urethral canal at a location distal of the patient's urethral sphincter at a rate of approximately 40-120 mL/min;

measuring pressure within the urethral canal at a location distal of the urethral sphincter as fluid is being infused therein; and

providing data correlating to the measured pressure to a processor;

wherein the infusing step further includes infusing fluid until the urethral sphincter opens, and thereafter until at least one detrusor contraction occurs.

17. The method according to claim 16, further comprising the step of displaying data correlating to the measured pressure versus time on a display device.

18. The method according to claim 16, wherein the insert member is coupled to a device for diagnosing urinary incontinence, the device including a control device having a processor and a pump therein, and a test module removably coupled to the control device, the test module including a tubing assembly coupled to the pump for pumping fluid therethrough, and having a first fluid conduit between a fluid inlet and a fluid outlet, the fluid outlet being coupled to the

**23**

insert member and in fluid communication with the insert member channel.

**19.** The method according to claim **18**, wherein the control device further includes a pressure sensor, and the test module further includes a pressure interface in fluid com-

**24**

munication with the first fluid conduit and in communication with the pressure sensor so as to transmit pressure information thereto.

\* \* \* \* \*