

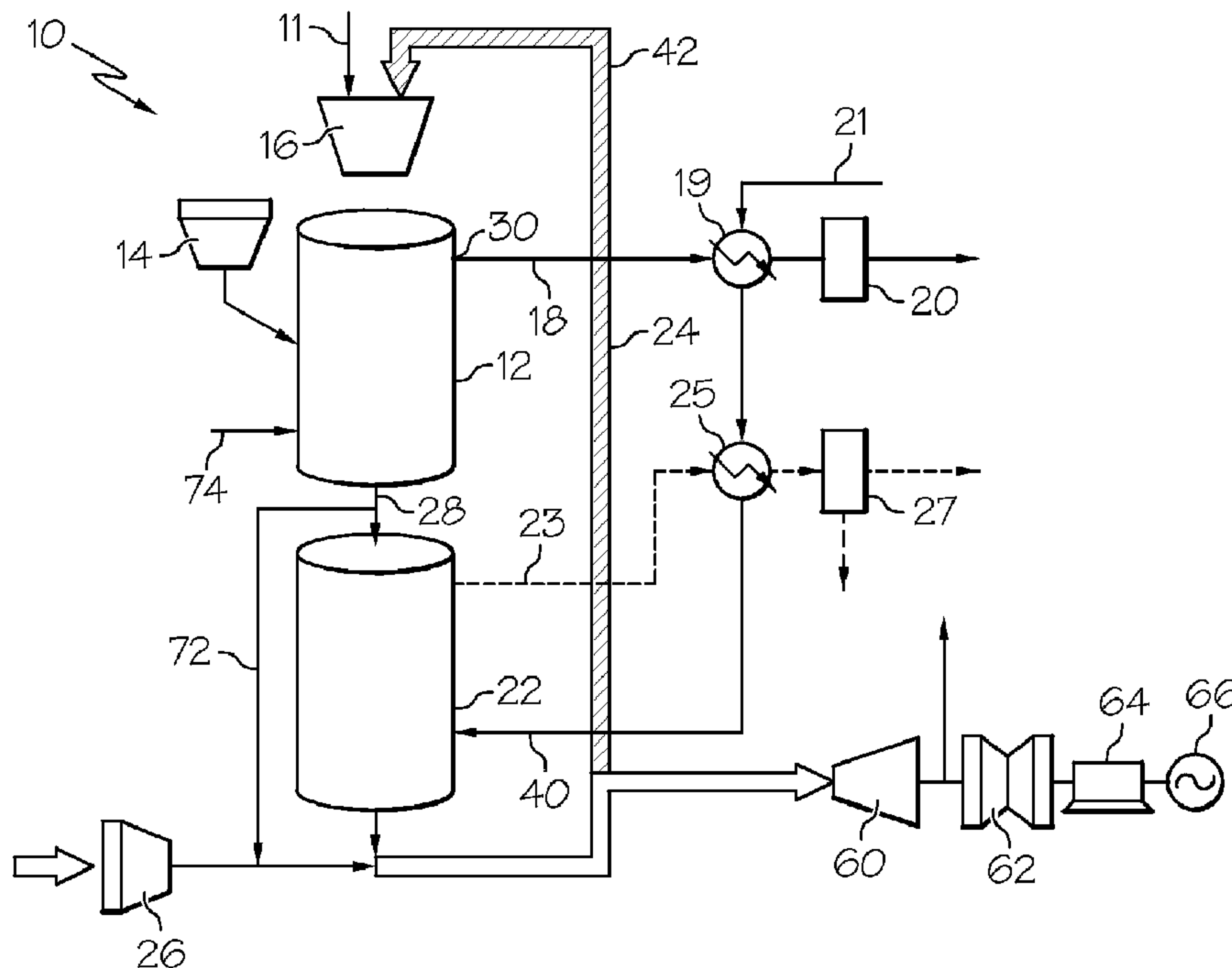

(86) **Date de dépôt PCT/PCT Filing Date:** 2009/09/28
 (87) **Date publication PCT/PCT Publication Date:** 2010/04/01
 (45) **Date de délivrance/Issue Date:** 2016/11/15
 (85) **Entrée phase nationale/National Entry:** 2011/03/21
 (86) **N° demande PCT/PCT Application No.:** US 2009/058579
 (87) **N° publication PCT/PCT Publication No.:** 2010/037011
 (30) **Priorité/Priority:** 2008/09/26 (US61/100,520)

(51) **Cl.Int./Int.Cl. F23C 13/02** (2006.01)
 (72) **Inventeurs/Inventors:**
 FAN, LIANG-SHIH, US;
 LI, FANXING, US
 (73) **Propriétaire/Owner:**
 THE OHIO STATE UNIVERSITY, US
 (74) **Agent:** GOWLING WLG (CANADA) LLP

(54) **Titre : TRANSFORMATION DES COMBUSTIBLES CARBONES EN VECTEURS ENERGETIQUES SANS CARBONE**
 (54) **Title: CONVERSION OF CARBONACEOUS FUELS INTO CARBON FREE ENERGY CARRIERS**



(57) **Abrégé/Abstract:**

A system for converting fuel is provided and includes a first reactor comprising a plurality of ceramic composite particles, the ceramic composite particles comprising at least one metal oxide disposed on a support, wherein the first reactor is configured to



(57) Abrégé(suite)/Abstract(continued):

reduce the at least one metal oxide with a fuel to produce a reduced metal or a reduced metal oxide; a second reactor configured to oxidize at least a portion of the reduced metal or reduced metal oxide from the said first reactor to produce a metal oxide intermediate; a source of air; and a third reactor communicating with said source of air and configured to regenerate the at least one metal oxide from the remaining portion of the solids discharged from the said first reactor and the solids discharged from the said second reactor by oxidizing the metal oxide intermediate.

(12) INTERNATIONAL APPLICATION PUBLISHED UNDER THE PATENT COOPERATION TREATY (PCT)

(19) World Intellectual Property Organization
International Bureau(43) International Publication Date
1 April 2010 (01.04.2010)(10) International Publication Number
WO 2010/037011 A3(51) International Patent Classification:
C10J 3/00 (2006.01)(21) International Application Number:
PCT/US2009/058579(22) International Filing Date:
28 September 2009 (28.09.2009)

(25) Filing Language: English

(26) Publication Language: English

(30) Priority Data:
61/100,520 26 September 2008 (26.09.2008) US(71) Applicant (for all designated States except US): **THE OHIO STATE UNIVERSITY** [US/US]; 1216 Kinnear Road, Columbus, OH 43212-1154 (US).

(72) Inventors; and

(75) Inventors/Applicants (for US only): **FAN, Liang-shih** [US/US]; 1216 Kinnear Road, Columbus, OH 43212-1154 (US). **LI, Fanxing** [CN/US]; 1216 Kinnear Road, Columbus, OH 43212-1154 (US).(74) Agent: **HAGAN, Timothy, W.**; Dinsmore & Shohl LLP, One South Main Street, One Dayton Centre, Suite 1300, Dayton, OH 45402-2023 (US).

(81) Designated States (unless otherwise indicated, for every kind of national protection available): AE, AG, AL, AM, AO, AT, AU, AZ, BA, BB, BG, BH, BR, BW, BY, BZ, CA, CH, CL, CN, CO, CR, CU, CZ, DE, DK, DM, DO, DZ, EC, EE, EG, ES, FI, GB, GD, GE, GH, GM, GT, HN, HR, HU, ID, IL, IN, IS, JP, KE, KG, KM, KN, KP, KR, KZ, LA, LC, LK, LR, LS, LT, LU, LY, MA, MD, ME, MG, MK, MN, MW, MX, MY, MZ, NA, NG, NI, NO, NZ, OM, PE, PG, PH, PL, PT, RO, RS, RU, SC, SD, SE, SG, SK, SL, SM, ST, SV, SY, TJ, TM, TN, TR, TT, TZ, UA, UG, US, UZ, VC, VN, ZA, ZM, ZW.

(84) Designated States (unless otherwise indicated, for every kind of regional protection available): ARIPO (BW, GH, GM, KE, LS, MW, MZ, NA, SD, SL, SZ, TZ, UG, ZM, ZW), Eurasian (AM, AZ, BY, KG, KZ, MD, RU, TJ, TM), European (AT, BE, BG, CH, CY, CZ, DE, DK, EE, ES, FI, FR, GB, GR, HR, HU, IE, IS, IT, LT, LU, LV, MC, MK, MT, NL, NO, PL, PT, RO, SE, SI, SK, SM, TR), OAPI (BF, BJ, CF, CG, CI, CM, GA, GN, GQ, GW, ML, MR, NE, SN, TD, TG).

Declarations under Rule 4.17:

- as to applicant's entitlement to apply for and be granted a patent (Rule 4.17(ii))
- as to the applicant's entitlement to claim the priority of the earlier application (Rule 4.17(iii))

[Continued on next page]

(54) Title: CONVERSION OF CARBONACEOUS FUELS INTO CARBON FREE ENERGY CARRIERS

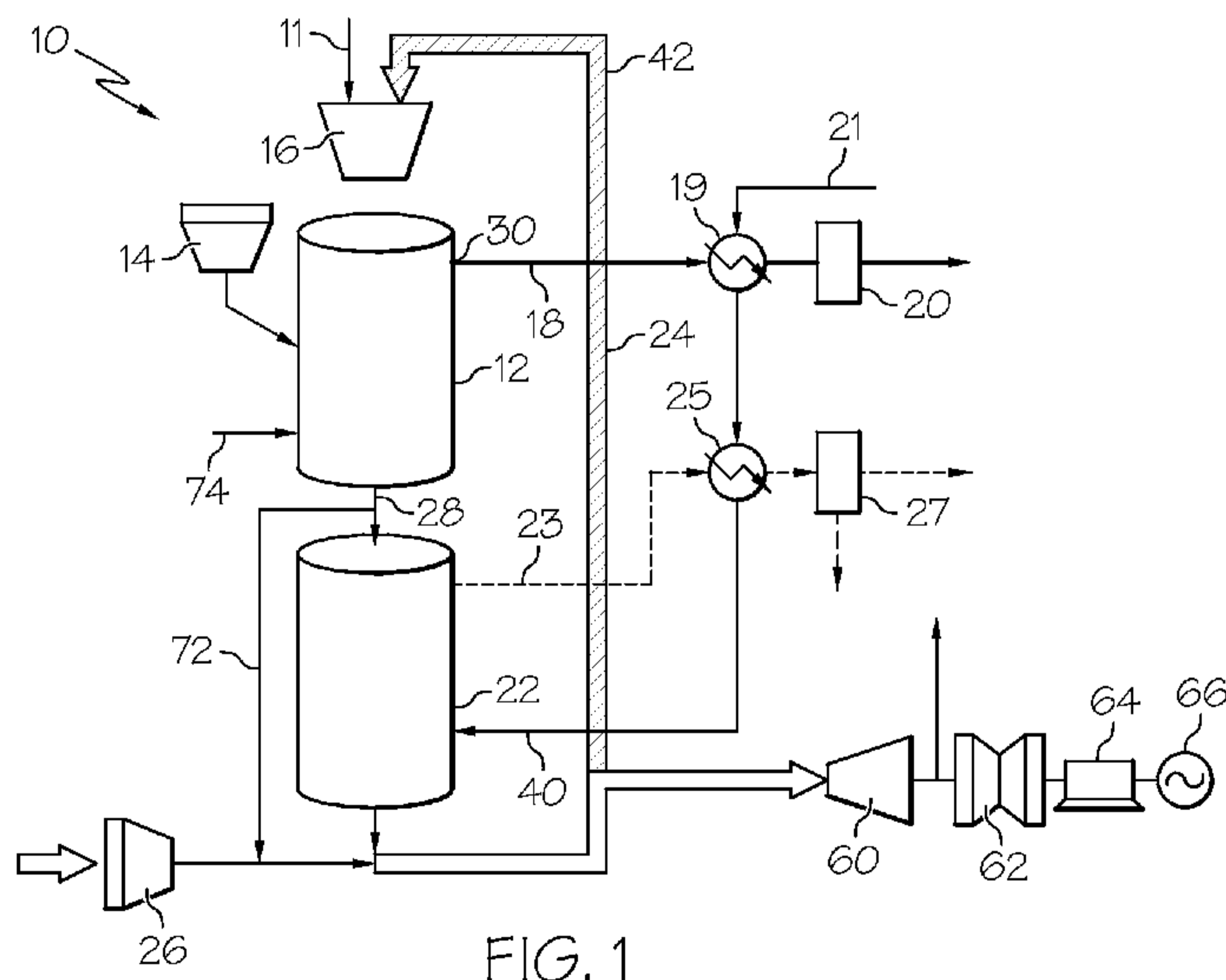

(57) Abstract: A system for converting fuel is provided and includes a first reactor comprising a plurality of ceramic composite particles, the ceramic composite particles comprising at least one metal oxide disposed on a support, wherein the first reactor is configured to reduce the at least one metal oxide with a fuel to produce a reduced metal or a reduced metal oxide; a second reactor configured to oxidize at least a portion of the reduced metal or reduced metal oxide from the said first reactor to produce a metal oxide intermediate; a source of air; and a third reactor communicating with said source of air and configured to regenerate the at least one metal oxide from the remaining portion of the solids discharged from the said first reactor and the solids discharged from the said second reactor by oxidizing the metal oxide intermediate.

WO 2010/037011 A3 

Published:

- *with international search report (Art. 21(3))*
- *before the expiration of the time limit for amending the claims and to be republished in the event of receipt of amendments (Rule 48.2(h))*

(88) Date of publication of the international search report:
23 September 2010

-1-

CONVERSION OF CARBONACEOUS FUELS INTO CARBON FREE ENERGY CARRIERS

5 The present invention is generally directed to systems and methods of converting carbonaceous fuels. Reduction-Oxidation (redox) reactions, with the presence of one or more chemical intermediates, are generally utilized to convert the carbonaceous fuels.

10 In order to meet the ever increasing demand for clean and affordable energy carriers and to ensure the sustainable growth of modern economy, efficient and environmentally friendly technologies that convert carbonaceous fuels such as coal, crude oil, natural gas, biomass, tar sands, and oil shale into carbon free energy carriers are highly desirable. An energy carrier is a substance or phenomenon that can be used to produce mechanical work or heat or to operate chemical or physical processes.

15 Existing carbonaceous fuel conversion technologies are either capital intensive (gasification or ultra-supercritical pulverized coal combustion), have low efficiencies (sub-critical pulverized coal combustion), or both, especially when CO₂ regulation is mandatory.

20 Chemical reactions between carbonaceous fuels and air/steam/CO₂ through the assistance of a metal oxide medium may represent an effective way to convert the fuels. A number of techniques have been proposed to convert carbonaceous fuels using metal oxide. For example, Watkins, U.S. Patent No. 3,027,238, describes a method for producing hydrogen gas including reducing a metal oxide in a reducing zone, and oxidizing the reduced metal with steam to produce hydrogen in an oxidizing zone. Thomas et al., U.S. Published Application No. 2005/0175533, and Fan et al., PCT Application No. WO 2007/082089, both describe methods for producing hydrogen gas by reducing a metal
25 oxide in a reduction reaction between a carbon-based fuel and a metal oxide to provide a reduced metal or metal oxide having a lower oxidation state, and oxidizing the reduced metal or metal oxide to produce hydrogen and a metal oxide having a higher oxidation state. The metal or metal oxide is provided in the form of a porous composite of a ceramic material containing the metal or metal oxide.

-2-

A well known process is a steam-iron process wherein coal-derived producer gas is reacted with iron oxide particles to be later regenerated with steam to produce hydrogen gas. However, a fluidized bed is used in this system which causes iron (Fe) to loop between FeO and Fe₃O₄, the gas is not fully converted, and no pure gas stream can be produced. Ishida et al., U.S. Patent No. 5,447,024, describes processes that make use of nickel oxide particles to convert natural gas through a chemical looping process into heat to be used in a turbine. However, this technology has limited applicability because it can only convert costly natural gas into heat/electricity. Therefore, both the feedstock and the product of the process are restricted.

10 With increasing demand for cleaner and more efficient energy carriers such as electricity, hydrogen, and fuels, the need arises for improved systems, and system components therein, which produce the aforementioned energy carriers with higher efficiency and lower emissions.

Embodiments of the present invention provide novel systems and processes for converting solid, liquid, and gaseous fuels into efficient energy carriers. In one embodiment, a system for converting solid, liquid, or gaseous fuel is provided and comprises a first reactor comprising a plurality of ceramic composite particles. The ceramic composite particles comprise at least one metal oxide disposed on a support, and the first reactor is configured to reduce the at least one metal oxide with a fuel to produce a reduced metal or a reduced metal oxide. The system includes a second reactor configured to at least partially re-oxidize the reduced metal or reduced metal oxide to produce a metal oxide intermediate. The system also includes a source of air and a third reactor communicating with the source of air and configured to regenerate the at least one metal oxide by oxidizing the metal oxide intermediate. In a preferred form, the fuel is a solid fuel or a gaseous fuel. Optionally, a fuel conversion enhancement gas, preferably including CO₂, steam, and/or H₂, is sent to the first reactor in which the gas flows countercurrently to the flow of solids.

-3-

Also provided is a method of preparing ceramic composite particles, for example in the form of pellets, comprising the steps of, mixing a metal oxide with at least one ceramic material to form a mixture, granulating the mixture, and drying the granulated mixture. The dried, granulated mixture is processed into particle form such that the characteristic length of the particles is greater than about 200 μm . The particles are heat treated at a temperature of from about 500 to about 1500°C and optionally may be reduced and oxidized prior to use in the reactor system.

Additional features and advantages provided by embodiments of the subject matter described herein will be more fully understood in view of the following detailed description, the accompanying drawings, and the appended claims.

The following detailed description of the illustrative embodiments of the subject matter described herein can be best understood when read in conjunction with the following drawings, where like structure is indicated with like reference numerals and in which:

Fig. 1 is a schematic illustration of one embodiment in which a system for producing hydrogen and/or electricity from coal and/or biomass without the need for an Air Separation Unit (ASU) is provided;

Fig. 2A is a schematic illustration of a reducer that converts coal and/or biomass into CO_2 and steam, while reducing Fe_2O_3 in the composite particles into Fe and FeO; Figs. 2B and 2C illustrate an alternative design for solid fuel injection and reactor outlet ports in the reducer;

Fig. 3 is a schematic illustration of a coal char/biomass conversion enhancement scheme;

Figs. 4A and 4B are schematic illustrations of gas solid flow patterns in the first and second stages of a reducer;

-4-

Fig. 5 is a chart showing the conversion of coal and an oxygen carrier in an embodiment of a moving bed reducer;

Fig. 6 is a schematic illustration of an alternative embodiment for a system that converts carbonaceous fuels into hydrogen, sequestrable CO₂, and heat;

5 Fig. 7 illustrates a heat integration scheme for an embodiment of a carbonaceous fuel conversion system;

Fig. 8 is a schematic illustration of a system that converts gaseous fuels such as syngas, methane, and other hydrocarbons, into hydrogen and/or electricity;

10 Fig. 9 is a chart showing the conversion of syngas and iron oxide in a moving bed reducer;

Fig. 10 is a chart showing the conversion of methane and iron oxide in a moving bed reducer;

Fig. 11 is a chart showing the concentration of hydrogen produced from a moving bed oxidizer;

15 Fig. 12 is a chart showing the crushing strength of an Fe₂O₃-based metal oxide composite particle made in accordance with an embodiment of the present invention;

Fig. 13 is a chart showing the attrition rate of oxygen carrier particles after a number of redox cycles;

20 Fig. 14 is a chart showing the reduction-oxidation rates of the oxygen carrier particles with respect to number of redox cycles;

Fig. 15 is a chart showing the reactivity of the oxygen carrier particle after reacting with coal for four reduction-oxidation cycles, syngas for three reduction-oxidation cycles, and natural gas for one reduction-oxidation cycle;

-5-

Fig. 16 is a graph illustrating the desired operating line of one embodiment of the reducer.

Fig.17 is a schematic illustration of an embodiment for electricity generation from biomass;

5 Fig. 18 is a schematic illustration of an embodiment for hydrogen/electricity generation from natural gas or other methane rich gas;

Fig. 19 is a schematic illustration of a design for the redox system using non-mechanical gas seals and solids flow control device; and

10 Fig. 20 illustrates alternative designs for non-mechanical gas sealing and solids flow control.

Referring generally to Figs. 1 and 8, embodiments of the subject matter described herein are directed to systems and methods for converting carbonaceous fuels by the redox reaction of metal oxide ceramic composites into carbon-free energy carriers such as hydrogen, heat, and electricity. Fig. 1 illustrates one embodiment of a system
15 configuration when solid carbonaceous fuels are used directly as the feedstock, while Fig. 8 illustrates one embodiment of a system configuration when gaseous carbonaceous fuels are used as the feedstock.

In the embodiment illustrated in Fig. 1, system 10 includes a first reactor 12, also termed the reducer herein, which is configured to oxidize solid carbonaceous fuel
20 from fuel source 14 into CO₂ and steam while reducing the metal oxide based ceramic composite particles which act as the oxygen carrier in the system. The solid fuel may be supplied by entraining it a flow of gas such as an oxygen-containing gas. As shown, a supply of metal oxide composite particles is stored in vessel 16 and supplied to reducer 12 as needed. Additional composite particles may be added as needed via conduit 11 as
25 shown in Fig. 1. The heat required or generated in reducer 12 is provided or removed, at least partially, by the metal oxide oxygen carrier particles. The combustion products of the fuel, CO₂ and steam, are removed from reducer 12 through line 18. As shown, the

-6-

steam is condensed by passing the gaseous stream through a heat exchanger 19 which is fed with a coolant such as water from line 21. The CO₂ stream, after optional removal of contaminants such as mercury in separator 20, is sent for sequestration. Typically, a relatively pure (i.e., >95%) CO₂ stream is produced from the reducer 12.

5 The second reactor 22, also termed the oxidizer herein, is configured to (partially) oxidize a portion or all of the reduced metal oxide oxygen carrier particles with either steam and/or CO₂ and to produce a stream of substantially pure hydrogen. The hydrogen is removed from oxidizer 22 through line 23. As shown, the hot hydrogen stream may be used to heat incoming steam in line 40 using heat exchanger 25. Any
10 contaminants, such as hydrogen sulfide gas, in the hydrogen stream may be removed through separator 27. The hydrogen gas may be used, for example, for electric power generation, liquid fuel synthesis, or other uses.. The third reactor 24, also termed the combustor herein, combusts the partially oxidized metal oxide oxygen carrier particles from oxidizer 22 and the remaining reduced metal oxide oxygen carrier particles from
15 reducer 12 using an oxygen containing gas such as air supplied, for example, via line 26 through optional compressor 28. In the case when reducer 12 requires additional heat, at least part of the heat generated from combustor 24 is integrated to the reducer. In some cases, an air separation unit (not shown) can be used to separate oxygen from air and send the oxygen into the reducer to partially combust the fuel and to provide additional heat to
20 the reducer 12. However, the capacity of such an air separation unit is much smaller than that used in a conventional gasification plant with identical fuel processing capacity. Therefore, one advantage of the system and process illustrated in Fig. 1 is that it can reduce the size of the air separation unit or eliminate the need for the air separation unit which separates oxygen from air. This reduces the capital cost of building and operating
25 the fuel conversion system and enhances the overall efficiency of the system. In preferred embodiments, the air separation unit is completely avoided. Although the system illustrated in Fig. 1 depicts solid fuel conversion, gaseous fuel and liquid fuel can also be converted using this system. The operating pressure in the combustor 24 can either be comparable to the pressures in the reducer and oxidizer, or may be different. In the former
30 case, non-mechanical based solids and gas flow control devices can be conveniently used

-7-

to connect the reactors. In the latter case, mechanical valves should be used. However, the combustor can be operated at lower pressures, resulting in reduced combustor energy consumption. Moreover, heat can be extracted from the solids discharged from the reducer so that the oxidizer is operated at temperatures significantly lower than those of the reducer. By doing this, the steam to hydrogen conversion is enhanced.

As shown in Fig. 1, hot spent air from combustor 24 can be optionally sent to an expander 60 coupled to a turbine 62 and a generator 64 and used to generate electricity 66.. Exhaust gas from the expander may be sent to separation equipment for the removal of contaminants such as sulfur oxides and nitrogen oxides.

Additional heat can be produced by means of: i) introducing a smaller fraction of the reduced metal oxide oxygen carrier particles from reducer 12 into oxidizer 14, with the remaining reduced metal oxide oxygen carrier particles being directly introduced to combustor 24; or ii) introducing a sub-stoichiometric amount of steam and/or CO₂ to oxidizer 22 so that the reduced metal oxide oxygen carrier particles are incompletely regenerated by the steam and/or CO₂.

The oxygen carrier comprises a plurality of ceramic composite particles having at least one metal oxide disposed on a ceramic support. Suitable ceramic composite particles for use in the system and process of the invention are described in Thomas U.S. Published Application No. 2005/0175533, and Fan et al., PCT Application No. WO 2007/082089. In addition to the particles and particle formula and synthesis methods described in Thomas, in a further embodiment described below, methods to improve the performance and strength of the ceramic composite particles have been developed.

The further embodiment includes the step of mixing a metal oxide with at least one ceramic support material in powder form followed by an optional granulation step with the addition of either water or a binding material such as starch, sodium silicate, and/or potassium silicate. A promoter material may be added in the mixing step before granulation. The granulated powder is then dried at temperatures of between about 50° - 500°C in air or nitrogen to reduce the moisture content to below 10%. The granulated

-8-

powder is then processed into pellets with a characteristic length larger than about 200 μm . The methods for converting granulated powders into pellets may include, but are not limited to, extrusion, granulation, and pressurization methods such as pelletization. The pressure used to produce the pellets ranges from about 0.1 – 25 MPa.

5 After the metal oxide containing ceramic composite particles are made, final treatment steps are carried out. The final treatment steps include sintering the particles at 500° - 1500°C, followed by reducing the metal oxide in the particles with hydrogen and then oxidizing the particles with air for at least one reduction-oxidation cycle to stabilize the performance of the particles. It should be noted that spent powders resulting from
10 attrition in the reactor system can be reprocessed and reactivated following this method.

The metal oxide component preferably comprises a metal selected from the group consisting of Fe, Cu, Ni, Sn, Co, Mn, In, and combinations thereof. The support material comprises at least one component selected from the group consisting of SiC, oxides of Al, Zr, Ti, Y, Si, La, Sr, Ba, and combinations thereof. These supports include
15 naturally ores such as bentonite and sepiolite. The ceramic composite comprises at least about 10% by weight of the support material. In further embodiments, the particle comprises a promoter material. The promoter comprises a pure metal, a metal oxide, a metal sulfide, or combinations thereof. These metal based compounds comprise one or more elements from the group consisting of Li, Na, K, Rb, Cs, Be, Mg, Ca, Sr, Ba, , B, P,
20 V, Cr, Mn, Co, Cu, Zn, Ga, Mo, Rh, Pt, Pd, Ag, and Ru. The ceramic composite comprises up to about 20% by weight of the promoter material. In an exemplary embodiment of the ceramic composite, the metal oxide comprises Fe_2O_3 supported on a support which is a mixture of alumina (Al_2O_3) and Anatase (TiO_2).

Referring back to the reduction reaction taking place in reducer 12, the reducer
25 utilizes solid carbonaceous fuel such as coal, tars, biomass, oil shale, oil sands, tar sand, wax, coke, and the like to reduce the least one metal oxide of the ceramic composite particles to produce a mixture of reduced metal and/or metal oxide. The fuel is preferably supplied in particulate form to the reducer. The possible reduction reactions include but not limit to:

-9-

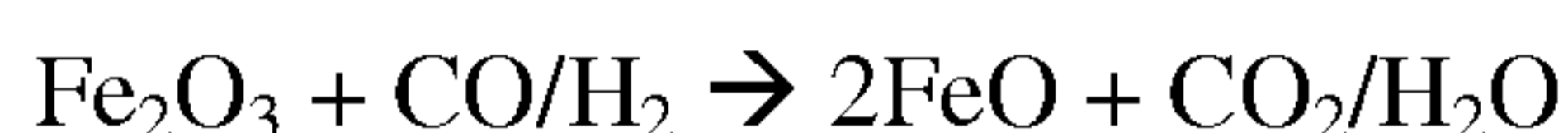
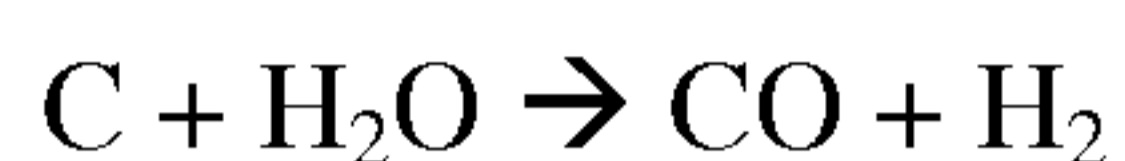
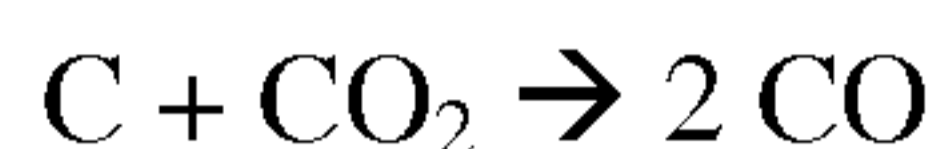
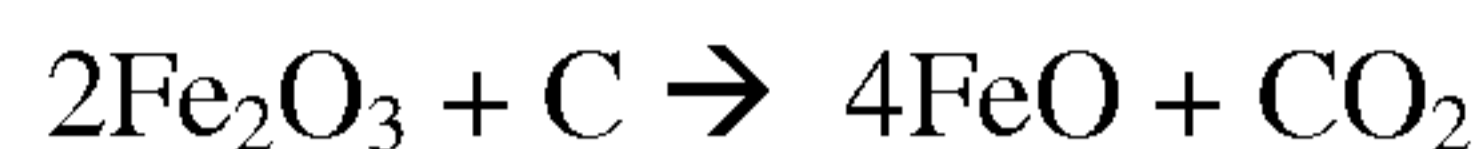

Preferred designs of the reducer include a moving bed reactor with one or more stages, a multistage fluidized bed reactor, a step reactor, a rotary kiln, or any other suitable reactor or vessel known to those skilled in the art. In any of the reactor designs, a counter-current flow pattern between the metal oxide oxygen carrier solid particles and the gas is used to enhance the gas and solid conversion. The counter-current flow pattern minimizes the back-mixing of both the metal oxide composite oxygen carrier solids and gas. Moreover, the counter-current flow maintains the solids outlet 28 of the reducer 12 in a more reductive environment, while the gas outlet 30 of reducer 12 is maintained in a more oxidative environment. As a result, the gas and solid conversion are both enhanced based on thermodynamic principles.

Fig. 16 exemplifies a preferred operating line of a reducer using syngas as the feedstock based on thermodynamic analysis. The preferred operating line (solid straight line) corresponds to full conversion (> 99% conversion) of gaseous syngas fuel into CO₂ and steam while reducing the oxygen carrier particles, such as iron oxide containing composite particles, by nearly 50%. Similarly, a preferred operating mode when a solid fuel such as coal is used will lead to full conversion (> 99% conversion) of coal into CO₂ and steam while reducing the iron oxide oxygen carrier composite particles by 33 – 85% depending on the ranking of the coal. Generally speaking, the operating conditions in the reducer are configured so that at least 95% of the carbonaceous fuel is converted to a gas stream with high CO₂ and steam concentration while reducing the iron oxide in the composite particles by 33% - 85%. The preferred iron oxide reduction rate is about 36 –

-10-

85%. Preferably, the reduced iron oxide should have a metallic iron to Wuestite molar ratio of between about 1:25 to 3.55:1.

The conversion of carbonaceous fuel is defined as:

$$X_{gas} = n_{o_consumed} / n_{o_fullconversion}$$

5 $n_{o_consumed}$ refers to number of moles of oxygen transferred to the fuel from the oxygen carrier in the reducer; $n_{o_fullconversion}$ represents number of moles of oxygen required to convert the fuel fully into CO₂ and steam.

The conversion of iron oxide (or any type of metal oxide described above) is defined as:

$$y = \frac{\hat{n}_O / \hat{n}_{Fe} - n_O / n_{Fe}}{n_O / n_{Fe}} \times 100\%$$

10

Here, n_O / n_{Fe} corresponds to the molar ratio between the oxygen and iron atoms in Fe₂O₃, while \hat{n}_O / \hat{n}_{Fe} corresponds to the molar ratio between the oxygen and iron atoms in the reduced solid product, i.e. FeO_x (0 < x < 1.5). For example, the reduction of Fe₂O₃ to Fe₃O₄ corresponds to a solid conversion of (3/2-4/3)/(3/2)×100% = 11.11%, FeO
15 corresponds to a conversion of 33.33%, and Fe corresponds to 100% solid conversion. Definition of the conversion of other metal oxides follows a similar definition. A similar definition applies when other metals are used.

Fig. 2 illustrates a specific embodiment of a reducer 12 configured for solid carbonaceous fuel conversion. A two stage moving bed is provided. The upper stage 32
20 (first stage) converts the gaseous phase from the lower stage 34 (second stage) and volatiles from the solid fuel into CO₂ and steam, while the lower stage 34 converts the solid fuel such as pulverized (i.e., particulate) coal, coke biomass, or coal char which is fed into the reducer from line 14. The metal oxide particles which enter the first stage through line 70 as, for example, Fe₂O₃-containing particles, exit the second stage as a
25 mixture of reduced metal (e.g., Fe) and metal oxide (e.g., FeO) through line 28 . An

-11-

oxygen-containing gas and, optionally a combustion enhancing gas such as CO₂, H₂O, or H₂, is fed into the bottom of the second stage through line 74; the hot combustion gases, CO₂ and steam, exit the top of the first stage through line 18. For example, when Fe₂O₃-containing particles are used as the oxygen carrier, the Fe₂O₃ conversion is between 20% - 5 85%. The two stage design of the reducer allows good mixing of both solid-solid and solid-gas. Moreover, the solids movement can be achieved with ease. In certain embodiments, a portion of the pulverized solid fuel is entrained by the gaseous phase in the reducer. As a result, a portion of the solid fuel moves upwardly and is combusted in both the first and second stages. Thus, the height of the second reactor stage can either be 10 significantly shorter or longer than the height of the first reactor stage depending on the physical and chemical properties of the fuel and the operating conditions in the reactor. Because of the flexibility in the reactor design, the point of injection of the solid fuel may be varied to any position between the reducer inlet and the reducer outlet.

In certain embodiments, pulverized solid fuel, which is injected through line 14 15 into the reducer between the first and second reducer stages 32 and 34, is entrained by the gaseous phase in the reducer and flows counter-currently against the metal oxide oxygen carrier particulate solids. The solid fuels are converted to CO₂ and steam during the entrainment step. At least 95% of the fuel will be converted before exiting from the top of the first stage of the reducer 12. A portion of the ash can also be entrained and removed 20 from the top of the first stage of the reducer. As shown in Figs. 2B and 2C, the pulverized solid fuel may be injected into the reactor at multiple locations to better distribute the fuel in the reactor.

The reactions that take place in the first and second stages of reducer 12 include:

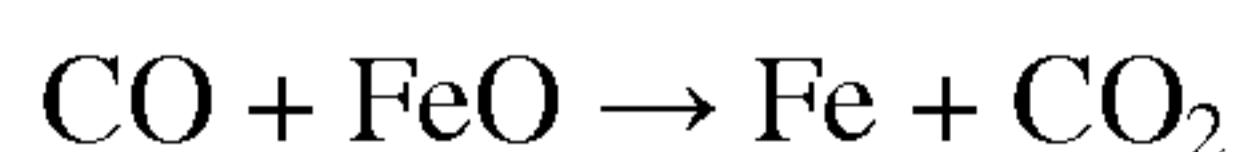

-12-

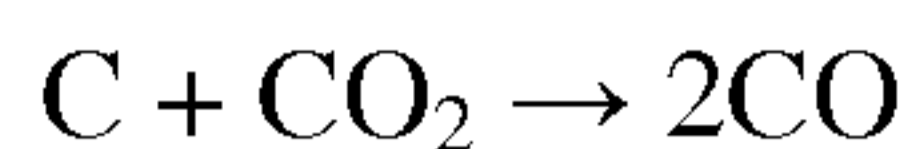

Char gasification and particle reduction:

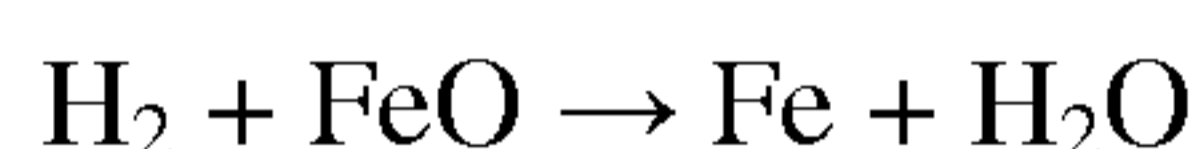
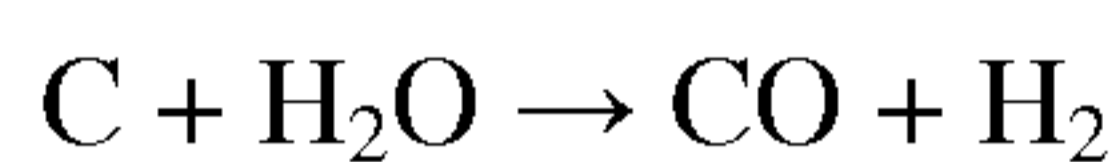
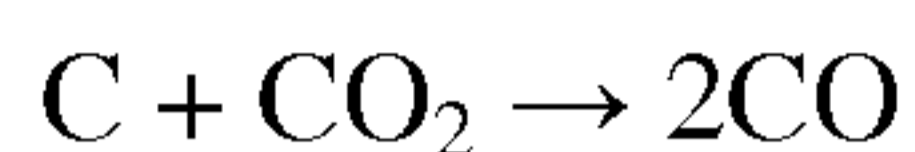

One of the issues related to conversion of solid fuel is the enhancement of solid fuel conversion. Fig. 3 illustrates a scheme to enhance the solid conversion by adding CO₂ to the bottom of the second reducer stage in Fig. 2. The addition of CO₂ initiates a “chain reaction” that gasifies carbon while reducing metal oxide. During this process, more CO₂, which acts as gasification enhancer, will be produced, resulting in further improved reaction rates. Other gasification enhancers include H₂O and H₂. It should be noted that although injection of CO₂ and H₂O may affect slightly the metal oxide conversion, they are still considered as feasible gasification enhancers since they are easily available in the fuel conversion system. One way to obtain such enhancers is to recycle part of the exhaust gas from the first stage of the reducer, which contains both CO₂ and steam, into the second reducer stage solids outlet (bottom). The aforementioned fuel conversion enhancement technique can also be applied for the conversion of gaseous/liquid carbonaceous fuels such as methane and higher hydrocarbons since CO and H₂ react with metal oxide faster than hydrocarbon or solid fuels.

Fig. 4 further illustrates a preferred design of the solids outlet (bottom) of the first stage of the reducer as well as the solids outlet (bottom) of the second stage of the reducer. The first stage has a restricted flow outlet such as, for example, a funnel shaped outlet 36 with multiple blades 38 on the interior wall. Such a design allows gas to permeate from the top of the second stage to the first stage. Meanwhile, the metal oxide based ceramic composite particles will be discharged from outlet 36 in a controlled

-13-

manner. A dune of solid particles is formed between the bottom of the first stage and the top of the second stage. Solid fuel is dispersed to the annular region 40 of the first stage and mixes well with the metal oxide based ceramic composite particles. The solids outlet 42 of the second stage also uses a restricted flow design such as a funnel shape. The funnel preferably has an angle of about 15 – 75°. Such an angle allows solids with different sizes to move downwardly at similar speeds, thereby avoiding small solids exiting the reducer at rates much faster than the larger solids. Moreover, the solids will act as a gas distributor to ensure good mixing between solid and gas. In certain embodiments, multiple funnel shaped solids outlets can be used, especially for the first stage outlet. Fig. 2, especially Figs. 2B and 2C, illustrates one example of an outlet design in which three funnel shaped outlets 36a, 36b, and 36c are used with three solid fuel injection ports 14a, 14b, and 14c. This design provides a more homogenous solids distribution in the reactor. Other configurations of funnel shaped outlets and solid fuel injection ports can also be used.

The effective regulation of gas and solids flows between the reactors is important. Mechanical valves such as rotary valve or a ball valve-table feeder system can be used to control the solids and gas movements. Non-mechanical valves, loop seals, and/or zone seals can also be used to regulate the gas and solids flow. Several suitable non-mechanical gas sealing and solids flow control devices are schematically illustrated in Fig. 20. These devices can be installed between reactors or reactor stages to control the flow of materials between stages.

Fig. 5 further illustrates in chart form the conversion of an iron oxide based particulate oxygen carrier and coal obtained in a moving bed reducer. More detailed results are listed in Table 1 below.

Table 1 Summary of the Fuel Reactor demonstration results using coal, coal char, and volatile

Type of Fuel	Coal Volatile	Lignite Char	Bituminous Char	Anthracite Coal
Fuel Conversion (%)	99.8	94.9 – 99.5	90.5	95.5
CO ₂ Concentration in Exhaust (% Dry Basis)	98.8	99.23	99.8	97.3
Gasification Enhancer	H ₂ /CO ₂	CO ₂ /H ₂ O	CO ₂	CO ₂

-14-

Generally speaking, solid fuel conversion of >90% with about 33% - 85% metal oxide conversion can be obtained. The exhaust gas stream from the reducer has > 95% CO₂ after condensing out steam.

Referring now to Fig. 17, where like reference numerals represent like elements, an embodiment for electricity generation from biomass is shown in schematic form. The configuration is similar to that shown in Fig. 1. In this embodiment, all of the reduced metal oxide particles are directly sent to the combustor 24. As a result, the oxidizer (not shown) is completely bypassed. A preferred configuration for the reducer of this embodiment is shown in Fig. 2. The hot gas stream generated from the system can be either used in a boiler/Heat Recovery Steam Generator (HRSG) or in a combined cycle system with an expander/gas turbine for power generation. Similarly, the combustor hot gas in the embodiment shown in Fig. 1 can also be used in a boiler/HRSG, although an expander is shown in Fig. 1 for illustrative purposes. The metals that can be used in the process shown in Fig. 1 include Fe, Ni, Cu, and Mn. When Fe₂O₃ is used, the preferred solid reduction rate is 11% - 75% for power generation purposes. Table 2 shows the experimental result obtained from biomass gasification:

Table 2. Experimental results obtained from pulverized woody biomass using Fe₂O₃ based ceramic composite and gasification enhancer (CO₂ and H₂O)

CO ₂ Concentration in the Reducer Exhaust (% dry basis)	Biomass Conversion (%)	Residence Time (Min)	Metal Oxide Reduction (%)
> 95%	> 99%	20 - 120	> 20%

In some cases the solid fuel may contain impurities such as ash, sulfur, and mercury. Ash in the solid fuel will exit the reducer along with the metal oxide based ceramic composite. Part of the sulfur will also exit the reducer in the form of metal-sulfur compounds such as FeS (Fe_{0.877}S) at high temperatures. The remainder of the sulfur exits the reducer in the form of H₂S/SO₂. The sulfur can be sequestered along with CO₂

-15-

without the need for treatment. All the mercury will also exit the reducer along with exhaust gas stream. The mercury can either be removed using known techniques or be sequestered.

Referring back to Fig. 1, a portion of the solids exiting reducer 12 will enter
5 second reactor 22 (the oxidizer). Preferred designs of the oxidizer include a moving bed reactor, a multistage fluidized bed reactor, a step reactor, a rotary kiln, or any other suitable reactor or vessel known to those skilled in the art. In any of the reactor designs, a counter-current flow pattern between oxygen carrier solid particles and gas is used to enhance the gas and solid conversion. The counter-current flow pattern minimizes the
10 back-mixing of both oxygen carrier solid and gas. Moreover, the counter-current flow keeps the solids outlet of reactor 22 in a more oxidative environment while the gas outlet of reactor 22 is maintained in a more reductive environment. As a result, the gas and solid conversion are both enhanced.

The connections between the reducer 12, oxidizer 22, and combustor 24 can be
15 mechanical, i.e. a rotary valve or a lock hopper assembly. In another design, the reducer 12, oxidizer 22, and combustor 24 are directly connected using non-mechanical valves and gas seals such as those used in a circulating fluidized bed or a fluid catalytic cracker. The pressure differences in the reactor as well as a small amount of aeration gas prevent the leakage of the product gas from the oxidizer 22 into the reducer 12 or vice versa. Such a
20 non-mechanical reactor design is illustrated in Fig. 19. Only one of the three connections ("A", "B", and "C" in Fig. 19) is used to control the overall solids circulation rate in the reactor system. Preferably, the connection between the oxidizer 22 and the combustor 24 (connection "C" in Fig. 19) is used to regulate the solids flow. Suitable non-mechanical valves for this connection between reactor stages include L-valves, J-valves, loop seals, or
25 N-valves. Aeration gas used here can be steam and/or spent air. For the connection between the combustor 24 and reducer 12 (connection "A" in Fig. 19), a zone seal or loop seal can be used with CO₂ and/or spent air as the aeration gas. For the connection between the reducer 12 and oxidizer 22 (connection "B" in Fig. 19), a zone seal or loop seal can be used with H₂ and/or steam as the aeration gas. Preferred designs for the non-

-16-

mechanical gas seal and solids valves are shown in Figs. 20A (N-valve), 20B (L-valve), 20C (loop seal), and 20D (standpipe and zone seal). Relatively smooth, funnel shaped reactor outlets are installed for both the reducer 12 and oxidizer 22 to ensure a smooth connection between the reactor (with large inner diameter) and the non-mechanical devices (with much smaller inner diameters). This reduces the usage of aeration gases. A particulate separation device (not shown) may also be installed between the combustor 24 and reducer 12. The device is used to separate out the fines from the combustor exhaust gas. A preferred separation device has more than a two stages. The first stage separates out larger particulates (e.g., 20 – 200+ μm) from the fine powder and exhaust gas. The second stage separates out smaller fines from the exhaust gas. The fines may be reprocessed into larger particles/pellets.

The gaseous feedstock for oxidizer 22 can either be steam, CO_2 , or a combination thereof and enters through line 40. When steam is used, the steam conversion of the oxidizer can be between about 50 – 99% depending on the oxidizer temperature and solid conversion in the reducer. When Fe_2O_3 based ceramic composite particles are used, an iron phase of at least 5% (by mole) is preferred in order to achieve optimum steam conversion. When CO_2 is used, the gas conversion (40 – 95%) is also dependant upon the temperature and solid conversion. When a mixture of CO_2 and steam is used, the oxidizer product stream can be condensed and partially recycled to reduce the CO_2 concentration in the final product stream and to improve the gas conversion.

The metal-sulfur compounds formed in reducer 12 will be partially regenerated in oxidizer 22, producing H_2S . Therefore, the product stream of the oxidizer is often contaminated with H_2S up to 750 ppm. H_2S can be removed via sorbent techniques, solvent techniques, or other traditional acid removal techniques. The ash in the metal oxide ceramic composite will not react in the oxidizer and will be discharged along with the partially regenerated metal oxide ceramic composite. When Fe_2O_3 based ceramic composite is used, the iron phase in the solid product from the oxidizer is predominantly Fe_3O_4 with some remaining metal-sulfur compounds. In certain embodiments, a sub-stoichiometric amount of steam/ CO_2 is introduced to regenerate the reduced iron oxide to

-17-

an oxidation state lower than Fe_3O_4 , e.g. Fe/FeO mixture, FeO, or FeO/ Fe_3O_4 mixture. By doing this, the heat that can be generated from the subsequent combustor will increase at the expense of reduced hydrogen/CO production in the oxidizer.

Referring back to Fig. 1, the partially regenerated metal oxide ceramic composite particles from the oxidizer are introduced to the third reactor 24 (the combustor) along with a portion of the reduced ceramic composite particles from the reducer 12. Preferred designs of the combustor 24 include a fast fluidized bed reactor, an entrained bed reactor, a transport bed reactor, or a mechanical conveying system. Optionally, to provide sufficient time for metal oxide ceramic composite regeneration, a two stage design may be adopted for the third reactor 24. With such a design, stage I of the third reactor, which is located at the bottom portion, is operated in a bubbling or turbulent fluidization regime to provide adequate solids and gas residence time. The diameter of stage I is typically larger than stage II when such a design is used.

The combustor 24 is used to substantially completely oxidize the metal oxide based ceramic composite back to its higher oxidation state. Air or other oxygen containing gas may be used in the combustor. The gaseous product from the combustor is an oxygen lean gas at a temperature much higher than the inlet gas temperature. The gaseous product may also contain SO_2 and NO_x . When Fe_2O_3 based ceramic composite is used, the iron phase in the solid product is predominantly Fe_2O_3 . Ash will also come out along with the fine ceramic composite powders resulting from attrition. A portion of the ash may exit from the gaseous outlet of the reducer.

A significant amount of heat is generated in the combustor 24. In one configuration, the heat is carried away from the combustor by both the gaseous product and solid product. The solid product is directly injected back to the reducer 12 through line 42. As a result, the sensible heat carried in the solid product is used to compensate the heat required in the reducer 12. Moreover, the sensible heat contained in the exhaust gas can also be transferred to the reducer via heat exchange.

-18-

Ash and spent ceramic composite can be separated using mechanical methods such as a cyclone. Ash separation efficiency was demonstrated to be at least 75.8% with 15 seconds of mechanical separation, which corresponds to less than 1% ash content in the ceramic composite when bituminous coal is used as the solid fuel.

<i>Before Experiment</i>			
Pellet (g)		Ash (g)	
2565.3		224.97681	
<i>After Experiment</i>			
Pellet (>2.8 mm)		Particle (<2.8mm)	
Pellet (g)	Ash (g)	Particle (g)	Ash (g)
2444.2	54.4	121.1	170.5

5

Referring now to Fig. 6, Fig. 6 exemplifies an alternative configuration for a fuel conversion system. In this configuration, where like reference numerals represent like elements, the first reactor 12 integrates the function of both the reducer and the combustor (such as shown in the configuration in Fig. 1). The first reactor 12 has a shell side 13 and a tube side 15. Solid or gaseous carbonaceous fuel is introduced into shell side 13 through line 14, and ceramic composite particles, supplied from vessel 16, are converted (i.e., reduced) in the shell side as well. A portion of the reduced solids from the shell side is directly recycled back to the tube side through conduits 19 and combusted with air. The heat released in the combustion compensates for the heat required in the shell side. Moreover, the hot solids from the third reactor 24 (combustor) will also partially compensate for the heat required in the reducer 12. Steam and CO₂ are supplied to oxidizer 22 through port 40, while the hydrogen stream is removed through line 23. Ceramic composite particles with regenerated metal oxide are sent from combustor 24 back to vessel 16. The heat from those particles may be captured and used for steam or power generation (indicated by line 35. ash and spent particles are removed via line 37.

10

15

20

Referring now to Fig. 7, where like reference numerals indicate like elements, Fig. 7 illustrates a generalized heat integration scheme for the process. In such a scheme,

-19-

heat generated in the combustor 24 is used to: 1) compensate for the heat requirements in the reducer 12, and 2) generate electricity for parasitic energy consumption. The goal of the heat integration is to minimize the excessive heat generated in the system, thereby maximizing the energy conversion from the fuel to the product. As shown, the metal
5 oxide particles are reduced in reducer 12, with reduced particles sent via lines 94 and 96 to the oxidizer 22 and combustor 24. Oxidized particles 98 are sent from oxidizer 22 to combustor 24, while regenerated particles 92 are recycled back to reducer 12. The heat produced by the reactions, shown as arrows H, is used to supply any required heat to reducer 12 and for the production of steam or electric power (at 100).

10 Referring now to Fig. 8, where like reference numerals indicate like elements, Fig. 8 illustrates a generalized system that converts gaseous/liquid carbonaceous fuels. The liquid carbonaceous fuels may include gasoline, oil, petroleum, diesel, jet fuel, ethanol, and the like; and the gaseous carbonaceous fuels include syngas, methane, carbon
15 monoxide, hydrogen, gaseous hydrocarbon gases (C1-C6), hydrocarbon vapors, and the like.

In the embodiment illustrated in Fig. 8, gaseous fuel such as syngas fuel or methane is converted, and the system can be divided into two reactors: a hydrogen generation reactor 80 and a combustor 86. The hydrogen generation reactor can be further divided into two stages: a reducer stage 82 and an oxidizer stage 84. Each stage in the
20 hydrogen generation reactor can also be considered as a separate reactor.

Preferred designs of the hydrogen generation reactor include a moving bed reactor with one or more stages, a multistage fluidized bed reactor, a step reactor, a rotary kiln, or any suitable reactor or vessel known to those skilled in the art. In any of the reactor designs, a counter-current flow pattern between solid and gas is used to enhance
25 the gas and solid conversion. The counter-current flow pattern minimizes the back-mixing of both solid and gas. Moreover, it improves the conversions of the gas and the solid thermodynamically. The residence time for solids typically ranges from about 15 minutes to about 4 hours. The reducer residence time typically ranges from about 7.5 minutes to

-20-

about 2 hours, and the oxidizer residence time also typically ranges from about 7.5 minutes to about 2 hours.

In the reducer 82, gaseous fuel is introduced at or near the bottom of the reducer and then moves countercurrently relative to the ceramic composite particles.

5 When syngas is used as the fuel, the possible reactions include:

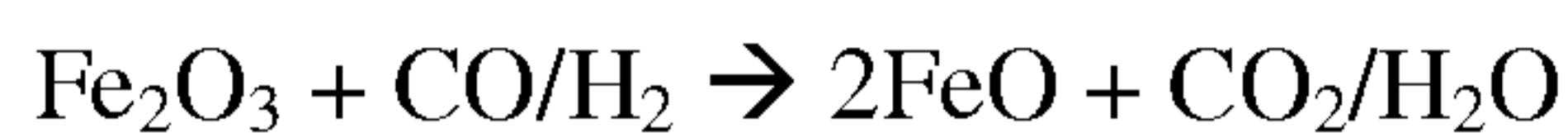

When natural gas or other methane rich gas is used as fuel, the possible reactions include:

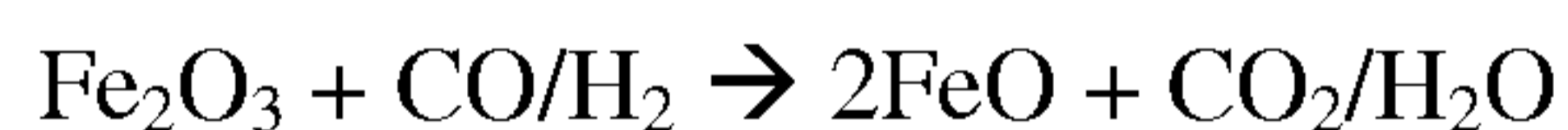
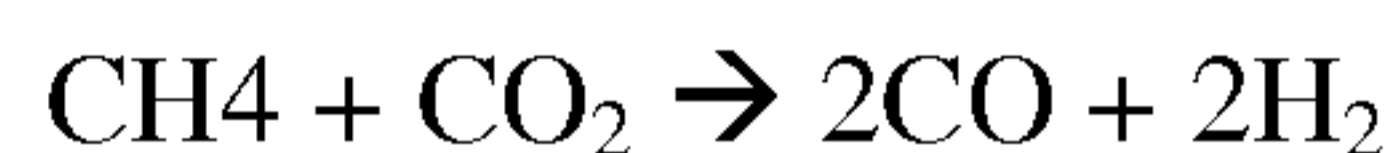
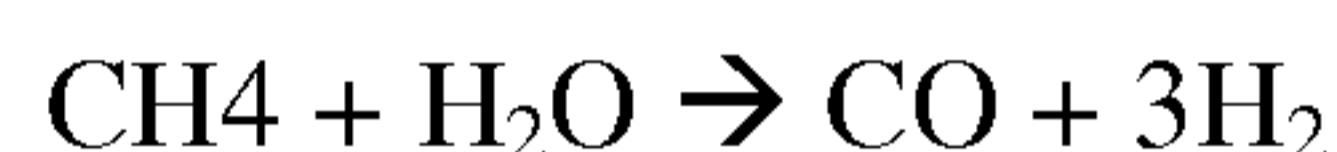

15 Fuel conversion enhancer such as CO_2 , steam, and/or hydrogen can also be introduced into the reducer stage 82 to enhance methane conversion based on mechanism similar to that shown in Fig. 3. The heat integration scheme for methane and other gaseous/liquid carbonaceous fuel conversion is similar to that explained in the solid fuel conversion scheme. Fig. 18 illustrates an embodiment for methane conversion.

20 The solid operating line shown in Fig. 16 is the desirable operating line for syngas conversion. The operating line for methane and other fuel conversion shows similar nature as Fig. 16. Although the slope of the operating line may change at various operating temperatures, fuel compositions, and pressures, the stoichiometric ratio between

-21-

the metal oxide composite particles and the gaseous fuel is usually maintained at from about 3:1 – 1.18:1. As a result, the metal oxide conversion usually ranges between 33% - 85% while greater than 95% of the gaseous fuel is converted to CO₂ and H₂O. For example, when methane is used, the metal oxide conversion usually ranges between 35% and 70%. When Fe₂O₃ based ceramic composite particles are used, the product from the reducer is a mixture of iron and Wuestite.

The gaseous fuel can be pretreated so that it contains less than 750 ppm of H₂S, COS, and some elemental mercury. The reducer configuration and the ceramic composite particles will allow the H₂S, COS, and mercury to exit the reducer without reacting with the ceramic composite. As a result, these pollutants can be sequestered along with CO₂.

Fig. 9 illustrates the conversion of syngas and iron oxide in a moving bed reducer stage when syngas is used as the gaseous fuel. Fig. 10 illustrates the conversion of methane and Fe₂O₃ in a moving bed reducer stage when methane is used as the gaseous fuel. Fe₂O₃-based ceramic composite is used in both cases. As can be seen, more than 99.8% fuel conversion can be achieved with ~ 50% Fe₂O₃ conversion.

A portion of the reduced ceramic composite is then introduced to the oxidizer 84. In the oxidizer, steam and/or CO₂ is introduced at or near the bottom and flows in a countercurrent manner relative to solids. The oxidizer configuration and gas and solid conversions are similar to that of the reducer in the solid fuel conversion system discussed previously.

Fig. 11 shows the concentration of the hydrogen product during a moving bed oxidizer operation. Average hydrogen purity of >99% was achieved.

The combustor shown in Fig. 8 is similar to the combustor in the system for fuel conversion. A preferred heat integration scheme utilizes the heat from the combustor to provide the heat requirement in the reducer. In a preferred configuration, spent ceramic composite is separated from the other particles using a cyclone or other mechanical separation techniques.

-22-

Fig. 12 shows the crushing strength of the ceramic composite. After treatment via reduction-oxidation cycles, the ceramic composite particles show a mean compressive strength of about 20 MPa.

Fig. 13 shows the attrition rate of the ceramic composite particles. The average
5 attrition of the ceramic composite particles is $< 0.6\%$ /reduction-oxidation cycle.

Fig. 14 shows the recyclability of the ceramic composite particles. The ceramic composite particles can sustain more than 100 reduction-oxidation cycles without losing their reactivity when syngas is used as the fuel.

Fig. 15 shows the recyclability of the ceramic composite particles. The
10 ceramic composite particles can react with various ranks of coal, syngas, and hydrocarbons for multiple cycles without losing their reactivity.

When the reducer and the oxidizer are moving beds and the combustor is an entrained bed, the preferred size of the ceramic composite particles are between about 200 μm to about 40 mm. Such a particle size allows for fluidization in the combustor without
15 fluidizing it in the reducer and the oxidizer.

Embodiments of the described systems and methods for converting solid fuel and hydrocarbons to carbon free energy carriers can reach an HHV energy conversion efficiency of up to about 90% for hydrogen production with a typical energy conversion efficiency of about 65 - 80%. Embodiments of the described systems and methods for
20 converting syngas fuel can reach an HHV energy conversion efficiency of up to about 85% for hydrogen production with a typical energy conversion efficiency of about 55 - 70%. Table 3 shows the performance of a biomass plant for power and H₂ Co-production.

-23-

Table 3 The performance of a biomass plant for power and H₂ Co-production

Biomass feed (lb/hr)	78800
HHV input (MW _{th})	100
Hydrogen (lb/hr)	3805 (69.05%)
Net Power (MW _e)	4.55 (4.55%)
Efficiency (%HHV)	73.6

In one configuration, the reducer can be integrated with a fluidized catalytic cracking unit. The reducer converts gaseous hydrocarbons in the hydrocracker while
 5 reducing the ceramic composite. The reduced ceramic composite is then introduced to the oxidizer to generate hydrogen. The hydrogen generated can then be used for hydrocracking.

In some cases, catalysts for reactions such as hydrocarbon reforming or water gas shift can be mixed with the ceramic composite to enhance the fuel conversion. The
 10 weight content of the catalyst typically ranges from about 0.01% to about 30%.

It will be apparent to those skilled in the art that various changes may be made without departing from the scope of the invention which is not considered limited to the specific embodiments described in the specification and drawings, but is only limited by the scope of the appended claims.

CLAIMS

1. A system for converting fuel comprising:
 - a first reactor comprising a moving bed of ceramic composite particles, said first reactor having a first stage and a second stage, said ceramic composite particles comprising at least one metal oxide disposed on a support; an inlet for providing fuel and a gas containing CO₂ and, optionally O₂, to said second stage; said first stage having a restricted flow outlet communicating with said second stage, and wherein the first reactor is configured to reduce the at least one metal oxide with said fuel to produce a reduced metal or a reduced metal oxide;
 - optionally, a second reactor communicating with said first reactor and configured to oxidize at least a portion of the reduced metal or reduced metal oxide from said first reactor to produce a metal oxide intermediate and a hydrogen and, optionally a CO rich gas stream;
 - a source of air; and
 - a third reactor communicating with said source of air and configured to regenerate the at least one metal oxide from the remaining portion of the solids discharged from the said first reactor and, optionally the solids discharged from the said second reactor, by oxidizing the metal oxide intermediate.
2. A system as claimed in claim 1 in which at least one of the first reactor and second reactor has a funnel shaped outlet.
3. A system as claimed in claim 1 in which at least one of the first reactor, second reactor, and third reactor are connected via non-mechanical gas sealing and solids flow control devices selected from the group consisting of a loop seal, an L-Valve, a J-Valve, an N-Valve, and a zone seal.
4. A system as claimed in claim 1 in which said first reactor has an annular opening between said first stage and said second stage which allows gas to move from both the solid discharge port of the first stage and the ceiling of the annular opening.

5. A system as claimed in claim 1 in which the said second reactor is a moving bed reactor with one or more stages, a multistage moving bed, a rotary kiln, or a step reactor with countercurrent flow between solid and gas.
6. A system as claimed in claim 1 in which said second reactor includes a funnel-shaped outlet.
7. A system as claimed in claim 1 in which the said third reactor is a fast fluidized bed reactor, an entrained bed reactor, a transport bed reactor, or a mechanical conveying system.
8. A system as claimed in claim 1 in which the said third reactor comprises two stages, with the first stage comprising a bubbling or turbulent fluidized bed reactor and the second stage comprising an entrained bed, fast fluidized bed, or transport bed reactor.
9. A system for converting fuel comprising:
 - a first reactor comprising a shell side and a tube side, a first inlet in said shell side for providing a carbonaceous fuel to said first reactor and a second inlet for providing a plurality of ceramic composite particles comprising at least one metal oxide disposed on a support to said shell side of said first reactor; and a first inlet in said tube side of said first reactor for providing an oxygen-containing gas to said first reactor; wherein the first reactor is configured to reduce the at least one metal oxide with said fuel to produce a reduced metal or a reduced metal oxide, and wherein at least a portion of the composite particles and fuel are directly sent to said tube side of said first reactor where the heat of combustion provides heat to the reaction in said shell side of said first reactor;
 - a second reactor configured to oxidize at least a portion of the reduced metal or reduced metal oxide from the said first reactor to produce a metal oxide intermediate and a hydrogen rich gas stream;
 - a source of air; and
 - a third reactor communicating with said source of air and configured to regenerate the at least one metal oxide from the remaining portion of the solids discharged from the said first

reactor and, optionally the solids discharged from the said second reactor, by oxidizing the metal oxide intermediate.

10. A system as claimed in claim 9 wherein solids discharged from the second reactor are recycled to the tube side of the first reactor.

1 / 12

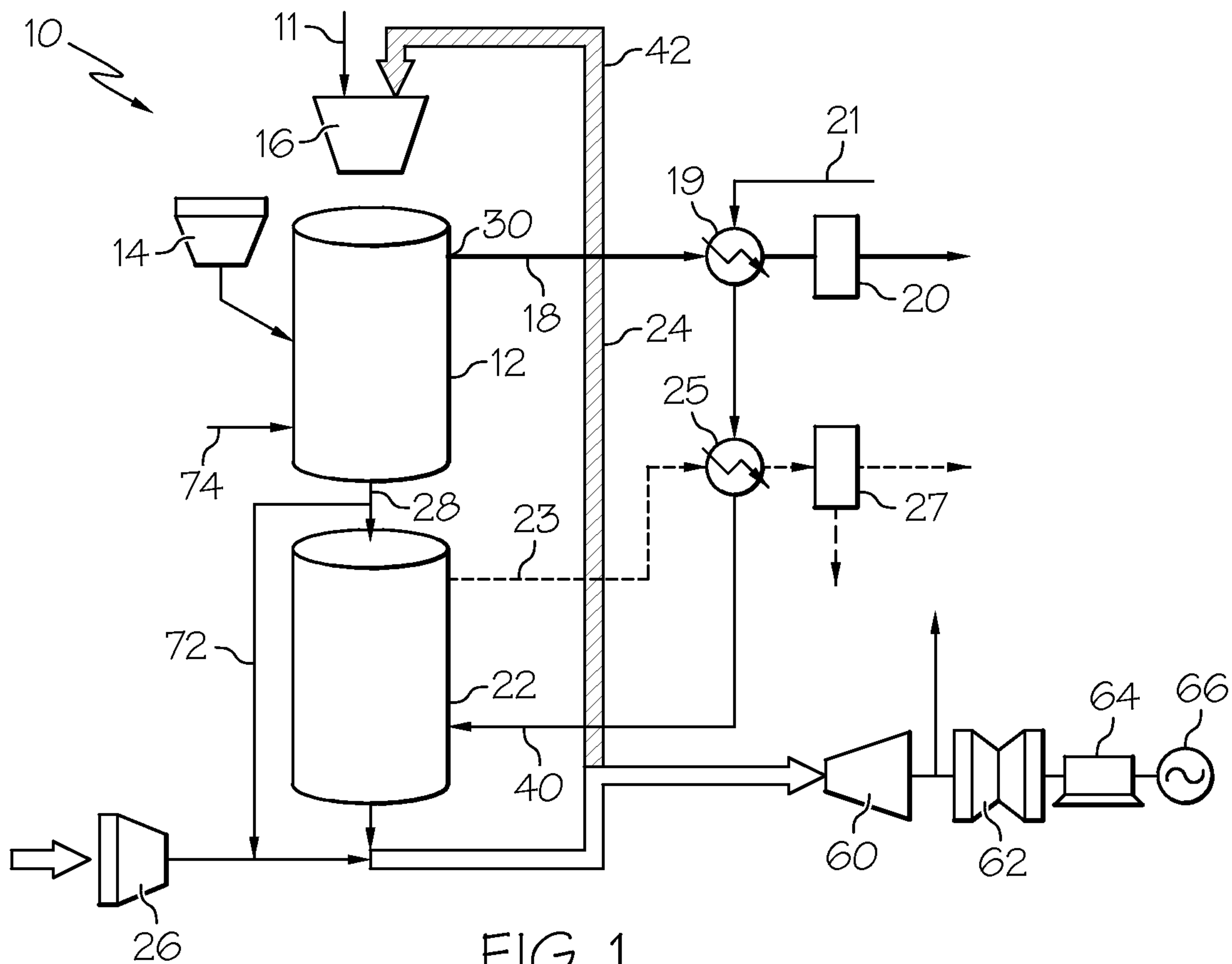

FIG. 1

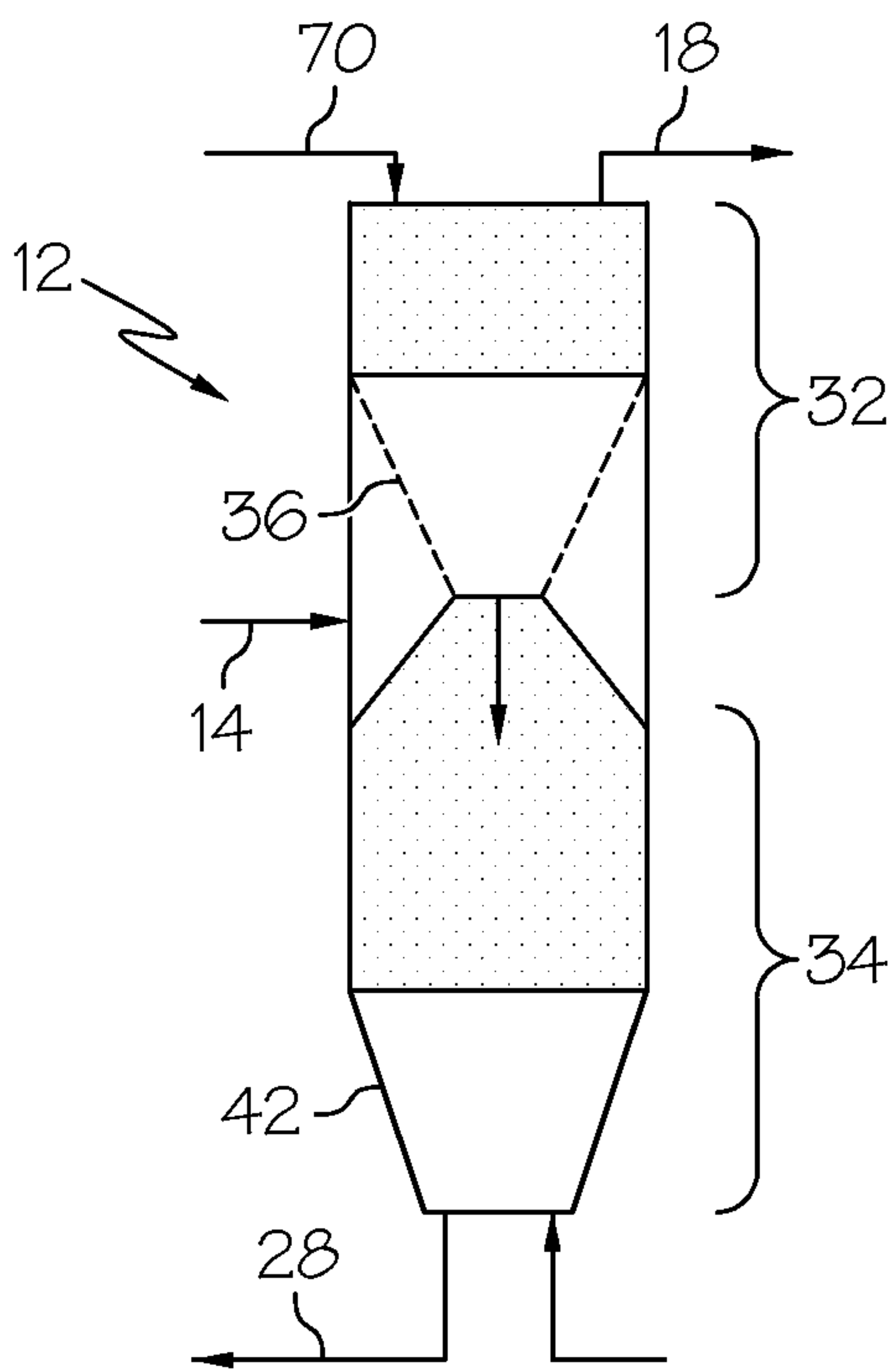

FIG. 2A

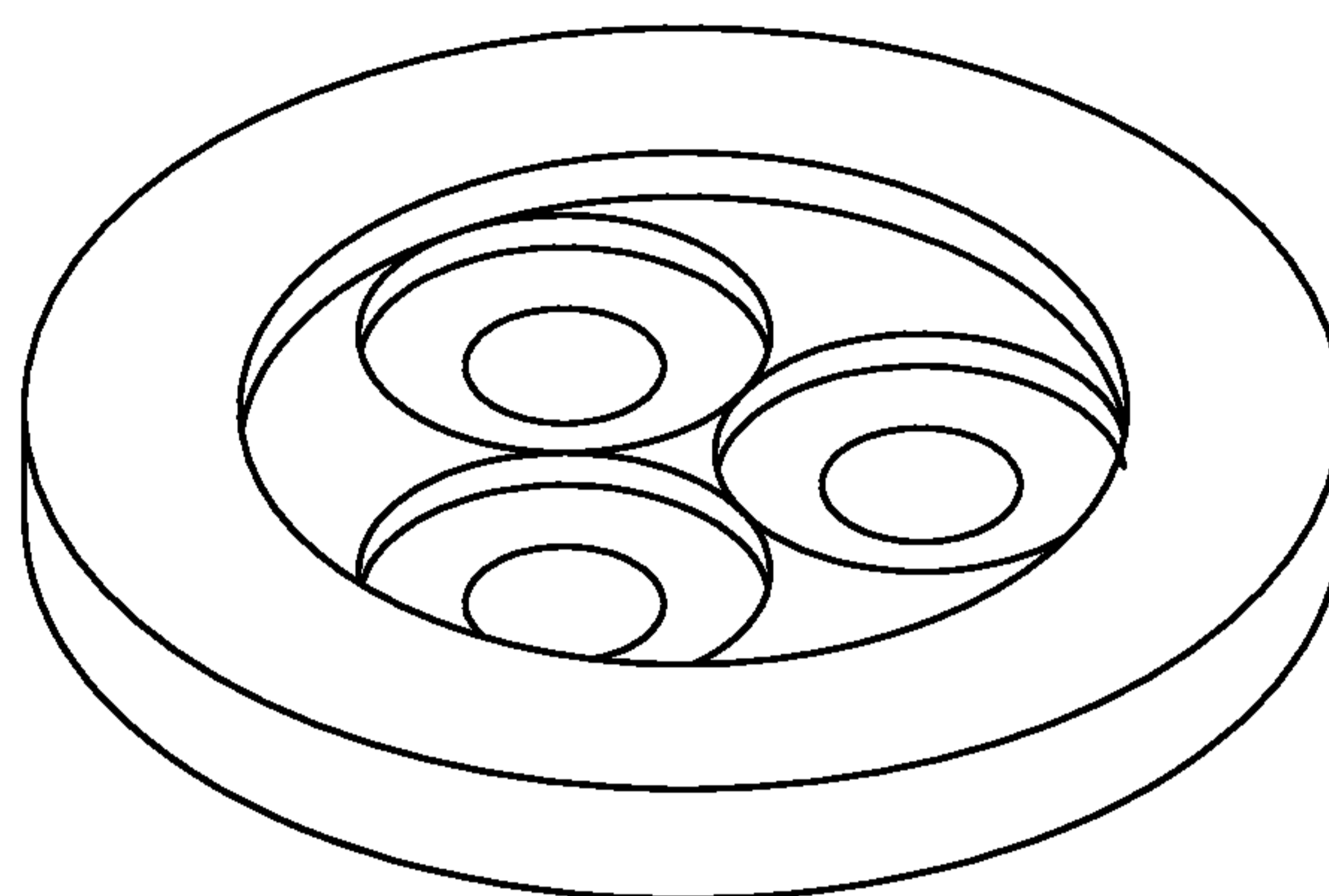

FIG. 2B

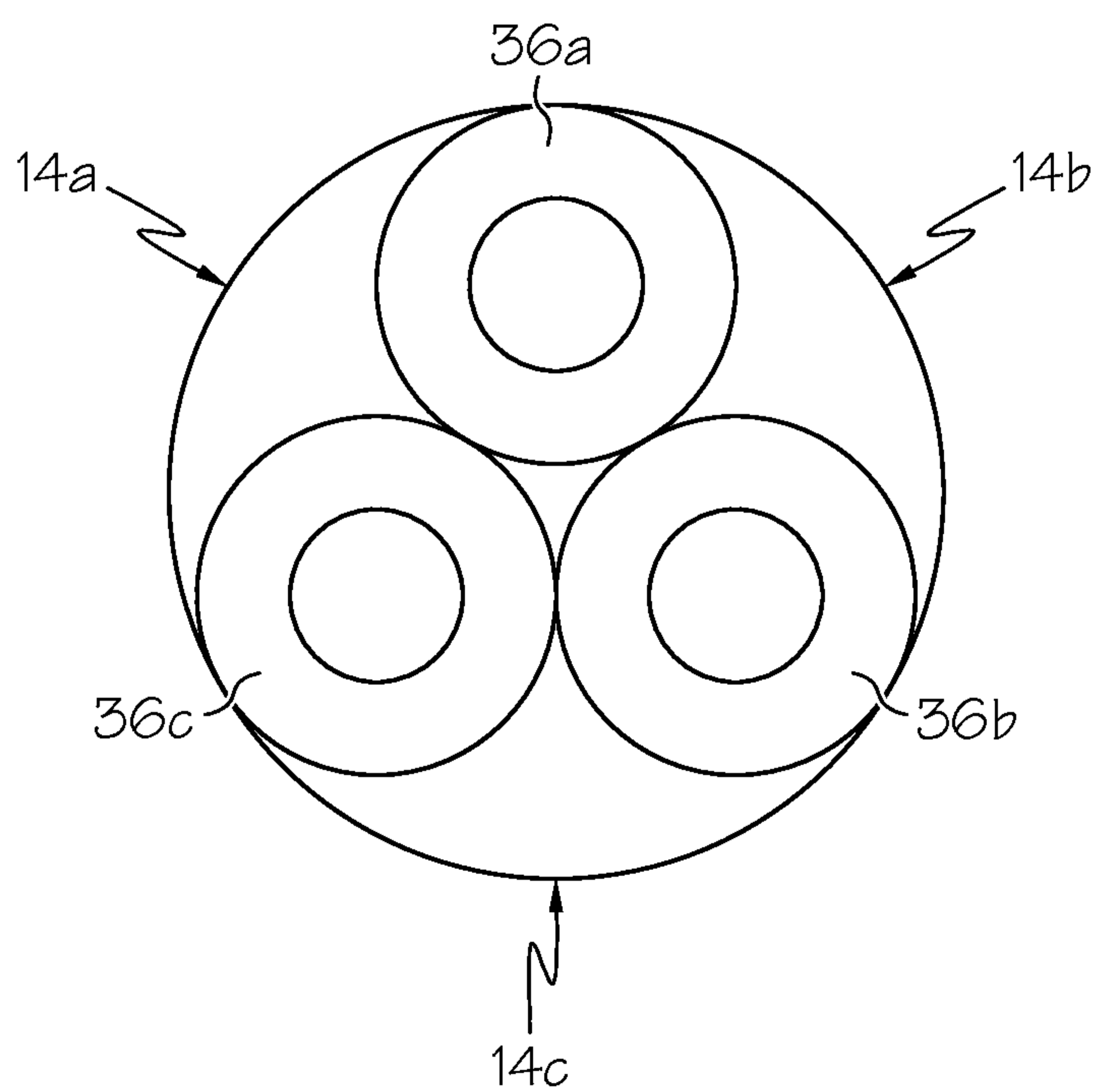

FIG. 2C

3 / 12

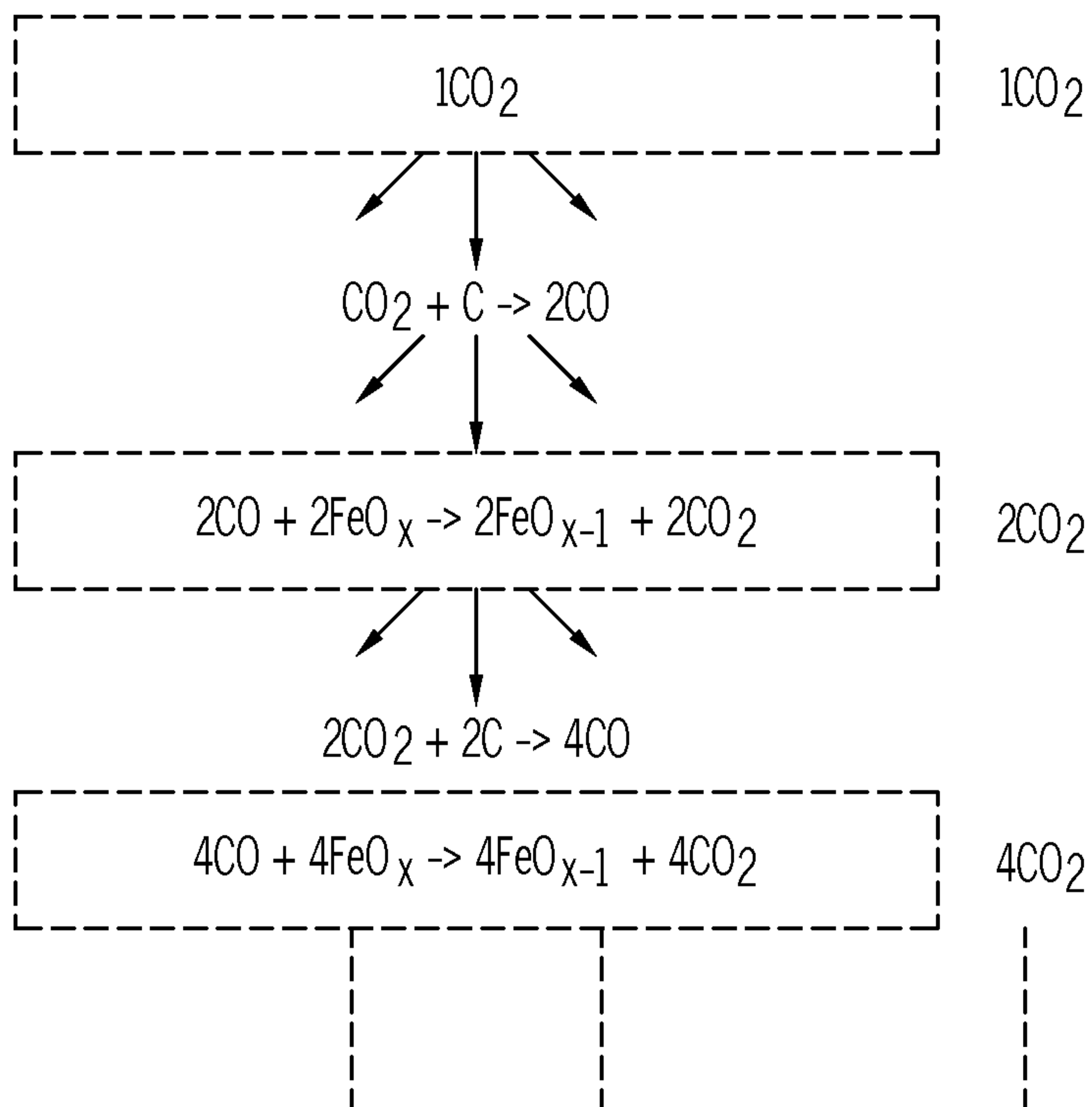

FIG. 3

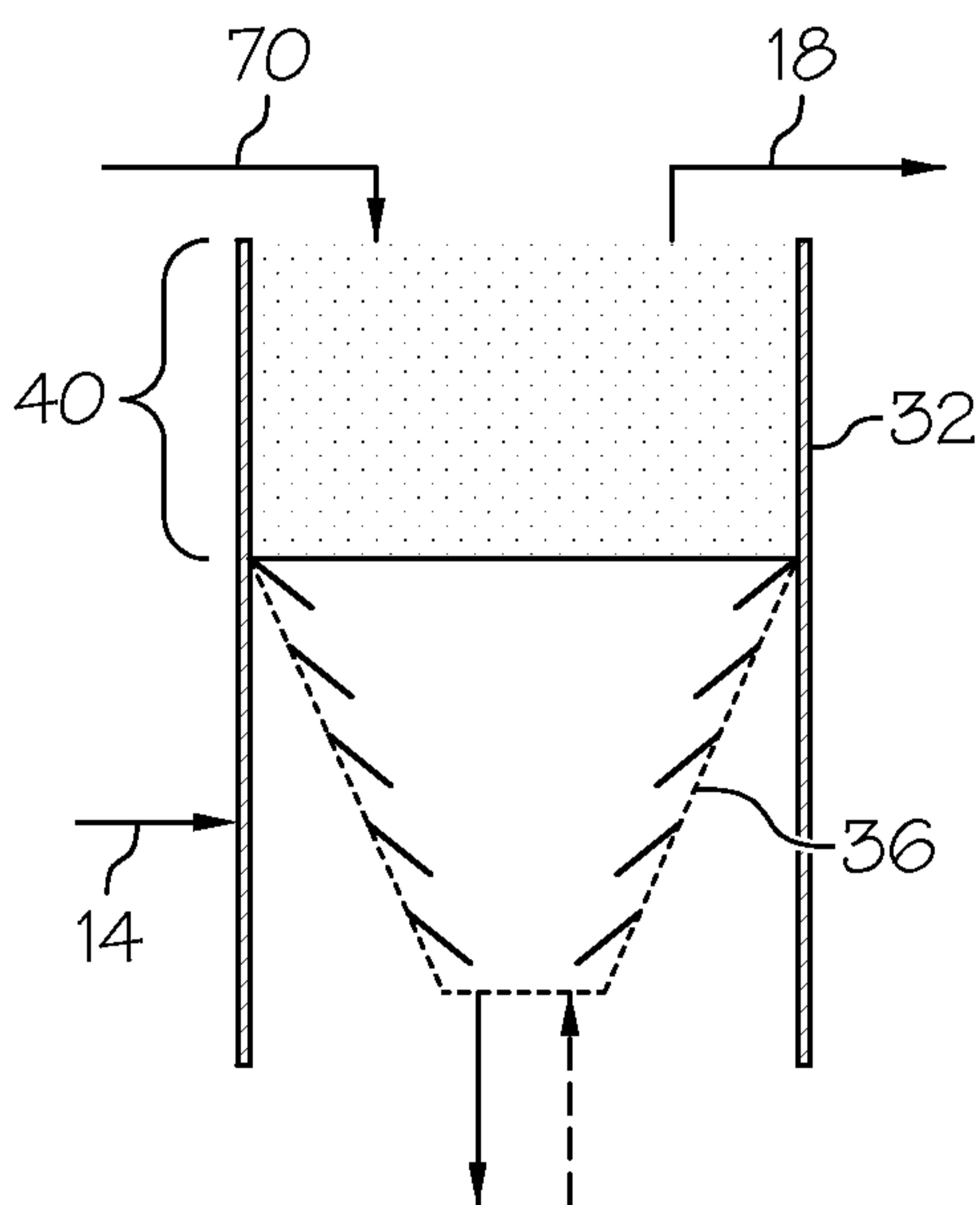

FIG. 4A

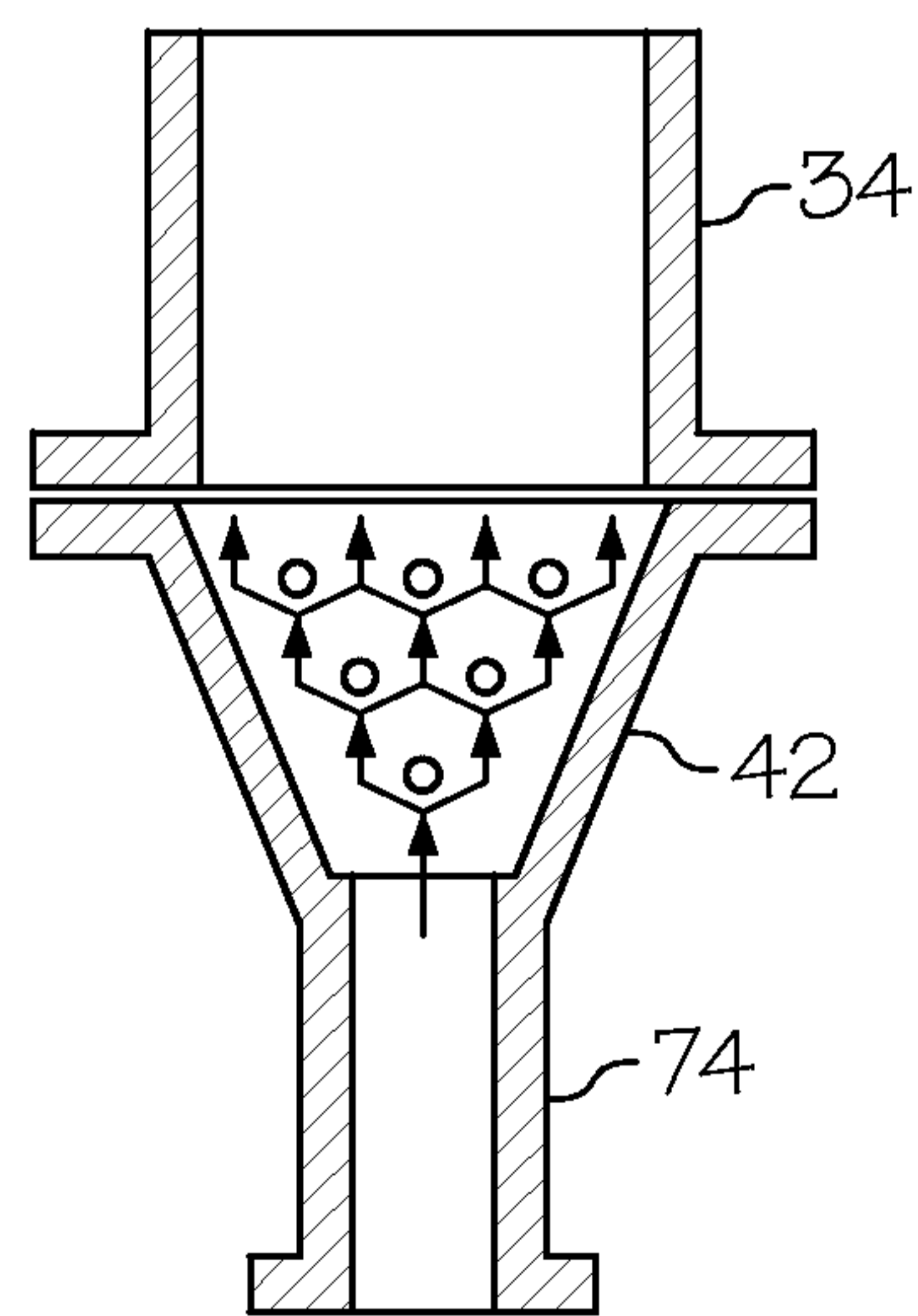

FIG. 4B

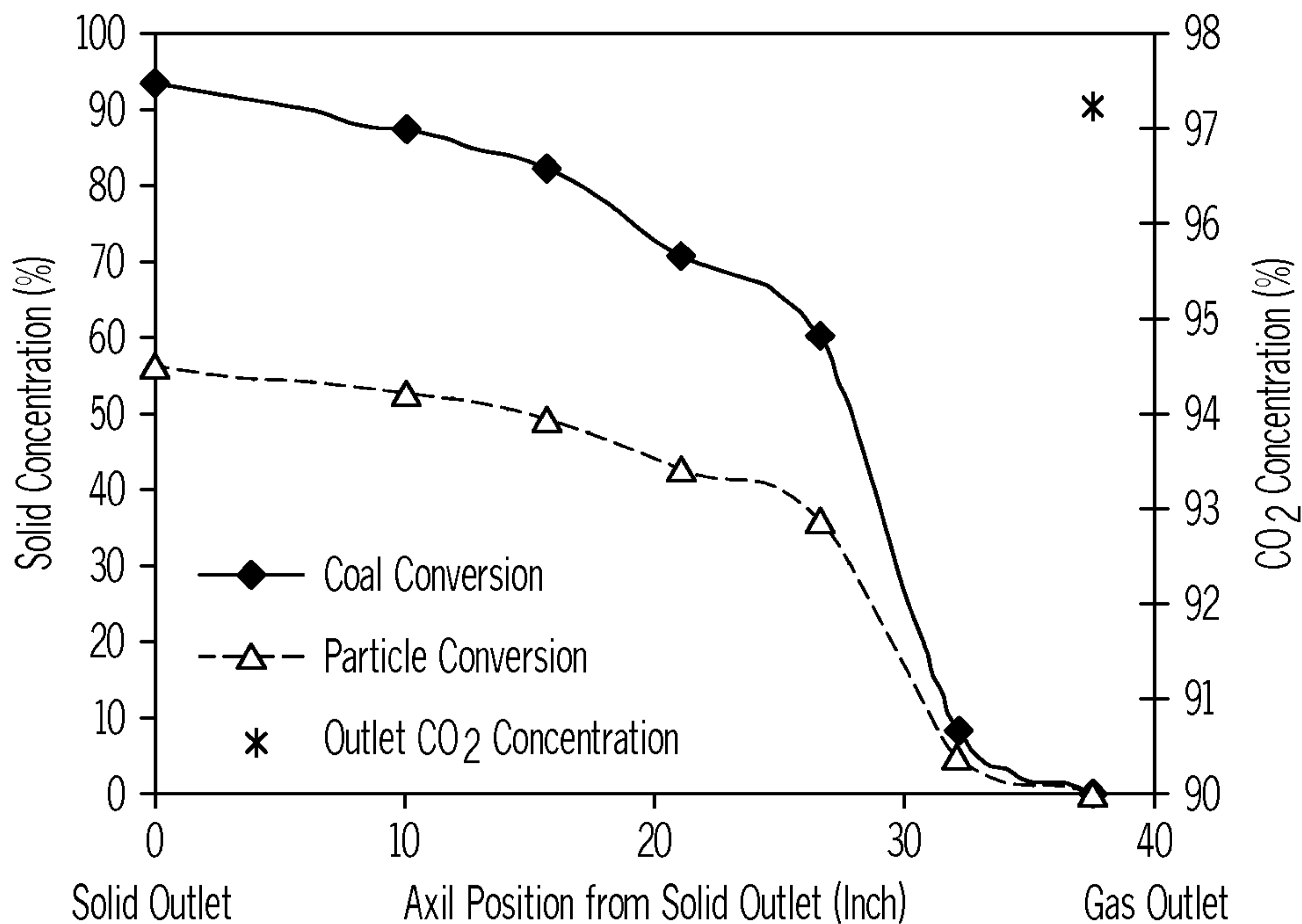

FIG. 5

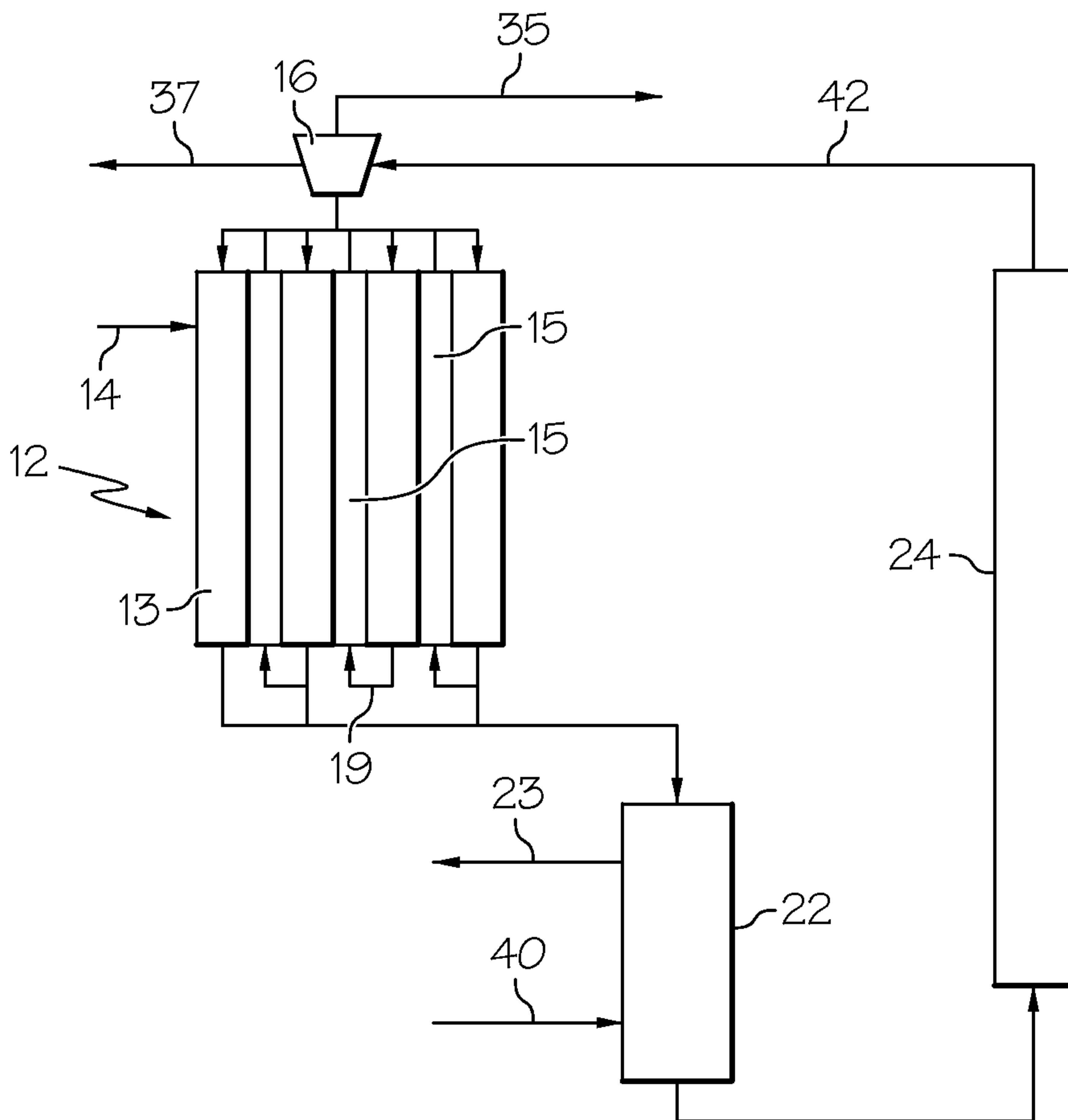

FIG. 6

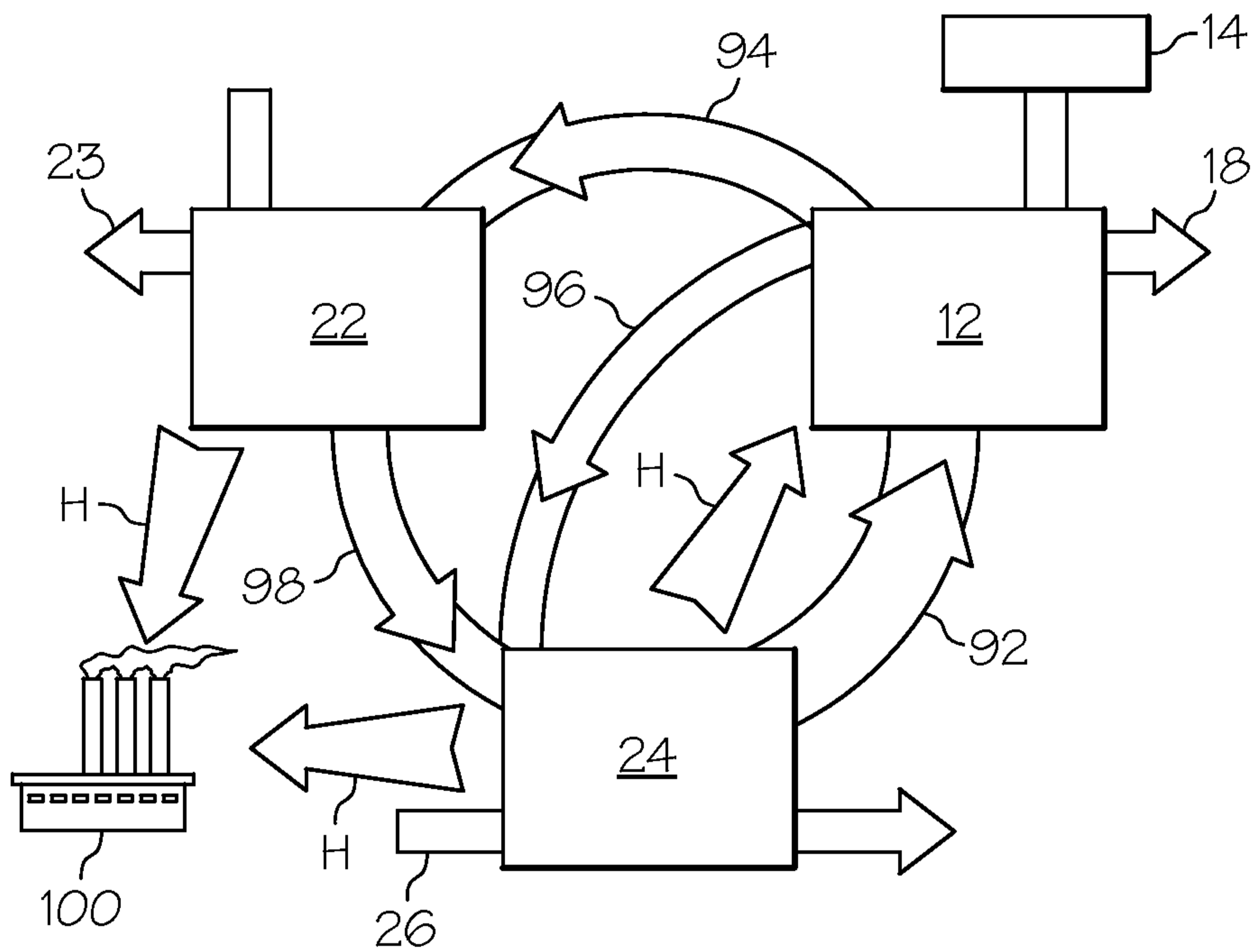

FIG. 7

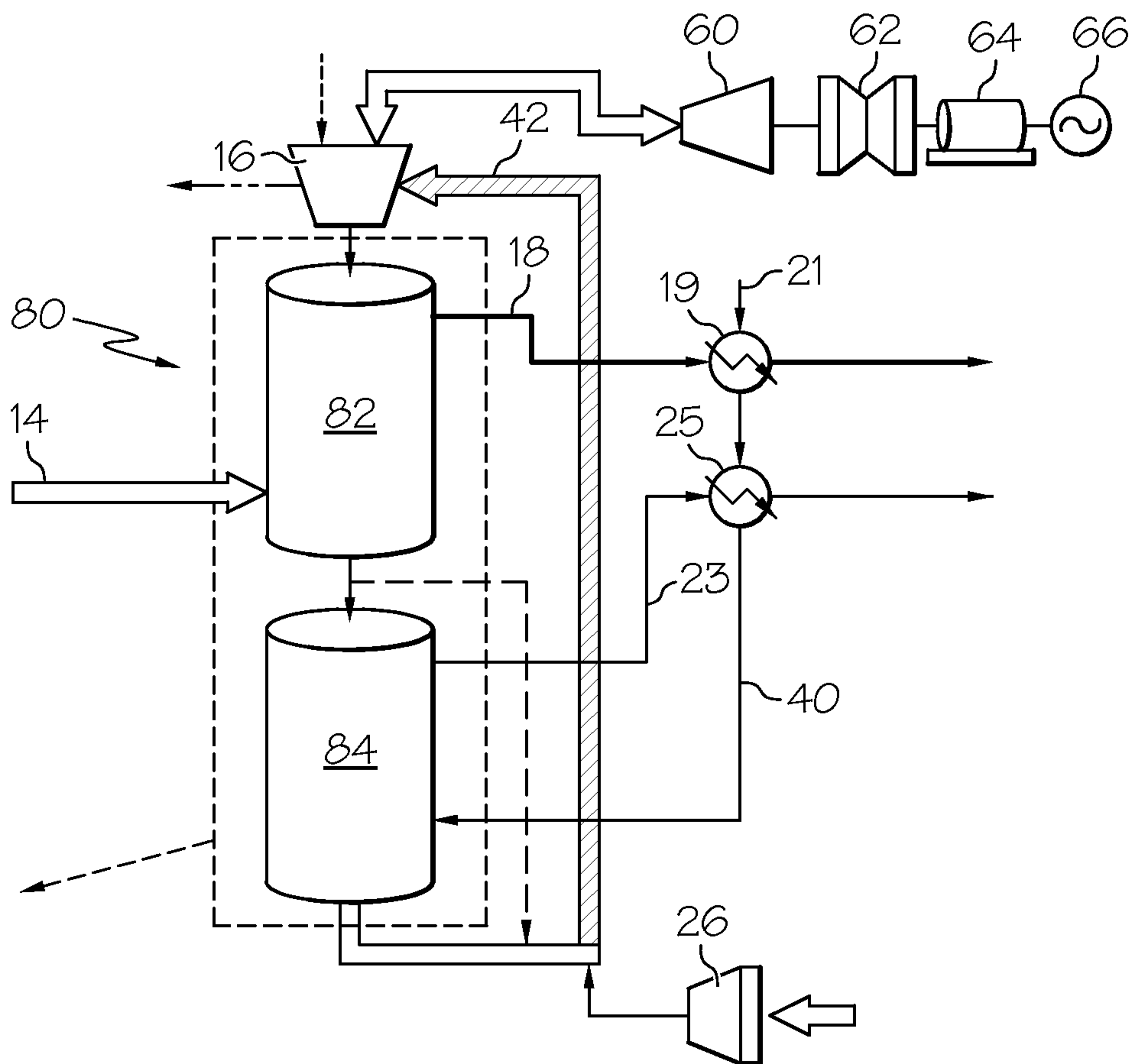

FIG. 8

6 / 12

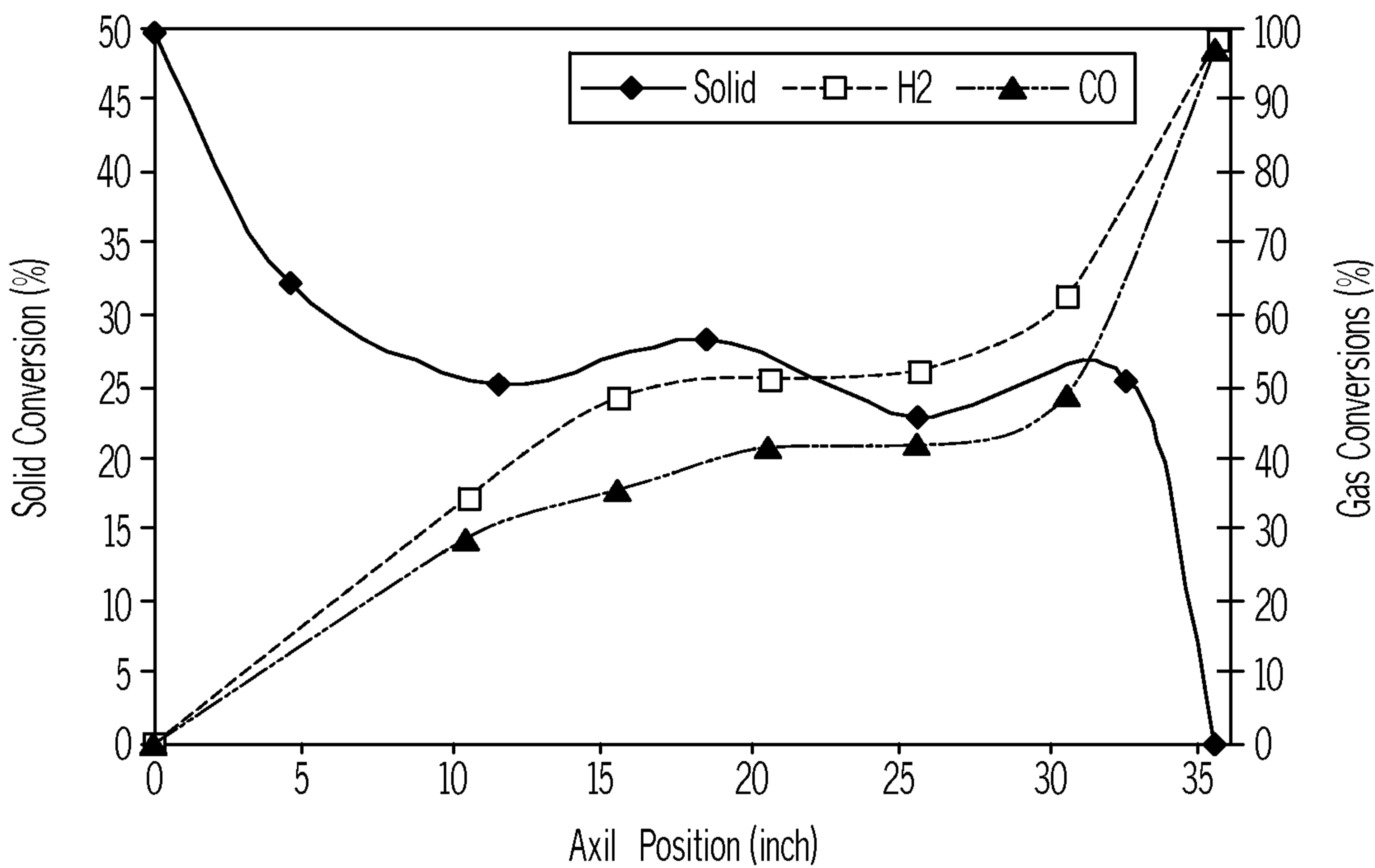

FIG. 9

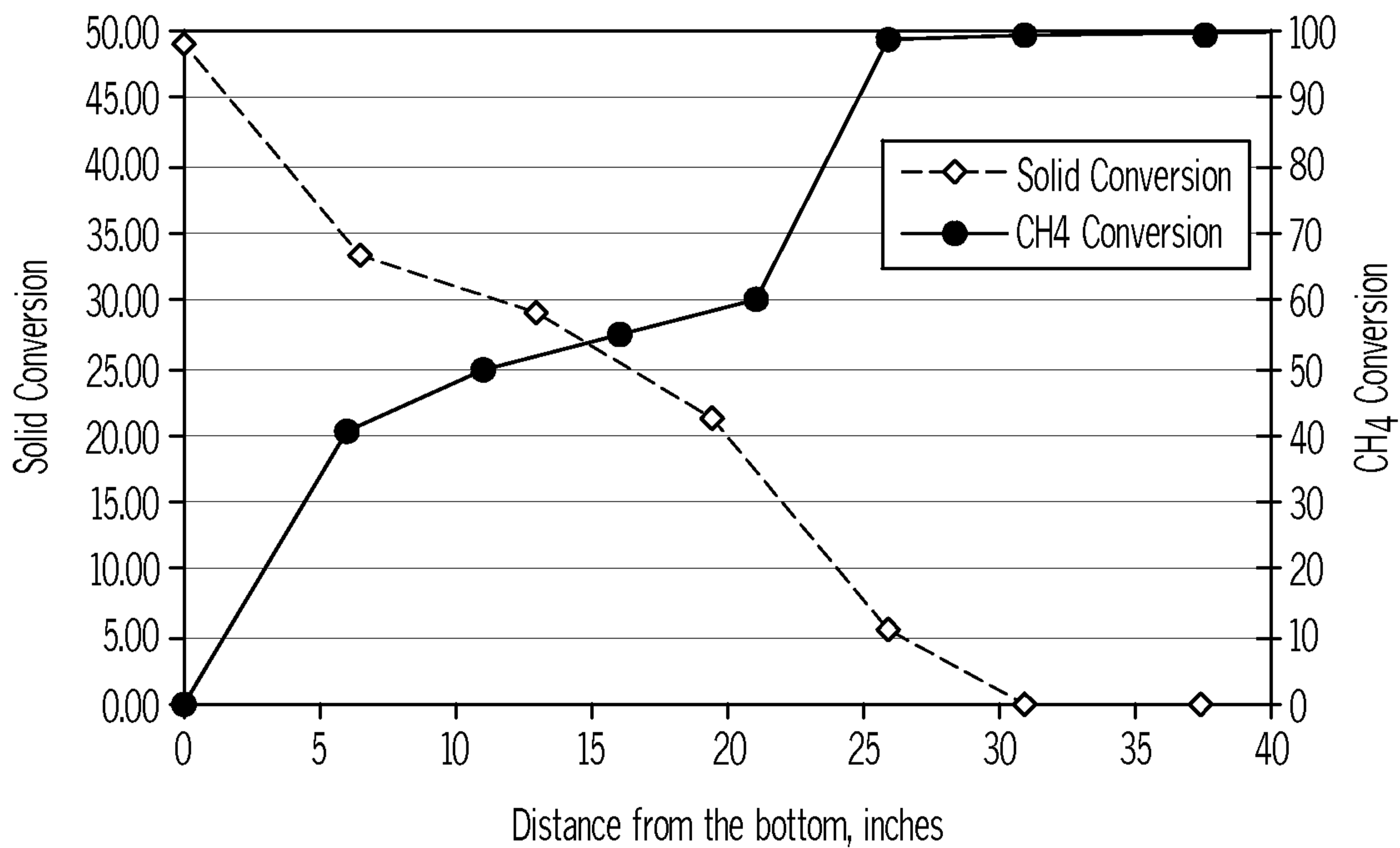

FIG. 10

7 / 12

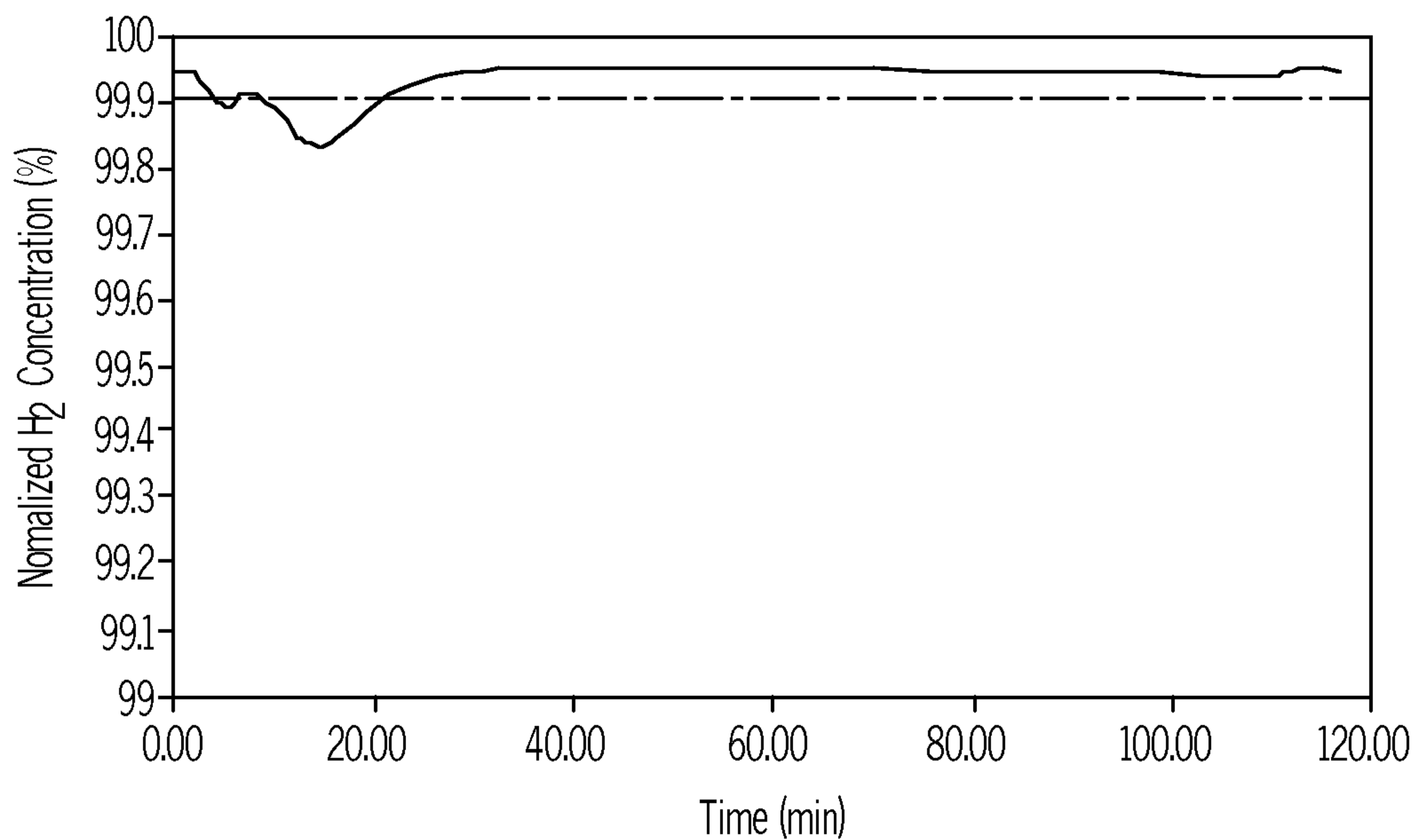

FIG. 11

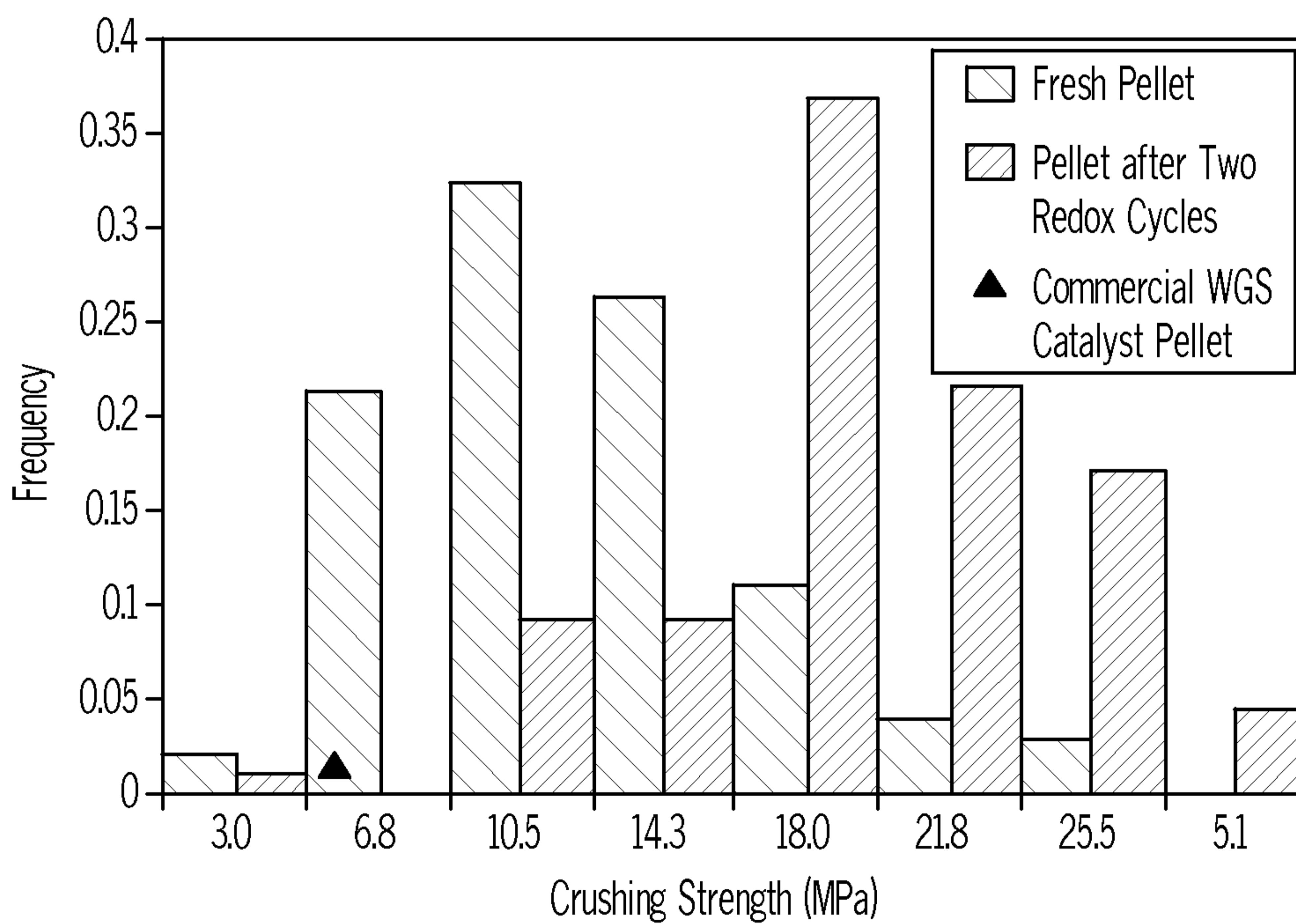

FIG. 12

8 / 12

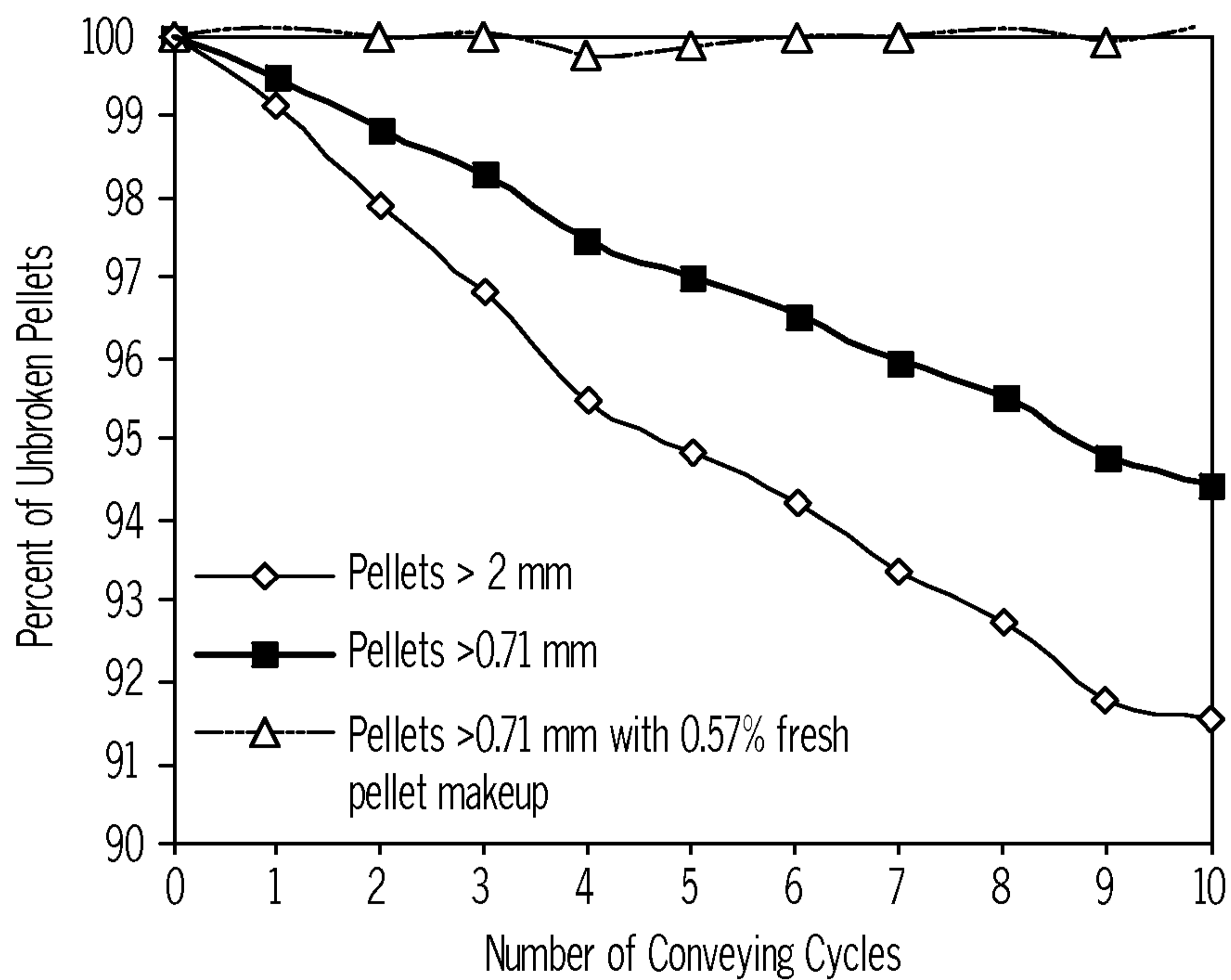

FIG. 13

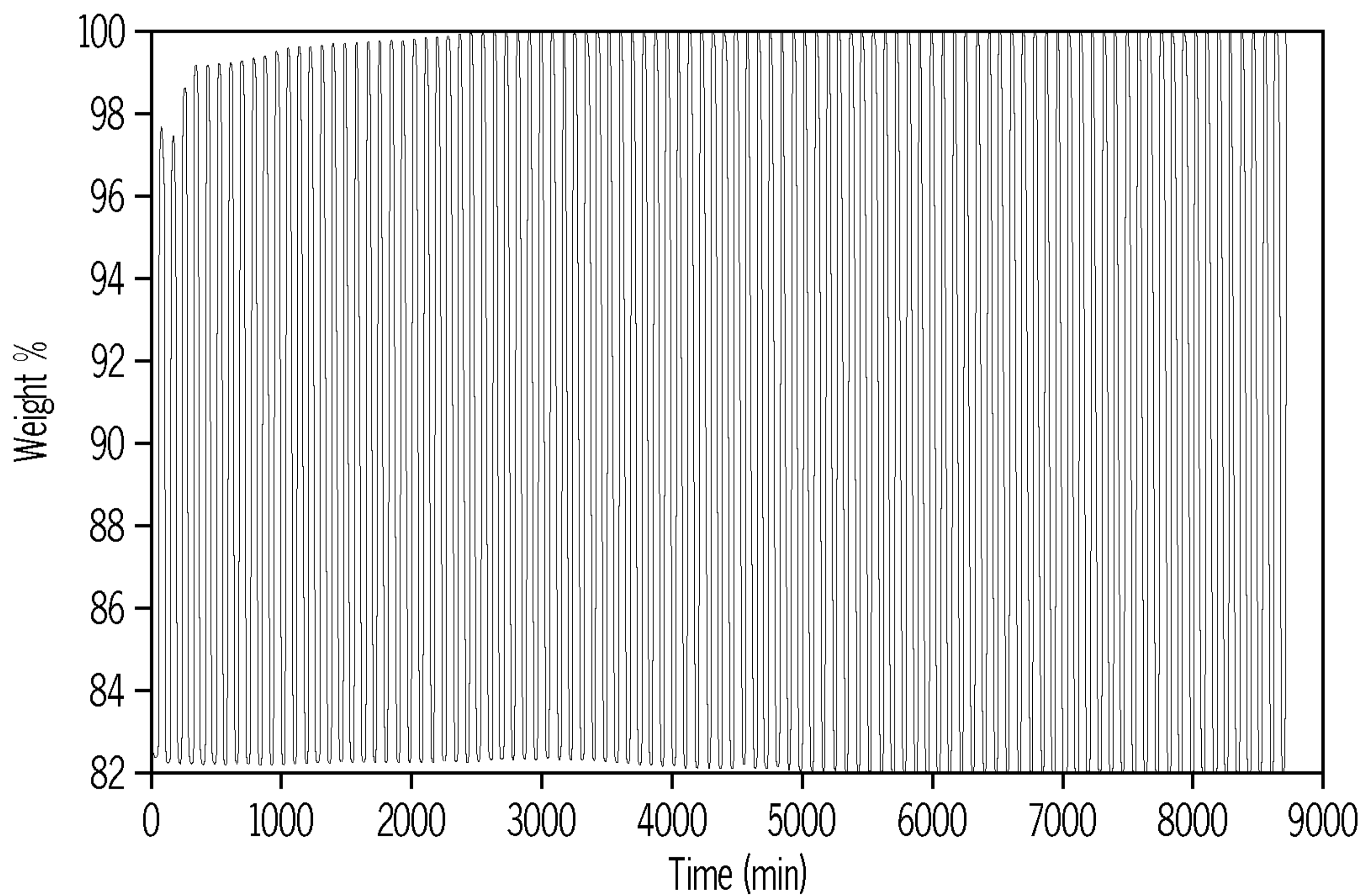

FIG. 14

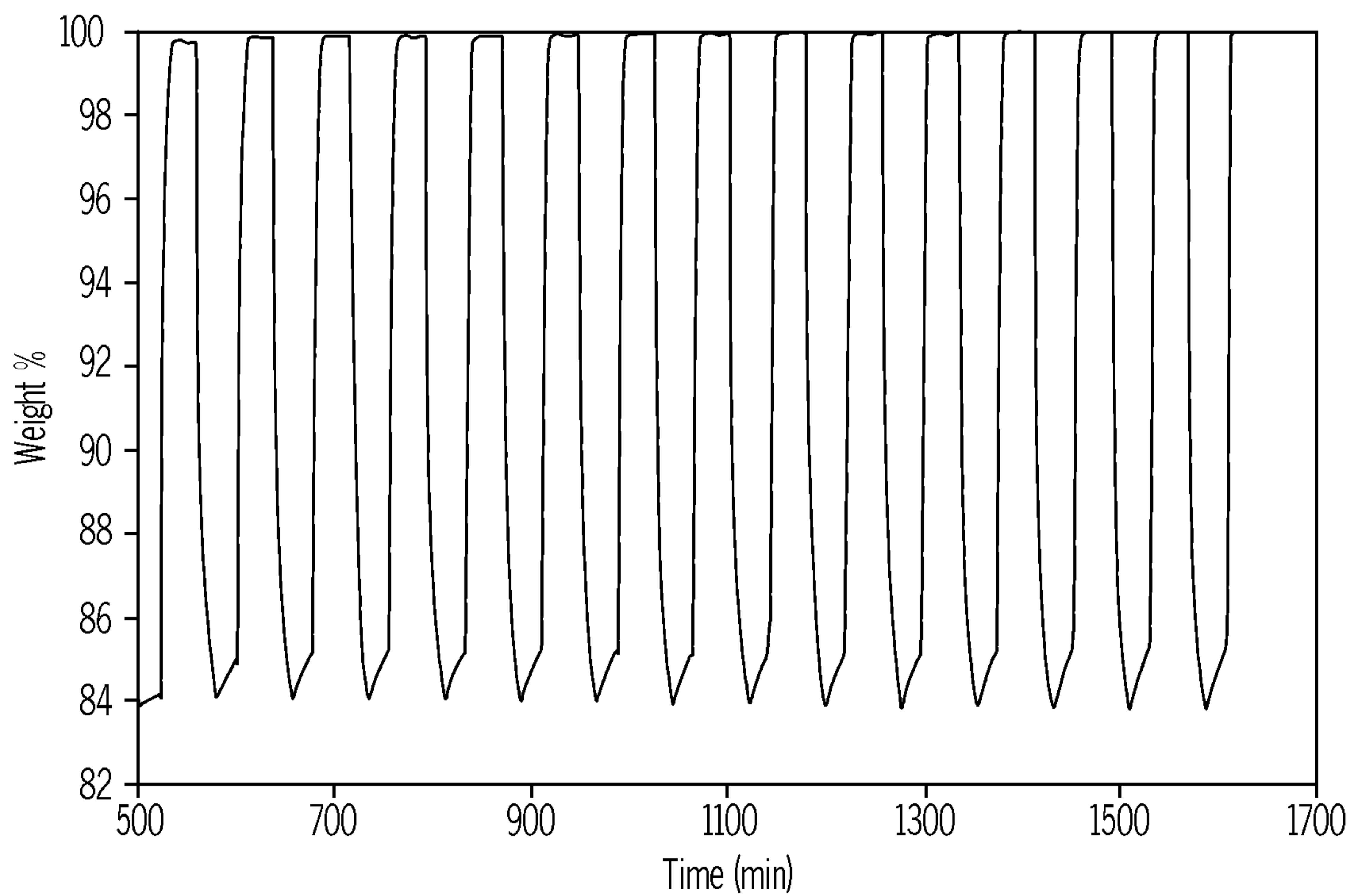

FIG. 15

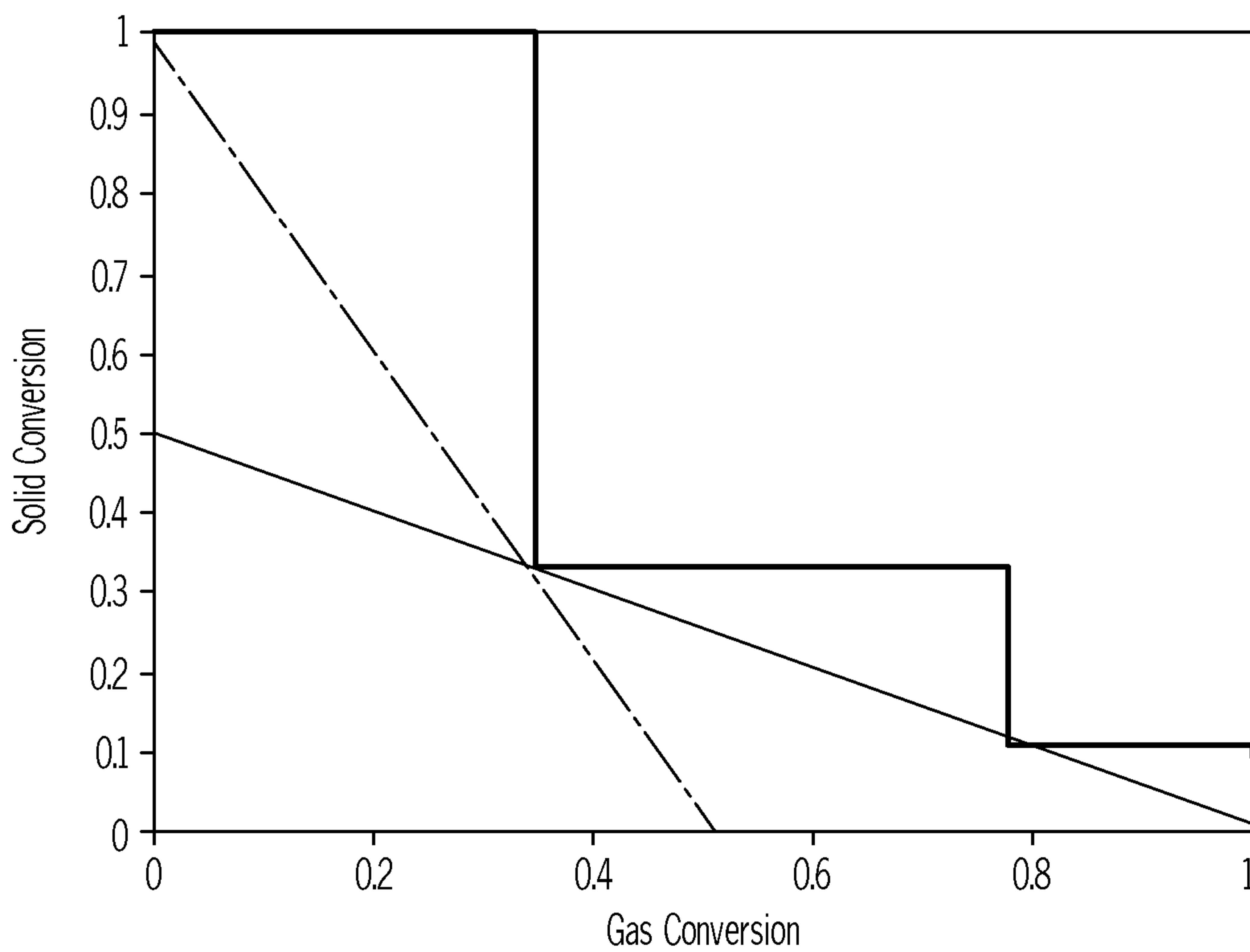

FIG. 16

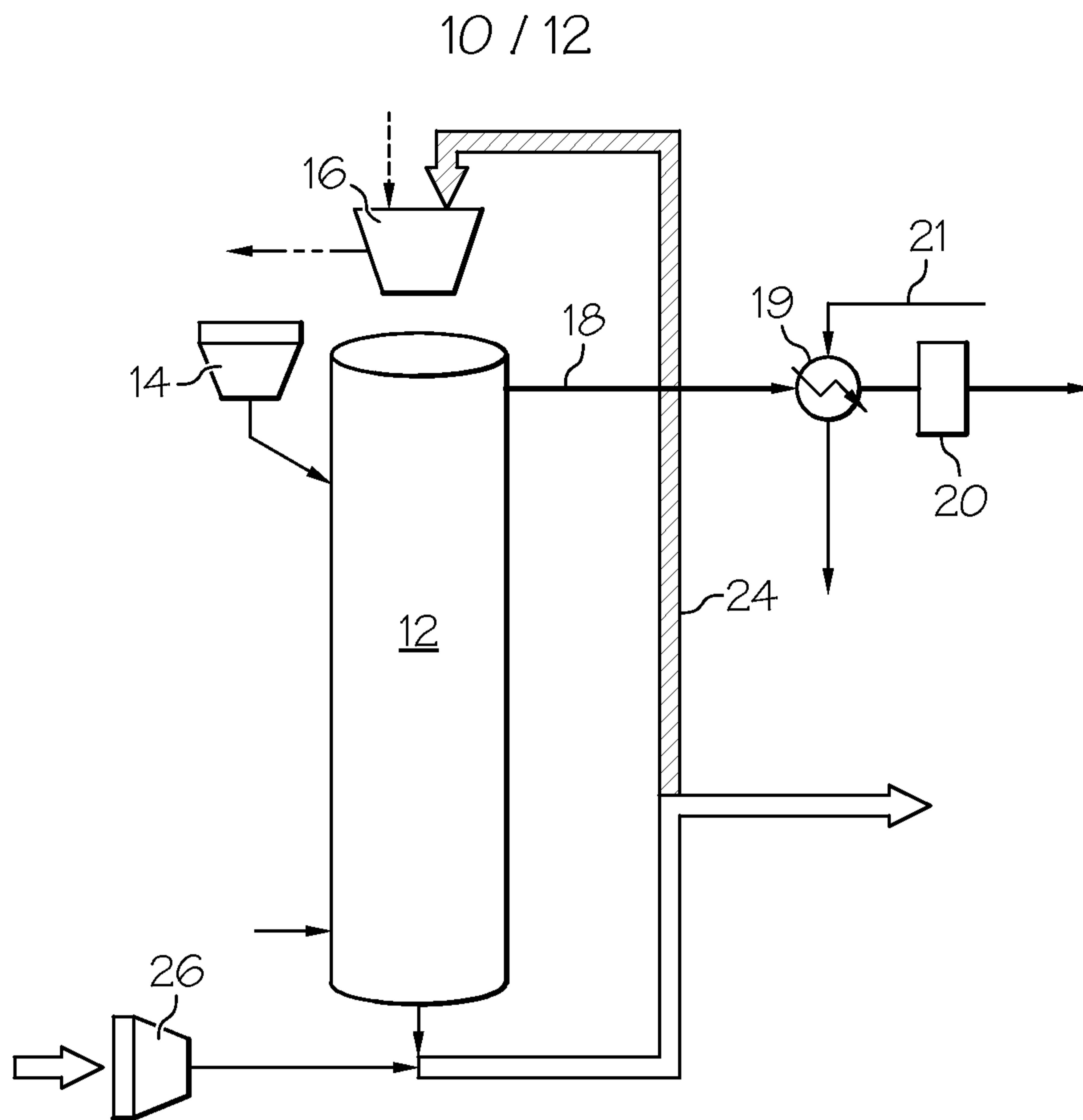

FIG. 17

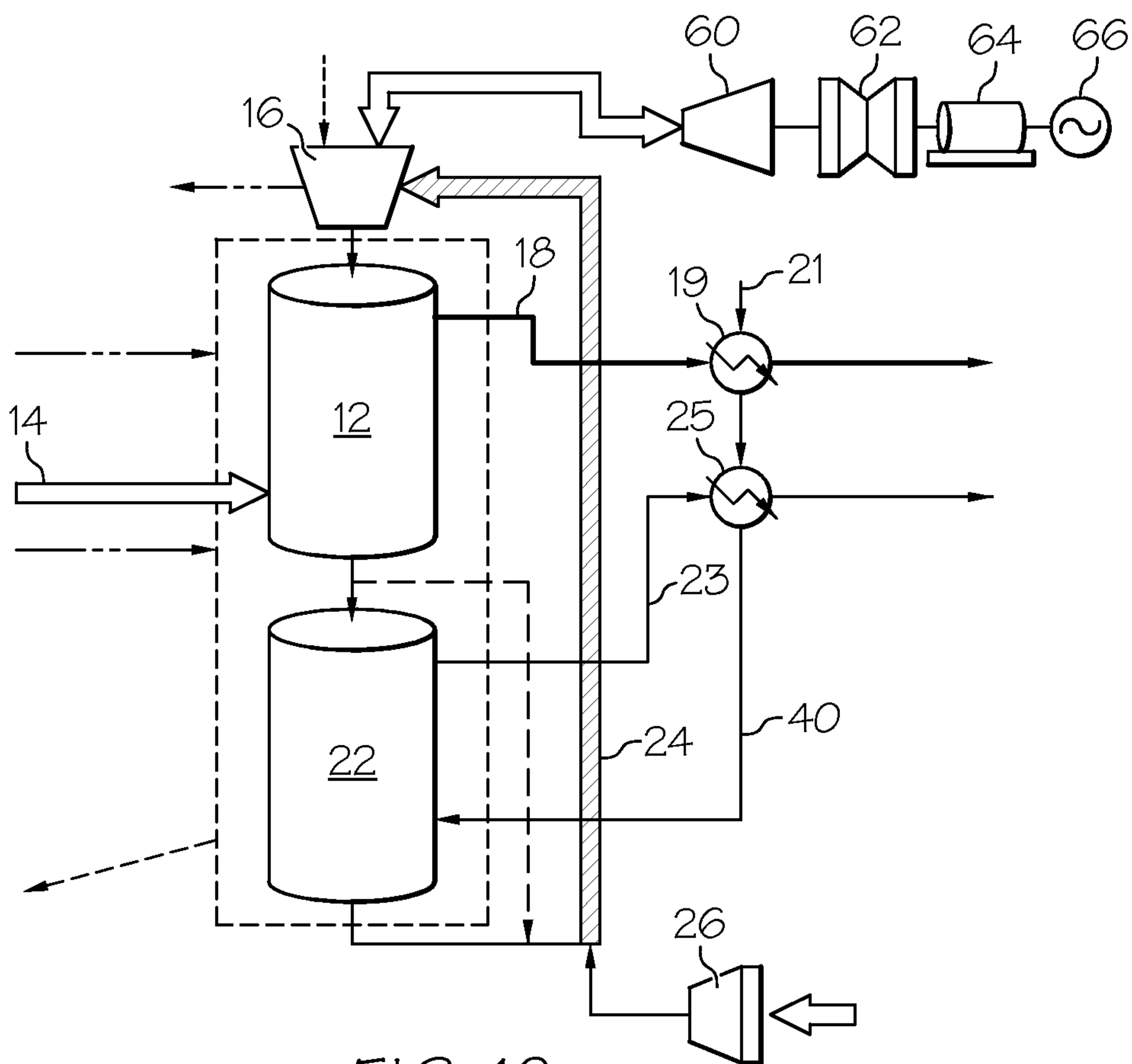

FIG. 18

11 / 12

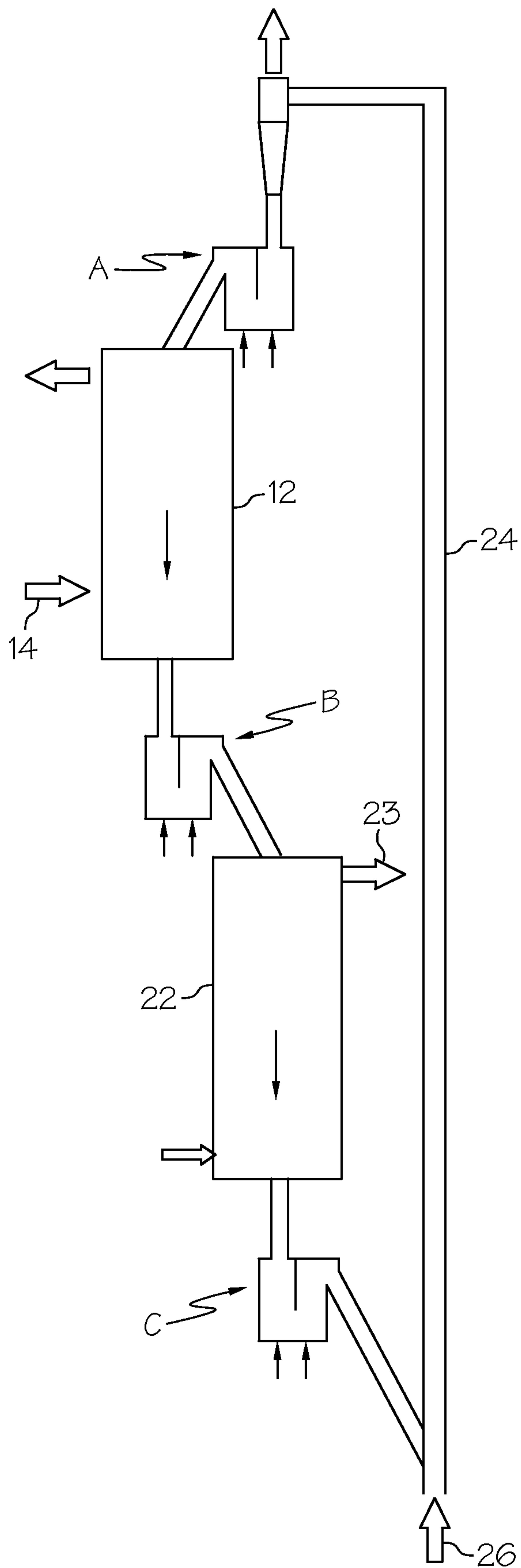

FIG. 19

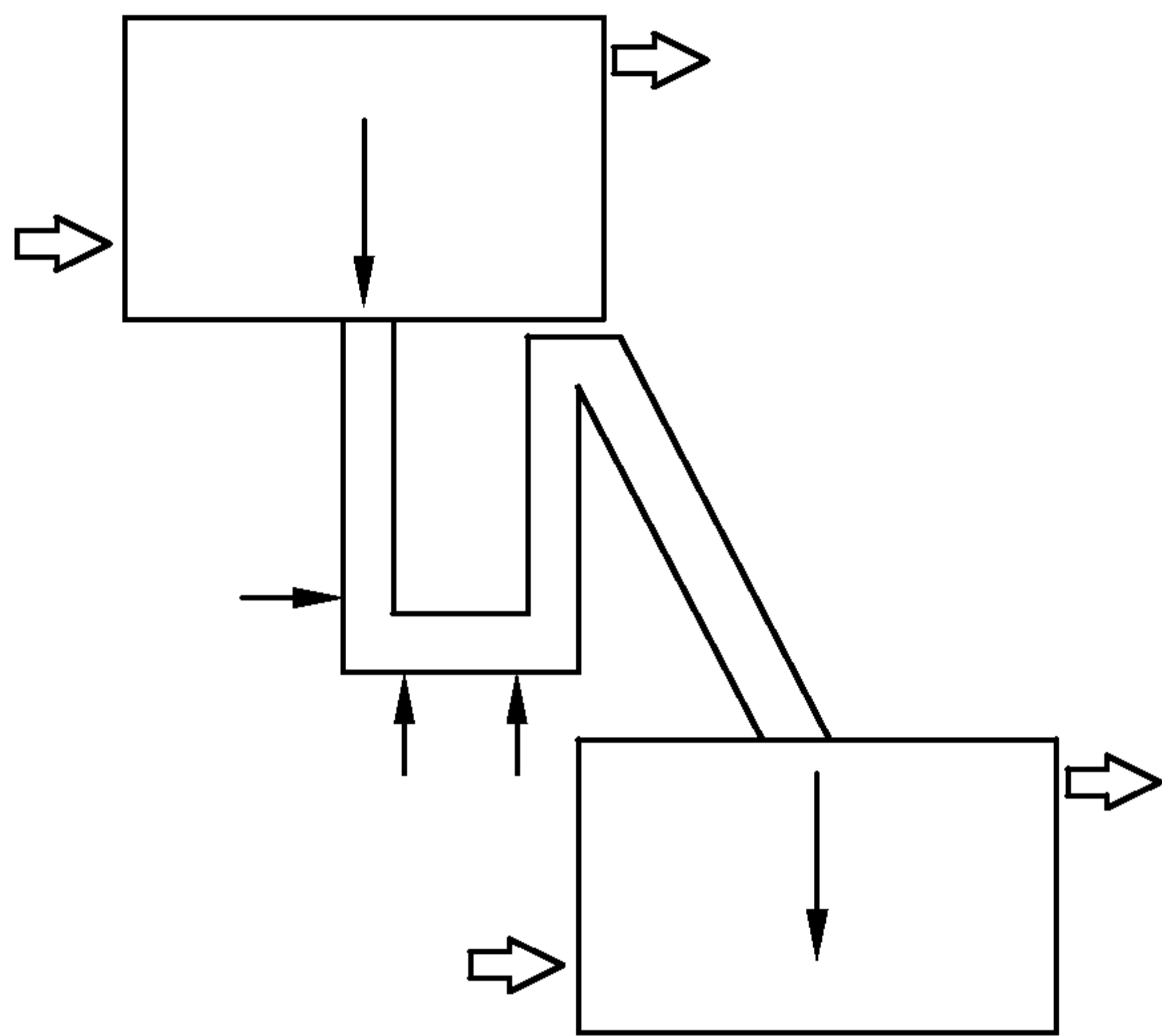

FIG. 20A

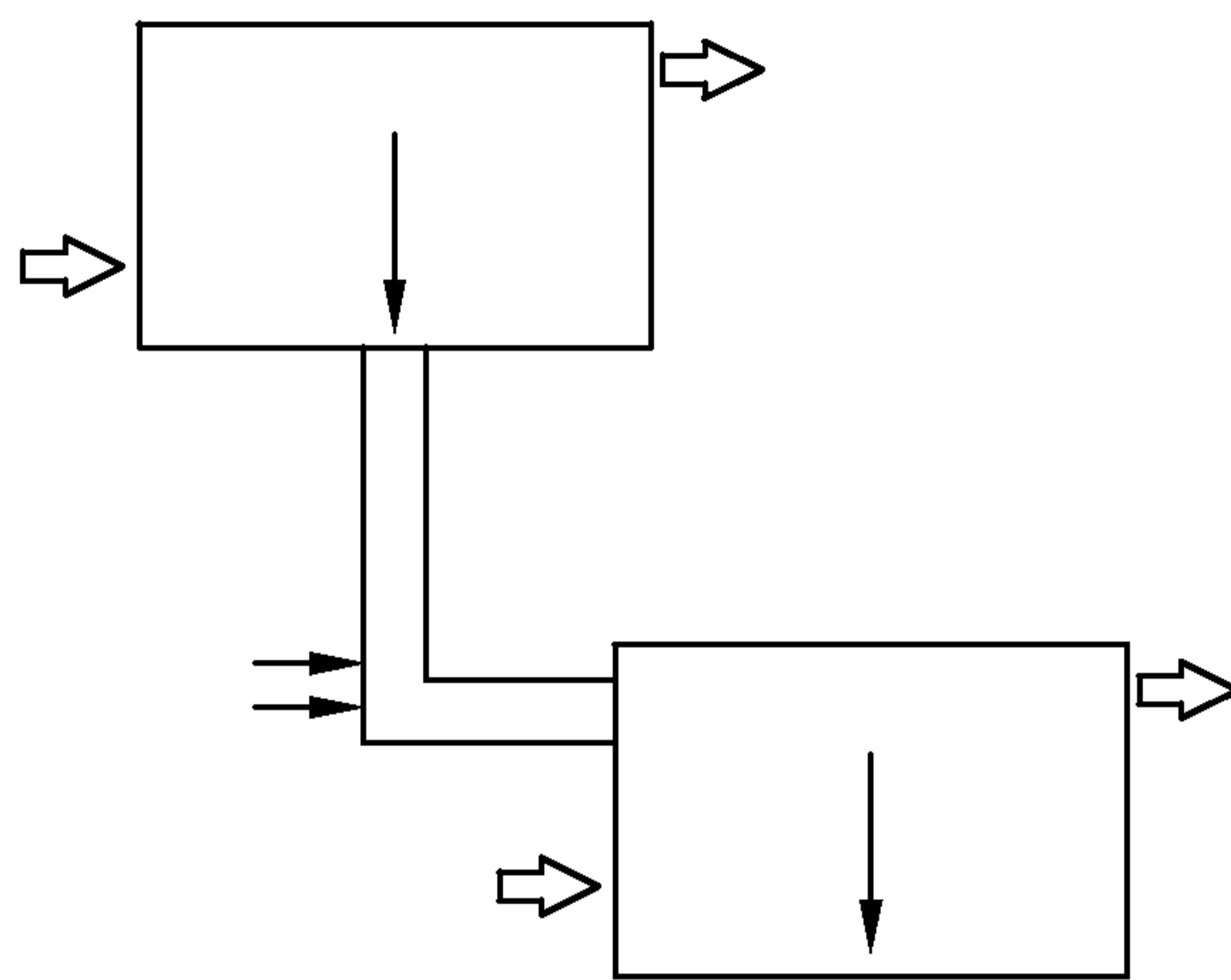

FIG. 20B

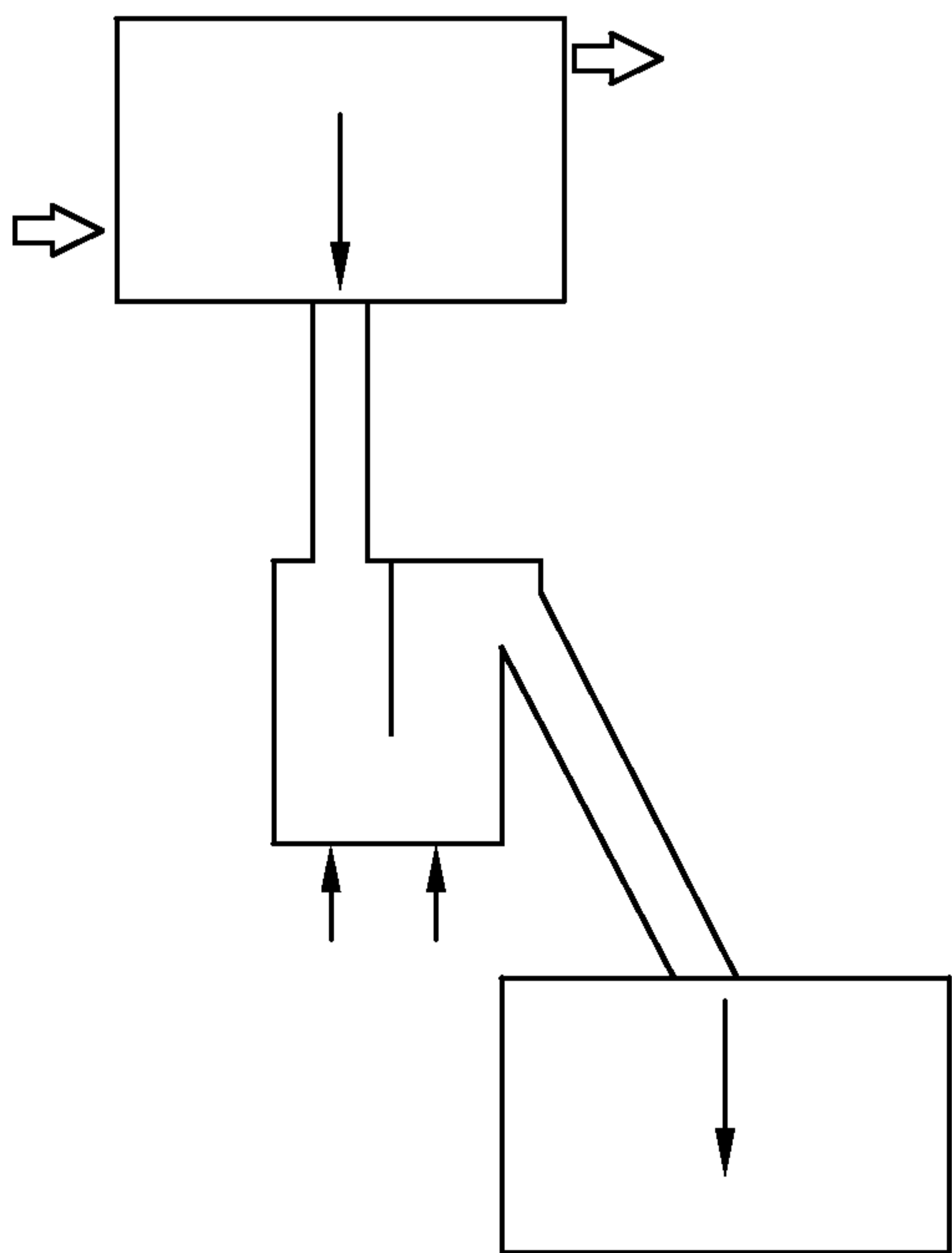

FIG. 20C

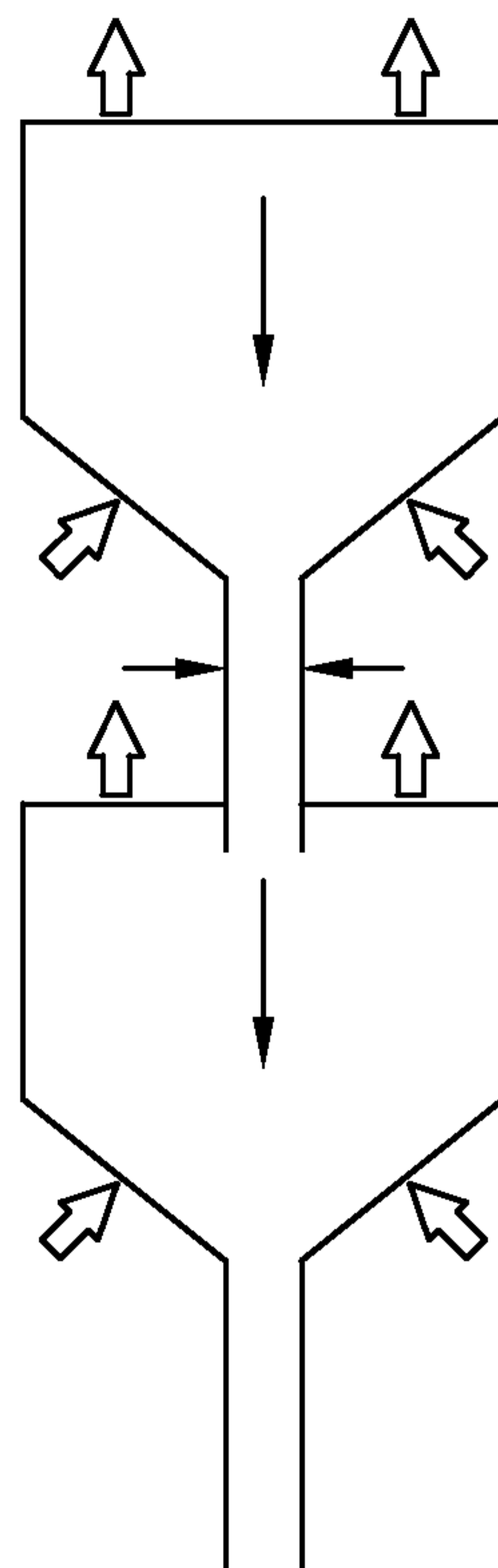

FIG. 20D

