

(19) World Intellectual Property Organization
International Bureau



(43) International Publication Date
10 February 2005 (10.02.2005)

PCT

(10) International Publication Number
WO 2005/013623 A1

- (51) International Patent Classification⁷: H04N 13/00, 7/26, G06T 15/10, 15/20, 5/00
- (21) International Application Number: PCT/IB2004/051315
- (22) International Filing Date: 28 July 2004 (28.07.2004)
- (25) Filing Language: English
- (26) Publication Language: English
- (30) Priority Data: 03102431.8 5 August 2003 (05.08.2003) EP
- (71) Applicant (for all designated States except US): KONINKLIJKE PHILIPS ELECTRONICS N.V. [NL/NL]; Groenewoudseweg 1, NL-5621 BA Eindhoven (NL).
- (72) Inventors; and
- (75) Inventors/Applicants (for US only): OP DE BEECK, Marc, J., R. [BE/BE]; c/o Prof. Holstlaan 6, NL-5656 AA Eindhoven (NL). ERNST, Fabian, E. [DE/NL]; c/o Prof. Holstlaan 6, NL-5656 AA Eindhoven (NL).
- (74) Agent: GROENENDAAL, Antonius, W., M.; Prof. Holstlaan 6, NL-5656 AA Eindhoven (NL).
- (81) Designated States (unless otherwise indicated, for every kind of national protection available): AE, AG, AL, AM, AT, AU, AZ, BA, BB, BG, BR, BW, BY, BZ, CA, CH, CN, CO, CR, CU, CZ, DE, DK, DM, DZ, EC, EE, EG, ES, FI, GB, GD, GE, GH, GM, HR, HU, ID, IL, IN, IS, JP, KE, KG, KP, KR, KZ, LC, LK, LR, LS, LT, LU, LV, MA, MD, MG, MK, MN, MW, MX, MZ, NA, NI, NO, NZ, OM, PG, PH, PL, PT, RO, RU, SC, SD, SE, SG, SK, SL, SY, TJ, TM, TN, TR, TT, TZ, UA, UG, US, UZ, VC, VN, YU, ZA, ZM, ZW.
- (84) Designated States (unless otherwise indicated, for every kind of regional protection available): ARIPO (BW, GH, GM, KE, LS, MW, MZ, NA, SD, SL, SZ, TZ, UG, ZM, ZW), Eurasian (AM, AZ, BY, KG, KZ, MD, RU, TJ, TM), European (AT, BE, BG, CH, CY, CZ, DE, DK, EE, ES, FI, FR, GB, GR, HU, IE, IT, LU, MC, NL, PL, PT, RO, SE, SI, SK, TR), OAPI (BF, BJ, CF, CG, CI, CM, GA, GN, GQ, GW, ML, MR, NE, SN, TD, TG).

Declaration under Rule 4.17:

— as to applicant's entitlement to apply for and be granted a patent (Rule 4.17(ii)) for the following designations AE, AG, AL, AM, AT, AU, AZ, BA, BB, BG, BR, BW, BY, BZ,

[Continued on next page]

(54) Title: MULTI-VIEW IMAGE GENERATION

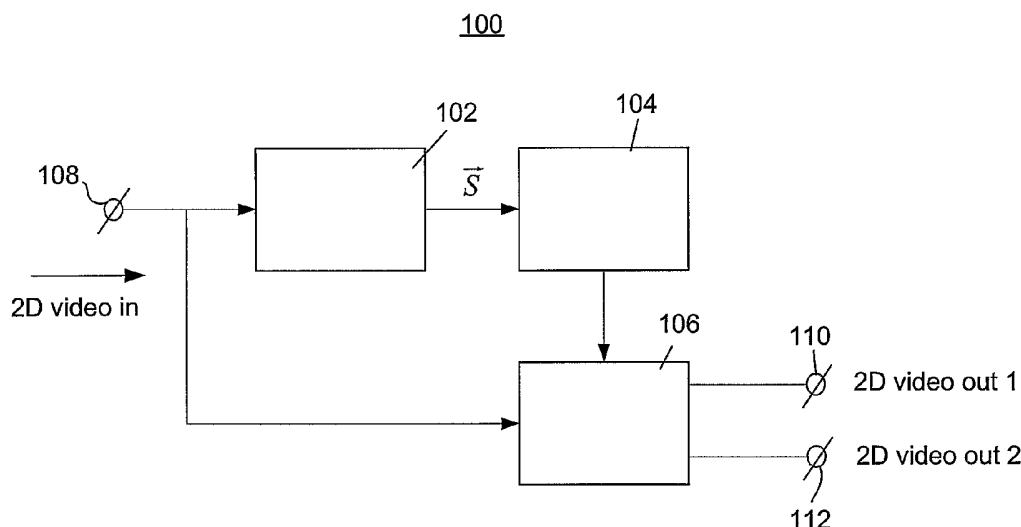

(57) Abstract: A multi-view image generation unit (100) for generating a multi-view image on basis of an input image is disclosed. The generation unit (100) comprises: edge detection means (102) for detecting an edge in the input image; depth generation means (104) for generating a depth map for the input image on basis of the edge, a first group of elements of the depth map corresponding to the edge having a first depth value, related to a viewer of the multi-view image, and a second group of elements of the depth map corresponding to a region of the input image, being located adjacent to the edge, having a second depth value, related to the viewer of the multi-view image, the first value being less than the second value; and rendering means (106) for rendering the multi-view image on basis of the input image and the depth map.

WO 2005/013623 A1



CA, CH, CN, CO, CR, CU, CZ, DE, DK, DM, DZ, EC, EE, EG, ES, FI, GB, GD, GE, GH, GM, HR, HU, ID, IL, IN, IS, JP, KE, KG, KP, KR, KZ, LC, LK, LR, LS, LT, LU, LV, MA, MD, MG, MK, MN, MW, MX, MZ, NA, NI, NO, NZ, OM, PG, PH, PL, PT, RO, RU, SC, SD, SE, SG, SK, SL, SY, TJ, TM, TN, TR, TT, TZ, UA, UG, UZ, VC, VN, YU, ZA, ZM, ZW, ARIPO patent (BW, GH, GM, KE, LS, MW, MZ, NA, SD, SL, SZ, TZ, UG, ZM, ZW), Eurasian patent (AM, AZ, BY, KG, KZ, MD, RU, TJ, TM), European patent (AT, BE, BG, CH, CY, CZ, DE, DK, EE, ES, FI, FR, GB, GR, HU, IE,

IT, LU, MC, NL, PL, PT, RO, SE, SI, SK, TR), OAPI patent (BF, BJ, CF, CG, CI, CM, GA, GN, GQ, GW, ML, MR, NE, SN, TD, TG)

Published:

— with international search report

For two-letter codes and other abbreviations, refer to the "Guidance Notes on Codes and Abbreviations" appearing at the beginning of each regular issue of the PCT Gazette.

Multi-view image generation

The invention relates to a multi-view image generation unit for generating a multi-view image on basis of an input image.

The invention further relates to an image processing apparatus comprising:

- receiving means for receiving a signal corresponding to an input image; and
- 5 - such a multi-view image generation unit for generating a multi-view image on basis of the input image.

The invention further relates to a method of generating a multi-view image on basis of an input image.

The invention further relates to a computer program product to be loaded by a
10 computer arrangement, comprising instructions to generate a multi-view image on basis of an input image, the computer arrangement comprising processing means and a memory.

In order to generate a 3D impression on a multi-view display device, images
15 from different virtual view points have to be rendered. This requires either multiple input views or some 3D or depth information to be present. This depth information can be either recorded, generated from multiview camera systems or generated from conventional 2D video material. For generating depth information from 2D video several types of depth cues can be applied: such as structure from motion, focus information, geometric shapes and
20 dynamic occlusion. The aim is to generate a dense depth map, i.e. per pixel a depth value. This depth map is subsequently used in rendering a multi-view image to give the viewer a depth impression. In the article "Synthesis of multi viewpoint images at non-intermediate positions" by P.A. Redert, E.A. Hendriks, and J. Biemond, in Proceedings of International Conference on Acoustics, Speech, and Signal Processing, Vol. IV, ISBN 0-8186-7919-0, pages 2749-2752, IEEE Computer Society, Los Alamitos, California, 1997 a method of
25 extracting depth information and of rendering a multi-view image on basis of the input image and the depth map are disclosed.

A disadvantage of the cited method is that often the depth map creation does not result in appropriate results, eventually resulting in unsatisfying depth impression.

It is an object of the invention to provide a multi-view image generation unit of the kind described in the opening paragraph which is arranged to render multi-view images with perceptually convincing depth impression on basis of relatively limited depth information.

This object of the invention is achieved in that the generation unit comprises:

- edge detection means for detecting an edge in the input image;
- depth map generation means for generating a depth map for the input image on basis of the edge, a first group of elements of the depth map corresponding to the edge having a first depth value, related to a viewer of the multi-view image, and a second group of elements of the depth map corresponding to a region of the input image, being located adjacent to the edge, having a second depth value, related to the viewer of the multi-view image, the first value being less than the second value; and
- rendering means for rendering the multi-view image on basis of the input image and the depth map.

As a consequence, the performed rendering of the multi-view image is in such a way that an edge is perceived as being closer to the viewer than the surrounding area, i.e. a depth difference on an edge is created. From a human perception point of view the edge appears to belong to a foreground object. So, locally the depth ordering seems such that the foreground object is indeed in front of the background. The inventors have observed that human perception then integrates this very limited and partial depth information to a complete depth impression.

It should be noted that an edge is not necessarily mean a transition of 1 pixel wide. It might be a soft-edge extending over a number of pixels.

In an embodiment of the multi-view image generation unit according to the invention the edge detection means are arranged to detect the edge by computing pixel value differences between first pixel values of the input image and respective second pixel values of a second input image, the input image and the second input image belonging to a sequence of video images. Detecting an edge on basis of subtracting subsequent images of a sequence of video images is relatively easy. An advantage of this embodiment is that a real-time implementation can be realized with relatively simple computing resources. The pixel values represent visible information like color or luminance.

In an embodiment of the multi-view image generation unit according to the invention, being arranged to detect the edge by computing pixel value differences, the first depth value is a function of a first one of the pixel value differences. In other words, the computed pixel value difference is used to determine the depth value. Preferably, the
5 computed pixel value difference is proportional to the depth value. Optionally, filtering is applied on the intermediate result of the computation of pixel value differences. The filtering might include spatial, temporal or spatio-temporal low-pass filtering. Alternatively, a threshold is used to filter out pixel value differences which are relatively low. These relatively low pixel value differences are then interpreted as noise.

10 In an embodiment of the multi-view image generation unit according to the invention, the edge detection means are arranged to detect the edge on basis of a motion vector field being computed on basis of the input image and a second input image, the input image and the second input image belonging to a sequence of video images. Preferably, the edge detection means are arranged to detect the edge by means of computing motion vector
15 differences of neighboring motion vectors of the motion vector field. Computing motion vector fields is a common technique known for e.g. video compression, de-interlacing or temporal up-conversion. Typically, discontinuities in a motion vector field, i.e. relatively large differences between adjacent motion vectors of the motion vector field correspond with borders of moving objects in the scene being captured, hence to relevant edges. An advantage
20 of this embodiment according to the invention is that it is arranged to discriminate between different type of edges: edges belonging to substantially stationary objects and edges belonging to moving objects. Especially, the latter type of edges are relevant because these edges typically correspond to foreground objects.

In an embodiment of the multi-view image generation unit according to the
25 invention, being arranged to detect the edge on basis of a motion vector field, the first depth value is a function of a first one of the motion vector differences. In other words, the computed motion vector difference is used to determine the depth value. Preferably, the computed motion vector differences is proportional to the depth value.

It is a further object of the invention to provide an image processing apparatus
30 comprising a multi-view image generation unit of the kind described in the opening paragraph which is arranged to render multi-view images with perceptually convincing depth impression on basis of relatively limited depth information.

This object of the invention is achieved in that the generation unit comprises:

- edge detection means for detecting an edge in the input image;

- depth map generation means for generating a depth map for the input image on basis of the edge, a first group of elements of the depth map corresponding to the edge having a first depth value, related to a viewer of the multi-view image, and a second group of elements of the depth map corresponding to a region of the input image, being located adjacent to the edge, having a second depth value, related to the viewer of the multi-view image, the first value being less than the second value; and
- rendering means for rendering the multi-view image on basis of the input image and the depth map.

Optionally, the image processing apparatus further comprises a multi-view display device for displaying the multi-view image.

It is a further object of the invention to provide a method of the kind described in the opening paragraph, to render multi-view images with perceptually convincing depth impression on basis of relatively limited depth information.

This object of the invention is achieved in that the method comprises:

- detecting an edge in the input image;
- generating a depth map for the input image on basis of the edge, a first group of elements of the depth map corresponding to the edge having a first depth value, related to a viewer of the multi-view image, and a second group of elements of the depth map corresponding to a region of the input image, being located adjacent to the edge, having a second depth value, related to the viewer of the multi-view image, the first value being less than the second value; and
- rendering the multi-view image on basis of the input image and the depth map.

It is a further object of the invention to provide a computer program product of the kind described in the opening paragraph, to render multi-view images with perceptually convincing depth impression on basis of relatively limited depth information.

This object of the invention is achieved in that the computer program product, after being loaded, provides said processing means with the capability to carry out:

- detecting an edge in the input image;
- generating a depth map for the input image on basis of the edge, a first group of elements of the depth map corresponding to the edge having a first depth value, related to a viewer of the multi-view image, and a second group of elements of the depth map corresponding to a region of the input image, being located adjacent to the edge, having a second depth value, related to the viewer of the multi-view image, the first value being less than the second value; and

- rendering the multi-view image on basis of the input image and the depth map.
Modifications of the multi-view image generation unit and variations thereof may correspond to modifications and variations thereof of the image processing apparatus, the method and the computer program product, being described.

5

These and other aspects of multi-view image generation unit, of the image processing apparatus, of the method and of the computer program product, according to the invention will become apparent from and will be elucidated with respect to the
10 implementations and embodiments described hereinafter and with reference to the accompanying drawings, wherein:

Fig. 1 schematically shows an embodiment of the multi-view image generation unit according to the invention;

15 Fig. 2 schematically shows another embodiment of the multi-view image generation unit according to the invention;

Fig. 3 schematically shows an input image of a sequence of video images;

Fig. 4A schematically shows a depth map based on color differences between subsequent input images;

Fig. 4B schematically shows a depth map based on motion discontinuities;

20 Fig. 5A schematically shows a first function for depth assignment to edges;

Fig. 5B schematically shows a second function for depth assignment to edges;

Fig. 5C schematically shows a third function for depth assignment to edges;

and

25 Fig. 6 schematically shows an embodiment of the image processing apparatus according to the invention.

Same reference numerals are used to denote similar parts throughout the figures.

30 Fig. 1 schematically shows an embodiment of the multi-view image generation unit 100 according to the invention. The multi-view image generation unit 100 is arranged to generate a sequence of multi-view images on basis of a sequence of video images. Fig. 3 schematically shows an input image of the sequence of video images. The multi-view image generation unit 100 is provided with a stream of video images at the input connector 108 and provides two correlated streams of video images at the output connectors 110 and 112,

respectively. These two correlated streams of video images are to be provided to a multi-view display device which is arranged to visualize a first series of views on basis of the first one of the correlated streams of video images and to visualize a second series of views on basis of the second one of the correlated streams of video images. If a user observes the first series of views by his left eye and the second series of views by his right eye he notices a 3D impression. It might be that the first one of the correlated streams of video images corresponds to the sequence of video images as received and that the second one of the correlated streams of video images is rendered on basis of the sequence of video images as received. Preferably, both streams of video images are rendered on basis of the sequence of video images image as received. The rendering is e.g. as described in the article "Synthesis of multi viewpoint images at non-intermediate positions" by P.A. Redert, E.A. Hendriks, and J. Biemond, in Proceedings of International Conference on Acoustics, Speech, and Signal Processing, Vol. IV, ISBN 0-8186-7919-0, pages 2749-2752, IEEE Computer Society, Los Alamitos, California, 1997. Alternatively, the rendering is as described in "High-quality images from 2.5D video", by R.P. Berretty and F.E. Ernst, in Proceedings Eurographics, Granada, 2003, Short Note 124.

The multi-view image generation unit 100 comprises:

- an edge detection unit 102 for detecting edges in input images;
- a depth map generation unit 104 for generating depth maps for the respective input images on basis of the detected edges; and
- a rendering unit 106 for rendering the multi-view images on basis of the input images and the respective depth maps.

Detecting edges might be based on spatial high-pass filtering of individual input images. However, the edges are preferably detected on basis of mutually comparing multiple input images, in particular computing pixel value differences of subsequent images of the sequence of video images. A first example of the computation of pixel value differences $S(x, y, n)$ is given in Equation 1:

$$S(x, y, n) = |I(x, y, n) - I(x, y, n - 1)| \quad (1)$$

with, $I(x, y, n)$ the luminance value of a pixel with coordinates x and y of image at time n .

Alternatively, the pixel value differences $S(x, y, n)$ are computed on basis of color values:

$$S(x, y, n) = |C(x, y, n) - C(x, y, n - 1)| \quad (2)$$

with, $C(x, y, n)$ a color value of a pixel with coordinates x and y of image at time n . In

Equation 3 a further alternative is given for the computation of pixel value differences

$S(x, y, n)$ based on the three different color components R (Red) G (Green) and B (Blue).

$$S(x, y, n) = \max(|R(x, y, n) - R(x, y, n-1)|, |G(x, y, n) - G(x, y, n-1)|, |B(x, y, n) - B(x, y, n-1)|) \quad (3)$$

5 Optionally, the pixel value difference signal \vec{S} is filtered by clipping all pixel value differences which are below a predetermined threshold, to a constant e.g. zero.

Optionally, a morphologic filter operation is applied to remove all spatially small edges.

Morphologic filters are common non-linear image processing units. See for instance the article "Low-level image processing by max-min filters" by P.W. Verbeek, H.A. Vrooman

10 and L.J. van Vliet, in "Signal Processing", vol. 15, no. 3, pp. 249-258, 1988.

After the computation of the filtered pixel value difference signal \vec{S}_F the depth map is determined. This is specified in Equation 4:

$$D(x, y, n) = F(S_F(x, y, n)) \quad (4)$$

with $D(x, y, n)$ the depth value of a pixel with coordinates x and y of image at time n and

15 the function $F(j)$ being a linear or non-linear transformation of a pixel value difference

$S_F(x, y, n)$ into a depth value $D(x, y, n)$. This function $F(j)$ might be a simple multiplication of the pixel value difference $S_F(x, y, n)$ with a predetermined constant:

$$D(x, y, n) = \alpha \cdot S_F(x, y, n) \quad (5)$$

Alternatively, the function $F(j)$ corresponds to a multiplication of the pixel value difference

20 $S_F(x, y, n)$ with a weighting factor $W(i)$ which relates to a spatial distance i between the pixel under consideration and a second pixel in a spatial neighborhood of the pixel under consideration, having a local maximum value. It is assumed that the second pixel is located in the center of the edge.

$$D(x', y', n) = W(x, y, x', y') * S_F(x, y, n) \quad (6)$$

25 Fig. 5A schematically shows a suitable function for depth assignment to edges, i.e. the weighting factor $W(i)$ as function of the spatial distance i .

The result of the operations as described above is that a first group of elements of a particular depth map corresponding to the edge have a first depth value, related to a viewer of the multi-view image, and a second group of elements of the depth map

30 corresponding to a region of a particular input image, being located adjacent to the edge, have a second depth value, related to the viewer of the multi-view image, the first value being less than the second value. Or in other words, the elements of the depth map corresponding to

the edge have values which represent a smaller distance to the viewer than the other elements of the depth map.

Fig. 4A schematically shows an example of a depth map based on color differences between subsequent input images. This depth map is determined as described above in Equation 2 and 5, however without the filtering.

The edge detection unit 102, the depth map generation unit 104 and the rendering unit 106 may be implemented using one processor. Normally, these functions are performed under control of a software program product. During execution, normally the software program product is loaded into a memory, like a RAM, and executed from there. The program may be loaded from a background memory, like a ROM, hard disk, or magnetically and/or optical storage, or may be loaded via a network like Internet. Optionally an application specific integrated circuit provides the disclosed functionality.

Fig. 2 schematically shows another embodiment of the multi-view image generation unit 200 according to the invention. The multi-view image generation unit 200 is arranged to generate a sequence of multi-view images on basis of a sequence of video images. The multi-view image generation unit 200 is provided with a stream of video images at the input connector 108 and provides two correlated streams of video images at the output connectors 110 and 112, respectively. The multi-view image generation unit 200 comprises:

- a motion estimation unit 202 for computing motion vector fields of the input images;
- an edge detection unit 102 for detecting edges in the input images on basis of the respective motion vector fields;
- a depth map generation unit 104 for generating depth maps for the respective input images on basis of the detected edges; and
- a rendering unit 106 for rendering the multi-view images on basis of the input images and the respective depth maps.

The motion estimation unit 202 is e.g. as specified in the article "True-Motion Estimation with 3-D Recursive Search Block Matching" by G. de Haan et. al. in IEEE Transactions on circuits and systems for video technology, vol. 3, no. 5, October 1993, pages 368-379.

The edge detection unit 102 is provided with motion vector fields as computed by the motion estimation unit 202. The edge detection unit 102 is arranged to determine motion vector field discontinuities. That means that it is arranged to detect regions in the motion vector fields having a relatively large motion vector contrast. These regions

correspond with edges in the corresponding image. Optionally the edge detection unit 102 is also provided with pixel values, i.e. color and or luminance values of the input images. By appropriately combining the various inputs segments in the image are achieved. This processing is also described by F. Ernst in "2D-to-3D video conversion based on time-consistent segmentation", in Proceedings of the ICOB (Imersive Communication and Broadcast Systems) workshop, Heinrich-Hertz-Institut, Berlin, January 2003. Besides coordinates of the detected edges of the segments in the images, also topological information of the segments may be provided by the edge detection unit 102. Hence, it may be known which side of the edges belongs to a foreground object and which side of the edge belongs to background.

After the edge detection, the assignment of depth values is performed. Preferably, the assignment of depth values is based on weighting factors $W(i)$ as depicted in the Figs. 5B and 5C. In these Figs. 5B and 5C it is assumed that the left part corresponds to the foreground. Fig. 5B shows asymmetric assignment; the depth jump is biased towards the foreground and Fig. 5C shows skewed assignment; the depth jump falls off more quickly in the background. While symmetric assignment, as depicted in Fig. 5A of the depth around an edge seems to be sufficient for adequate perception, it is preferred that if there is additional depth information, from any other depth cue, this is applied for the assignment of depth values to an edge. The assignment of depth values is preferably slightly biased such that the foreground side of the edge is rendered somewhat more to the front than the background side of the edge. As said above, the edge detection unit 102 is arranged to provide information about the topology of the segments. Hence, it is known which side of the edge belongs to the foreground and which side belongs to the background. Fig. 4B schematically shows a depth map based on motion discontinuities as provided by the depth map generation unit 104 of this embodiment according to the invention.

The motion estimation unit 202, the edge detection unit 102, the depth map generation unit 104 and the rendering unit 106 may be implemented using one processor.

To summarize, the multi-view image generation units 100 and 200 are arranged to render multiple-view images, by means of detecting edges in input images, which are good candidates for depth discontinuities and rendering these images in such a way that the edges are perceived as being closer to the viewer than surrounding areas.

As the depth assignment is primarily based on edge detection it is easy and stable to implement. Especially because the edge detection is relatively easy: based on color, luminance, texture or motion. Preferably, the edges are tracked through time, for instance

through time-consistent segmentation, to have the depth assignment per edge more stable over time.

Fig. 6 schematically shows an embodiment of the image processing apparatus 600 according to the invention, comprising:

- 5 - a receiving unit 602 for receiving a video signal representing input images;
 - a multi-view image generation unit 604 for generating multi-view images on basis of the received input images, as described in connection with any of the Figs. 1 and 2; and
 - a multi-view display device 606 for displaying the multi-view images as
- 10 provided by the multi-view image generation unit 604.

The video signal may be a broadcast signal received via an antenna or cable but may also be a signal from a storage device like a VCR (Video Cassette Recorder) or Digital Versatile Disk (DVD). The signal is provided at the input connector 610. The image processing apparatus 600 might e.g. be a TV. Alternatively the image processing apparatus

15 600 does not comprise the optional display device but provides the output images to an apparatus that does comprise a display device 606. Then the image processing apparatus 600 might be e.g. a set top box, a satellite-tuner, a VCR player, a DVD player or recorder. Optionally the image processing apparatus 600 comprises storage means, like a hard-disk or means for storage on removable media, e.g. optical disks. The image processing apparatus

20 600 might also be a system being applied by a film-studio or broadcaster.

It should be noted that the above-mentioned embodiments illustrate rather than limit the invention and that those skilled in the art will be able to design alternative embodiments without departing from the scope of the appended claims. In the claims, any reference signs placed between parentheses shall not be constructed as limiting the claim.

25 The word 'comprising' does not exclude the presence of elements or steps not listed in a claim. The word "a" or "an" preceding an element does not exclude the presence of a plurality of such elements. The invention can be implemented by means of hardware comprising several distinct elements and by means of a suitable programmed computer. In the unit claims enumerating several means, several of these means can be embodied by one

30 and the same item of hardware.

CLAIMS:

1. A multi-view image generation unit (100, 200) for generating a multi-view image on basis of an input image, the generation unit comprising:
 - edge detection means (102) for detecting an edge in the input image;
 - depth map generation means (104) for generating a depth map for the input
5 image on basis of the edge, a first group of elements of the depth map corresponding to the edge having a first depth value, related to a viewer of the multi-view image, and a second group of elements of the depth map corresponding to a region of the input image, being located adjacent to the edge, having a second depth value, related to the viewer of the multi-view image, the first value being less than the second value; and
 - 10 - rendering means (106) for rendering the multi-view image on basis of the input image and the depth map.

2. A multi-view image generation unit (100) as claimed in claim 1, wherein the edge detection means (102) are arranged to detect the edge by computing pixel value
15 differences between first pixel values of the input image and respective second pixel values of a second input image, the input image and the second input image belonging to a sequence of video images.

3. A multi-view image generation unit (100) as claimed in claim 2, wherein the
20 first pixel values represent one of color and luminance.

4. A multi-view image generation unit (100) as claimed in claim 2, wherein the first depth value is a function of a first one of the pixel value differences.

- 25 5. A multi-view image generation unit (200) as claimed in claim 1, wherein the edge detection means (102) are arranged to detect the edge on basis of a motion vector field being computed on basis of the input image and a second input image, the input image and the second input image belonging to a sequence of video images.

6. A multi-view image generation unit (200) as claimed in claim 5, wherein the edge detection means (102) are arranged to detect the edge by means of computing motion vector differences of neighboring motion vectors of the motion vector field.
- 5 7. A multi-view image generation unit (200) as claimed in claim 6, wherein the first depth value is a function of a first one of the motion vector differences.
8. An image processing apparatus (600) comprising:
- receiving means (602) for receiving a signal corresponding to an input image;
- 10 and
- a multi-view image generation unit (604) for generating a multi-view image on basis of the input image, as claimed in claim 1.
9. An image processing apparatus (600) as claimed in claim 8, further
- 15 comprising a multi-view display device (606) for displaying the multi-view image.
10. A method of generating a multi-view image on basis of an input image, the method comprising:
- detecting an edge in the input image;
- 20 - generating a depth map for the input image on basis of the edge, a first group of elements of the depth map corresponding to the edge having a first depth value, related to a viewer of the multi-view image, and a second group of elements of the depth map corresponding to a region of the input image, being located adjacent to the edge, having a second depth value, related to the viewer of the multi-view image, the first value being less
- 25 than the second value; and
- rendering the multi-view image on basis of the input image and the depth map.
11. A computer program product to be loaded by a computer arrangement, comprising instructions to generate a multi-view image on basis of an input image, the
- 30 computer arrangement comprising processing means and a memory, the computer program product, after being loaded, providing said processing means with the capability to carry out:
- detecting an edge in the input image;
 - generating a depth map for the input image on basis of the edge, a first group of elements of the depth map corresponding to the edge having a first depth value, related to

a viewer of the multi-view image, and a second group of elements of the depth map corresponding to a region of the input image, being located adjacent to the edge, having a second depth value, related to the viewer of the multi-view image, the first value being less than the second value; and

- 5 - rendering the multi-view image on basis of the input image and the depth map

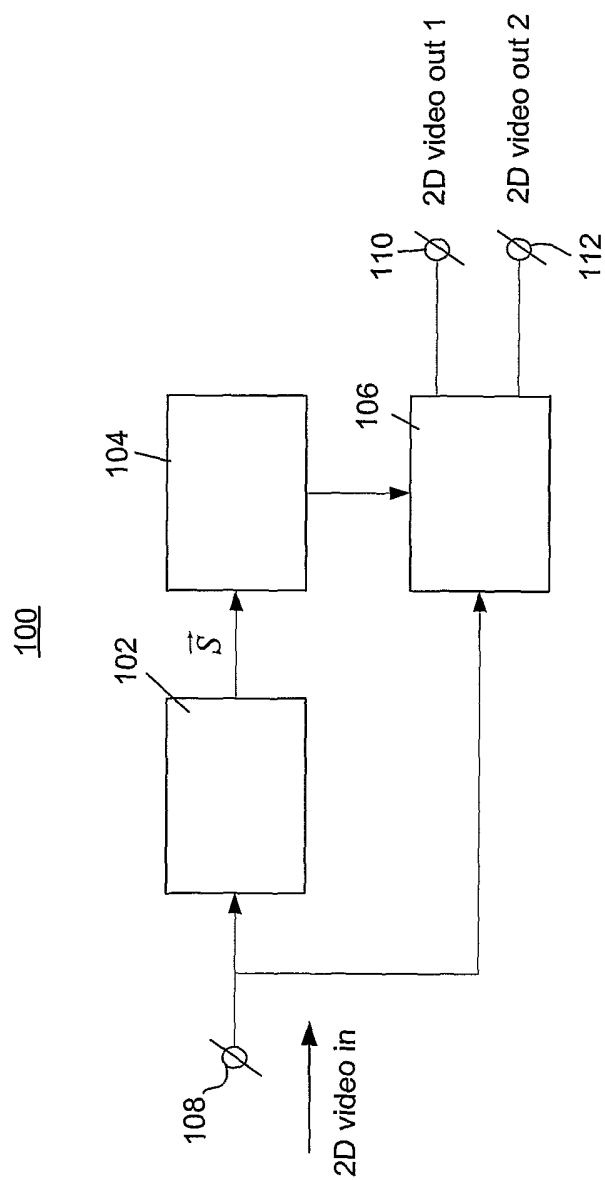

FIG. 1

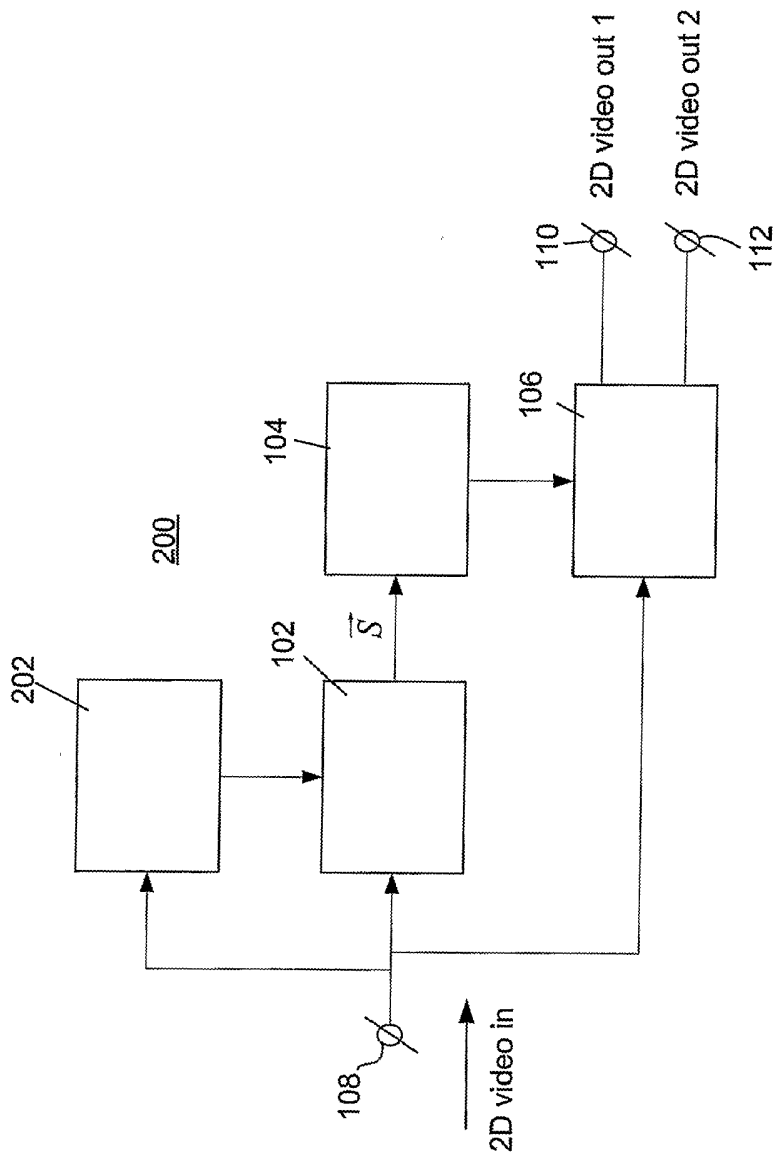

FIG. 2

3/7



FIG. 3

4/7

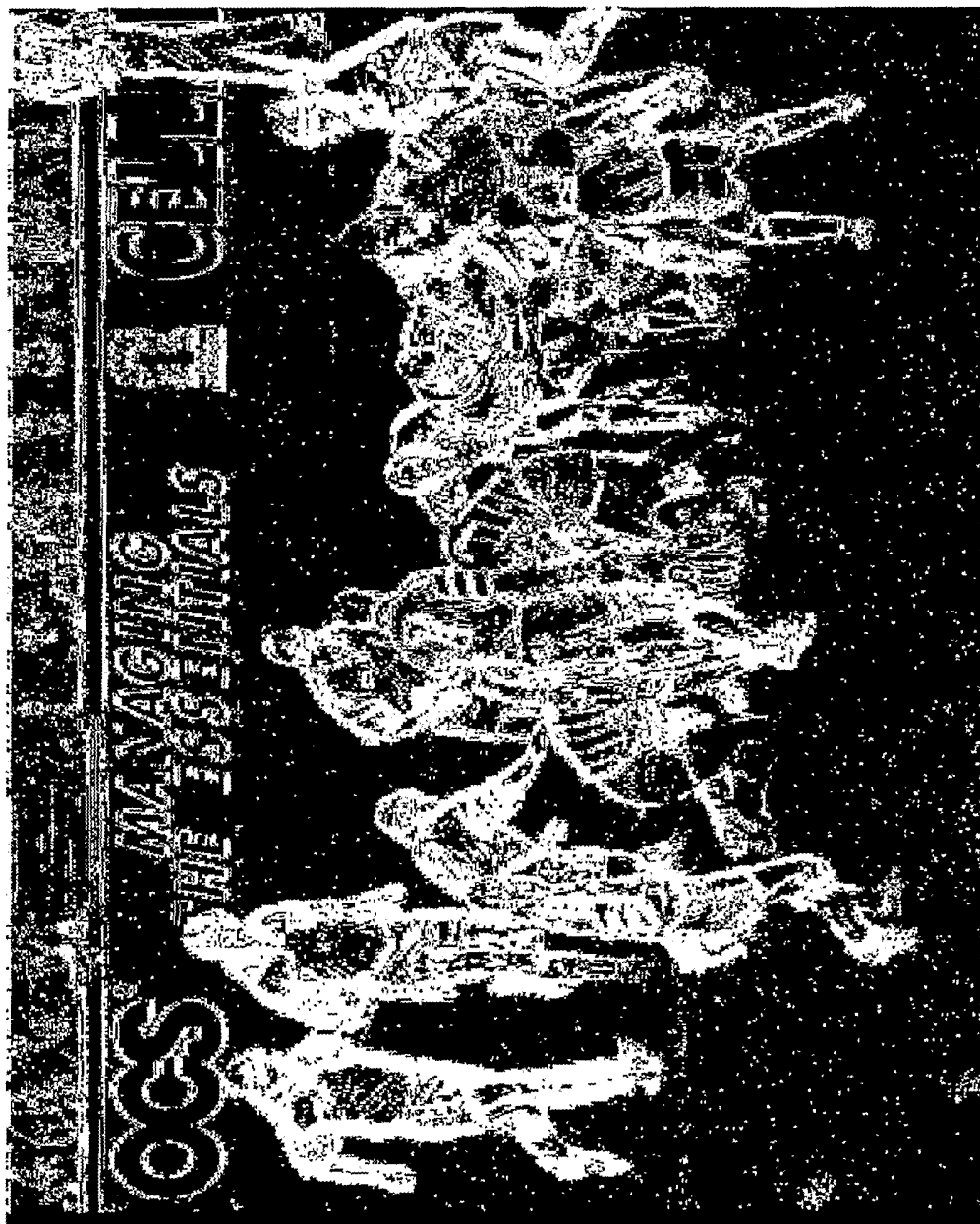

FIG. 4A

5/7



FIG. 4B

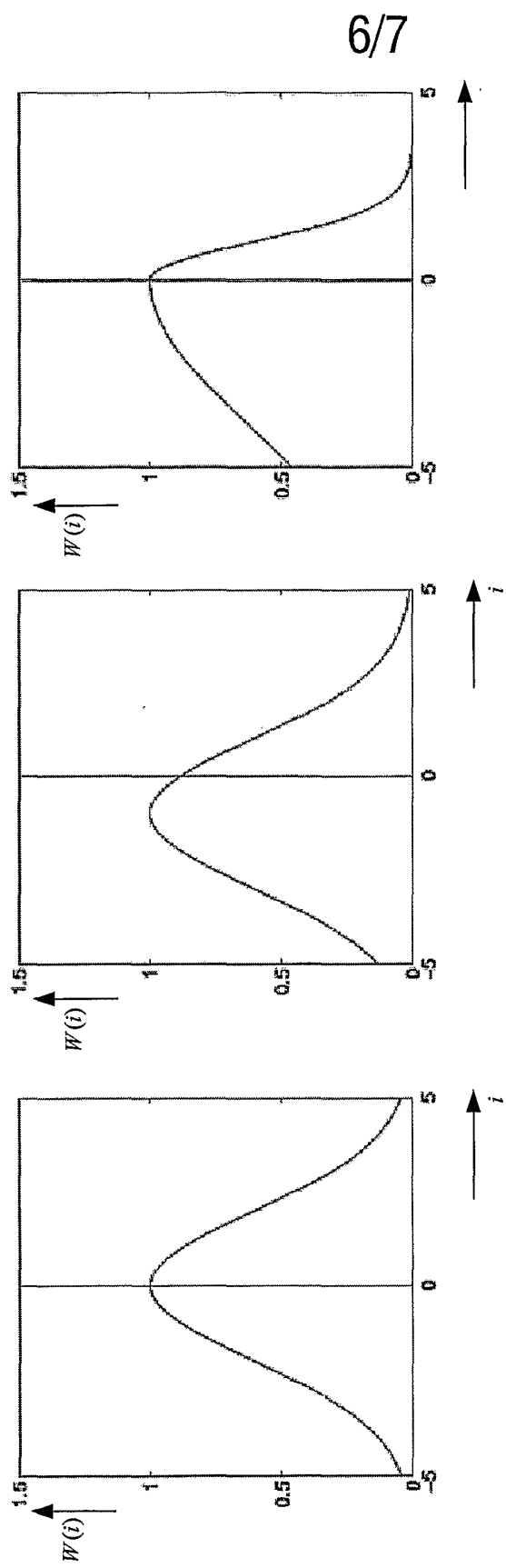

FIG. 5C

FIG. 5B

FIG. 5A

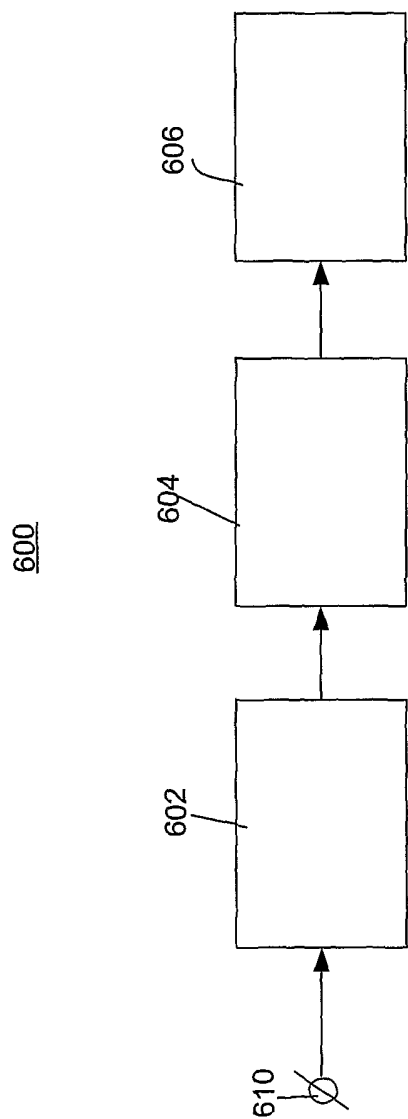

FIG. 6

INTERNATIONAL SEARCH REPORT

IB2004/051315

A. CLASSIFICATION OF SUBJECT MATTER
 IPC 7 H04N13/00 H04N7/26 G06T15/10 G06T15/20 G06T5/00

According to International Patent Classification (IPC) or to both national classification and IPC

B. FIELDS SEARCHED
 Minimum documentation searched (classification system followed by classification symbols)
 IPC 7 H04N G06T

Documentation searched other than minimum documentation to the extent that such documents are included in the fields searched

Electronic data base consulted during the international search (name of data base and, where practical, search terms used)
 EPO-Internal

C. DOCUMENTS CONSIDERED TO BE RELEVANT

Category °	Citation of document, with indication, where appropriate, of the relevant passages	Relevant to claim No.
X	WO 99/30280 A (DYNAMIC DIGITAL DEPTH RESEARCH ; HARMAN PHILIP VICTOR (AU)) 17 June 1999 (1999-06-17)	1,2,4, 10,11
Y	abstract; claim 1; figures 2b,2c page 1, lines 19-25 page 3, lines 16-20 page 5, lines 21-28 page 7, lines 9-12 page 9, line 31 - page 10, line 4	5-7
X	US 6 201 566 B1 (FUJIHARA KAZUHIKO ET AL) 13 March 2001 (2001-03-13) abstract; claims 1,3; figure 3 column 3, lines 1-10,27-39 column 5, lines 34-65 column 10, line 53 - column 11, line 12 column 12, lines 40-51	1,3,8-11
	----- -/--	

Further documents are listed in the continuation of box C. Patent family members are listed in annex.

° Special categories of cited documents :

A document defining the general state of the art which is not considered to be of particular relevance	*T* later document published after the international filing date or priority date and not in conflict with the application but cited to understand the principle or theory underlying the invention
E earlier document but published on or after the international filing date	*X* document of particular relevance; the claimed invention cannot be considered novel or cannot be considered to involve an inventive step when the document is taken alone
L document which may throw doubts on priority claim(s) or which is cited to establish the publication date of another citation or other special reason (as specified)	*Y* document of particular relevance; the claimed invention cannot be considered to involve an inventive step when the document is combined with one or more other such documents, such combination being obvious to a person skilled in the art.
O document referring to an oral disclosure, use, exhibition or other means	*&* document member of the same patent family
P document published prior to the international filing date but later than the priority date claimed	

Date of the actual completion of the international search 4 November 2004	Date of mailing of the international search report 12/11/2004
---	---

Name and mailing address of the ISA European Patent Office, P.B. 5818 Patentlaan 2 NL - 2280 HV Rijswijk Tel. (+31-70) 340-2040, Tx. 31 651 epo nl, Fax: (+31-70) 340-3016	Authorized officer Cakiroglu, S
--	---

INTERNATIONAL SEARCH REPORT

IB2004/051315

C.(Continuation) DOCUMENTS CONSIDERED TO BE RELEVANT		
Category °	Citation of document, with indication, where appropriate, of the relevant passages	Relevant to claim No.
X	US 6 031 564 A (MA KELVIN ET AL) 29 February 2000 (2000-02-29) abstract; claim 1 column 2, lines 10-31,45-51 column 4, lines 20-47 column 4, line 50 - column 5, line 34 -----	1,10,11
X	US 6 477 267 B1 (RICHARDS ANGUS DUNCAN) 5 November 2002 (2002-11-05) abstract; claims 2,19 paragraphs '0022! - '0028!, '0102!, '0111!, '0112! -----	1,10,11
X	WO 02/095680 A (ERNST FABIAN E ; WILINSKI PIOTR (NL); KONINKL PHILIPS ELECTRONICS NV () 28 November 2002 (2002-11-28) abstract; claims 5-8,14 page 1, lines 4-15 page 3, lines 4-23 page 7, line 25 - page 8, line 16 -----	1,10,11
Y	WO 03/005727 A (KONINKL PHILIPS ELECTRONICS NV) 16 January 2003 (2003-01-16) abstract page 1, lines 15-22 page 3, lines 20-28 page 11, line 10 - page 12, line 7 page 12, lines 30,31 -----	5-7
A	PARDAS M: "Video object segmentation introducing depth and motion information" IMAGE PROCESSING, 1998. ICIP 98. PROCEEDINGS. 1998 INTERNATIONAL CONFERENCE ON CHICAGO, IL, USA 4-7 OCT. 1998, LOS ALAMITOS, CA, USA, IEEE COMPUT. SOC, US, 4 October 1998 (1998-10-04), pages 637-641, XP010308523 ISBN: 0-8186-8821-1 abstract paragraph '0004! -----	5-7
A	WO 99/12127 A (HARMAN PHILIP VICTOR ; XENOTECH RES PTY LTD (AU)) 11 March 1999 (1999-03-11) abstract page 2, line 22 - page 3, line 6 page 12, line 10 - page 17, line 10 -----	5-7

INTERNATIONAL SEARCH REPORT

IB2004/051315

Patent document cited in search report		Publication date	Patent family member(s)	Publication date
WO 9930280	A	17-06-1999	AU 738692 B2	27-09-2001
			AU 1647299 A	28-06-1999
			WO 9930280 A1	17-06-1999
			CA 2305735 A1	17-06-1999
			CN 1281569 T	24-01-2001
			EP 1044432 A1	18-10-2000
			ID 27878 A	03-05-2001
			JP 2001526477 T	18-12-2001
			US 2004032488 A1	19-02-2004
			US 2004032980 A1	19-02-2004
US 6201566	B1	13-03-2001	JP 10276455 A	13-10-1998
			CN 1201338 A	09-12-1998
US 6031564	A	29-02-2000	AU 8066898 A	08-02-1999
			WO 9903068 A1	21-01-1999
			US 6215516 B1	10-04-2001
US 6477267	B1	05-11-2002	AT 264527 T	15-04-2004
			AT 242950 T	15-06-2003
			AU 714759 B2	13-01-2000
			AU 1088497 A	17-07-1997
			WO 9724000 A1	03-07-1997
			CA 2241078 A1	03-07-1997
			CA 2435044 A1	03-07-1997
			CN 1209248 A ,B	24-02-1999
			DE 69628662 D1	17-07-2003
			DE 69628662 T2	29-04-2004
			DE 69632212 D1	19-05-2004
			DK 1187494 T3	10-05-2004
			EP 1187494 A2	13-03-2002
			EP 0868818 A1	07-10-1998
			HK 1010624 A1	03-10-2003
			JP 2000502234 T	22-02-2000
			PT 1187494 T	30-07-2004
US 2003007681 A1	09-01-2003			
WO 02095680	A	28-11-2002	CN 1463415 T	24-12-2003
			EP 1395949 A1	10-03-2004
			WO 02095680 A1	28-11-2002
			JP 2004520660 T	08-07-2004
			US 2004179739 A1	16-09-2004
WO 03005727	A	16-01-2003	EP 1407613 A1	14-04-2004
			WO 03005727 A1	16-01-2003
			US 2003007667 A1	09-01-2003
WO 9912127	A	11-03-1999	AU 8964598 A	22-03-1999
			WO 9912127 A1	11-03-1999
			CA 2302199 A1	11-03-1999
			CN 1278349 T	27-12-2000
			EP 1019873 A1	19-07-2000
			JP 2001515287 T	18-09-2001
			US 2002191841 A1	19-12-2002
			US 6496598 B1	17-12-2002