

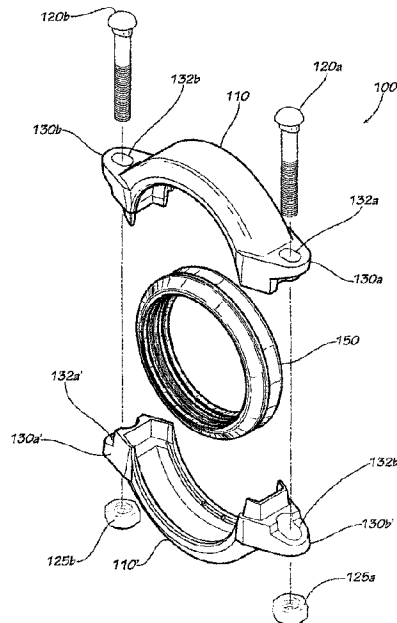

(22) **Date de dépôt/Filing Date:** 2012/05/07
(41) **Mise à la disp. pub./Open to Public Insp.:** 2013/07/20
(45) **Date de délivrance/Issue Date:** 2020/07/14
(62) **Demande originale/Original Application:** 3 020 608
(30) **Priorités/Priorities:** 2012/01/20 (US13/354,470);
2012/01/20 (US13/354,466); 2012/01/20 (US13/354,464);
2012/01/20 (US13/354,459)

(51) **Cl.Int./Int.Cl. F16J 15/10** (2006.01),
F16L 21/02 (2006.01), **F16L 21/06** (2006.01),
F16L 23/04 (2006.01), **F16L 25/04** (2006.01)
(72) **Inventeur/Inventor:**
BEAGEN, JOSEPH WILLIAM, JR., US
(73) **Propriétaire/Owner:**
ANVIL INTERNATIONAL, LLC, US
(74) **Agent:** RIDOUT & MAYBEE LLP

(54) **Titre : DISPOSITIF D'ACCOUPLMENT**
(54) **Title: COUPLING**



(57) **Abrégé/Abstract:**

A coupling includes at least one segment, each segment including at least one inner surface, at least one outer surface, at least two ends, and a fastener pad protruding proximate to each end, each fastener pad defining a fastener hole, each fastener hole having an axial length and a transverse length, wherein the transverse length is longer than the axial length; an annular gasket contacting the inner surface of at least one segment, the annular gasket including at least one sealing surface directed radially inwardly and an outer surface directed radially outwardly; and at least one fastener disposed within at least one fastener hole, each fastener including a head portion and a shaft portion, each shaft portion including at least one of a threaded portion, a shank portion, and a collar portion, wherein at least one portion of the shaft portion is sized to engage at least one fastener hole.

ABSTRACT

A coupling includes at least one segment, each segment including at least one inner surface, at least one outer surface, at least two ends, and a fastener pad protruding proximate to each end, each fastener pad defining a fastener hole, each fastener hole having an axial length and a transverse length, wherein the transverse length is longer than the axial length; an annular gasket contacting the inner surface of at least one segment, the annular gasket including at least one sealing surface directed radially inwardly and an outer surface directed radially outwardly; and at least one fastener disposed within at least one fastener hole, each fastener including a head portion and a shaft portion, each shaft portion including at least one of a threaded portion, a shank portion, and a collar portion, wherein at least one portion of the shaft portion is sized to engage at least one fastener hole.

COUPLING

FIELD

[0001]

[0002] This disclosure relates to piping. More specifically, this disclosure relates to pipe coupling.

BACKGROUND

[0003] Pipe elements such as pipes, valves, and meters typically are not made of one piece. Rather, such pipe elements are formed in finite lengths and must be joined. One way of joining such pipe elements is through the use of a coupling member. A sealing gasket is typically disposed in a coupling void of at least one coupling segment which is thereafter tightened around the pipe elements to be joined.

SUMMARY

[0004] Disclosed is a slip-on coupling including at least one segment, each segment including at least one inner surface, at least one outer surface, at least two ends, and a fastener pad protruding proximate to each end, each fastener pad defining a fastener hole, each fastener hole having an axial length and a transverse length, wherein the transverse length is longer than the axial length; an annular gasket contacting the inner surface of at least one segment, the annular gasket including at least one sealing surface directed radially inwardly and an outer surface directed radially outwardly; and at least one fastener disposed within at least one fastener hole, each fastener including a head portion and a shaft portion, each shaft portion including at least one of a threaded portion, a shank portion, and a collar portion, wherein at least one portion of the shaft portion is sized to engage at least one fastener hole

[0005] A coupling is disclosed including an annular gasket, the annular gasket including at least one sealing surface directed radially inwardly and an outer surface directed radially outwardly; at least one segment, each segment being approximately semi-circular and including at least one inner surface, at least one outer surface, and at least two ends, each segment including a fastener pad protruding proximate to each end, each fastener pad defining a fastener hole, each end including at least one of a tongue and a groove, each tongue protruding circumferentially from at least one end, each groove defined circumferentially in at least one end; and at least one fastener, wherein at least

one portion of a shaft portion of the fastener is sized to engage at least one fastener hole in at least one segment.

[0006] An annular gasket is disclosed including an annular body; a pair of sealing ribs each extending substantially radially inwardly from the annular body and having an innermost radial extent; and at least one center rib extending substantially radially inwardly from the annular body, the at least one center rib having an innermost radial extent closer to the annular body than the innermost radial extent of each of the pair of sealing ribs.

[0007] An annular gasket is disclosed including an annular body and a pair of sealing ribs extending substantially radially inward from the annular body, each sealing rib having a sealing ridge, the sealing ridge of each of the pair of sealing ribs having a sealing surface, wherein the sealing surface is about cylindrical at rest. Various implementations described in the present disclosure may include additional systems, methods, features, and advantages, which may not necessarily be expressly disclosed herein but will be apparent to one of ordinary skill in the art upon examination of the following detailed description and accompanying drawings. It is intended that all such systems, methods, features, and advantages be included within the present disclosure and protected by the accompanying claims.

DESCRIPTION OF THE FIGURES

[0008] The features and components of the following figures are illustrated to emphasize the general principles of the present disclosure and are not necessarily drawn to scale. Corresponding features and components throughout the figures may be designated by matching reference characters for the sake of consistency and clarity.

[0009] FIG. 1 is an exploded perspective view of a coupling in accord with one embodiment of the current disclosure.

[0010] FIG. 2 is an outer perspective view of a segment of the coupling of FIG. 1.

[0011] FIG. 3 is an inner perspective view of the segment of FIG. 2.

[0012] FIG. 4 is a cross-sectional view of the segment of FIG. 2.

[0013] FIG. 5 is a cross-sectional view of a gasket of the coupling of FIG. 1.

[0014] FIG. 6 is a side view of the coupling of FIG. 1 in an assembled and untightened position.

[0015] FIG. 7 is a side view of the coupling of FIG. 1 in an assembled and tightened position, including a cross-sectional view of pipe elements.

[0016] FIG. 8A is a cross-sectional view of the coupling of FIG. 1 before installation on pipe elements.

[0017] FIG. 8B is a cross-sectional view of the coupling of FIG. 1 during installation on pipe elements.

[0018] FIG. 8C is a cross-sectional view of the coupling of FIG. 1 during installation on pipe elements.

[0019] FIG. 8D is a cross-sectional view of the coupling of FIG. 1 during installation on pipe elements.

[0020] FIG. 8E is a cross-sectional view of the coupling of FIG. 1 after installation on pipe elements.

[0021] FIG. 9 is a cross-sectional view of the coupling taken in a plane indicated by line 9 in FIG. 6.

[0022] FIG. 10 is a partial cross-sectional view of the coupling of FIG. 1 assembled around pipe elements and in an untightened position.

[0023] FIG. 11 is a partial cross-sectional view of the coupling of FIG. 1 assembled around pipe elements and in a tightened position.

DETAILED DESCRIPTION

[0024] Disclosed is a pipe coupling and associated methods, systems, devices, and various apparatus.

The pipe coupling includes at least one segment, at least one tightening element, and at least one gasket. The pipe coupling is adapted to seal pipe elements in end-to-end relationship. It would be understood by one of skill in the art that the disclosed pipe coupling is described in but a few exemplary embodiments among many. No particular terminology or description should be considered limiting on the disclosure or the scope of any claims issuing therefrom.

[0025] One embodiment of a pipe coupling 100 is disclosed and described in FIG. 1. The pipe coupling 100 of the current embodiment includes two segments 110,110' although any number of segments 110 may be used in various embodiments. The current embodiment includes tightening elements or fasteners that are nut and bolt fasteners. Two bolts 120a,b are disposed to interact with nuts 125a,b in threaded engagement. Various types of tightening elements may be used in various embodiments, and the disclosure of bolts 120a,b, and nuts 125a,b should not be considered limiting. Fastener pads 130a,b protrude from segment 110 and fastener pads 130a',b' protrude from segment 110'. Fastener holes 132a,b,a',b' are defined in fastener pads 130a,b,a',b', respectively. In the current embodiment, the fastener holes 132a,b,a',b' are about centered within the fastener pads 130a,b,a',b', although they may be offset in various embodiments. Although the fastener pads 130a,b,a',b' and fastener holes 132a,b,a',b' are described in the current configuration, various locations and configurations of fastener pads 130a,b,a',b' and fastener holes 132a,b,a',b' are included in various embodiments. A gasket 150 is included with the pipe coupling 100. The gasket 150 of the current embodiment is annular and adapted to surround and to seal fluid piping, although various configurations will be included in various embodiments.

[0026] FIGs. 2, 3, and 4 show segment 110. In the current embodiment, segment 110' is substantially identical to segment 110. As seen in FIG. 2, each segment 110 includes two ends 203,207 and a segment body 210 disposed between the two ends 203,207. Each segment 110 in the current embodiment is about semicircular, although other configurations may be used in various

embodiments. Proximate each end 203,207 is a shoulder 213,217 protruding outwardly from the segment 110. Each shoulder 213,217 provides a connection point for a fastener which, in the current embodiment, is a bolt 120. Each shoulder 213,217 includes fastener holes 132a,b defined in fastener pads 130a,b.

[0027] Each segment body 210 includes a central portion 215 and at least one edge portion 225b (225a not shown in FIG. 2). In the current embodiment, the edge portions 225a,b are designed to interact with a groove in the pipe elements to be sealed and joined, although some embodiments may be designed to interact with non-grooved pipe elements.

[0028] As can be seen in FIG. 2, each fastener hole 132a,b includes a first linear extent or an axial length 233,237 and a second linear extent or transverse length 243,247. The axial lengths 233,237 and the transverse lengths 243,247 are measured at top surfaces 364,314 of the fastener pads 130a,b. These dimensions increase through the fastener pads 130a,b in the current embodiment because they are cast, and a draft angle is used in casting. In various embodiments, these dimensions may remain constant if, for example, the fastener holes 132a,b are made via a machining step. In the current embodiment, each fastener hole 132a,b is about ovular in shape, although other embodiments may include various shapes. The shape of the current embodiment of the fastener holes 132a,b provides interference with the bolts 120a,b to reduce rocking motion, as will be described later with reference to FIG. 9. Each segment 110 includes an outer surface 250 and an inner surface 260. A contact surface 262b (262a shown in FIG. 3) is included on the inside of each edge portion 225a,b. Also seen in FIG. 2 is a tongue 280, as will be described in more detail with reference to FIGs. 3, 4, and 6.

[0029] As seen more clearly in FIG. 3, the tongue 280 protrudes from the end 207 of the segment 110. The shoulder 217 can be seen protruding outwardly from the segment 110. In the current embodiment, the shoulder 217 includes a bottom surface 312 and a top surface 314. The bottom surface 312 and the top surface 314 are substantially parallel in the current embodiment and are angled in order to ensure proper alignment upon deformable tightening of the pipe coupling 100, as will be discussed later with reference to FIG. 4. However, in some embodiments, the bottom surface 312 and the top surface 314 are not angled. A wall 317 of the shoulder 217 is seen along the outside of the shoulder 217. The wall 317 in the current embodiment defines a draft portion 316 having a draft angle such that the thickness of the shoulder 217 at a beginning of the draft 318 is thicker than the thickness at an end of the draft 319. The angle of the draft portion 316 is consistent between the beginning of the draft 318 and the end of the draft 319 so that the region defining the draft angle is a linear taper in the current embodiment, although other shapes may be used in various embodiments. A radiused portion 321 extends beyond the draft portion 316 to provide an end 334 of the shoulder 217 beyond the fastener hole 132b. The wall 317 includes an outer surface 322.

[0030] As can be seen from the view of FIG. 3, the shoulder 217 includes a taper portion 326. The taper portion 326 terminates at the end 334 of the shoulder 217 and melds at the other end with a parallel portion 327 of the shoulder 217. As previously described, the bottom surface 312 is parallel to the top surface 314 in the parallel portion 327. A ledge surface 331a,b provides a quick transition to the taper portion 326, which includes a taper bottom surface 332 that is not parallel to the top surface 314. An inner surface 335b of the fastener hole 132b can also be seen in the current view.

[0031] The tongue 280 includes three portions in the current embodiment: a central portion 342, a first side portion 344, and a second side portion 346. The side portions 344,346 are oriented with respect to the central portion 342 such that an angle is formed between each. In the current embodiment, the angle is greater than ninety degrees. The tongue 280 includes an outer surface 352, an inner surface 354, and a mating surface 355. The mating surface 355 is angled at a tip angle 430, which is shown in FIG. 4. The mating surface 355 is located on a leading edge of the tongue 280.

[0032] Shown along the other end 203 is the other shoulder 213. The shoulder includes a bottom surface 362 and a top surface 364 that are substantially parallel. The shoulder 213 includes a draft portion 366 and a radiused portion 371. A taper portion 376 is included just like with shoulder 203. A parallel portion 377 is also included where the bottom surface 362 is parallel to the top surface 364 in the region. Ledge surfaces 381a,b (not shown) are also included just like ledge surfaces 331a,b, and a taper bottom surface 382 is also included.

[0033] A groove 380 is defined in the shoulder 213. The groove 380 is sized to accept the tongue 280. The groove 380 includes a central wall 392 and two side walls 394,396. The groove 380 is further defined by a mating surface 395. In assembly, the mating surface 395 contacts the mating surface 355' of another segment 110'. A groove shoulder surface 389 is included on the inside of the groove 380. A draft portion 388 can be seen proximate the end of the segment 110 nearest the groove 380. The draft portion 388 provides a relief from the inner surface 260 to the mating surface 395 to line up with the tongue 280', which is slightly set back from the inner surface 260'. The draft portion 388 helps prevent the coupling 100 from pinching the gasket 150 during installation, as pinching of the gasket 150 can lead to failure of the gasket 150 including slicing and rupture of the gasket 150. A draft portion shoulder surface 387a,b (387b not shown) provides the part of the step-down from a shoulder surface 296a,b (296b not shown) to the mating surface 395.

[0034] Each edge portion 225a,b of the segment 110 includes a contacting portion 292a,b and a support portion 294a,b. The contact surface 262a,b is included at the end of the contacting portion 292a,b. The shoulder surface 296a (296b not shown) can be seen at the inside end of the support portion 294a (inside end of the support portion 294b not shown). Three nodes 297a,298a (299a,b and 297b,298b not shown) protrude from the shoulder surface 296a,b between the support portion 294a,b and the

- contacting portion 292a,b. Each node 297a,b and 298a,b include a width that decreases from the support portion 294a,b to the contacting portion 292a,b. Although the nodes 297a,b, 298a,b, and 299a,b are pyramidal in the current embodiment, they may be various shapes in various embodiments.
- [0035]** The gasket 150 is designed to interact with the inner surface 260 of each segment 110 in the pipe coupling 100, as will be discussed with reference to FIG. 5.
- [0036]** As seen in the cross-sectional view of FIG. 4, the top surfaces 314,364 and the bottom surfaces 312,362 are aligned at angles 415,416,417,418 with respect to a horizontal axis 420 of the segment 110. A vertical axis 425 is shown for reference. The angles 415,416,417,418 allow for deflection of the segment 110 in use. In some embodiments, the angles 415,416,417,418 will be zero such that the top surfaces 314,364 are aligned with the horizontal axis 420 when no deflection is present. The tip angle 430 of the tongue 280 can be seen such that the mating surface 355 is aligned angularly with respect to the horizontal axis 420. The tip angle 430 is greater than the other angles 415,416,417,418 in the current embodiment, although other configurations may be found in various embodiments. When the segment 110 is deflected, the mating surface 355 contacts the mating surface 395 of another segment 110. In various embodiments, the tip angle 430 is approximately the same as the angles 415,417 of the top surface 314 and bottom surface 312, respectively.
- [0037]** Also seen in cross-sectional view, each fastener hole 132a,b is drafted such that each fastener hole 132a,b defines a cone-shaped void that is approximately ovular in cross-section, although various cross-sectional shapes may be found in various embodiments. As such, each fastener hole 132a,b includes a smaller aperture at the top surface 314,364 than where the fastener hole 132a,b emerges into the taper bottom surface 332,382 and the bottom surface 312,362. This configuration may be omitted in various embodiments.
- [0038]** As can be seen in FIG. 5, the gasket 150 is ring-shaped and includes an annular body 510 having a radially outer surface 515. The radially outer surface 515 interacts with the inner surface 260 of each segment 110 in the pipe coupling 100. The radially outer surface 515 of the annular body 510 includes a deformation groove 517. The annular body 510 includes side portions proximate axial ends of the annular body 510. Extending substantially radially inward from the side portions of the annular body 510 are a pair of sealing ribs 520a,b. Each sealing rib 520a,b extends substantially radially inwardly and increases in thickness from radially outside to radially inside. Each sealing rib 520a,b also has an axially outer surface 521a,b extending from the radially outer surface 515 to the start of an axially outer drafted edge 522a,b. Each axially outer surface 521a,b is angled with respect to a radial direction. The angle of each axially outer surface 521a,b is consistent around the entirety of the annular body 510, so that axially outer surfaces 521a,b are shaped as a truncated cone. In the current embodiment, each axially outer surface 521a,b is angled between nineteen and twenty-two degrees

with respect to a radius of the gasket 150, although other configurations may be present in various embodiments.

[0039] Each sealing rib 520a,b has a sealing ridge 525a,b extending axially inward from a radially inward end 551a,b of each sealing rib 520a,b. Each sealing ridge 525a,b extends substantially axially inward from the radially inward end 551a,b of each sealing rib 520a,b, such that the two sealing ridges 525a,b extend toward each other. The axially outer drafted edges 522a,b extend from the radially inward end 551a,b to a contact portion 555a,b. Each axially outer drafted edge 522a,b may be rounded, slanted, or various shapes in cross-section in various embodiments. Such cross-sectional shapes translate to conical and paraboloid shapes in various embodiments. Such shapes are truncated, as a full cone or paraboloid would not allow insertion of pipe elements in the gasket 150. In the embodiment shown in FIG. 5, the axially outer drafted edges 522a,b are slanted at an angle approximately between 27° and 28° from a radial direction, although various other angles may be present in various embodiments. Contact portions 555a,b extend along the sealing ridges 525a,b from the axially outer drafted edges 522a,b to an axially inner drafted edge 527a,b. Each contact portion 555a,b includes a sealing surface 526a,b facing radially inward and coplanar or collinear with each other in the cross-sectional view. The coplanar/collinear arrangement in cross-sectional view denotes a coannular surface profile of the sealing surfaces 526a,b in the current embodiment, although the surfaces may be of different diameters in various embodiments. The sealing surfaces 526a,b are intended to contact pipe elements placed inside of the gasket 150 to provide a fluid seal for the pipe elements. The sealing surfaces 526a,b face radially inwardly and extend substantially axially at rest. In other words, by “face radially inwardly,” when the sealing surfaces 526a,b are not in contact with pipe elements, the sealing surfaces 526a,b approximate a cylinder that is about coaxial with the pipe elements intended to be used with the coupling 100. Thus, the sealing surfaces 526a,b appear as lines that are parallel with the axis of pipe elements 710 in cross-sectional view, as seen in FIGs. 8A–8E. Any angle with respect to the pipe elements 710 is minimal.

[0040] The orientation of the sealing surfaces 526a,b is intended to ease the insertion of pipe elements into contact with the sealing surfaces 526a,b of gasket 150. Extending from each sealing surface 526a,b is the axially inner drafted edge 527a,b. The axially inner drafted edges 527a,b may be rounded, slanted, or various shapes in cross-section in various embodiments. Such cross-sectional shapes translate to paraboloid and conical shapes in various embodiments. Such shapes are truncated, as a full cone or paraboloid would not allow insertion of pipe elements in the gasket 150. The axially inner drafted edges 527a,b define the termination of the sealing ridge 525a,b along the axially inward direction.

[0041] A center rib 530 extends radially inward from the annular body 510. The center rib 530 includes a central groove 531 and two sealing members 557a,b which each include a sealing surface 532a,b. Each sealing member 557a,b in the current embodiment is a rounded protrusion from the central groove 531. In various embodiments, various shapes and configurations of sealing members 557a,b may be used, including flattened shapes, combinations of protrusions, and unconnected surfaces, among others. The sealing surface 532a,b is included on the sealing member 557a,b, respectively. The central groove 531 is positioned between the sealing surfaces 532a,b such that the sealing surfaces 532a,b of the sealing members 557a,b are capable of contacting the pipe elements and providing additional sealing interaction therewith.

[0042] Each sealing rib 520a,b has an innermost radial extent as measured from the annular body 510. In addition, each sealing rib 520a,b has an edge radial extent as measured from the annular body 510 to an axially innermost end of each of the axially inner drafted edges 527a,b. The center rib 530 has an innermost radial extent as measured from the annular body 510. The innermost radial extent of the center rib 530 is closer to the annular body 510 than the innermost radial extent of each of the pair of sealing ribs 520a,b. Additionally, in the current embodiment, the innermost radial extent of the center rib 530 is closer to the annular body 510 than the edge radial extent of each of the pair of sealing ribs 520a,b. The innermost radial extent of the center rib 530 may be as far from the annular body as, or farther from the annular body 510 than, the edge radial extent of each of the pair of sealing ribs 520a,b in various embodiments. The innermost radial extent of the center rib 530 may also be equally as far from the annular body 510 as the innermost radial extent of each of the pair of sealing ribs 520a,b in various embodiments.

[0043] The gasket 150 may be made of rubber, plastic, cork, wood, metal, ceramic, polymer, elastomer, rosin, foam, any combination of the foregoing materials, or any material suitable for sealing two pipe elements joined in end-to-end relationship. "Pipe elements" may mean pipes, valves, meters, or any other piping joint suitable to be sealed.

[0044] The annular body 510, the sealing ribs 520a,b, and the center rib 530 define gasket channels 540a,b as seen in FIG. 5. The gasket channels 540a,b are pockets into which fluid media may flow when the gasket 150 is in use. The gasket channels 540a,b are tubular channels in the current embodiment but may be various shapes in various embodiments. When placed in sealing contact with an exterior surface of a pipe element, the gasket channels 540a,b allow some fluid pressure to aid in sealing the sealing ridges 525a,b against pipe elements, although such use is not necessary for successful sealing of the gasket 150. The center rib 530 decreases in thickness from its radial outermost to its termination radially inward.

[0045] In addition, when the gasket 150 is in use, the sealing members 557a,b and the groove 531 act to prevent substantial fluid media flow into the gasket channels 540a,b. When placed in sealing contact with exterior surfaces of pipe elements, the sealing surfaces 532a,b of the sealing members 557a,b prevent substantial fluid media flow into gasket channels 540a,b, retaining fluid media flow in the groove 531. The gasket, in alternative embodiments, may include a plurality of center ribs, each with at least one sealing member and at least one sealing surface, which perform the same function as described above to prevent substantial media flow into the gasket channels.

[0046] One problem that the center rib 530 can alleviate is the buildup of fluids in the gasket channels 540a,b. For example, in applications where fluid media is water in cold temperature environments, preventing water buildup in the gasket channels 540a,b can lead to damage to the gasket 150 if the water freezes and, thereby, expands.

[0047] FIG. 6 shows the coupling 100 in an assembled but untightened position. It can be seen in this view that each top surface 314,314' is parallel to each bottom surface 312,312', respectively. Likewise, each top surface 364,364' is parallel to each bottom surface 362,362', respectively. However, the fastener pads 130a,b,a',b' are not aligned. In other words, the surfaces of adjacent fastener pads 130a,b,a',b' are not parallel. As can be seen, top surface 314 is not parallel to top surface 364 because angles 415 and 416 do not align. This angular misalignment allows each segment 110,110' to deflect under tightening pressure of the bolts 120a,b and nuts 125a,b to provide so that the top surfaces 314,314' and 364,364' are substantially parallel when the segments 110,110' are deformed. In various embodiments, the top surfaces 314,314' and 364,364' may be parallel before deforming the segments 110,110'. In such embodiments, the top surfaces 314,314' and 364,364' may be non-parallel after deflection.

[0048] As can be seen in FIG. 6, the groove shoulder surface 389 of segment 110' is angled so that it aligns with an outer surface 352' of tongue 280' of segment 110' upon deformation of the segments 110,110' as will be shown below in FIG. 7. Upon deformation of the segments 110,110' (as described below), the grooved shoulder surface 389 of segment 110 becomes parallel and flush with outer surface 352' of tongue 280' of segment 110', and grooved shoulder surface 389' of groove 380' of segment 110' becomes parallel and flush with outer surface 352 of segment 110.

[0049] As can be seen in FIG. 6, the annular nature of the gasket 150 defines a coupling void 410 within the gasket 150 that is adapted for certain diameters of pipe elements. In practice, when pipe elements are introduced within the gasket 150, they are placed inside the coupling void 410. Also seen in FIG. 6, a central axis of each of the bolts 120a,b is parallel to the vertical axis 425 such that heads 612a,b of the bolts 120a,b sit at an angle with the top surfaces 314, 316. In alternative embodiments, the bolts 120a,b may be angled with respect to the vertical axis 425 such that heads of the bolts

120a,b sit flush against the top surfaces 314,364. In the current embodiment, the gasket 150 sits within the segments 110,110'. Each of the sealing surfaces 526a,b of the gasket 150 has the same cylindrical profile and the same radius as the contact surfaces 262a,b,a',b'. In alternative embodiments, the sealing surfaces 526a,b of the gasket 150 may have a smaller or a larger radius than the contact surfaces 262a,b,a',b'. In many embodiments, sealing surfaces 526a,b are in contact with the outer surfaces of the pipe elements before the tightening elements (bolts 120a,b and nuts 125a,b) are engaged. In those embodiments, further compression of the gasket 150 will not necessarily produce a more effective seal. However, in other embodiments, it may be necessary for the segments 110,110' to compress the gasket 150 to effectuate a useful seal against the outer surface of the pipe elements. In many embodiments, sealing surfaces 532a,b are positioned in contact with or slightly above contact with the pipe elements. In those embodiments, deformation of the gasket 150 is necessary to seal the sealing surfaces 532a,b against the pipe elements. In some embodiments, however, sealing surfaces 532a,b are in sufficient engagement with the pipe elements prior to engagement of the tightening elements (bolts 120a,b and nuts 125a,b) so that further tightening does not necessarily effectuate a better seal.

[0050] Upon compression of the gasket 150 by the segments 110,110', the gasket 150 will most naturally deform from about circular in shape to an oblong shape. In most applications, compression by the segments 110,110' on the gasket 150 will compress the gasket along the vertical axis 425, but the gasket 150 will tend to extend along the horizontal axis 420. This occurs particularly because the segments 110,110' first contact the pipe elements—and, thus, first compress the gasket 150—at a point central to the segments 110,110'. As shown in FIGs. 4 and 6, the tongues 280,280' of the segments 110,110' extend beyond the horizontal axis 420, thereby preventing the annular deformation of the gasket 150. Deformation of the gasket 150 is properly directed to the deformation groove 517 by the tongue 280 and groove 380 configuration of the coupling 100. The restraint against oblong deformation provided by the tongues 280,280' promotes more uniform compression of the gasket 150 against the pipe elements, thereby providing a more reliable seal.

[0051] Tightening of the tightening elements (bolts 120a,b and nuts 125a,b) seats the gasket 150 against the pipe elements. When the segments 110,110' are properly deformed and the gasket 150 is properly seated, the coupling 100 restrains the pipe elements from pullout because the contacting portion 292a,b,a',b' (not shown in FIG. 6) of each segment 110,110' is seated inside at least one groove of at least one pipe element. The gasket 150 is compressed in sealed engagement with the pipe elements. In some embodiments, the sealing members 557a,b may be replaced by a single sealing member that extends between the two pipes. Such deformation allows heads 612a,b of the bolts 120a,b to seat

flush against the top surfaces 314,364 of segment 110 while nuts 125a,b seat flush against the top surfaces 314',364' of segment 110'.

[0052] When properly seated, media (such as water, gas, or other fluid) may be allowed to flow through the pipe elements. The gasket 150 seals such media in at least one of two ways. If the gasket 150 is compressed so that sealing surfaces 532a,b of the sealing members 557a,b are properly seated against the outside of the pipe elements, such sealing interaction may be sufficient to contain the media inside the pipe elements without breaching the joint. In some applications, such sealing engagement may be impossible to attain, or the pressure of media within the pipe elements may be too great for such a sealing engagement to effectuate a proper seal. In such applications, media may travel past the sealing members 557a,b and into the gasket channels 540a,b.

[0053] If media passes into the gasket channels 540a,b, there are two safeholds against leakage. First, in many applications, sealing surfaces 526a,b are in sealing engagement with the pipe elements prior to compression of the gasket 150 by the segments 110,110', and further compression of the gasket 150 enhances such sealing engagement. In other applications, sealing engagement of the gasket 150 with the pipe elements is achieved by compression of the gasket 150 by the segments 110,110'. Second, if media passes into the gasket channels 540a,b, it is assumed that such media is of a higher pressure than atmospheric. As such, the higher pressure in the gasket channels 540a,b further forces the sealing ridges 525a,b against the pipe elements. The higher pressure results in an even more effective seal by using the pressure of the media inside the pipe elements to effectuate a more complete seal. If liquid media is found in the pipe, such liquid may provide additional air-tight seal to further aid the engagement of the gasket 150 with the pipe elements. In some embodiments, gas-proofing grease may be applied to the contact surfaces 526a,b and 532a,b to aid in sealing. In many embodiments, grease is unnecessary.

[0054] In the current embodiment, the coupling 100 is assembled in the untightened position of FIG. 6 before use. In other embodiments, the coupling 100 may be assembled in various pieces as part of the method of use.

[0055] The coupling 100 in FIG. 7 is shown tightend and deformed around a pair of pipe elements 710b,a (710a not shown in FIG. 7). The segments 110,110' in the current view are fully deformed in the current embodiment, and contact surfaces 262b,a' touch a groove surface 714b,a (714a not shown in FIG. 7), which is the outer surface of the pipe element 710 within the groove 720b,a (not shown in FIG. 7). Contact surface 262a of segment 110 and contact surface 262b' of segment 110' are not shown in FIG. 7 because they are obstructed by the view. As described above, in some embodiments, the shoulder surfaces 296a,b,a',b' may contact an outermost surface of each pipe element 710a,b outside of the groove 720b,a (not shown in FIG. 7), and the contact surfaces 262a,b,a',b' may never

contact the groove surface 714a,b of each pipe element 710a,b within each groove 720a,b. In other embodiments, the contact surfaces 262a,b,a',b' contact the groove surfaces 714a,b.

[0056] When the segments 110,110' travel toward each other and deform under the tightening of the tightening elements (nuts 120a,b and bolts 125a,b), the gasket 150 is deformed in accord therewith. In some embodiments, a rigid or semi-rigid gasket 150 may be included. The process for accommodating such a material may be altered from that described herein. The gasket 150 includes the deformation groove 517 to allow a place for material to go upon deformation of the gasket 150.

[0057] Installation of the coupling 100 on the pair of pipe elements 710a,b is illustrated in FIGs. 8A–8E. For the current embodiment, the coupling 100 is introduced to a pair of pipe elements 710a,b in the preassembled but untightened position of FIG. 6. Each pipe element 710a,b may include at least one groove 720a,b for alignment with contact surfaces 262a,b,a',b'. In the currently described method, the coupling 100 is aligned with an end 725a of the first pipe element 710a as shown in FIG. 8A. The coupling 100 is installed by placing the end 725a of the first pipe element 710a in the coupling void 410 and forcing the coupling 100 onto the first pipe element 710a as shown in FIG. 8B. As seen in FIG. 8B, sealing surfaces 526a,b and sealing surfaces 532a,b are a small distance away from an outer surface 715a of the first pipe element 710a, although the sealing surfaces 526a,b and 532a,b may contact the outer surface 715a in some embodiments. In the currently-described method, the entire coupling 100 is forced beyond the groove 720a of the first pipe element 710a so that the contact surfaces 262b,b' have passed the groove 720a. In some embodiments, it may not be necessary to force the entire coupling 100 beyond the groove 720a. As seen in FIG. 8C, the second pipe element 710b having an end 725b is introduced in end-facing relationship to the end 725a of the first pipe element 710a. In the current embodiment, the pipe elements 710a,b are approximately the same diameter, although non-uniform diameter pipe elements may be joined in various embodiments. In the current embodiment, each pipe element 710a,b has ends 725a,b that are flared slightly. Grooves 720a,b can be formed in one of two ways: rolled or machined. If the grooves 720a,b are machined, the pipe elements 710a,b are unlikely to have flares on the ends 725a,b as shown. However, if the grooves 720a,b are rolled, the pipe elements 710a,b are more likely to have flares on the ends 725a,b. As such, the coupling 100 of the current embodiment is designed to accommodate the potential flaring of ends 725a,b. The coupling 100 is sized to fit over the largest possible flare of the ends 725a,b in the current embodiment based on standard tolerancing for creating the grooves 720a,b.

[0058] When the second pipe element 710b is about aligned with the first pipe element 710a, the coupling 100 is moved so that the gasket 150 is aligned on outer surfaces 715a,b over the ends 725a,b of the pipe elements 710a,b and with the contact surfaces 262a,b,a',b' aligned with the grooves 720a,b, as shown in FIG. 8D. As seen in FIG. 8E, when the segments 110,110' are clamped down, the

gasket 150 deforms into sealing engagement the outer surfaces 715a,b of the pipe elements 710a,b and the contact surfaces 262a,b,a',b' sit within the grooves 720a,b and touch groove surfaces 714a,b. In various embodiments, the contact surfaces 262a,b,a'b' may not touch groove surfaces 714a,b upon clamping down the segments 110,110'.

[0059] Several features of the gasket 150 ease installation as described. Friction can cause installation of rubber gaskets to bind against outer surfaces 715a,b of pipe elements 710a,b. With reference to FIG. 3, FIG. 5, FIG. 6, and the method previously described with FIGs. 8A–8E, axially outer drafted edges 522a,b and axially inner drafted edges 527a,b are both drafted to ease the pipe elements 710 into the coupling void 410. Axially outer drafted edges 522a,b and axially inner drafted edges 527a,b also help to prevent rollover of the sealing ridges 525a,b of the gasket 150 during sliding on and off, as the drafted profiles are less likely to bind against the outer surfaces 715a,b of the pipe elements 710a,b. Additionally, contact portions 555a,b are substantially parallel to the outer surface 715a,b of the pipe elements 710a,b even when the gasket 150 is not seated on a pipe elements 710a,b. Additionally, the configuration of the center rib 530 with respect to the sealing ribs 527a,b, as discussed above with reference to FIG. 5, prevents the center rib 530 from obstructing the installation of the coupling 100 by providing limiting contact between the center rib 530 and the outer surface 715a,b of pipe elements 710a,b before deformation of the gasket 150. When the segments 110,110' are clamped down, the gasket 150 deforms, and the center rib 530 contacts the outer surface 715a,b of pipe elements 710a,b. This configuration allows the gasket 150 to slide onto the pipe elements 710a,b without biasing the sliding in one direction and prevents binding of the sealing ridges 525a,b during installation. These features prevent the gasket 150 from rolling over when the coupling 100 is installed on the pipe elements 710a,b and allows the gasket 150 to be properly placed over the joint between the pipe elements 710a,b for proper sealing, among other advantages. When the gasket 150 is properly aligned over the joint, each of the sealing members 557a,b may contact the outer surface 715a,b of one pipe element 710a,b or may be aligned above the surface 710a,b of the pipe elements 715a,b. However, the alignment of the sealing members 557a,b is not critical to effectuate a seal of the joint.

[0060] When the coupling 100 is aligned on the joint of the pipe elements 710a,b, the tightening elements are used to draw the segments 110,110' together. In the current embodiment, this takes the form of nuts 125a,b tightening down on bolts 120a,b to compress the fastener pads 130a,b,a',b' toward each other. In some embodiments, the coupling 100 is rigid and includes no deflection of the segments 110,110'. In the current embodiment, the engagement of the tightening elements (bolts 120a,b and nuts 125a,b) first cause the segments 110,110' to travel toward each other. When the segments 110,110' contact the pipe elements 710a,b, the segments 110,110' deform (deflection) until

each segment 110,110' is in the desired engagement with the pipe elements 710a,b. The deformation of the segments 110,110' can be seen by comparing FIGs. 6 and 7. The contact surfaces 262a,b,a',b' contact groove surfaces 714a,b of the grooves 720a,b in the pipe elements, at which time the segments 110,110' begin deflection. In some embodiments, shoulder surfaces 296a,b,a',b' (refer to FIG. 4 for the location of shoulder surfaces 296a,b,a',b') contact the outer surface of the pipe elements such that the contact surfaces 262a,b,a',b' never contact the groove surfaces 714a,b.

[0061] As can be seen in FIG. 7, the segments 110,110' may deflect so that bottom surfaces 362,362' are in contact with bottom surfaces 312',312, respectively, in some embodiments. This configuration need not be present in all embodiments. In some embodiments, the mating surfaces 355,355' will contact mating surfaces 395',395, respectively, before the bottom surfaces 362,362' contact bottom surfaces 312',312, respectively. In some embodiments, bottom surfaces 362,362' will contact bottom surfaces 312',312 before mating surfaces 355,355' contact mating surfaces 395',395, respectively. Because of the deflection and deformation of the segments 110,110', the angles 415,416,417,418, as pointed out in FIG. 4 (angles 415',416',417',418' not shown), are reduced as the top surfaces 314,314' and 364,364' and the bottom surfaces 312,312' and 362,362' approach a position parallel with the horizontal axis 420. As shown, mating surfaces 355,355' are in contact with mating surfaces 395',395, respectively, as well.

[0062] Seen in the cross-sectional view of FIG. 9, each bolt 120a,b (b not shown in FIG. 9) includes a head 612a,b (b not shown in FIG. 9), a threaded portion 810a,b (b not shown in FIG. 9), a shank portion 815a,b (b not shown in FIG. 9), and a collar portion 820a,b (b not shown in FIG. 9). Combined together, each threaded portion 810a,b, shank portion 815a,b, and collar portion 820a,b is termed the shaft portion. Each shaft portion may omit any combination of the threaded portion 810, shank portion 815, and collar portion 820 in various embodiments. The nuts 125a,b (b not shown in FIG. 9) engage the bolts 120a,b (b not shown in FIG. 9) along part of the threaded portion 810a,b. Tightening of the nuts 125a,b compresses the fastener pads 130a,b,a',b' and deforms the segments 110,110' to conform to the shape of the pipe elements, as previously described.

[0063] As previously described, when the coupling 100 is installed onto pipe elements, the assembled and untightened coupling 100 is installed over the edge of the first pipe element 710a until it passes completely over any groove 720a in the first pipe element 710a after which the second pipe element 710b is placed end-facing to the first pipe element 710a. The coupling 100 is then slid into position straddling the first and second pipe elements 710a,b. Although (as previously described) it is common for gaskets to bind during such installation, it is also possible for friction to cause rocking of the segments 110,110' not only against any gasket but also against the exterior of the pipe elements 710a,b. If a leading edge of one segment 110,110' catches against the exterior of the pipe element

710a,b, the segments 110,110' have a tendency to rock with respect to each other. Rocking of segments 110,110' can cause additional binding of the gasket 150, making installation of the coupling 100 difficult and potentially damaging to components of the coupling 100, including the gasket 150.

[0064] The shape of the fastener hole 132a (see FIG. 2) includes an axial length 233 (axial length 237 of fastener hole 132b not shown) that tends to prevent such rocking of the segments 110. For the fasteners of the current embodiment, each of the heads 612a,b, threaded portions 810a,b, and shank portions 815a,b are symmetrical about the center of the bolt 120a,b, respectively. The shank portions 815a,b are cylindrical, the threaded portions 810a,b are cylindrical except that each has threading along its outermost edge, and the heads 612a,b are cross-sectionally circular at cross-sections taken orthogonal to the center axis. However, the collar portions 820a,b are not cylindrical but instead include a profile approximating that of the fastener holes 132a,b as measured at the top surfaces 364,314. Each collar portion 820a,b includes an axial length 830a,b that is about the same as the diameter of the shank portions 815a,b. The collar portions 820a,b also include a transverse length (not shown) that is proportionally larger than the axial length 830a,b. The axial length 830a,b of each collar portion 820a,b may be smaller than the axial length 233,237 of each fastener hole 132a,b, the transverse length of each collar portion 820a,b may be smaller than the transverse length 243,247 of each fastener hole 132a,b, and the axial length 233,237 of each fastener hole 132a,b is smaller than the transverse length 830a,b of each collar portion 820a,b.

[0065] The arrangement of each collar portion 820a,b engages the fastener hole 132a,b in assembly and retains the bolt 120 in a fixed arrangement with respect to the segment 110 in each fastener hole 132a,b. This allows a user to tighten the nuts 125a,b without need to restrain the bolts 120a,b, as the collar portions 820a,b retain the bolts 120a,b through interaction with the fastener holes 132a,b. This result occurs because the axial length 233,237 of each fastener hole 132a,b is smaller than the transverse length 830a,b of each collar portion 820a,b. Such an arrangement would result even if the orientation of the fastener holes 132a,b were at a different angle.

[0066] However, the arrangement as displayed also prevents the rocking of the segments 110,110' by keeping the shank portions 815a,b, the collar portions 820a,b, and the threaded portions 810a,b in close proximity to the inner surfaces 335a,b,a',b' of the fastener holes 132a,b,a',b'. Should one of the segments 110,110' begin a rocking motion, at least one of the inner surfaces 335a,b,a',b' will contact at least one of the bolts 120a,b along at least one of the collar portions 820a,b, the shank portions 815a,b, and the threaded portions 810a,b thereby providing a mechanical stop to prevent further rotation of the segments 110,110' with respect to the bolts 120a,b and, thereby, with respect to the other segment 110',110.

[0067] Although all sides of the fastener holes 132a,b,a',b' are shown as drafted in the current embodiment, some sides may be drafted or may be parallel in various embodiments. For example, in the current embodiment, fastener holes 132a,b,a',b' are drafted because the segments 110,110' are cast. However, if fastener holes 132a,b,a',b' were machined, it would not be necessary to draft the fastener holes 132a,b,a',b'.

[0068] As seen in FIG. 10, each pair of contact surfaces 262a,b and 262a',b' (262b and 262b' shown in FIGs. 10 and 11) defines a predeformation radius 1001,1001'. Likewise, each pipe element 710a,b defines a radius 1002a,b. In the current embodiment, when the coupling 100 is in the untightened position, the predeformation radii 1001,1001' of each pair of contact surfaces 262a,b and 262a',b', respectively, is greater than the radii 1002a,b of the pipe elements 710a,b. Groove radii 1003a,b are also shown on the pipe elements 710a,b, respectively. Because the predeformation radii 1001,1001' are larger than the radii 1002a,b, the coupling 100 can be more easily maneuvered over each pipe element 710a,b as described more thoroughly with reference to FIGs. 8A–8E. Having larger predeformation radii 1001,1001' than radii 1002a,b allows the coupling 100 to be slid onto the pipe elements 710a,b as a preassembled unit. As described above, once the coupling 100 is aligned over the pipe elements 710a,b, no further assembly of the coupling 100 is required. Instead, the user need only tighten the nuts 125a,b on the bolts 120a,b to secure the coupling 100 in sealing engagement with the pipe elements 710a,b.

[0069] As seen in FIG. 11, once the nuts 125a,b are tightened onto the bolts 120a,b, each segment 110,110' of the coupling 100 deforms in conformity with the grooves 720a,b. Once deformed, a postdeformation radius 1101,1101' is defined by each pair of contact surfaces 262a,b and 262a',b' (262b and 262b' shown in FIGs. 10 and 11), respectively. In the current embodiment, each postdeformation radius 1101,1101' is equal to the groove radii 1003a,b because the contact surfaces 262a,b,a',b' contact the groove surfaces 714a,b. In embodiments where the contact surfaces 262a,b,a',b' do not contact the groove surfaces 714a,b, the postdeformation radii 1101,1101' may be larger than the groove radii 1003a,b. Although not required in all embodiments, the postdeformation radii 1101,1101' will likely be smaller than the radii 1002a,b even if the postdeformation radii 1101,1101' is larger than the groove radii 1003a,b.

[0070] This assembly configuration represents one of many possible assembly configurations. One skilled in the art will understand obvious variations of this assembly configuration are included within this disclosure, including variations of steps, combinations of steps, and dissections of steps, among others. Where materials are chosen for the elements of this assembly—particularly, rubber, metal, and cast iron—similar material choices may also be used and would be obvious to one in the art. As previously disclosed, the gasket 150 may be made of rubber, plastic, cork, wood, metal, ceramic,

polymer, elastomer, rosin, foam, any combination of the foregoing materials, or any material suitable for sealing two pipe elements joined in end-to-end relationship. The segments 110,110' may be made of cast iron, steel, aluminum, titanium, copper, brass, various plastics, polymers, resins, or any material of sufficient strength to withstand the tightening load of the fasteners.

[0071] It should be emphasized that the embodiments described herein are merely possible examples of implementations, merely set forth for a clear understanding of the principles of the present disclosure. Many variations and modifications may be made to the described embodiment(s) without departing substantially from the spirit and principles of the present disclosure. Further, the scope of the present disclosure is intended to cover any and all combinations and sub-combinations of all elements, features, and aspects discussed above. All such modifications and variations are intended to be included herein within the scope of the present disclosure, and all possible claims to individual aspects or combinations of elements or steps are intended to be supported by the present disclosure.

[0072] One should note that conditional language, such as, among others, “can,” “could,” “might,” or “may,” unless specifically stated otherwise, or otherwise understood within the context as used, is generally intended to convey that certain embodiments include, while other embodiments do not include, certain features, elements and/or steps. Thus, such conditional language is not generally intended to imply that features, elements and/or steps are in any way required for one or more particular embodiments or that one or more particular embodiments necessarily include logic for deciding, with or without user input or prompting, whether these features, elements and/or steps are included or are to be performed in any particular embodiment.

[0073] Various implementations described in the present disclosure may include additional systems, methods, features, and advantages, which may not necessarily be expressly disclosed herein but will be apparent to one of ordinary skill in the art upon examination of the following detailed description and accompanying drawings. It is intended that all such systems, methods, features, and advantages be included within the present disclosure and protected by the accompanying claims.

CLAIMS

1. An annular gasket comprising:

an annular body; and

a pair of sealing ribs extending substantially radially inward from the annular body, each sealing rib having a sealing ridge, the sealing ridge of each of the pair of sealing ribs having a sealing surface, the sealing surface of each sealing ridge being coannular in an undeformed state, the sealing surfaces defining a pair of radially innermost surfaces of the annular gasket.
2. The gasket of claim 1, wherein the pair of sealing ribs extend from side portions of the annular body.
3. The gasket of claim 1, wherein each of the pair of sealing ribs includes an outer surface and wherein an angle drawn between the outer surface of each of the pair of sealing ribs and a radial direction is between 19° and 22°.
4. The gasket of claim 1, wherein the sealing ridge of each of the pair of sealing ribs extends axially inwardly from a radially inward end of each of the pair of sealing ribs.
5. The gasket of claim 1, wherein the sealing ridge of each of the pair of sealing ribs includes an axially outer drafted edge.
6. The gasket of claim 5, wherein the axially outer drafted edge of each of the pair of sealing ribs extends from an axially exterior edge of each of the sealing surfaces of each of the pair of sealing ribs.
7. The gasket of claim 1, wherein the sealing ridge of each of the pair of sealing ribs includes an axially inner drafted edge.
8. The gasket of claim 7, wherein the axially inner drafted edge extends from an axially interior edge of each of the sealing surfaces of each of the pair of sealing ribs.

9. A method of installing a pipe coupling to connect a first pipe element to a second pipe element, the method comprising:

sliding the pipe coupling as a preassembled unit over an outermost surface of the first pipe element, the pipe coupling comprising a coupling segment and an annular gasket, the annular gasket comprising an annular body and a pair of sealing ribs extending substantially radially inward from the annular body, each sealing rib comprising a sealing ridge defining a sealing surface, the sealing surface of each sealing ridge being coannular in an undeformed state, the sealing surfaces defining a pair of radially innermost surfaces of the annular gasket;

introducing an end of the second pipe element to an end of the first pipe element to place the first pipe element and the second pipe element in end-facing relationship;

aligning the pipe coupling over the first pipe element and the second pipe element;

securing the coupling to the first pipe element and the second pipe element;

wherein the sealing surface of each sealing ridge defines a diameter greater than a diameter of the outermost surface of the first pipe element and a diameter of an outermost surface of the second pipe element; and

wherein sliding the pipe coupling as a preassembled unit over the outermost surface of the first pipe element comprises sliding the annular gasket over the outermost surface of the first pipe element without contacting the outermost surface of the first pipe element.

10. The method of claim 9, wherein each sealing rib increases in axial thickness from the annular body to a radially inward end of each sealing rib radially inside from the annular body, and wherein the sealing ridge of each sealing rib is connected to the radially inward end thereof.

11. The method of claim 9, wherein each sealing ridge decreases in axial thickness from a radially inward end of each sealing rib to the sealing surface of each sealing ridge.
12. The method of claim 9, wherein

the coupling segment is a first coupling segment;

the pipe coupling further comprises a second coupling segment secured end-to-end with the first coupling segment; and

securing the coupling comprises deforming and deflecting each coupling segment into engagement with each pipe element.
13. The method of claim 9, wherein sliding the pipe coupling comprises sliding the pipe coupling past the end of the first pipe element.
14. The method of claim 9, wherein the pair of sealing ribs extend from side portions of the annular body.
15. The method of claim 9, wherein the end of at least one of the first pipe element and the second pipe element is conically flared.
16. A method of installing a pipe coupling to connect a first pipe element to a second pipe element, the method comprising:

sliding the pipe coupling as a preassembled unit over an outermost surface of the first pipe element, the pipe coupling comprising a coupling segment and an annular gasket having an innermost diameter greater than a diameter of the outermost surface of the first pipe element and a diameter of an outermost surface of the second pipe element, the annular gasket comprising an annular body and a pair of sealing ribs extending substantially radially inward from the annular body, each sealing rib comprising a sealing ridge defining a sealing surface, the sealing surfaces defining a pair of radially innermost surfaces of the annular gasket, the annular gasket configured to slide over the diameters of the outermost surface of the first pipe element and the outermost surface of the second

pipe element without contacting the outermost surfaces of the first pipe element and the second pipe element in an undeformed state;

introducing an end of the second pipe element to an end of the first pipe element to place the first pipe element and the second pipe element in end-facing relationship;

aligning the pipe coupling over the first pipe element and the second pipe element; and securing the coupling to the first pipe element and the second pipe element;

wherein the sealing surface of each sealing ridge are coannular in the undeformed state; and

wherein each of the first pipe element and the second pipe element includes a flare.

17. The method of claim 16, wherein each sealing rib is increasing in axial thickness from the annular body to a radially inward end of each sealing rib radially inside from the annular body, and wherein the sealing ridge of each sealing rib is connected to the radially inward end thereof.
18. The method of claim 16, wherein each sealing ridge decreases in axial thickness from a radially inward end of each sealing rib to the sealing surface of each sealing ridge, and wherein each sealing ridge comprises an axially outer drafted edge angled at a non-zero angle with respect to a radial axis perpendicular to a main axis of revolution of the annular gasket.
19. The method of claim 18, wherein each axially outer drafted edge is conical.
20. The method of claim 16, wherein each sealing ridge includes an axially inner drafted edge.
21. The method of claim 16, wherein each sealing ridge extends axially inwardly from a radially inward end of each sealing rib.

22. The method of claim 21, wherein the sealing surface of each sealing ridge is cylindrical in the undeformed state.
23. The method of claim 16, wherein the annular gasket further comprises a center rib extending radially inward from the annular body, wherein the center rib decreases in axial thickness from radially outside to radially inside.
24. The method of claim 16, wherein an axially outer drafted edge of each sealing ridge extends from a radially inward end of each sealing rib to the sealing surface of each sealing ridge, and wherein each radially inward end is axially and radially outside compared to each of the sealing surfaces.

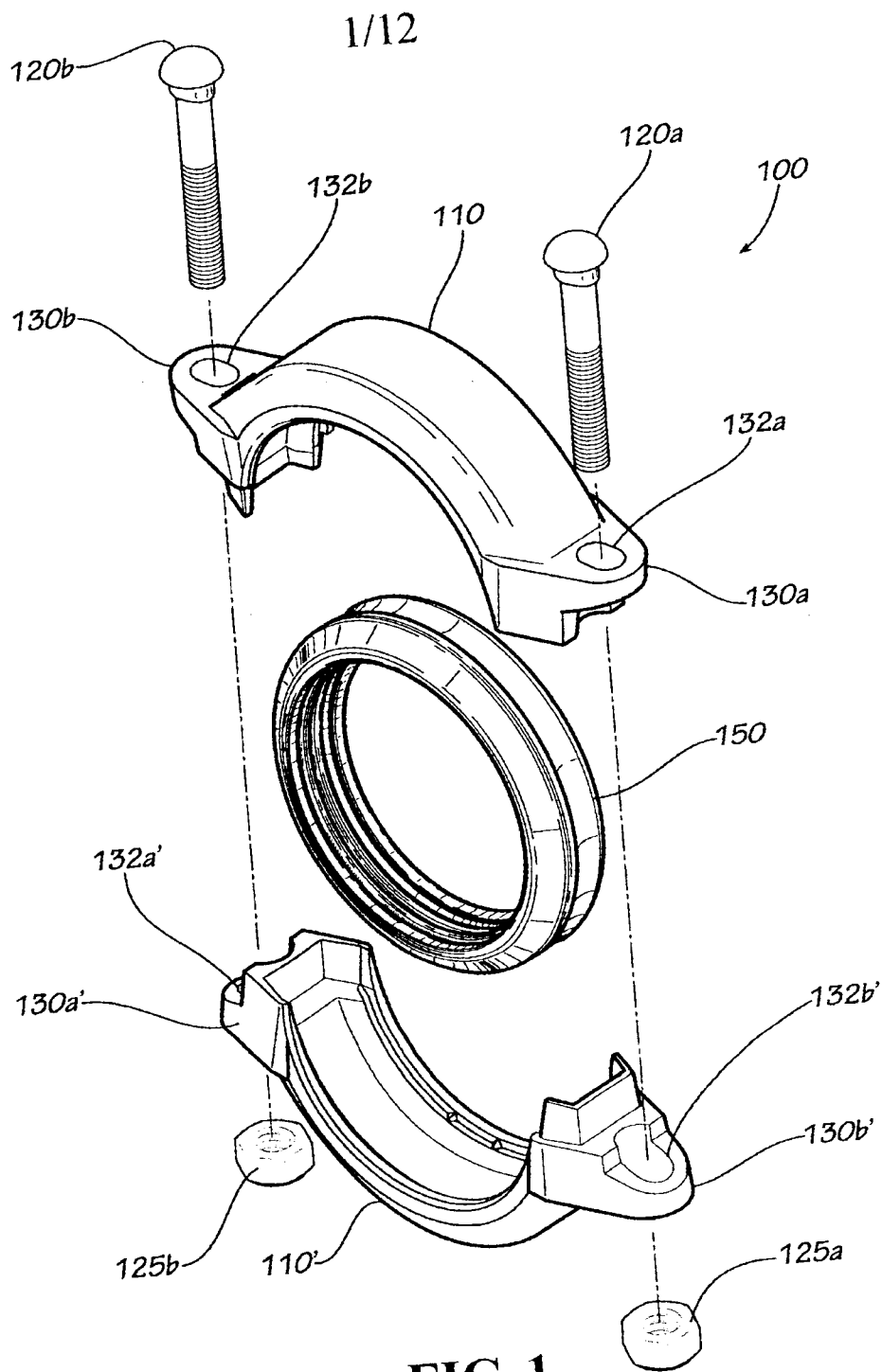
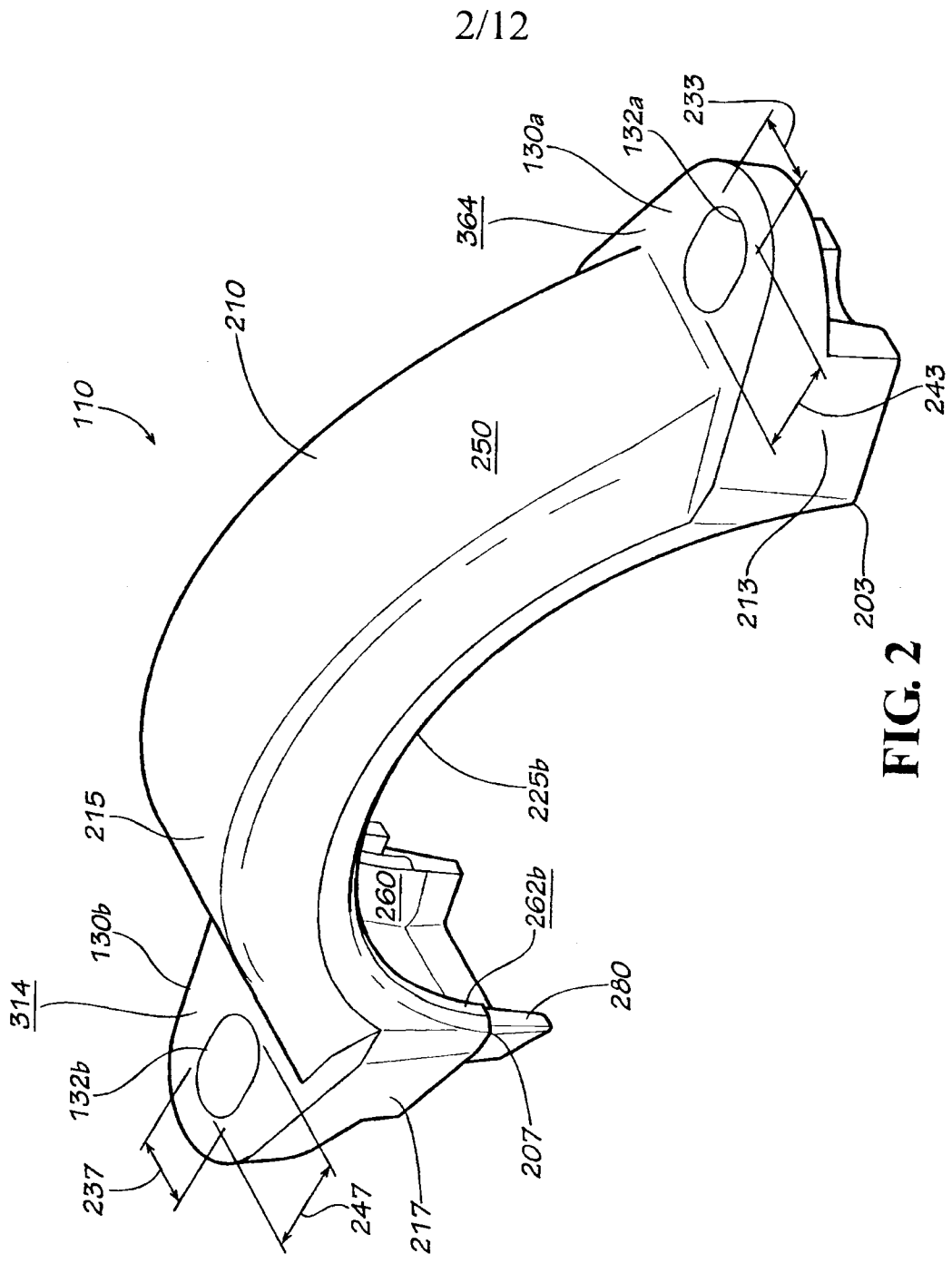

FIG. 1



2/12

FIG. 2

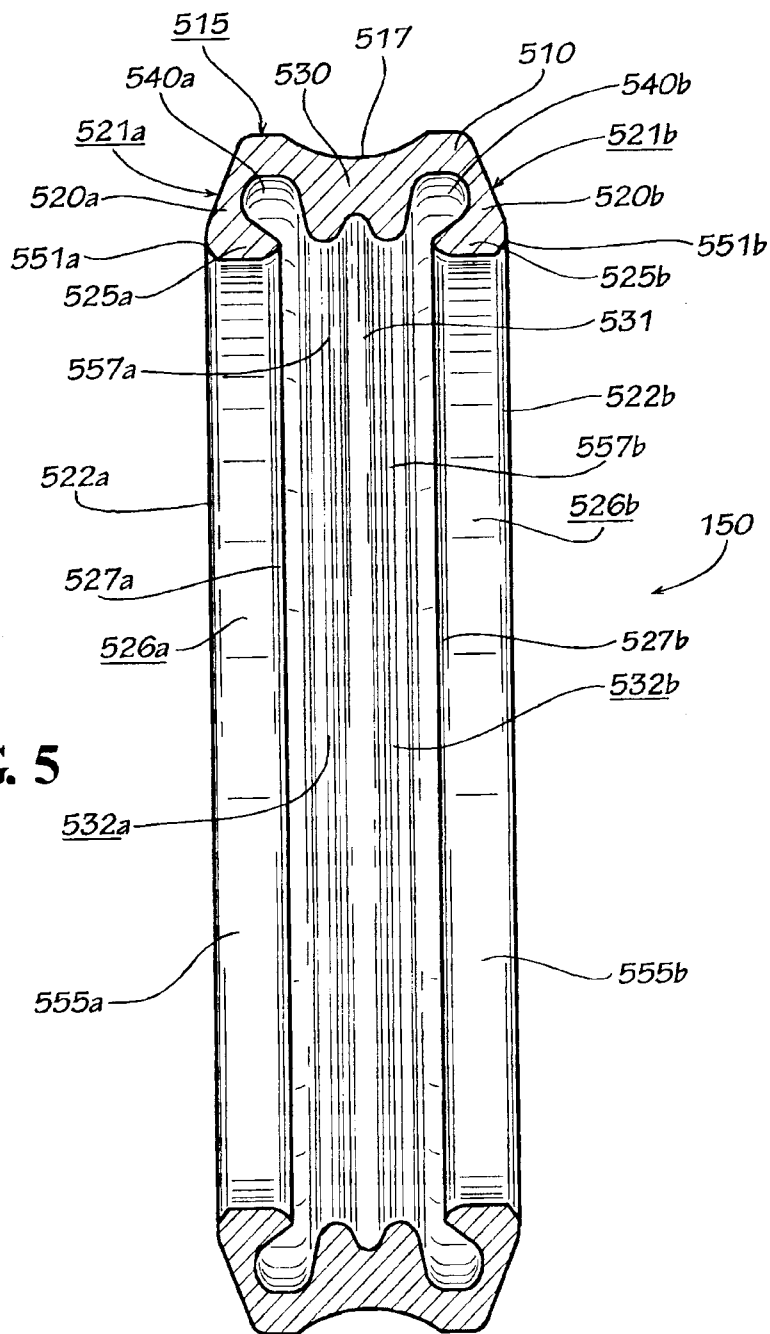

FIG. 5

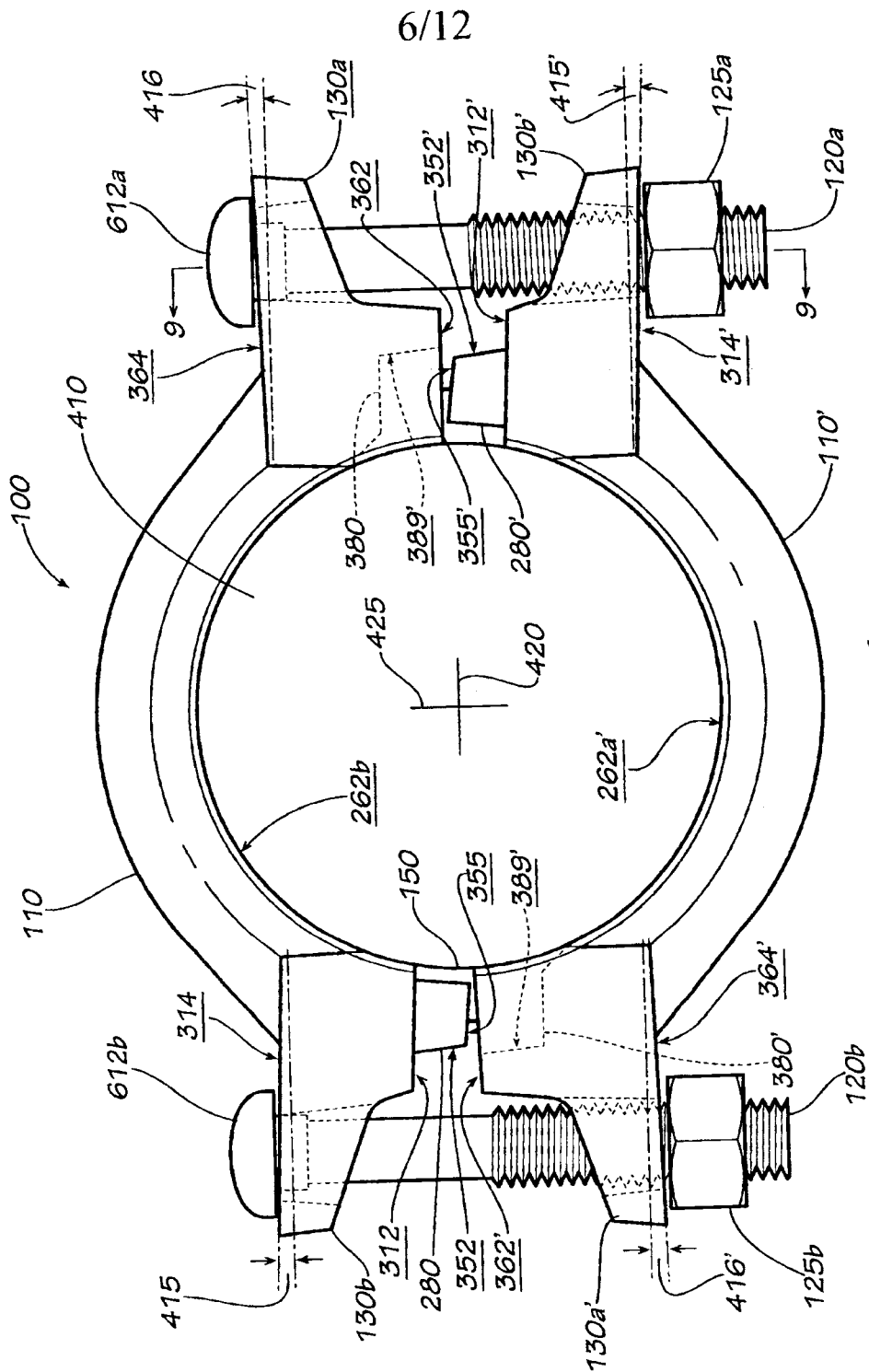

FIG. 6

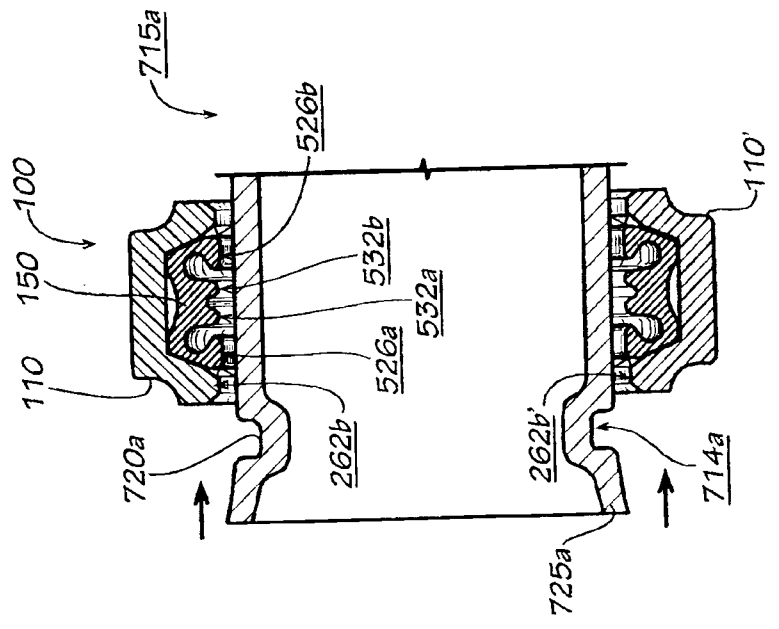

FIG. 8A

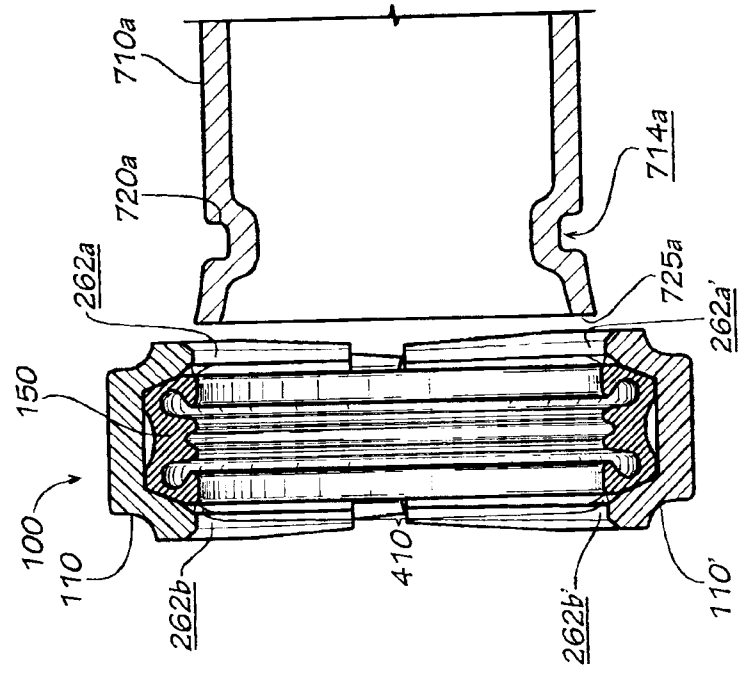

FIG. 8B

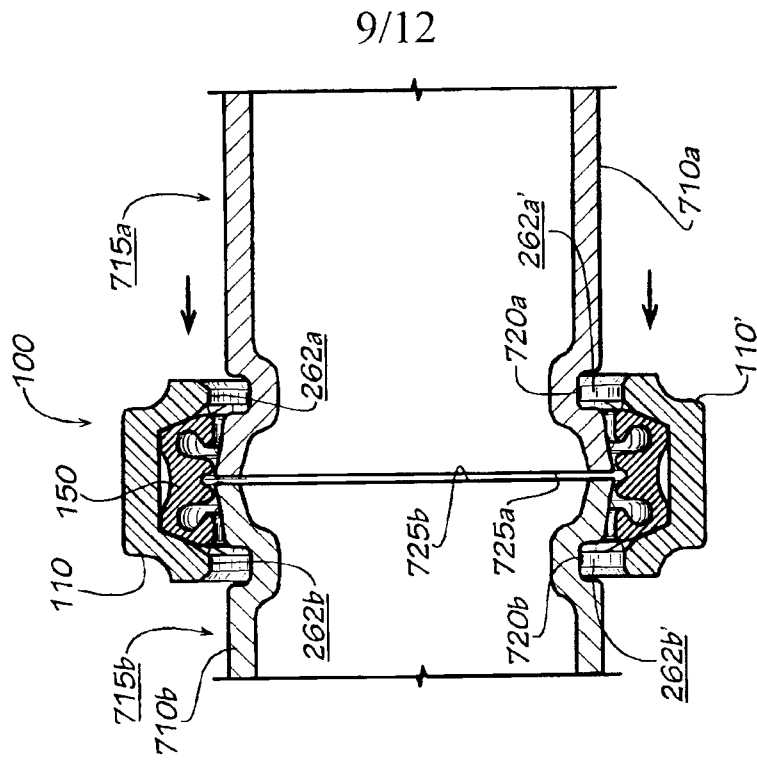

FIG. 8D

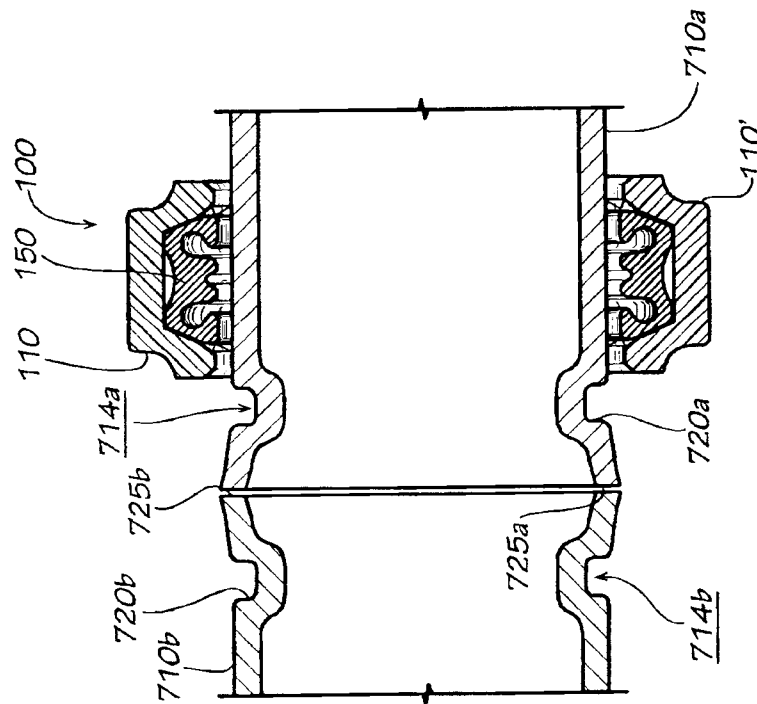

FIG. 8C

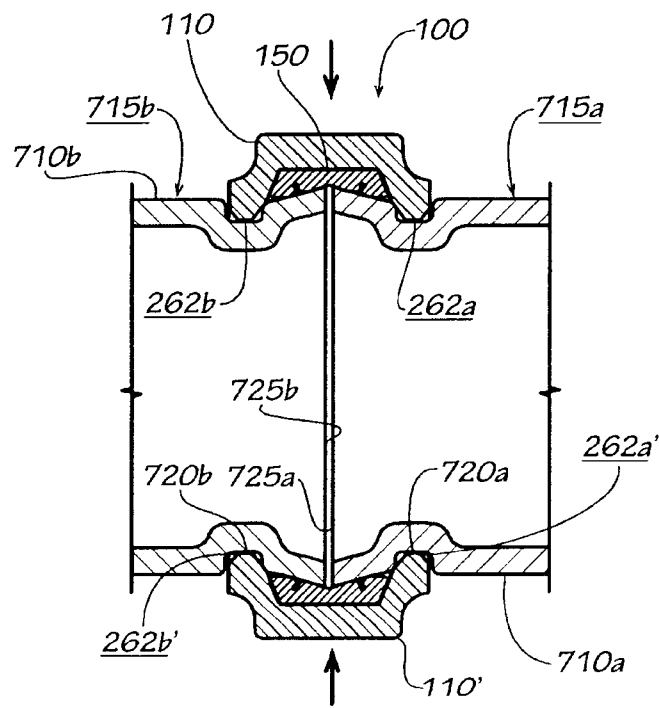

FIG. 8E

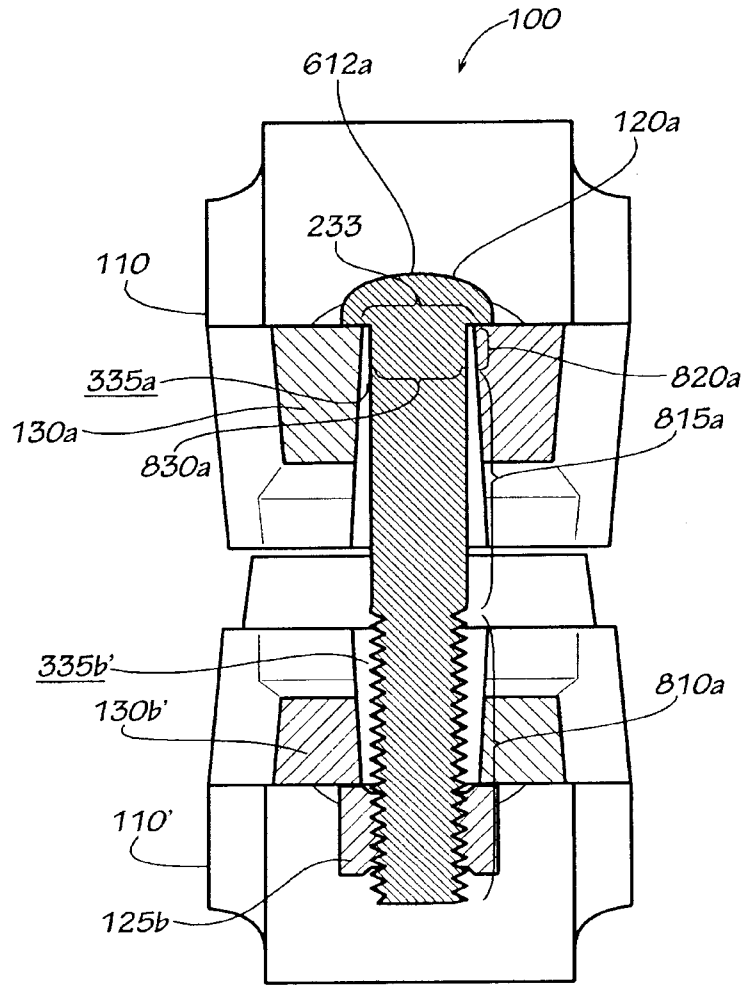

FIG. 9

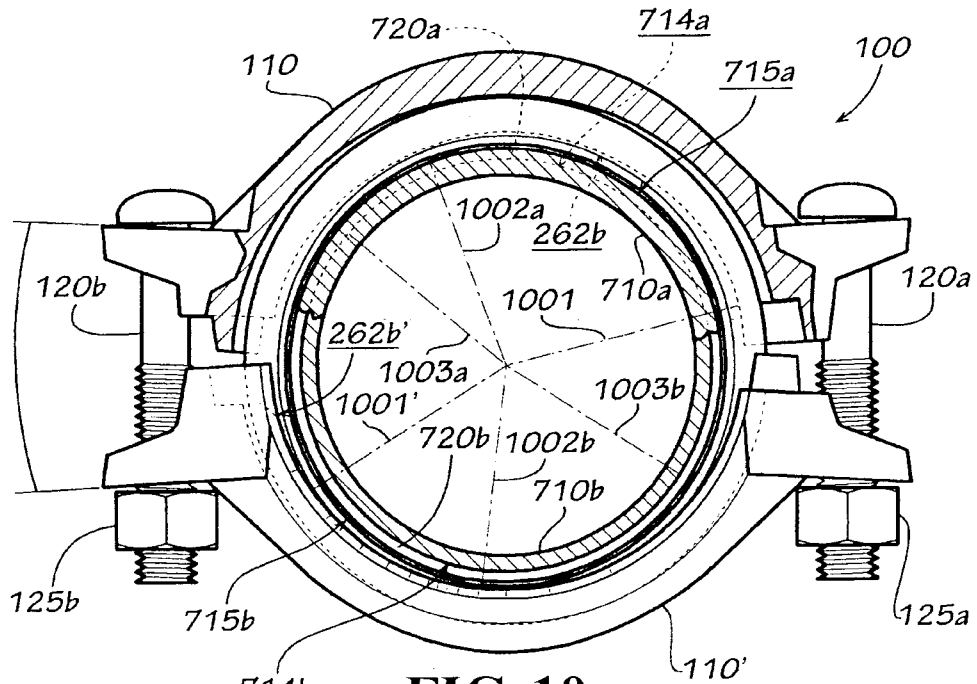

FIG. 10

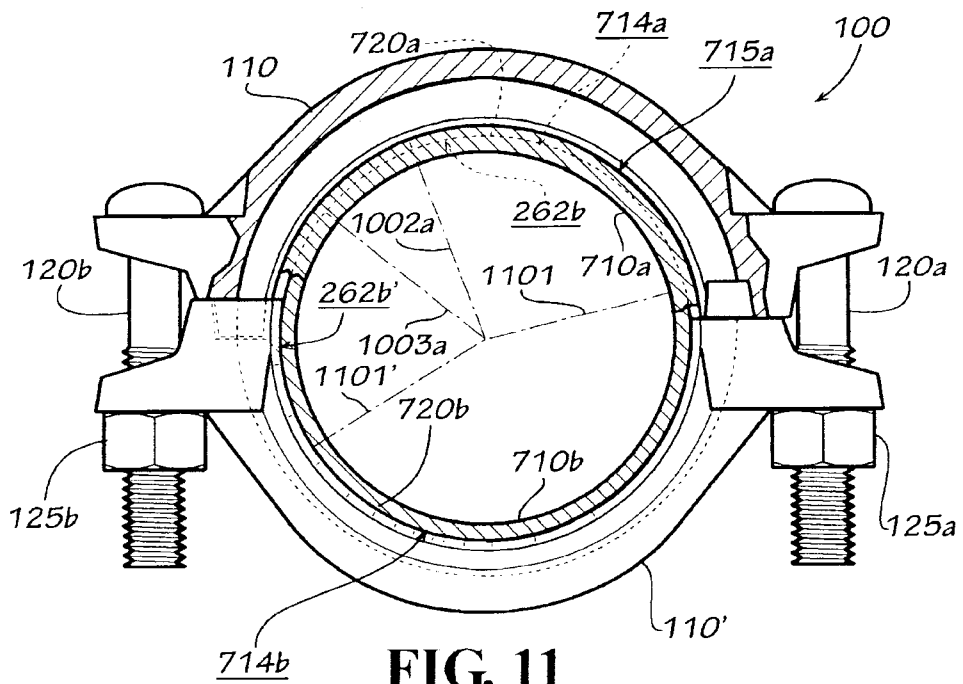

FIG. 11

