

(No Model.)

H. G. M. HOWARD & W. H. SHANNON.  
SURFACE CATTLE GUARD.

No. 455,717.

Patented July 7, 1891.

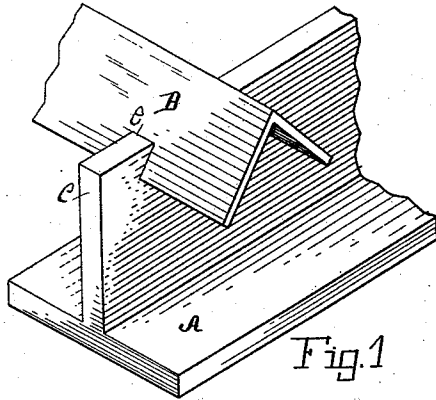

Fig. 1

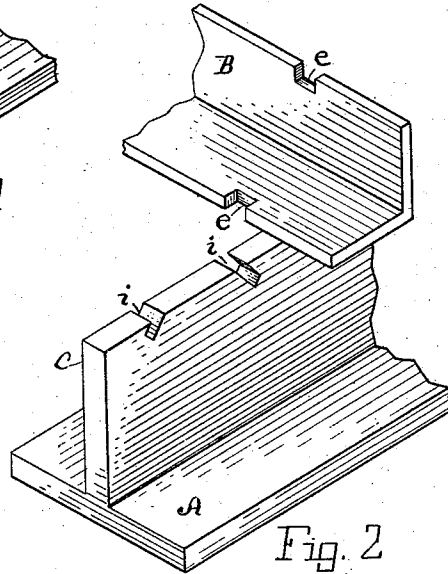

Fig. 2

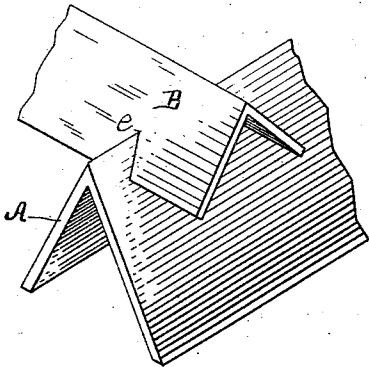

Fig. 3

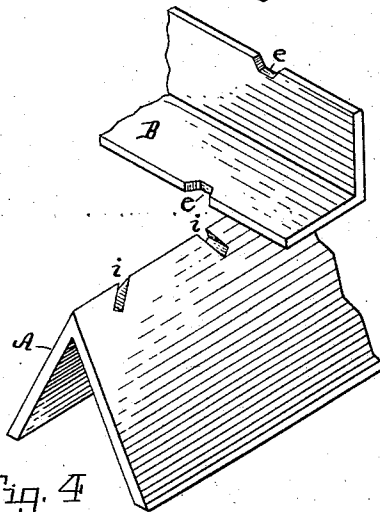

Fig. 4

Witnesses:

Walter S. Wood  
Charles J. ...

Inventor.

Henry G. M. Howard & W. H. Shannon  
By Lucius C. West  
Att'y.

# UNITED STATES PATENT OFFICE.

HENRY G. M. HOWARD AND WILLIAM H. SHANNON, OF KALAMAZOO, MICHIGAN,  
ASSIGNORS OF ONE-THIRD TO THE BUSH SURFACE CATTLE GUARD  
COMPANY, LIMITED, OF SAME PLACE.

## SURFACE CATTLE-GUARD.

SPECIFICATION forming part of Letters Patent No. 455,717, dated July 7, 1891.

Application filed November 11, 1890. Serial No. 371,019. (No model.)

*To all whom it may concern:*

Be it known that we, HENRY G. M. HOWARD and WILLIAM H. SHANNON, citizens of the United States, and residents of Kalamazoo, county of Kalamazoo, State of Michigan, have invented a new and useful Surface Cattle-Guard, of which the following is a specification.

This invention relates to that class of surface cattle-guards in which are employed horizontal bars parallel with the rails of the track and transverse bars at right angles to the rails of the track, which transverse bars support the horizontal bars above the ties of the track.

It further relates to cattle-guards which employ inverted-V-shaped horizontal bars.

The subject of the invention consists in a novel way of attaching the horizontal bars to the transverse bars, all as more particularly described and claimed below.

In the drawings forming a part of this specification, Figure 1 is a broken perspective of the bars attached together; Fig. 2, the same with the bars detached; Fig. 3, a broken perspective showing changes, and Fig. 4 shows the parts in Fig. 3 detached from each other.

Referring to the lettered parts of the drawings, A represents the transverse bars, and B represents the horizontal bars. All the bars B are alike, while the bars A in Figs. 1 and 2 are in the form of an inverted T, and the bars A in Figs. 3 and 4 are in the form of an inverted V. The bars A in all of the figures are provided with downwardly and outwardly slanting mortises *i* in their apex. The bars B in Figs. 1 and 2 are provided with square mortises in each of their lower sides, as at *e*, clearly shown in Fig. 2. The mortises *e* in Fig. 2 are square—that is, they have straight sides—in order to conform to the straight sides of the stem of the inverted-T-shaped transverse bar A, as shown at *c* in Figs. 1 and 2. The mortises *e* in Figs. 3 and 4 flare outward toward the base, thus making the sides of said mortises slanting to conform to the slanting sides of the inverted-V-shaped bars A in said figures. The

bars A and B in all the figures are attached together by placing the bars B on the bars A in proper position, so that the mortises *ee* and *ii* of the respective bars will register with each other, and then a heavy pressure is brought to bear upon the bars B, which pressure forces the mortises to interlock with each other, as in Figs. 1 and 3. In this operation the pressure down on the bars B causes their sides to spring or spread out a little, and thus bind or clamp the engaging mortises of the bars sufficiently tight to make a secure attachment. By this means inverted-V-shaped horizontal bars of a surface cattle-guard are securely attached by a speedy, cheap, and effectual method to the transverse bars which support them.

Of course it will be understood that these guards are to be made in sections, in which are employed a series of the horizontal bars and transverse bars, as in the ordinary manner of constructing and using this class of guards.

Having thus described my invention, what I claim as new, and desire to secure by Letters Patent of the United States, is—

1. In a surface cattle-guard, the combination of transverse bars and inverted-V-shaped longitudinal bars crossing the former-named bars, said bars being provided with interlocking mortises at their points of intersection, substantially as set forth.

2. In a surface cattle-guard, the combination of inverted-V-shaped longitudinal bars provided with mortises in their lower edges at the points where they cross the transverse bars, and transverse bars provided with laterally-slanting mortises in their upper edges conforming to the slant of the sides of the longitudinal bars, substantially as set forth.

In testimony of the foregoing we, the undersigned, have hereunto set our hands in the presence of two witnesses.

HENRY G. M. HOWARD.  
WILLIAM H. SHANNON.

Witnesses:

SAMUEL FOLZ,  
CHAS. FRIEDMAN.