

H. C. BAKER.  
 HASP FASTENER  
 APPLICATION FILED NOV. 7, 1910.

1,061,032.

Patented May 6, 1913.

Fig. 1

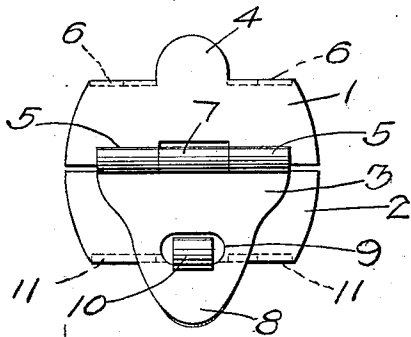

Fig. 2

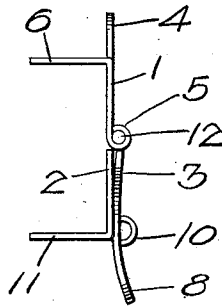

Fig. 3

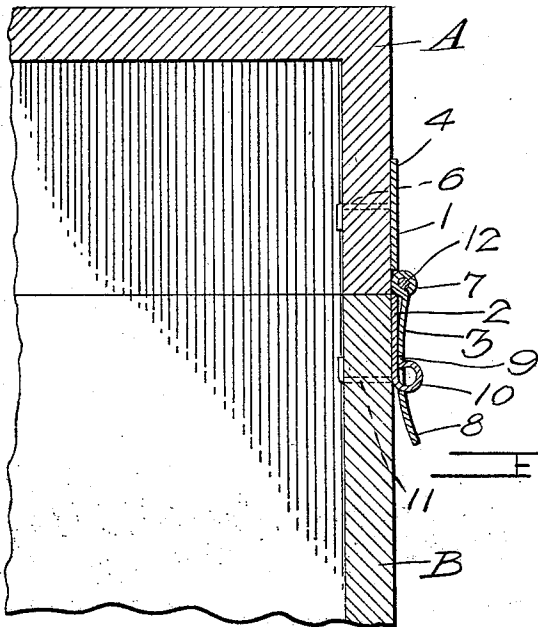

Fig. 4

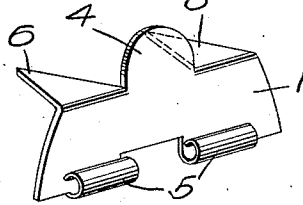

Fig. 5

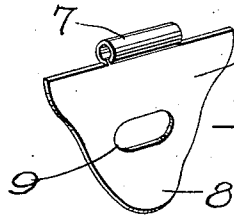

Fig. 6

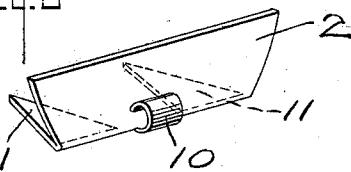
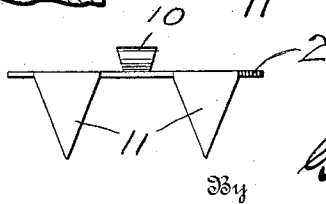

Fig. 7



Witnesses  
*Ed. P. Lusk*  
*A. M. Barth*

By

Inventor  
*H. C. Baker*  
*Wm. Sues*

Attorney

# UNITED STATES PATENT OFFICE.

HARVEY C. BAKER, OF CHICAGO, ILLINOIS, ASSIGNOR TO NATIONAL CLINCH HINGE COMPANY, OF CHICAGO, ILLINOIS, A CORPORATION OF ILLINOIS.

## HASP-FASTENER.

1,061,032.

Specification of Letters Patent.

Patented May 6, 1913.

Application filed November 7, 1910. Serial No. 591,124.

*To all whom it may concern:*

Be it known that I, HARVEY C. BAKER, a citizen of the United States, and a resident of Chicago, in the county of Cook and State of Illinois, have invented certain new and useful Improvements in Hasp-Fasteners, of which the following is a specification, reference being had to the accompanying drawings.

This invention relates to a fastener secured by means of clench points arranged to hold a lid securely to a box against accidental movement.

The primary object of my invention is to provide an inexpensive fastener constructed so that the same may be clenched to a box lid, to positively hold the same to the box.

A further object is to provide a light, neat and simply constructed hasp fastener especially adapted to be used in connection with boxes such as are employed in storing and vending cigars, candy, bottled goods and the like.

A still further object is to provide a hasp fastener having a curved hasp plate arranged for co-action with a resilient locking ear adapted to receive a locking pin.

With these and other objects in view the present invention consists in the combination and arrangement of parts as will be hereinafter more fully described and finally pointed out in the appended claim, it being further understood that changes in the specific structure shown and described may be made within the scope of the claim without departing from the spirit of the invention.

In the accompanying drawings forming a part of this specification, and in which like numerals of reference indicate similar parts in the several views: Figure 1 shows a plan view of a hasp fastener embodying my invention. Fig. 2 shows an edge view thereof. Fig. 3 shows a fragmentary portion of a box and lid secured by means of a hasp fastener constructed according to my invention. Fig. 4 shows a detached detail, in perspective of the carrier plate. Fig. 5 shows a detached detail in perspective of the curved hasp plate. Fig. 6 shows a detached detail in perspective of the ear plate, while Fig. 7 shows an end view of the ear plate.

In the accompanying drawings, B designates the box, and A a connected lid shown

as secured by means of a fastener constructed according to my invention.

My fastener includes a flat elongated carrier plate 1, which along one edge is provided with knuckles 5, while extending from the opposite edge of the carrier plate and at points immediately opposite the knuckles 5, are the clench points 6. Positioned between the clenching points 6 is the plate extension 4 which serves primarily as an ornament.

Held between the knuckles 5, is the knuckle 7 centrally extending from the curved hasp plate 3, this hasp plate being secured to the carrier plate by means of the pin 12 shown in Figs. 2 and 3. This curved hasp plate 3 is approximately triangular in outline as disclosed in Fig. 5, and at a point opposite the knuckle 7 has a slot or aperture 9. Arranged for co-action with the hasp plate 3, is the ear plate 2, along one edge, being provided with the clench points 11, while positioned between these clench points is the resilient tubular ear 10 which decreases in width toward its base, as shown in Fig. 7. The tubular ear as shown extends in a direction opposite to the clench points.

The parts are so arranged and spaced that when properly secured, some force is necessary to carry the hasp plate 3 over the resilient ear 10, which ear in the securing and releasing operation of the hasp plate, is sprung slightly out of position, so that in its secured position, the hasp plate 3 is securely held upon the tubular resilient ear 10. As the upper surface of the ear 10 is wider than its lower portion as shown in Fig. 7, the hasp plate is held under spring tension in engagement with the ear 10, in its locked condition. As the lower operating end 8 of the hasp plate curves away from the surface to which the ear plate is secured, the hasp plate can be readily grasped in operating the same.

Should it be desired to lock the hasp, it would simply be necessary to carry a sealing wire through the tubular ear 10, so that the hasp could only be opened after the sealing member had been destroyed. It is of course understood that the keeper of a suitable padlock could also be used in securing the hasp plate in position.

The fastener is secured to the box and lid by hand or by machinery, in such a manner

as to insure the clench points passing through the wood, the ends then being clenched. This insures both members being firmly secured.

5 The three members described as comprising my clench point may each be formed entire at one operation, being stamped from sheet metal.

10 A hasp fastener constructed according to my invention, is simple and inexpensive in construction, and both durable and efficient in operation.

15 Having thus described my said invention, what I claim as new and desire to secure by United States Letters Patent is:

In a fastener, the combination of a carrier plate having a hasp hinged thereto, said

hasp being provided with a slot; a keeper plate formed from sheet metal and having at one edge spaced clench points disposed at an angle to the plane of the plate, the material between the points being curled up from the edge of the said ear plate with its end disposed over the intermediate portion of the plate, the said curled portion being adapted to frictionally engage the edge of the said slot. 20 25

In testimony whereof I affix my signature, in presence of two witnesses.

HARVEY C. BAKER.

Witnesses:

CHARLOTTE DOOLITTLE,  
ANDREW J. REDMOND.

Copies of this patent may be obtained for five cents each, by addressing the "Commissioner of Patents, Washington, D. C."