



US00D538433S

(12) **United States Design Patent** (10) **Patent No.:** **US D538,433 S**
Lorimer et al. (45) **Date of Patent:** **** Mar. 13, 2007**

(54) **DOCKING DEVICE FOR A MEDICAL INSTRUMENT**

(75) Inventors: **Kevin Lorimer**, Oxon (GB); **John Griffiths**, Derbyshire (GB); **David Wykes**, Seattle, WA (US); **Ian Heseltine**, London (GB); **Philip Stankus**, West Sussex (GB); **Oliver Bishop**, Hampshire (GB); **Nick Smart**, West Sussex (GB)

(73) Assignee: **Oxford Biosensors Limited**, Yarnton (GB)

(**) Term: **14 Years**

(21) Appl. No.: **29/204,449**

(22) Filed: **Apr. 29, 2004**
(Under 37 CFR 1.47)

(51) **LOC (8) Cl.** **24-01**
(52) **U.S. Cl.** **D24/169**
(58) **Field of Classification Search** D24/169,
D24/111; D13/107, 108; D14/251, 253, 434;
128/897, 920; 600/300; 320/114, DIG. 35
See application file for complete search history.

(56) **References Cited**

U.S. PATENT DOCUMENTS

D434,142 S * 11/2000 Cheney et al. D24/111
6,524,240 B1 * 2/2003 Thede 600/300
6,534,953 B2 * 3/2003 Shirakawa 320/114

OTHER PUBLICATIONS

Will Colon, "Better By Design: The Humanising Technology Project," "Medical Device Technology," Nov. 2003, Advanstar Publication, United Kingdom.
"Better by Design: The Humanising Technology Project," "Medical Device Technology," Nov. 2003, Advanstar Publication, United Kingdom.

"Focus on Technology," "Talking Sense: The Oxford Biosensors Newsletter," Spring/Summer 2004, See p. 3 of pp. 1-4, Oxford Biosensors, Yarnton, United Kingdom.
Will Colon, "Microanalysis: Biosensors at the Point of Care," "MST News: Biomicrotechnology," Feb. 2004, vol. No. 1/04.
"From Technical Development to Commercial Reality," "News Review: The Operating Theatre Journal," Jan./Feb. 2004, 27.5, Humanising Technology.
"Six on a Strip," "Medical Laboratory World," Feb. 2004, vol. 13, The Design Council.
"Multi-Parameter, Hand-Held POC System," "Clinical Laboratory International," Feb./Mar. 2004, vol. 36.

(Continued)

Primary Examiner—Louis S. Zarfes
Assistant Examiner—Daniel Yu

(74) *Attorney, Agent, or Firm*—George E. Haas; Quarles & Brady LLP

(57) **CLAIM**

The ornamental design for docking device for a medical instrument, as shown and described.

DESCRIPTION

In a preferred embodiment, the nature of this product is as a device for holding a medical instrument that is useful for monitoring or treating medical patients.

FIG. 1 is a perspective view of a docking device for a medical instrument embodying the new design;
FIG. 2 is a front elevational view thereof;
FIG. 3 is a rear elevational view thereof;
FIG. 4 is a top plan view thereof;
FIG. 5 is a bottom plan view thereof;
FIG. 6 is a left side elevational view thereof; and,
FIG. 7 is a right side elevational view thereof.

1 Claim, 4 Drawing Sheets

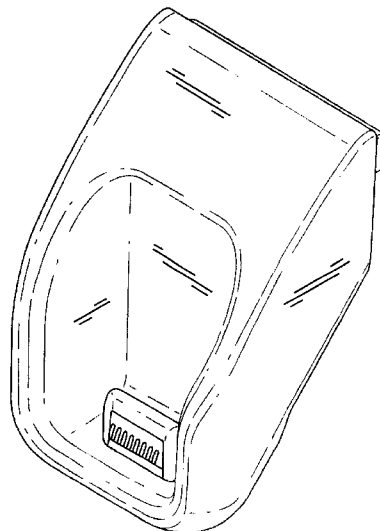

OTHER PUBLICATIONS

“From Technical Development to Commercial Reality,”
“Cardiology News,” Feb./Mar. 2004; vol. 13, Humanising
Technology.

“UK Design Council Helps Diagnostic Product Break New
Ground,” “European Medical Device Manufacturer,” Mar./
Apr. 2004, vol. 71; The Design Council.

“Multisense Cardiac Risk Test,” “Cardiology News Product
Guide,” 2004/2005, vol. 9.

“Multi-Parameter Analysis,” “Inside Hospitals,” Apr. 2004,
vol. 26.5; Humanising Technology.

“Making Perfect Sense,” WWW.LABNEWS.CO.UK, Jul.
2004, United Kingdom.

* cited by examiner

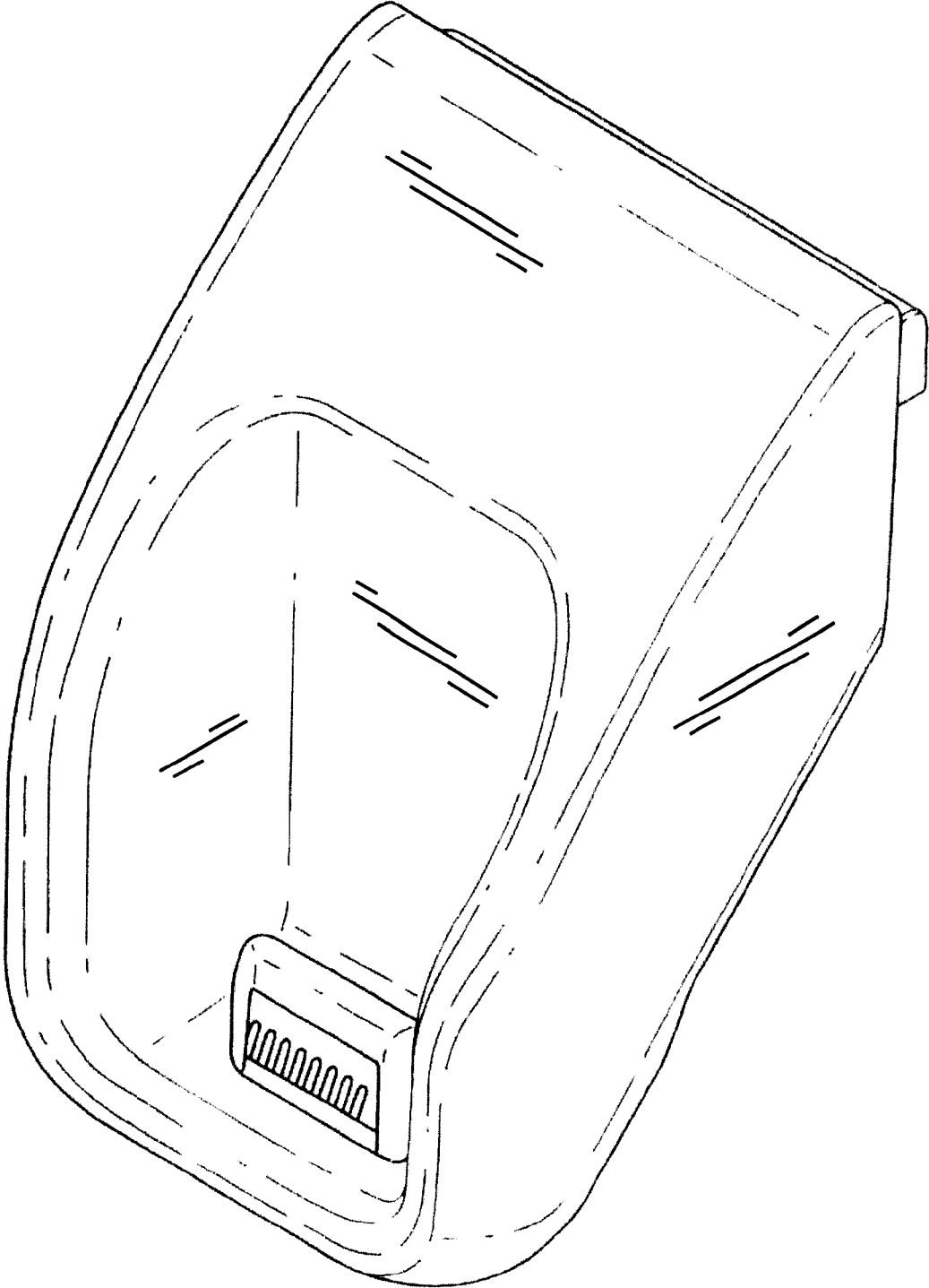

Fig. 1.

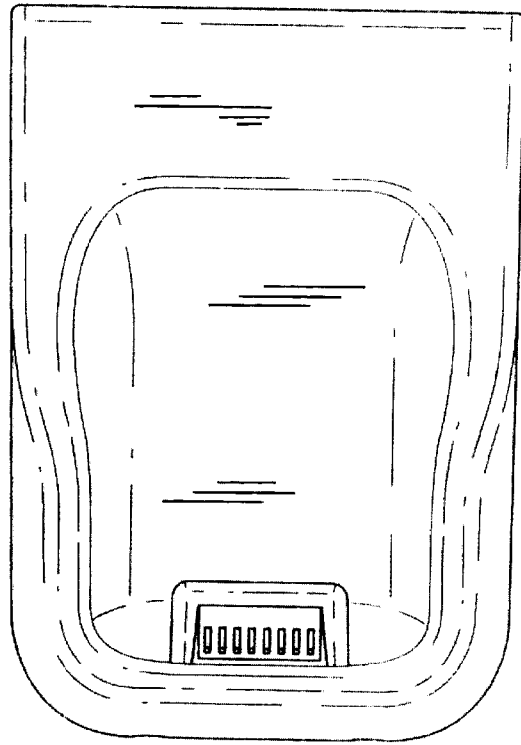

Fig. 2.

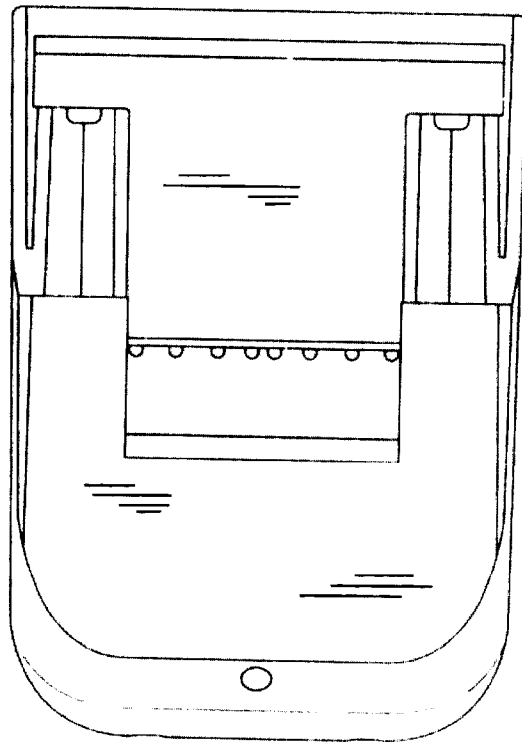

Fig. 3.

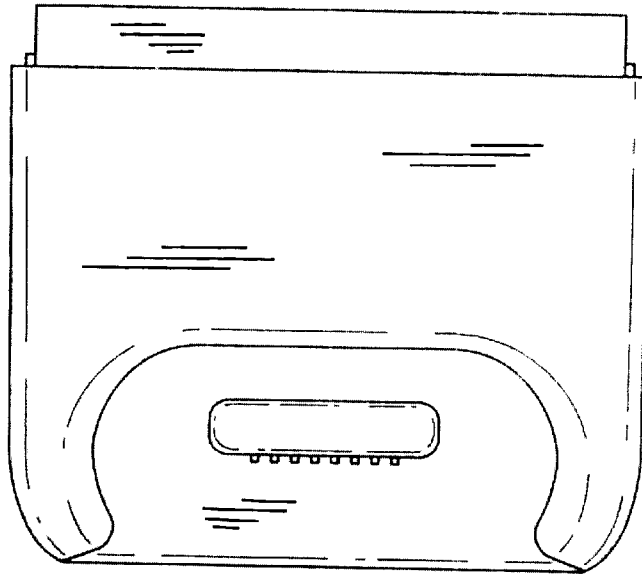

Fig. 4.

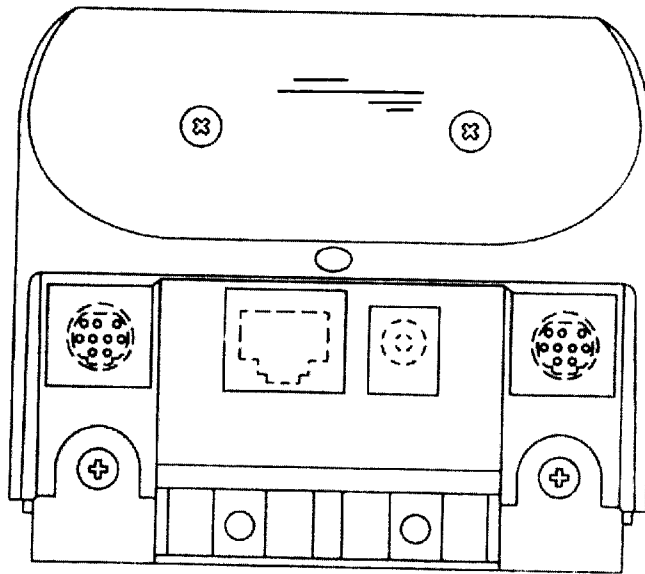

Fig. 5.

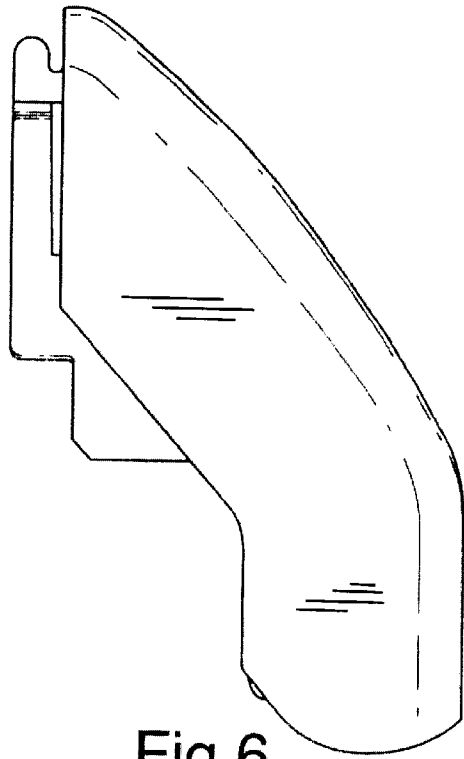

Fig.6.

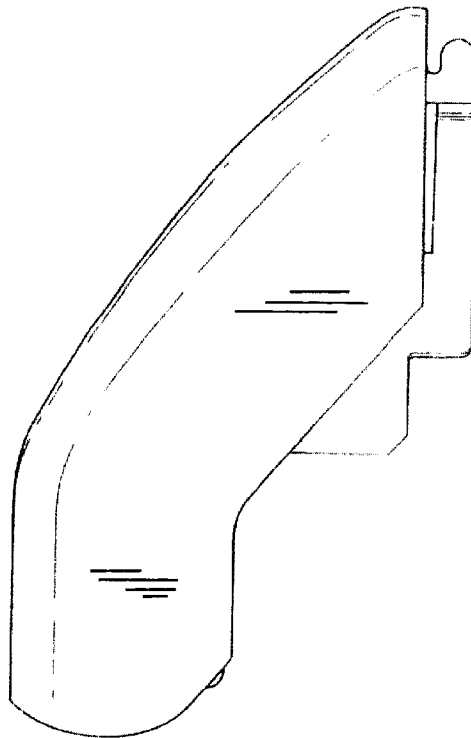

Fig.7.