



INTERNATIONAL APPLICATION PUBLISHED UNDER THE PATENT COOPERATION TREATY (PCT)

<p>(51) International Patent Classification <sup>5</sup> : <b>H04M 1/02</b></p>	<p><b>A1</b></p>	<p>(11) International Publication Number: <b>WO 94/01958</b> (43) International Publication Date: 20 January 1994 (20.01.94)</p>
<p>(21) International Application Number: PCT/SE93/00611 (22) International Filing Date: 2 July 1993 (02.07.93) (30) Priority data: 9202086-6 3 July 1992 (03.07.92) SE (71) Applicant (for all designated States except US): TELEFON- AKTIEBOLAGET LM ERICSSON [SE/SE]; S-126 25 Stockholm (SE). (72) Inventor; and (75) Inventor/Applicant (for US only) : EWERT, Lena [SE/SE]; Kvarngärdesgatan 1A, S-412 73 Göteborg (SE). (74) Agents: LÖVGREN, Tage et al.; Telefonaktiebolaget LM Ericsson, S-126 25 Stockholm (SE).</p>		<p>(81) Designated States: AU, JP, US, European patent (AT, BE, CH, DE, DK, ES, FR, GB, GR, IE, IT, LU, MC, NL, PT, SE).  <b>Published</b> <i>With international search report.</i> <i>In English translation (filed in Swedish).</i></p>

(54) Title: ARRANGEMENT FOR SIMPLIFYING ORDERING OF TELECOMMUNICATION SERVICES

(57) Abstract

The present invention relates to an arrangement for simplifying communication between a user and a telecommunication unit connected to a telephone network. The arrangement includes at least one options menu (32, 42; 104, 106) connected to the telephone unit and presenting selectable options. The arrangement also includes at least one selection control unit (44; 108) which is connected to the options menu and by means of which movement of a service indicator is effected in the menu and options are selected. According to the invention, the menu is a visual (32; 104) and/or auditive (42; 106) menu and the selection control unit is auditive (44, 108).

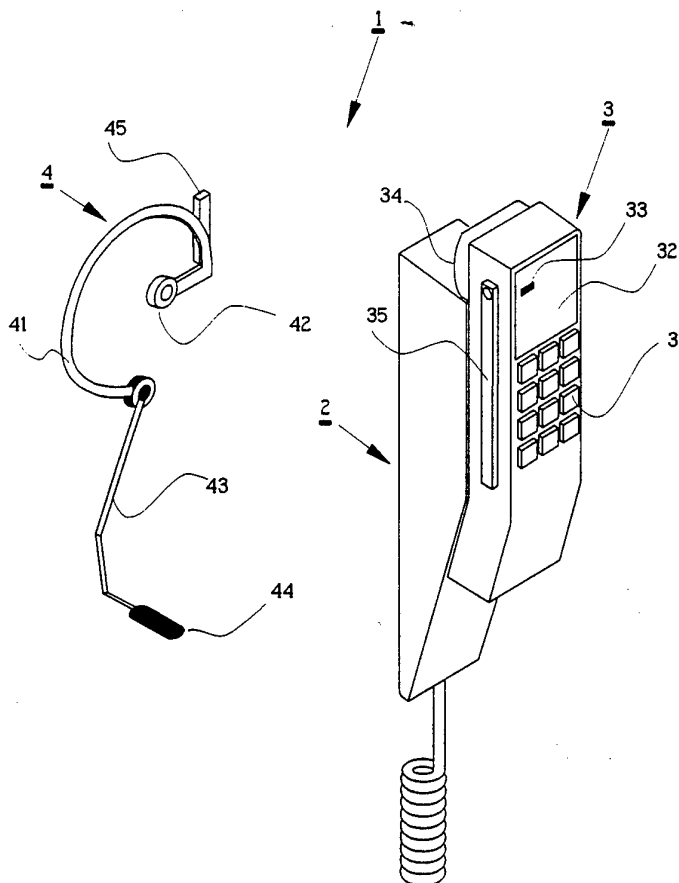

**FOR THE PURPOSES OF INFORMATION ONLY**

Codes used to identify States party to the PCT on the front pages of pamphlets publishing international applications under the PCT.

AT	Austria	FR	France	MR	Mauritania
AU	Australia	GA	Gabon	MW	Malawi
BB	Barbados	GB	United Kingdom	NE	Niger
BE	Belgium	GN	Guinea	NL	Netherlands
BF	Burkina Faso	GR	Greece	NO	Norway
BG	Bulgaria	HU	Hungary	NZ	New Zealand
BJ	Benin	IE	Ireland	PL	Poland
BR	Brazil	IT	Italy	PT	Portugal
BY	Belarus	JP	Japan	RO	Romania
CA	Canada	KP	Democratic People's Republic of Korea	RU	Russian Federation
CF	Central African Republic	KR	Republic of Korea	SD	Sudan
CG	Congo	KZ	Kazakhstan	SE	Sweden
CH	Switzerland	LI	Liechtenstein	SI	Slovenia
CI	Côte d'Ivoire	LK	Sri Lanka	SK	Slovak Republic
CM	Cameroon	LU	Luxembourg	SN	Senegal
CN	China	LV	Latvia	TD	Chad
CS	Czechoslovakia	MC	Monaco	TG	Togo
CZ	Czech Republic	MG	Madagascar	UA	Ukraine
DE	Germany	ML	Mali	US	United States of America
DK	Denmark	MN	Mongolia	UZ	Uzbekistan
ES	Spain			VN	Viet Nam
FI	Finland				

## ARRANGEMENT FOR SIMPLIFYING ORDERING OF TELECOMMUNICATION SERVICES

**Technical Field**

5

The present invention relates to an arrangement for simplifying communication between a user and a telecommunication unit connected to a telephone network. Connected to the telecommunication unit is an options menu which presents the options that can be selected. The arrangement also includes a selection control unit by means of which movement in the menu is effected and different options can be selected.

10

**Background Art**

In order to be able to meet the large number of telephony services that will become available in the future, it will be necessary to provide a simple interface between a user and a telecommunication unit connected to a telephone network. For instance, EP 463,856 teaches a mobile telephone which includes an options menu in which telephone service options are presented visually. These telephone services can be chosen either by pressing keys or buttons on the mobile or by manoeuvring other manoeuvring devices provided on the mobile, for instance a thumb wheel. Since the driver of a vehicle must often concentrate solely on his/her driving, it is essential in the field of mobile telephony to eliminate all external, disturbing procedures, such as the procedures taken when calling a subscriber. One problem with present-day known technology resides in the difficulty experienced in viewing the options menu and/or making a selection with the aid of the manoeuvring device during an ongoing call/conversation at the same time, while driving the vehicle. The aforesaid problems have been intensified by recent proposals to forbid the use of mobile telephones while driving a motor vehicle. At

15  
20  
25  
30  
35

present, intensive developments are being undertaken within the technical field of user-friendly interfaces, and one solution of the many solutions proposed resides in an auditive interface known under the  
5 description "Bank queries/transactions by telefon". The problem with this type of interface is that it is necessary for the user to insert a code or to confirm a selection manually, for instance with the aid of a keypad. In the case of some professional groups or  
10 occupations, such as rescue services, police or security guards for instance, it is extremely important that the people involved are able to work with their hands while undisturbed and without needing to change their line of vision while requesting a particular  
15 telephone service.

#### **Disclosure of the Invention**

The object of the present invention is to simplify the  
20 ordering of telephony services. This object is achieved in accordance with the present invention by combining or replacing the existing visual menu of a telecommunication unit with an auditive options menu from which the telephone services available on the  
25 menu are recited audibly. The menu control unit is an auditive unit, i.e. receives and responds to voice commands. The invention is characterized by the characteristic features set forth in the following Claims.

#### **30 Brief Description of the Drawings**

The invention will now be described in more detail with reference to exemplifying embodiments thereof and also with reference to the accompanying drawings, in  
35 which

Figure 1 is a perspective view of a mobile telephone which includes an inventive auditive options menu and an auditive menu control unit;

Figure 2 illustrates in perspective and in two separate illustrations a portable telephone which includes an inventive auditive menu control unit and an auditive menu; and

5 Figure 3 is a block diagram illustrative of an inventive telephone.

#### **Best Mode of Carrying Out the Invention**

10 Figure 1 illustrates a mobile telephone, referenced generally 1, for use within a cellular mobile telephone network. The mobile telephone includes an adapter unit, generally referenced 2, which is mounted in a motor vehicle, and a mobile telephone unit, generally  
15 referenced 3, which rests against the adapter unit. The mobile telephone 1 also includes a communication unit, generally referenced 4, which communicates with the telephone unit 3 through the agency of cordless transmission.

20

Although not shown in Figure 1, the adapter unit 2 includes a unit charging device, and magnets are mounted on that side of the adapter which faces towards the telephone unit 3 and function to hold the  
25 telephone unit in its charging position.

The telephone unit 3 presents on that side of the unit which is remote from the adapter unit a keypad 31 which is comprised of twelve buttons or keys by means  
30 of which standard services are ordered and put into effect within the context of telephony, such as the manual dialling of a telephone number for instance. In order to meet the many telephone services that are already available and also those which can be expected  
35 to be added in the future, the fixed unit includes a visible menu display 32 on which different selectable telephone services, i.e. service options, can be presented in addition to the aforesaid standard

services. The visual menu display will be large enough to display, for instance, five telephone services simultaneously. A cursor 33 marks one of the five visible services. The options menu is a scrolling menu, i.e. a menu in which additional telephone services can be made visible, by moving the cursor up or down, i.e. in a direction away from or towards the earlier mentioned keypad 31. The telephone unit 3 also includes a speech receiving device (not shown in Figure 1) and a conventional sound reproduction 34 on that side of the telephone unit which lies proximal to the adapter unit 2. Mounted on one of the long sides of the telephone unit 3, between the two aforesaid sides, is a first antenna 35 which functions to transmit signals to and to receive signals from a second antenna 45 mounted on the communication unit 4.

The communication unit 4 includes a resilient, curved member 41. Mounted on one end of the curved member 41 is a so-called auditive options menu 42, which is described in more detail further on, while the other end of the curved member 41 carries an attachment arm 43 to which an auditive menu control unit 44 is attached, this unit also being described in more detail further on. The communication unit 4 also carries the aforesaid second antenna 45 by means of which signals are transmitted to and received from the aforesaid first antenna 35.

The auditive menu 42 and the menu control unit 44 are both connected electrically to the second antenna 45. The electrical connections extend within the curved member 41 and the attachment arm 43 respectively and are therefore not visible in Figure 1. In the illustrated embodiment, the curved member 41 is intended to be fitted over the user's ears and fastened so that the sound emitted by the auditive options menu will be heard clearly by the user. The auditive options menu 42 includes a loudspeaker and a menu processor in

which data relating to the telephone service indicated by the cursor 33 at that moment is stored, and converts this data to speech signals which can be heard in the loudspeaker. The data fed to the menu processor is received from the visual menu over the aforesaid antennas 35, 45. Thus, the earlier mentioned telephone services presented visually on the display are presented in speech form in the auditive menu 42. A sound marker in the auditive menu has the same function as the aforesaid cursor 33, i.e. the user is able to discern when the cursor has moved in the menu, with the aid of an audible tone. The nature of respective telephone services presented in the auditive menu is the same as that presented on the visual menu 32. Both the visual and the auditive menu are constructed hierarchically, i.e. they are comprised of rank ordered menus, as described in more detail further on.

The auditive menu control unit 44 is adjustable in relation to the curved member 41, and can be moved to a position in which said unit will clearly understand the sounds uttered by the user. The auditive control unit 44 includes a microphone and an audio processor, which converts the sound incoming from the microphone to data form. The data is sent from the audio processor to the visual menu over the aforesaid antennas 35, 45. Thus, the cursor 33 and the marker can be controlled by both the visual menu 32 and the auditive menu 42 with the aid of voice commands, i.e. the options are read-out from the auditive menu at the same time as the cursor 33 moves through the visual menu.

The communication unit 4 can be used as an extension of the aforesaid speech receiving device and the sound reproduction device 34 during the course of an ongoing call. According to the invention, the communication unit 4 can also be used to control the visual options

menu, as before described. The switch between the audio and visual use of the arrangement is effected with the aid of voice commands, as described in more detail further on. The coaction between the various components of the inventive arrangement are also described below, with reference to a block schematic.

An example of how the inventive arrangement can be used to call a subscriber will now be described, although by way of illustration only:

- The user initiates activation of the menu control with a first voice command START.
- The cursor 33 is then stepped in a first direction away from the traditional keypad 31, by issuing a second voice command UP. Alternatively, the cursor 33 is stepped in the other direction, towards the traditional keypad 31, by issuing a third voice command DOWN. The marker in the auditive menu 42 will move at the same time as the cursor moves in a main menu on the visual menu display 32, wherewith the telephone services that coincide with the position of the audio-menu marker are read-out to the user after the tone signal from the marker.
- The telephone service desired is located in the menu, which in the illustrated case is the service "directory".
- The user selects the "directory" service, with a fourth voice command SELECT.
- A first submenu containing subscriber names in alphabetical order is presented on the visual menu display 32 at the same time as the name to which the cursor 33 and the marker point are read-out from the auditive menu 42.
- A search is made through the option menus 32, 42 in the same way as that described above, in response to the second and/or third voice commands.
- The name required is located.
- The user selects the name desired through the fourth voice command SELECT.



- 5       - A second submenu containing personal data, for instance addresses and telephone numbers, is shown on the visual menu display 32, at the same time as the data to which the cursor 33 and the marker point is read-out from the auditive menu into the loudspeaker 42.
- 10       - The cursor/marker are moved to the desired telephone number, in the aforescribed manner.
- 10       - The user orders the telephone unit to call the indicated number, through a fifth voice command CALL.
- 15       - When the call has been connected, the user orders deactivation of the menu control through a sixth voice command STOP, wherewith the communication unit 4 again functions as an extension of the sound reproduction and speech receiving device of the telephone unit.

20       It will be understood that the aforescribed embodiment may be modified within the scope of the invention. For instance, the aforementioned voice commands can be optimized to a few common commands. For instance, the voice commands SELECT and CALL can be replaced with the single command YES. The described menu and audio processors may be mounted in the telephone unit 3 instead of in the communication unit 4, thereby reducing the size of the latter. The communication unit 4 may include an auditive options menu and/or control unit firmly mounted on the vehicle chassis. The auditive options menu may, for instance, have the form of an earmuff while the auditive control unit may, for instance, have the form of a stocking microphone. The aforesaid tone from the marker in the auditive menu may be excluded and replaced, for instance, solely with the spoken message.

35       Figure 2 illustrates another exemplifying embodiment of the invention. The embodiment illustrated in Figure 2 comprises a portable telephone, generally referenced 100, which may be used in an office environment for instance. The telephone is shown in two different

views, namely a view towards the rear surface 101, i.e. the surface that lies distal from the user in use, and a view towards the front surface 102, i.e. the surface that lies proximal to the user in use.

5 Mounted on the front surface 102 is a twelve-button keypad 103 by means of which standard services within the telephony field can be instigated, such as the manual selection of a telephone number for instance. Mounted on the rear surface 101 of the telephone is a  
10 visual menu display of the kind described with reference to the earlier embodiment. A cursor 105 points to the service options available on the menu, which may have the following nature:

- The user wishes to leave a short-absence message.
- 15 - The user wishes to leave a message to the effect that he is ill, away on business or on vacation.
- The user wishes to enquire whether he has been paged during his/her absence.
- The user chooses not to accept one or more of the  
20 incoming calls.

The front surface 102 of the telephone 100 shown in Figure 2 incorporates an auditive options menu 106, shown in broken lines, which includes a loudspeaker  
25 107 and a menu processor, not shown in Figure 2. In principle, the auditive menu 106 functions in the same manner as the auditive menu described with reference to the earlier embodiment, i.e. the menu processor reads-in data from the visual options menu 104 and  
30 converts this data to audible speech with the aid of the loudspeaker 107. The front surface 102 of the telephone 100 further embodies an auditive control unit 108, shown in broken lines in Figure 2, a microphone 109 and an audio processor, not shown in Figure  
35 2. In principle, the auditive control unit 108 functions in the same manner as the control unit described with reference to the earlier embodiment, i.e. the audio processor reads-in audible speech from the microphone 109 and converts the sound to data signals

that are used to control both the visual menu 104 and the auditive menu 106, in the same way as that described with reference to the earlier embodiment.

- 5 A brief explanation will now be given of the way in which one of the aforesaid telephone services can be utilized with the aid of the inventive arrangement:
- The menu control is activated by means of a voice command of the same type or a similar type to that earlier mentioned, and the user selects the service "Short Absence" from the options menus 104, 106.
  - 10 - A submenu which lists different time options, such as 15, 30 or 45 minutes for instance, is shown on the visual menu 104 and is read out from the auditive menu 15 106 in the same manner as that earlier described.
  - Using a voice command, the user searches for and selects in the menus 104, 106 the anticipated duration of his/her absence, wherewith all incoming calls are referred to a central exchange during this time 20 period.
  - Menu control is deactivated.

The embodiment illustrated in Figure 2, also includes a manoeuvring device 110 of known kind, indicating 25 that the inventive auditive control of the options menus may also be combined, for instance, with a known electromagnetic manoeuvring means. In this case, the aforesaid voice commands may coincide in name and number with those given on the manoeuvring means 110, 30 so as to enable both control units to be used in parallel.

Figure 3 is a functional block schematic which illustrates an exemplifying embodiment of an inventive 35 telephone set. The arrangement includes a central unit to which there is connected a display, a menu processor and an audio processor. The display constitutes the earlier mentioned visual options menu. A loud-speaker is connected to the menu processor and

together the two units constitute the earlier mentioned auditive options menu. A microphone is connected to the audio processor and the two units together constitute the earlier mentioned auditive options control unit. The menu processor and the audio processor together with the loudspeaker and the microphone handle conversion of data to sound, and vice versa. The central unit handles the transport of data between the different units, namely between the visual menu, the auditive menu and the auditive selection control unit. It should be mentioned that the illustrated block schematic shall only be seen as an example of an inventive arrangement. It will be obvious to the person skilled in this art that changes can be made without transgressing from the concept of the inventive arrangement.

It will be understood that the aforescribed and illustrated embodiments of the invention can be modified and varied within the scope of the present invention. The telephone unit can be optionally connected to a fixed telephone network, a cellular, cordless telephone network for internal environments or a mobile telephone network for external environments. Furthermore, the combination comprising control unit and visual and/or auditive options menu may be made selective, provided that the combination is kept within the scope of the invention. Since it is often easiest for the user of auditive units to recognize his/her own voice, it is conceivable to replace the synthetic voice in the auditive menu with, for instance, a recording of the user's own voice. It will be obvious to the skilled person that the auditive control unit can be constructed to receive solely the user's voice, which can be an important feature from the aspect of reliability and security. Naturally, the type of voice command and the number of voice commands required to locate and perform the correct telephone service may vary in accordance with the requirements

of the designer. It will be evident that the invention is not restricted to the aforescribed and illustrated exemplifying embodiments thereof and that modifications can be made within the scope of the following

5 Claims.

## CLAIMS

1. An arrangement for simplifying communication between a user and a telecommunication unit (1; 100) connected to a telephone network, wherein the arrangement includes at least one options menu (32, 42; 104, 106) which is connected to the telecommunications unit and which presents a number of telephone service options, and at least one selection control unit (44; 108) which is connected to said at least one menu and by means of which the options contained in the menu can be indicated and selected, c h a r a c -  
t e r i z e d in that the options menu is visual (32; 104), i.e. visible, and/or auditive (42; 106), i.e. sound transmitting, and in that the selection control unit (44; 108) is auditive, i.e. functions to receive voice commands.

2. An arrangement according to Claim 1, c h a r -  
a c t e r i z e d in that the visible menu (32; 104) includes a cursor (33; 105) which can be moved to the various options in the options menu with the aid of a voice command issued to the selection control unit (44; 108), so that an indicated option can be selected by issuing another voice command.

3. An arrangement according to Claim 1 or 2, c h a r a c t e r i z e d in that the auditive options menu (42; 106) includes a marker which can be moved to the various options listed in the options menu with the aid of a voice command issued to the selection control unit (34; 108), so as to enable an indicated option to be selected with the aid of another voice command.

35

4. An arrangement according to Claim 2, c h a r -  
a c t e r i z e d in that the visual options menu (32; 104) is a so-called scrolling menu, so that the total number of options listed will exceed the number

of options that are visible on the menu at any one time.

5. An arrangement according to Claim 1, 2, 3 or 4, characterized in that the options menu (32, 42; 104, 106) is hierarchically constructed and includes at least two ranking levels.

6. An arrangement according to Claim 1, 2, 3, 4 or 5, characterized in that the arrangement includes a menu memory which belongs to the auditive menu (42; 106) and in which the user may program his/her own voice so as to achieve more reliable sound reproduction.

15

7. An arrangement according to Claim 1, 2, 3, 4, 5 or 6, characterized by an audio memory belonging to the auditive selection control unit (44; 108), in which the user is able to program his/her own voice so as to obtain a more reliable sound reception.

20

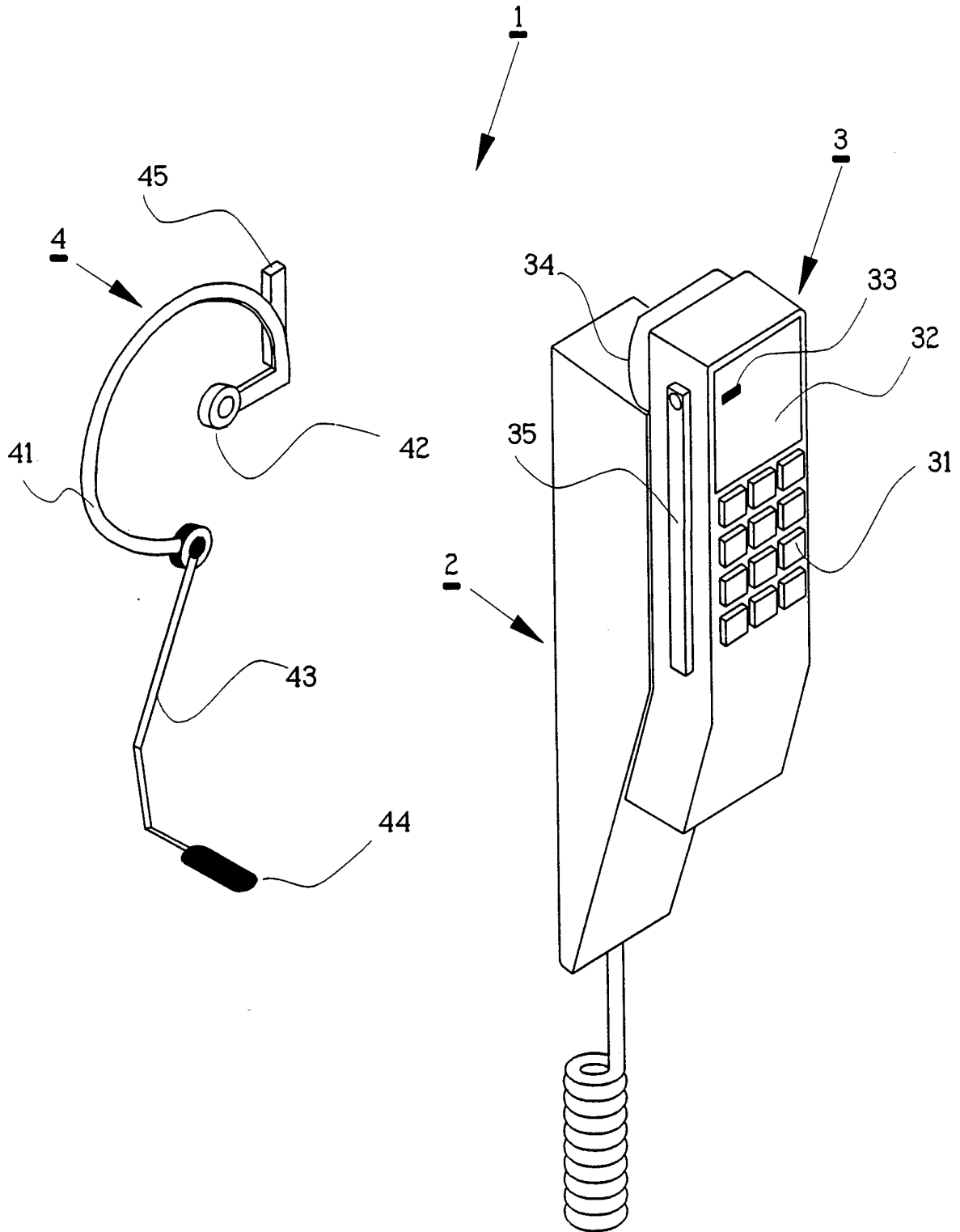

FIG. 1



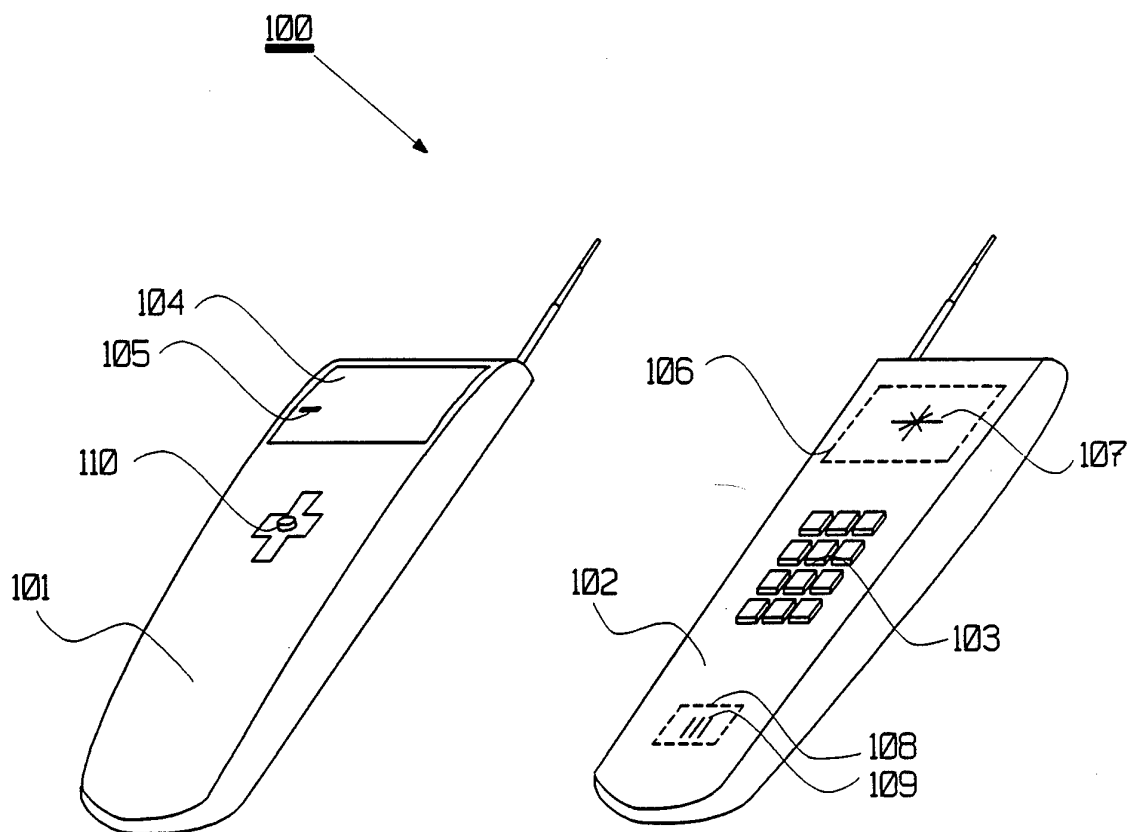

FIG. 2

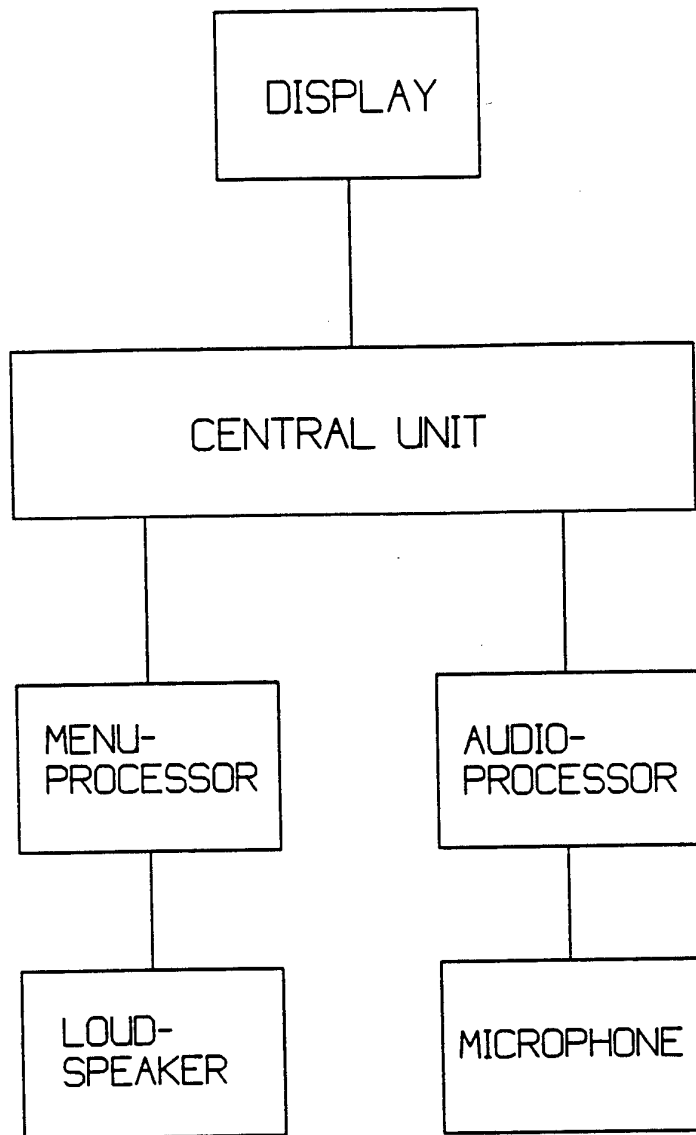

FIG. 3

## INTERNATIONAL SEARCH REPORT

International application No.

PCT/SE 93/00611

A. CLASSIFICATION OF SUBJECT MATTER		
IPC5: H04M 1/02 According to International Patent Classification (IPC) or to both national classification and IPC		
B. FIELDS SEARCHED		
Minimum documentation searched (classification system followed by classification symbols)		
IPC5: H04M		
Documentation searched other than minimum documentation to the extent that such documents are included in the fields searched		
SE,DK,FI,NO classes as above		
Electronic data base consulted during the international search (name of data base and, where practicable, search terms used)		
C. DOCUMENTS CONSIDERED TO BE RELEVANT		
Category*	Citation of document, with indication, where appropriate, of the relevant passages	Relevant to claim No.
A	EP, A2, 0463856 (NOKIA MOBILE PHONES LTD), 2 January 1992 (02.01.92), figures 1-3, abstract --	1-7
A	EP, A2, 0279233 (SIEMENS AKTIENGESELLSCHAFT), 24 August 1988 (24.08.88), figures 1-2, abstract --	1-7
A	US, A, 4782522 (DIETER KRAMER ET AL), 1 November 1988 (01.11.88), figure 2, abstract -- -----	1-7
<input checked="" type="checkbox"/> Further documents are listed in the continuation of Box C. <input checked="" type="checkbox"/> See patent family annex.		
* Special categories of cited documents: "A" document defining the general state of the art which is not considered to be of particular relevance "E" earlier document but published on or after the international filing date "L" document which may throw doubts on priority claim(s) or which is cited to establish the publication date of another citation or other special reason (as specified) "O" document referring to an oral disclosure, use, exhibition or other means "P" document published prior to the international filing date but later than the priority date claimed "T" later document published after the international filing date or priority date and not in conflict with the application but cited to understand the principle or theory underlying the invention "X" document of particular relevance: the claimed invention cannot be considered novel or cannot be considered to involve an inventive step when the document is taken alone "Y" document of particular relevance: the claimed invention cannot be considered to involve an inventive step when the document is combined with one or more other such documents, such combination being obvious to a person skilled in the art "&" document member of the same patent family		
Date of the actual completion of the international search		Date of mailing of the international search report
20 August 1993		03 -09- 1993
Name and mailing address of the ISA/ Swedish Patent Office Box 5055, S-102 42 STOCKHOLM Facsimile No. +46 8 666 02 86		Authorized officer Michael Felhendler Telephone No. +46 8 782 25 00

## INTERNATIONAL SEARCH REPORT

International application No.

PCT/SE 93/00611

C (Continuation). DOCUMENTS CONSIDERED TO BE RELEVANT		
Category*	Citation of document, with indication, where appropriate, of the relevant passages	Relevant to claim No.
A	US, A, 4506377 (NORIMASA KISHI ET AL), 19 March 1985 (19.03.85), figures 1-2,4,6, abstract  -----	1-7

**INTERNATIONAL SEARCH REPORT**  
 Information on patent family members

30/07/93

International application No.  
 PCT/SE 93/00611

Patent document cited in search report	Publication date	Patent family member(s)	Publication date
EP-A2- 0463856	02/01/92	NONE	
EP-A2- 0279233	24/08/88	NONE	
US-A- 4782522	01/11/88	DE-A, C- 3607727 DE-A, C- 3607728 EP-A- 0230607 DE-A- 3704738 DE-A- 3705238	03/09/87 30/07/87 05/08/87 25/08/88 01/09/88
US-A- 4506377	19/03/85	EP-A, B- 0078016	04/05/83