

[54] **PACKAGE FOR NEEDLES**  
 [72] Inventor: **Donald Saunders**, Astwood Bank, near Redditch, England  
 [73] Assignee: **The British Needle Company Limited**, Redditch, Worcestershire, England  
 [22] Filed: **Oct. 17, 1969**  
 [21] Appl. No.: **867,279**

3,396,833 8/1968 Deneke.....206/66  
 2,229,039 1/1941 Brabant.....206/66  
 3,530,978 9/1970 Lewandowski.....206/78 B X  
 3,157,280 11/1964 Perdue et al. ....206/78 B

**FOREIGN PATENTS OR APPLICATIONS**

291,188 5/1928 Great Britain.....206/78

*Primary Examiner*—Leonard Summer  
*Attorney*—Holman & Stern

[30] **Foreign Application Priority Data**  
 Nov. 6, 1968 Great Britain.....52,501/68

[52] **U.S. Cl.**.....206/66  
 [51] **Int. Cl.**.....B65d 85/24  
 [58] **Field of Search**.....206/66, 78 R, 78 B

[57] **ABSTRACT**

A needle package comprising a substantially rigid backing member, a needle mount piece slidably engaged in parallel flanges of the backing member and a transparent panel also engaged in the backing member flanges and overlying the needle mount piece, with sliding movement of the needle mount piece and transparent panel out of the backing member flanges allowing access to be gained to needles between the needle mount piece and the transparent panel.

[56] **References Cited**

**UNITED STATES PATENTS**

3,500,998 3/1970 Sanders .....206/66  
 3,444,995 5/1969 Sanders .....206/66

**1 Claim, 3 Drawing Figures**

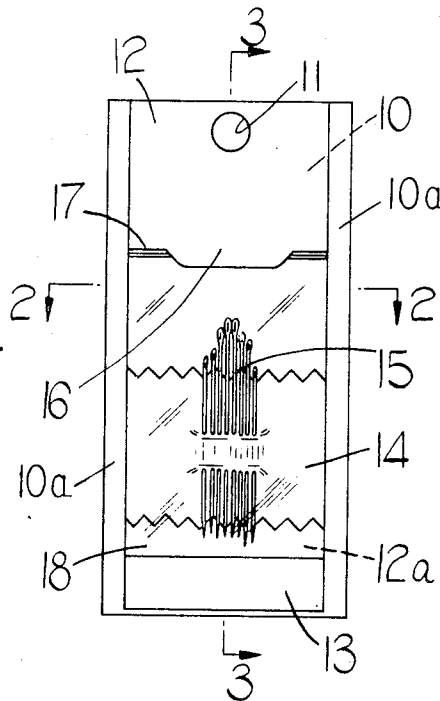

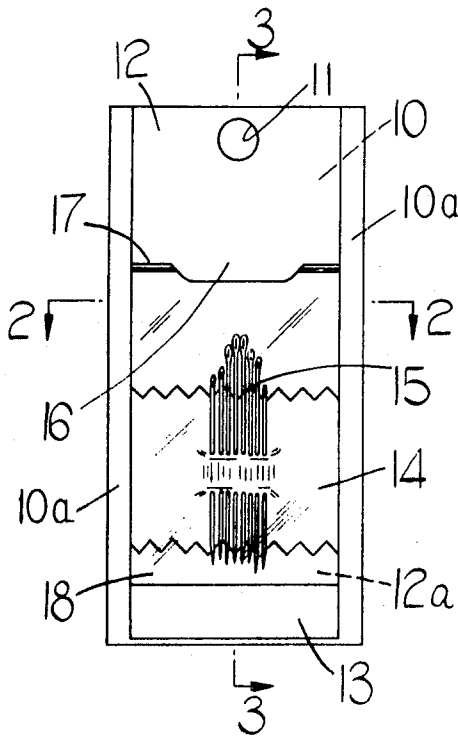

FIG. 1.

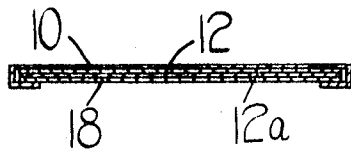

FIG. 2.

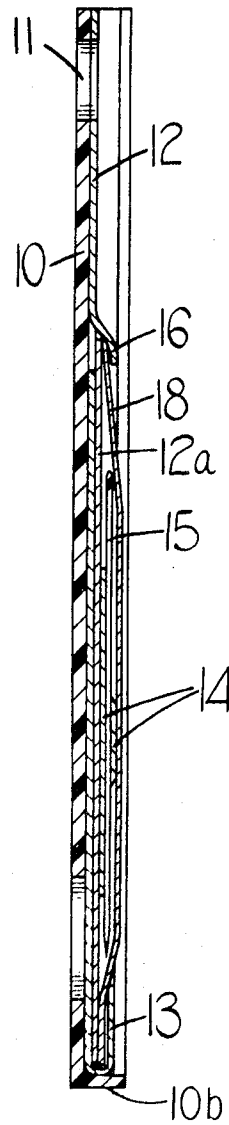

FIG. 3.

INVENTOR  
*Donald Saunders*  
BY *Holman, Blasco*  
*Downing & Bebold*  
ATTORNEYS

## PACKAGE FOR NEEDLES

## BACKGROUND OF THE INVENTION

This invention relates to packages for needles for sewing and like purposes and has for its object to provide such a package which displays the goods and also provides a useful storage container.

## SUMMARY OF THE INVENTION

According to the present invention, a package for needles comprises, in combination, a substantially rigid backing member, provided with retaining flanges on two parallel opposite sides thereof and an end stop at one end of the backing member, a substantially flat needle mount piece, with opposite edges of the mount piece being slidably engaged by the retaining flanges of the backing member, and a transparent panel at the front of the needle mount piece, the transparent panel also overlying an area for needles on the needle mount piece and having opposite edges slidably engaged by the retaining flanges of the backing member, the ends of the transparent panel being engaged by respective flaps formed integrally upon the needle mount piece.

## BRIEF DESCRIPTION OF THE DRAWINGS

The invention will now be described by way of example with reference to the accompanying drawings in which:

FIG. 1 is a front elevation view of a needle package constructed in accordance with the invention,

FIG. 2 is a cross-sectional view on the line 2—2 in FIG. 1, the view looking in the direction of the arrows and

FIG. 3 is an enlarged cross-sectional view on the line 3—3 in FIG. 1, the view looking in the direction of the arrows.

## DETAILED DESCRIPTION OF THE DRAWING

The package comprises a rectangular substantially rigid backing member 10 having integral lipped flanges 10a along its two longer parallel sides and having a further flange 10b along a third side. The backing member is formed as an injection molding from a synthetic resinous material.

Retained by its edges under the flanges of the backing member, is a needle mount piece 12 which is a card. At one end, the card is bent forwards to form a flap 13 as shown in FIG. 3, with the ends of this flap 13 engaging under the side flanges 10a of the backing member. Alternatively, a Z-cross-section may be formed by a double creasing at the end of the card.

Aligned holes 11 in the backing member 10 and needle mount piece 12 are provided for mounting the package on a rack or bar for display.

A further separate portion 12a of the needle mount piece has secured, by adhesive thereacross, a textile strip 14 in which needles 15 are engaged. The portion 12a is a paper strip. Alternatively, the needles can be directly mounted on a paper or card mounting piece or on paper tape, secured to the needle mount piece 12.

Between the strip 14 and the unflanged end of the backing member 10, the needle mount piece 12 is provided with a punched out flap 16. The flap 16 extends beyond a crease line extension across the width of the needle mount piece 12, such crease line being indicated at 17.

Covering the portion 12a of the needle mount piece 12 on which the strip 14 and needles 15 are disposed is a transparent panel 18, having the same shape and size as the portion 12a. The sides of the panel 18 are engaged under the side flanges of the backing member 10, and one of the ends of the panel 18,

as well as the edge of the portion 12a, are engaged under the flap 16 of the needle mount piece, and the other end is engaged under the flap 13 of the needle mount piece.

The transparent panel 18 provides for inspection of the contents of the package. To withdraw, or return a needle, the needle mount piece is slid, together with the strip 14, needles 15 and transparent panel 18, in the direction of the unflanged end of the backing member 10, such movement being lightly resisted by reason of the flap 13 of the needle mount piece. In an alternative construction, travel is limited by integral projections on the side flanges of the backing member adjacent to the unflanged end of the backing member.

Before the needle mount piece 12 is completely withdrawn from the backing member, however, the crease line 17 will pass the end of the backing member and it is thereafter possible to bend the free end portion of the needle mount piece backward, thus releasing the edge of the transparent panel and also the edge of the portion 12a from engagement under the flap 16. Further travel of the needle mount piece out of the backing member will enable the transparent panel 18 to be peeled back in order to gain access to the needles 15.

The package enables ready identification of the contents to be achieved as well as providing a container for permanent storage of the needles.

In an alternative construction, the needle mount piece has a tag of generally T-shape, pressed out of its center portion, with this tag being engaged in a slot in the backing member. The slot extends lengthwise of the backing member and permits limited movement of the needle mount piece in the direction of its length, to permit removal and replacement of needles.

In a further alternative arrangement, the needle mount piece and the transparent panel are secured in the backing member against sliding movement. In this example, securement of these parts is at the end flange of the backing member. The side edges of the transparent panel can be removed from the side flanges for needle removal and these edges are afterwards reinserted into the flanges. The needle mount piece, though secured at its end in the backing member, is, moreover, also free in its mid-region to permit easy removal and replacement of needles.

Having thus described my invention what I claim as new and desire to secure by Letters Patent is:

1. A package for needles comprising, in combination, a substantially rigid backing member provided with retaining flanges on two parallel opposite sides thereof and an end stop at one end of the backing member, a substantially flat needle mount piece, opposite edges of said mount piece being slidably engaged by the retaining flanges of the backing member, and a transparent panel at the front of the needle mount piece, the transparent panel also overlying an area for needles on the needle mount piece and also having opposite edges slidably engaged by the retaining flanges of the backing member, the needle mount piece having respective integral flaps with the ends of the transparent panel being engaged by said flaps to retain the transparent panel in proper position relative to the needle mount piece, one of the flaps being located intermediate the ends of the needle mount piece and overlying one end of the transparent panel beyond a crease extending transversely across the needle mount piece, the crease being so positioned that when the needle mount piece is partially slid out of the backing member, the transparent panel can be disengaged from said one flap by bending the needle mount piece about the crease, to allow access to the needles in the package disposed between the needle mount piece and the transparent panel.

\* \* \* \* \*