

**(12) PATENT**  
**(19) AUSTRALIAN PATENT OFFICE**

**(11) Application No. AU 200016627 B2**  
**(10) Patent No. 766991**

(54) Title  
**Method and rock drilling apparatus for controlling rock drilling**

(51)<sup>7</sup> International Patent Classification(s)  
**E21B 047/022 E21B 044/00**  
**E21B 007/04**

(21) Application No: **200016627**

(22) Application Date: **1999.12.08**

(87) WIPO No: **WO00/34623**

(30) Priority Data

(31) Number	(32) Date	(33) Country
<b>982676</b>	<b>1998.12.10</b>	<b>FI</b>

(43) Publication Date : **2000.06.26**

(43) Publication Journal Date : **2000.08.24**

(44) Accepted Journal Date : **2003.10.30**

(71) Applicant(s)  
**Sandvik Tamrock Oy**

(72) Inventor(s)  
**Unto Ahtola; Arne Lislserud**

(74) Agent/Attorney  
**Griffith Hack,GPO Box 1285K,MELBOURNE VIC 3001**

(56) Related Art  
**WO 93/12318**  
**US 4797822**  
**US 4445578**

16627/00



PCT

WORLD INTELLECTUAL PROPERTY ORGANIZATION  
International Bureau

INTERNATIONAL APPLICATION PUBLISHED UNDER THE PATENT COOPERATION TREATY (PCT)

<p>(51) International Patent Classification <sup>7</sup> : E21B 47/022, 44/00, 7/04</p>	<p>A1</p>	<p>(11) International Publication Number: <b>WO 00/34623</b> (43) International Publication Date: 15 June 2000 (15.06.00)</p>
<p>(21) International Application Number: PCT/FI99/01020 (22) International Filing Date: 8 December 1999 (08.12.99) (30) Priority Data: 982676 10 December 1998 (10.12.98) FI (71) Applicant (for all designated States except US): SANDVIK TAMROCK OY [FI/FI]; Pihtisulunkatu 9, FIN-33330 Tampere (FI). (72) Inventors; and (75) Inventors/Applicants (for US only): AHTOLA, Unto [FI/FI]; Mäkikatu 51, FIN-33250 Tampere (FI). LISLERUD, Arne [FI/FI]; Agronominkuja 7-B 2, FIN-33820 Tampere (FI). (74) Agent: KOLSTER OY AB; Iso Roobertinkatu 23, P.O. Box 148, FIN-00121 Helsinki (FI).</p>	<p>(81) Designated States: AE, AL, AM, AT, AT (Utility model), AU, AZ, BA, BB, BG, BR, BY, CA, CH, CN, CR, CU, CZ, CZ (Utility model), DE, DE (Utility model), DK, DK (Utility model), DM, EE, EE (Utility model), ES, FI, FI (Utility model), GB, GD, GE, GH, GM, HR, HU, ID, IL, IN, IS, JP, KE, KG, KP, KR, KZ, LC, LK, LR, LS, LT, LU, LV, MA, MD, MG, MK, MN, MW, MX, NO, NZ, PL, PT, RO, RU, SD, SE, SG, SI, SK, SK (Utility model), SL, TJ, TM, TR, TT, TZ, UA, UG, US, UZ, VN, YU, ZA, ZW, ARIPO patent (GH, GM, KE, LS, MW, SD, SL, SZ, TZ, UG, ZW), Eurasian patent (AM, AZ, BY, KG, KZ, MD, RU, TJ, TM), European patent (AT, BE, CH, CY, DE, DK, ES, FI, FR, GB, GR, IE, IT, LU, MC, NL, PT, SE), OAPI patent (BF, BJ, CF, CG, CI, CM, GA, GN, GW, ML, MR, NE, SN, TD, TG).</p> <p>Published With international search report.</p>	

(54) Title: METHOD AND ROCK DRILLING APPARATUS FOR CONTROLLING ROCK DRILLING

(57) Abstract

A method and a rock drilling apparatus for drilling holes in rock according to a predetermined drilling plan. The method comprises measuring the location of each hole in the rock by inserting a measuring device (11) into the hole, and calculating the deviation of the end of the measured hole from the location determined in the drilling plan. The rock drilling apparatus comprises a measuring device that can be inserted into a drill hole, and means for transferring the measurement values measured by the measuring device to control means of the rock drilling apparatus.

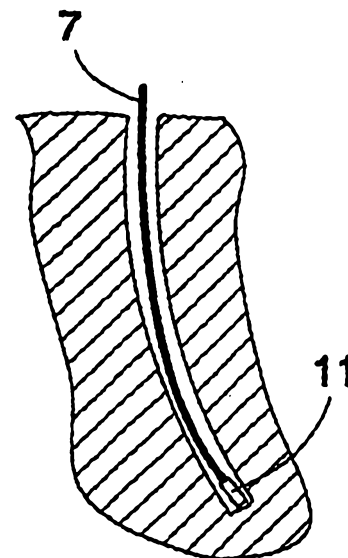

## METHOD AND ROCK DRILLING APPARATUS FOR CONTROLLING ROCK DRILLING

The invention relates to a method for controlling rock drilling, in  
5 which method holes are drilled in rock according to a predetermined drilling  
plan, which determines the length and position of each hole with respect to the  
other holes in the rock to be drilled in a three-dimensional coordinate system.

The invention also relates to a rock drilling apparatus for drilling  
holes in rock according to a predetermined drilling plan, the apparatus  
10 comprising drilling means for drilling holes in rock, and control means for  
positioning the drilling means at each hole to be drilled and correspondingly for  
drilling a hole automatically according to said drilling plan.

It is previously known to use different types of measuring devices  
for measuring the deviation of a drill hole. The operation of such measuring  
15 devices is usually based on a compass, gravitation, inertia or any combination  
thereof. This type of measuring devices have been used especially in oil  
drilling technology for checking the direction of a drill hole and also for locating  
a hole. A problem with these measuring devices has been that the  
measurement is slow and the devices are large. Therefore, it has not been  
20 possible to use measurement of drill hole deviation or the measurement data  
for controlling drilling in ground excavation during rock drilling, nor for  
controlling the charging occurring after the drilling. When holes are drilled in  
rock especially during the excavation of tunnels or blasting of the material to  
be excavated, the accuracy of the drilling has become more and more  
25 important. Especially when drilling long holes, it is rather common that a hole  
becomes curved and the actual end of the hole is located rather far from the  
intended end position. Accordingly, the breakage of material, the orientation of  
a tunnel and other factors take place uneconomically and they may cause  
additional work and costs.

30 What is essential for the final result of the blasting is that the  
deviation of the drill hole and especially the location of the ends of the holes  
and therefore the relation of the hole ends with respect to one another must be  
known as accurately as possible in order that the blasting could be  
implemented in a desired manner. The purpose of the present invention is to  
35 provide a method and an apparatus which enable effective, accurate and rapid

implementation of measurements and which also make it possible to change a predrafted drilling plan during the drilling, if required.

5 According to the present invention, there is provided a method for controlling rock drilling, in which at least two holes are drilled into rock according to a predetermined drilling plan, which determines the length and position of each hole with respect to the other holes in the rock to be drilled in a three-dimension coordinate system, the method comprising:

- 10 • measuring the actual location of the end of at least one predetermined drill hole in the rock by inserting or lowering into the drill hole a measuring device, which indicates the current location of the drill hole with respect to the rock in the three-dimensional coordinate system;
- 15 • calculating the deviation of the end of the measured hole from the location of the end of the drill hole determined in the drilling plan; and
- 20 • changing the drilling plan according to the calculated deviation.

25 According to another aspect of the present invention, there is provided a rock drilling apparatus for drilling holes in rock according to a predetermined drilling plan, the apparatus comprising:

- 30 • a drilling means for drilling holes in rock;
- a control means for positioning the drilling means at each hole to be drilled and correspondingly for drilling a hole automatically according to said drilling plan;
- a measuring device that can be inserted or lowered into a drill hole;
- a feeding means for inserting or lowering the measuring device into the drill hole and for pulling the measuring device out of the hole; and
- 35 • a transferring means for transferring the measurement values measured by the measuring device to the

control means.

The basic idea of the invention is that a measuring device is inserted into a drill hole in order to measure at least the location of the hole end with respect to the rock in a three-dimensional coordinate system so as to determine the position of the hole end compared to the original drilling plan and thus with respect to the other holes.

Another basic idea of the invention is that the measurement result of the measuring device can be used, if required, to change the drilling plan of one or several successive holes or even to drill extra holes. A preferred embodiment of the invention comprises a separate feeding device with which an inertia measuring device is inserted into a drill hole directly after the drilling so that a measurement result is obtained immediately before the drilling apparatus is moved to the drilling point of the next hole, and required changes can be made before the drilling is started. According to another preferred embodiment of the invention, the measuring device is placed at the end of a feed hose that does not bend while it is pushed, so that the measuring device can be inserted into the hole and pulled out of it easily by using suitable mechanical feeding means for feeding the hose into the hole and for pulling it therefrom. According to a third preferred embodiment of the invention, the measuring device is fed into the hole simultaneously with the drill bit and the measurement is thus carried out simultaneously with the drilling. According to a fourth preferred embodiment of the invention, the measuring device is an

inertia measuring device, which is inserted into the drill hole at such a speed that a reliable measurement result is obtained. Thus, if the initial point of the drill hole is known, it is possible to measure reliably the location of the hole end and, if required, the shape and direction of the hole continuously along the entire length of the hole.

The invention has an advantage that it enables measuring, simply and rapidly, the final location of the end of a drilled hole and also the shape and position of the entire hole. If required, it is thus possible to change the drilling plan so that the holes can be located suitably with respect to one other for the blasting. Depending on the application, the end of the drill hole may refer to only the final end of the hole or to a predetermined length of the hole from the hole end towards the beginning thereof. The invention is easy to implement and automate, so that the operator does not have to make any special calculations, but an automatic control system attends to the operation of the apparatus automatically.

The invention will be described in greater detail in the accompanying drawings, in which

Figure 1 shows schematically a rock drilling apparatus,

Figures 2a to 2c show schematically implementation of the method according to the invention in measuring a hole,

Figure 3 shows schematically application of the method according to the invention for changing a drilling plan, and

Figures 4a and 4b shows schematically a positioning device for positioning a drill bit and a measuring device at a drill hole.

Figure 1 shows schematically a rock drilling apparatus intended for drilling a hole in rock. The rock drilling apparatus comprises a carrier 1 to which a boom 2 is connected in a manner known per se, the boom being preferably turnable with respect to the carrier 1 in different positions in a known manner. The end of the boom 2 away from the carrier is provided with a drilling device in a manner known per se. The drilling devices are known per se, wherefore they will be described generally below. At the end of the boom 2 there is a feeding beam 3 of the rock drilling apparatus, connected to the boom either directly or via a separate cradle structure or the like that is known per se. A rock drilling machine 4 moves along the feeding beam during the drilling. The rock drilling machine 4 is in turn connected to a drill rod 5, the end of which is provided with a drill bit 6. When longer holes are drilled, the drill rod

5 usually consists of extension rods that are connected together in order to drill a hole that is longer than the mere feeding length of the feeding device. The figure further shows a reel 8 of a device 7 for feeding the measuring device, and control means 9 for controlling the flexible feeding device, which is preferably a feed hose that can be pushed without bending.

When such an apparatus is used to drill holes in rock, both excavation of a tunnel and ore extraction and rock excavation employ predrafted drilling patterns that determine the holes required for blasting and the location of the holes with respect to each other in the rock. Also, especially in tunnel excavation it is sometimes necessary to drill grout holes around the projected tunnel profile before the excavation, so that cement or some other sealing material can be pumped into the holes to prevent leakages. The grout holes are also drilled according to a predetermined drilling plan or drilling pattern, which determines the holes and the positions thereof with respect to one another.

This can be carried out mathematically in different ways, which often include determining the initial points of the holes as well as their direction and distance from a certain plane, or the location of the end of a hole with respect to the rock in a three-dimensional coordinate system. Presently, the drilling is often carried out automatically, which means that the control means of the drilling apparatus comprise a computer where the drilling plan is stored. Thus, the position of the drilling apparatus with respect to the rock is defined such that the computer can automatically implement the drilling of the holes in a suitable order on the basis of the drilling plan.

Figures 2a to 2c show schematically an implementation of the method according to the invention in drilling holes in rock. Figure 2a shows schematically how the drill rod 5 and the drill bit propagate in the rock, producing a slightly curved hole 10. In Figure 2b, the drill rod and the drill bit have been pulled out of the hole and the feed hose 7 is in turn placed at the beginning of the hole, the tip of the hose being provided with a measuring device, preferably an inertia measuring device 11. This measuring device may operate according to any useful principle, in other words its operation may be based on a magnetic field, gravitation, inertia or any combination thereof.

Figure 2c shows how the measuring device 11 is inserted into the hole 10 at a suitable speed, so that as the device moves it stores its location defined in a certain manner in the three-dimensional coordinate system, where

the drilling plan is also determined with respect to the rock. The measuring device 11 can be arranged, for example, to store its location at predetermined intervals, for instance at intervals of 1 to 2 seconds. Accordingly, when the feed hose 7 is inserted at a constant speed, the position of the inertia measuring device is obtained as a function of the length of the drill hole 10 from the beginning of the hole. When the location of the measuring device at the beginning of the hole is known, it is possible to measure the shape of the hole and to correspondingly determine the position of the hole with respect to the rock in the three-dimensional coordinate system and thus with respect to the drilling pattern. The measuring device can also be arranged to input data about its location non-stop, which results in a signal that continuously indicates the shape of the curve. In this embodiment, the measuring device can be used for example in such a way that it operates with its own power source and stores the readings in its memory while it is inserted into the hole. In such a case, the data stored in the memory must be transferred to the control unit of the rock drilling apparatus for example via a radio path or in some other manner, preferably by a wireless communication system. Alternatively, the measuring device can be connected directly to the control unit of the rock drilling apparatus by a cable passing through the feed hose, so that the measurement values provided by the device are transmitted directly to the control unit, which may continuously monitor and change the drilling plan of the next drill hole(s), if required. The measuring device can also be fed all the way to the drill bit via a drilling pipe.

The inertia measuring device used according to a preferred embodiment of the invention is known per se. When the device is employed in the three-dimensional coordinate system, it is based on three gyroscopic discs placed perpendicularly with respect to one other and rotating around an axis. The discs are used to accurately measure the acceleration and speed of motion of the measuring device in different directions. The essential feature of the measurement is that the speed of motion from the starting point is sufficiently fast in the drill hole during the measurement, so that changes can be measured accurately enough. Such devices are commercially widely available and they are generally known, wherefore they will not be described in greater detail herein.

Figure 3 shows schematically how the drilling plan can be changed by means of the measuring method and device according to the invention. The



figure shows with solid lines a preliminary drilling plan which includes holes 12a to 12f that are to be drilled on the same plane, one solid line corresponding to one planned hole. Figure 3 further shows with thick broken lines 13a to 13c the holes that have actually been drilled, whereas thin broken lines 12d' and 12e' show the places of the new holes according to the drilling plan changed in accordance with the measurement of the drilled holes.

As shown in the figure, the drilled holes 13b and 13c are curved and their ends are situated rather close to one another. Correspondingly, in order that it would not be necessary to drill more holes than designed in the plan, the direction of the rest of the holes has been changed in the drilling plan so that the holes are positioned more evenly in the area of the remaining rock without great distances between any two holes. The drilling plan was changed when the measuring device 11 had measured the shape of the last hole 13c and its position in the rock. In practice, the drilling plan does not have to be changed due to small deviations if the rest of the holes remain in place accurately enough. Alternatively, it would have been possible to keep the holes 12d to 12f in their old places according to the plan, and an extra hole denoted by a dot-and-dash line 12' could have been added between the drilled hole 13c and the planned hole 12d. Further, the data about the deviation of the holes can also be used to optimize the charging plan, for example by adjusting the density of charge in relation to the actual distances between the holes. Therefore, the amount of blasting agent required for different holes and even the placement of specific charges can be calculated separately on the basis of the shapes of the measured holes and/or the position of the hole ends.

However, by measuring changes in the direction of the hole or the curvature of the hole along its length, it is also possible to predict to some extent the curvature and direction of the next holes and to take it into account in determining a new location for the holes in the drilling plan.

Figures 4a and 4b, in turn, show schematically how the rock drilling apparatus and the inertia measuring device can be placed at the beginning of a hole. In this arrangement known per se in rock bolting apparatuses, the feeding beam and correspondingly the control means 9 of the feed hose 7 are connected to the same frame 14, which is in turn connected to be turned around a longitudinal axis 15 of the feeding beam 3 by a separate actuator 16. When the actuator has turned the feeding beam 3 counter-clockwise as shown

in Figure 4a, the drill rod and the drill bit of the rock drilling apparatus are positioned at the hole to be drilled. Correspondingly, when the actuator turns the feeding beam and the control means clockwise, the control means and thus the end of the feed hose are positioned at the beginning of the hole. As shown in Figure 4b, the feed hose of the measuring device can be positioned at a drilled hole in several manners known per se, but this arrangement is rather simple and easy to implement.

The invention is described above by way of an example shown in the drawings, and it is not restricted thereto in any way. The invention can be applied in both vertical and horizontal rock drilling and also upwards and downwards. In order for a measurement to be carried out substantially at a constant speed, and the location of the measurement points to be determined accurately in the longitudinal direction of a hole, it is necessary to use a pushing device, such as a rather stiff and still flexible feed hose or the like, comprising at its end the measuring device. The measuring device can thus be pushed to the end of the hole reliably and the measurement results can be used for determining both the shape of the drilled holes and the location of the hole end, as well as for changing the drilling plan, if required. It is essential that measurement takes place automatically whenever needed, and that the measurement results are transferred to the control unit, such as a computer, comprised in the control means of the rock drilling apparatus to be used directly, so that the drilling plan is changed before the drilling on the basis of the measurement results.

In the claims which follow and in the preceding description of the invention, except where the context requires otherwise due to express language or necessary implication, the word "comprise" or variations such as "comprises" or "comprising" is used in an inclusive sense, i.e. to specify the presence of the stated features but not to preclude the presence or addition of further features in various embodiments of the invention.

THE CLAIMS DEFINING THE INVENTION ARE AS FOLLOWS:

1. A method for controlling rock drilling, in which at least two holes are drilled into rock according to a predetermined drilling plan, which determines the length and position of each hole with respect to the other holes in the rock to be drilled in a three-dimension coordinate system, the method comprising:

• measuring the actual location of the end of at least one predetermined drill hole in the rock by inserting or lowering into the drill hole a measuring device, which indicates the current location of the drill hole with respect to the rock in the three-dimensional coordinate system;

• calculating the deviation of the end of the measured drill hole from the location of the end of the drill hole determined in the drilling plan; and

• changing the drilling plan according to the calculated deviation.

2. A method according to claim 1, in which the position of non-drilled holes in the drilling plan are changed before drilling actual holes for the non-drilled holes.

3. A method according to claim 1 or 2, in which a required number of new holes are added to the drilling plan.

4. A method according to any one of claims 1 to 3, in which each drilled hole is measured, and the drilling plan is changed after the measurement of each hole, if required.

5. A method according to any one of claims 1 to 4, in which the deviation of a hole is measured at predetermined intervals along the entire length of the

hole.

6. A method according to any one of claims 1 to 4, in which the deviation of a hole is measured substantially continuously.

7. A method according to any one of the preceding claims, in which the measurement is carried out substantially immediately after the hole has been drilled.

8. A method according to claim 7, in which a measuring device is inserted into the drill hole and pulled out of the drill hole by means of a flexible elongated pushing device.

9. A method according to claim 8, in which the flexible elongated pushing device is a hose.

10. A method according to any one of claims 1 to 7, in which the measurement is carried out during the drilling.

11. A method according to any one of the preceding claims, in which the rock drilling apparatus includes a control means which is arranged to be in continuous contact with the measuring device, and that measurement values of the measuring device are transferred substantially continuously to the control means of the rock drilling apparatus during the measurement.

12. A method according to any one of claims 1 to 10, in which measurement values of the measuring device are stored in a memory of the device during the measurement and transferred to the control means of the rock drilling apparatus after the measuring device has been pulled out of the drill hole.

13. A method according to any one of the preceding

claims, in which the measuring device is an inertia measuring device.

5 14. A method according to any one of the preceding claims, in which the amount and position of the blasting agent used in blasting is determined for each hole on the basis of the measurement of the holes.

10 15. A rock drilling apparatus for drilling holes in rock according to a predetermined drilling plan, the apparatus comprising:

- a drilling means for drilling holes in rock;
- a control means for positioning the drilling means at each hole to be drilled and correspondingly for  
15 drilling a hole automatically according to said drilling plan;
- a measuring device that can be inserted or lowered into a drill hole;
- a feeding means for inserting or lowering the  
20 measuring device into the drill hole and for pulling the measuring device out of the hole; and
- a transferring means for transferring the measurement values measured by the measuring device to the control means.

25 16. A rock drilling apparatus according to claim 15, in which the feeding means for feeding the measuring device into the drill hole comprises an elongated flexible device at the beginning of which the measuring device is  
30 positioned, a reel for storing the flexible device, feeding means for inserting the flexible device into the drill hole, and positioning means for positioning the drilling means and the flexible device for drilling and correspondingly for measurement at the drill hole.

35 17. A rock drilling apparatus according to claim 16, in which the flexible device is a hose.

18. A rock drilling apparatus according to claim 17, in which the transferring means for transferring the measurement values comprise a cable which is passed inside the hose and with which the measuring device is connected to the control means.

19. A rock drilling apparatus according to any one of claims 15 to 17, which further comprises a transferring means for transferring the memory data stored in the memory of the measuring device to the control means wirelessly.

20. A rock drilling apparatus according to any one of claims 15 to 19, in which the measuring device is an inertia measuring device.

21. A method for controlling rock drilling, substantially as hereinbefore described with reference to the accompanying drawings.

22. A rock drilling apparatus, substantially as hereinbefore described with reference to the accompanying drawings.

Dated this 27th day of August 2003

SANDVIK TAMROCK OY

By their Patent Attorneys

30 GRIFFITH HACK

Fellows Institute of Patent and  
Trade Mark Attorneys of Australia

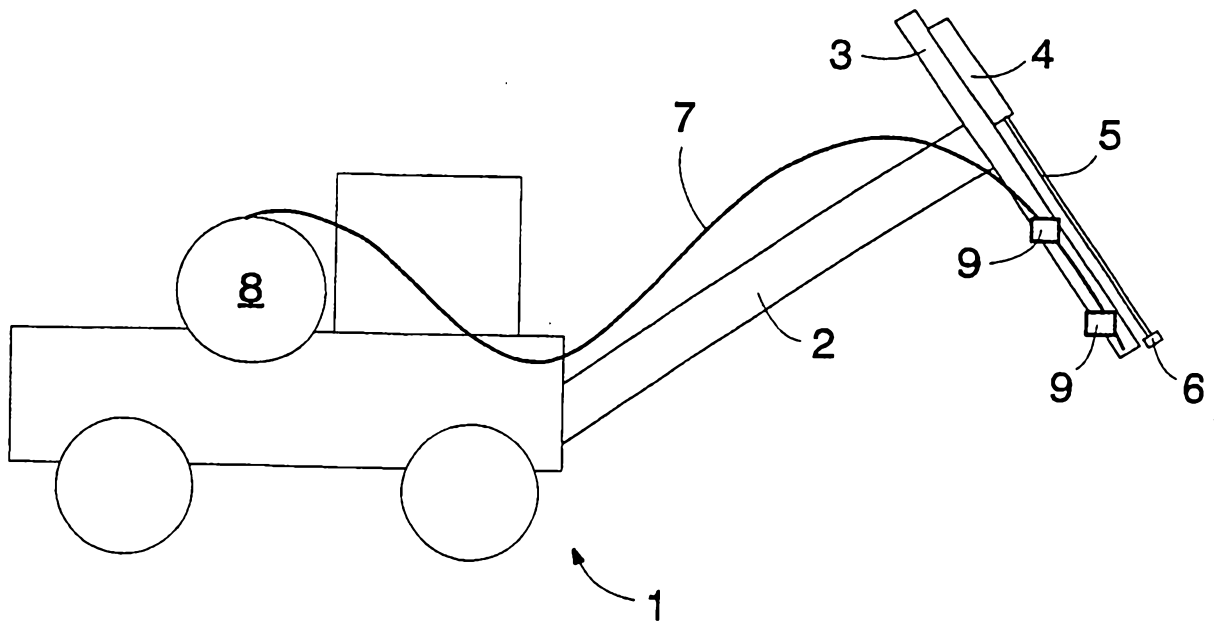

FIG. 1

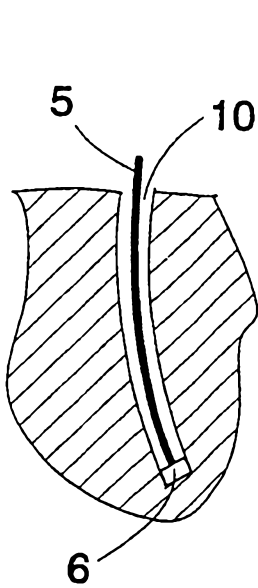

FIG. 2a

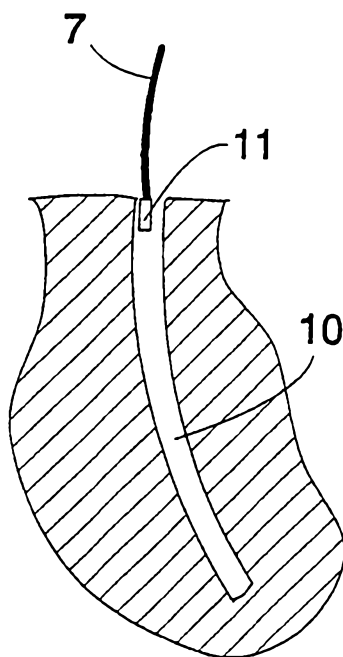

FIG. 2b

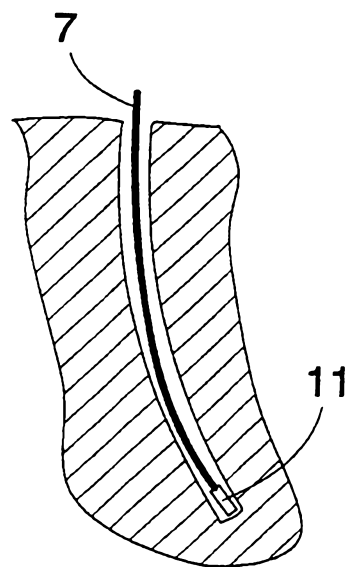

FIG. 2c

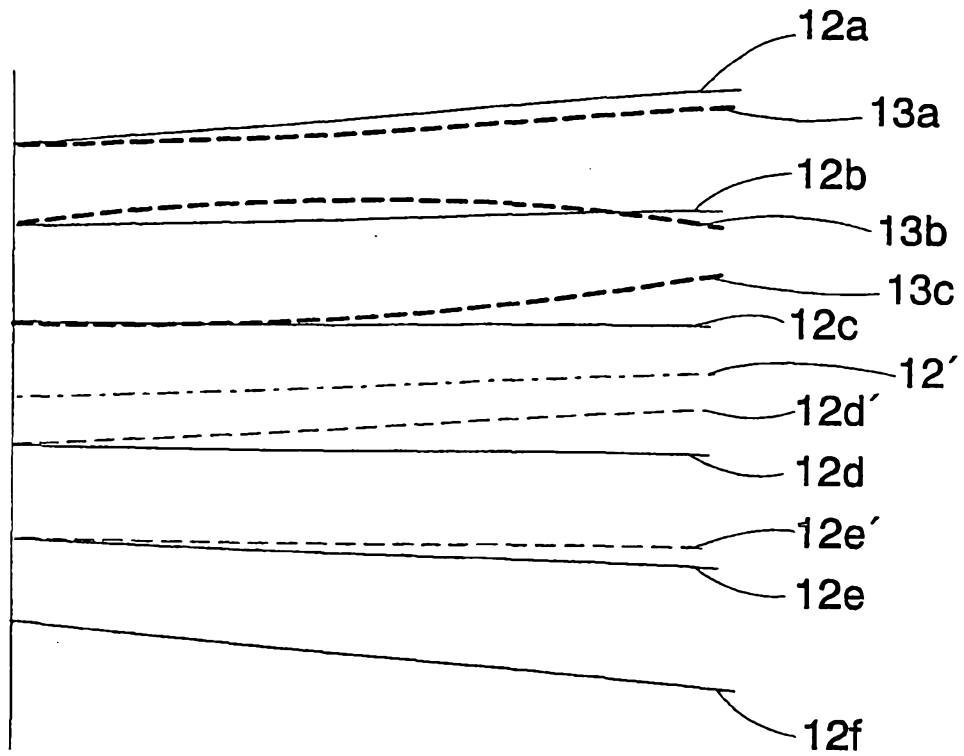

FIG. 3

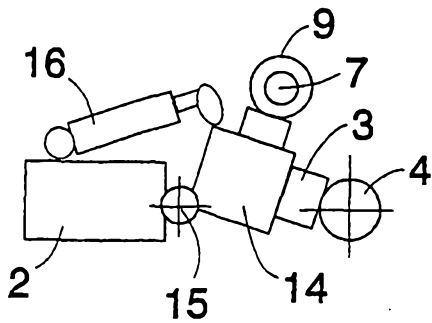

FIG. 4a

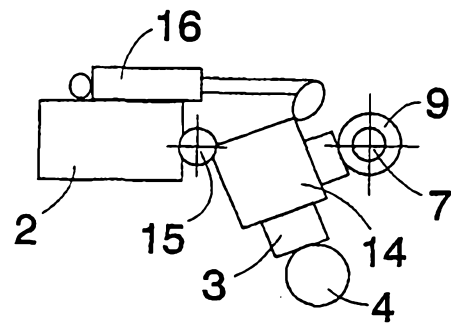

FIG. 4b