

[72] Inventors **Norval W. Postweiler**
Maplewood, N.J.;
George Vrana, Flushing, N.Y.

[21] Appl. No. **763,788**

[22] Filed **Sept. 30, 1968**

[45] Patented **Feb. 9, 1971**

[73] Assignee **Riegel Paper Corporation**
New York, N.Y.
a corporation of Delaware

[56] **References Cited**

UNITED STATES PATENTS

2,608,341	8/1952	Eckman	229/51(IS)
2,706,076	4/1955	Guyer	229/51(IS)
2,886,231	5/1959	Benzon-Petersen.....	229/37X
2,930,518	3/1960	Cottrill	229/51(IS)
3,056,665	10/1962	Linda et al.....	(229/51IS)
3,232,513	2/1966	Maio	229/14C
3,291,372	12/1966	Saidel.....	229/51RC

Primary Examiner—David M. Bockenek
Attorney—Mandeville and Schweitzer

[54] **COMPOSITE LEAKPROOF CARTON**
1 Claim, 5 Drawing Figs.

[52] U.S. Cl..... **229/51,**
 229/14, 229/37

[51] Int. Cl..... **B65d 5/54,**
 B65d 5/70

[50] Field of Search..... 229/51ISL,
 51RC, 14BI, 14BW, 37

ABSTRACT: The disclosure relates to a composite leakproof carton construction having a parallelepiped outer shell, a full length tubular liner tightly fitted within the outer shell, and sealing membranes adhered to outfolded carton end flaps of the shell and gasketed between the liner end edges and said flaps when the flaps are infolded. The carton is easily openable by a shell encircling tear strip, the removal of which forms a telescopicly reclosable cover or cap member.

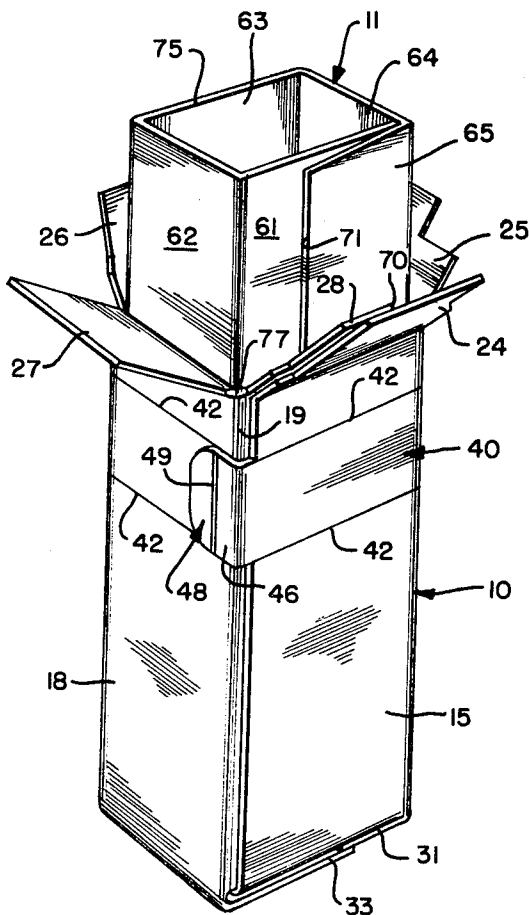

FIG. 1

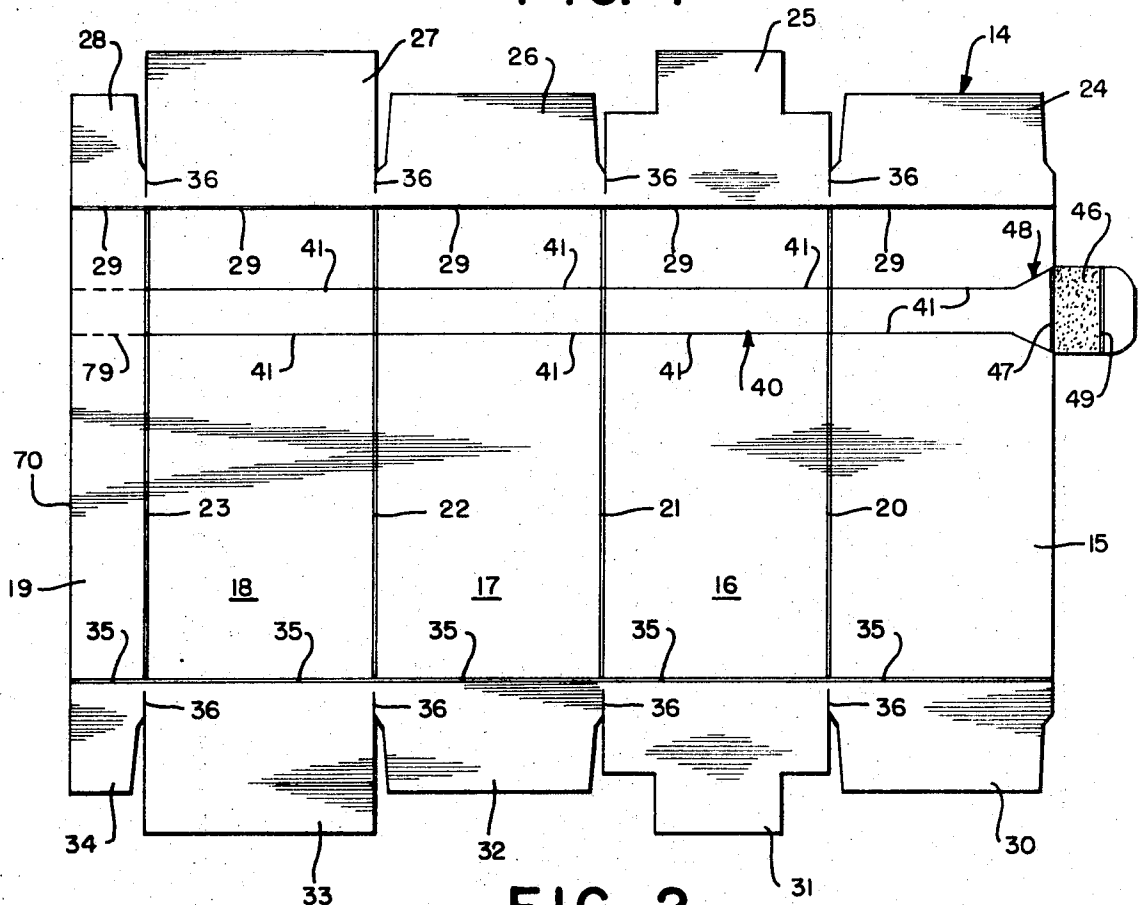
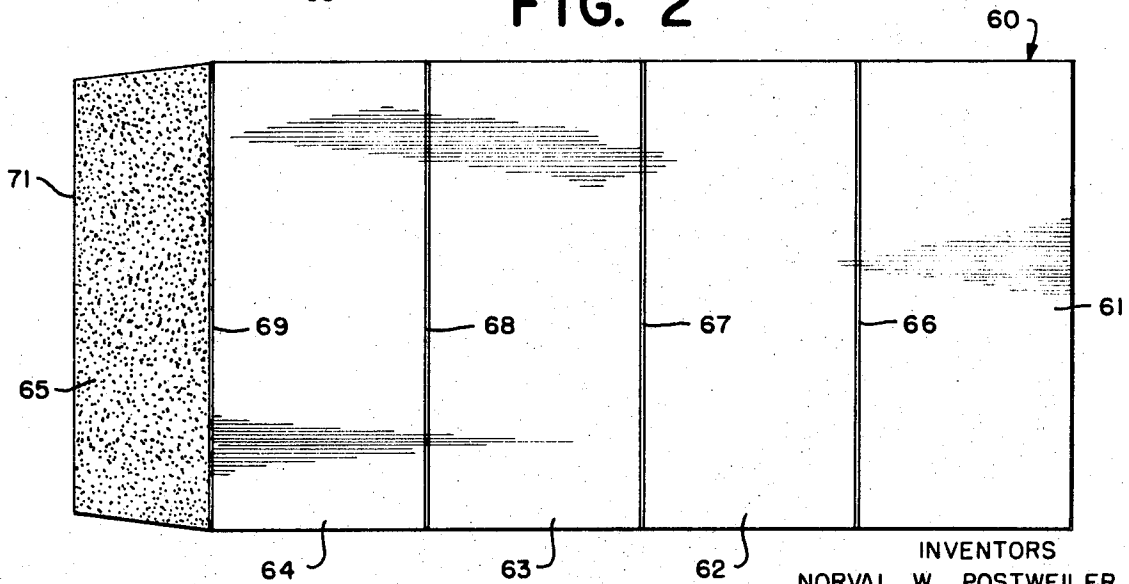

FIG. 2



INVENTORS
NORVAL W. POSTWEILER
GEORGE VRANA

BY *Mandeville & Schweitzer*

ATTORNEYS

FIG. 5

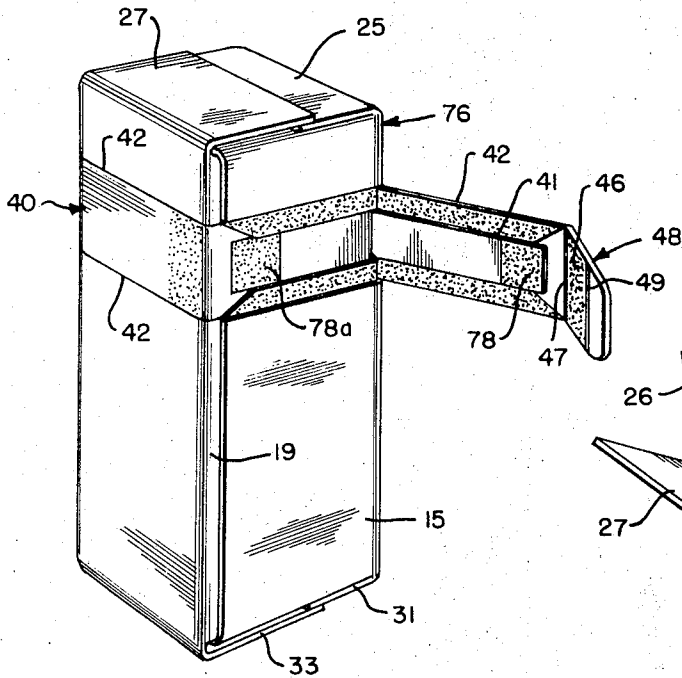

FIG. 3

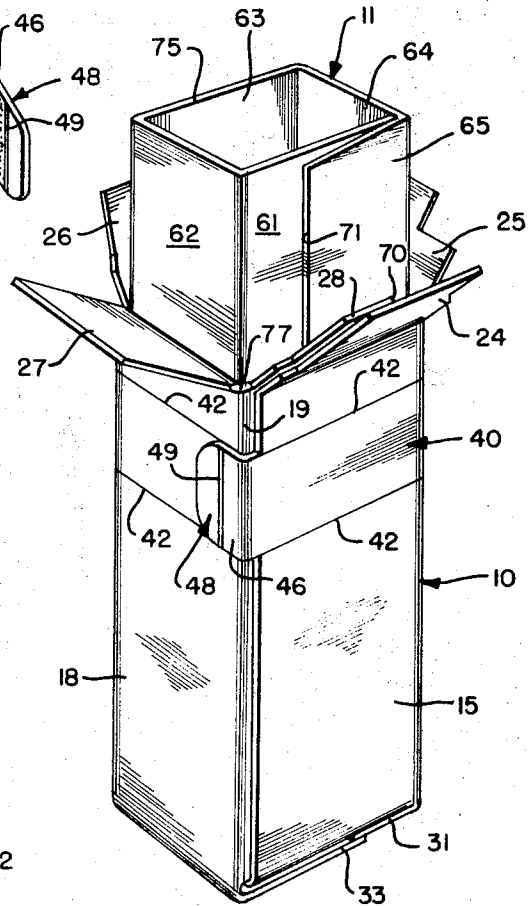
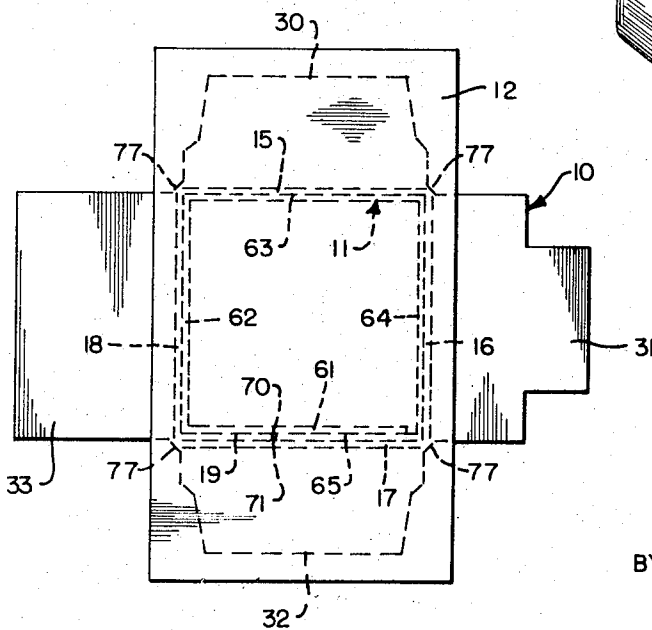

FIG. 4



INVENTORS
NORVAL W. POSTWEILER
GEORGE VRANA

BY *Mandeville & Schweitzer*

ATTORNEYS

COMPOSITE LEAKPROOF CARTON

SUMMARY OF INVENTION

The present invention relates to a new and improved composite carton having exceptional packaging properties especially adapting the carton for leakproof and siftproof use with all types of liquid or pulverulent materials. Specifically, the carton of the invention is in the shape of a parallelepiped and comprises four separate elements, an outer carton shell, an inner open ended liner, and two internal end sealing membranes. The outer shell includes four contiguous side walls and internal glue flap conventionally arranged to define a rectangular tube. Additionally, the shell has end flaps articulated to the opposite ends of each sidewall. These flaps are out turned into the end planes of the carton so that the inner surfaces thereof may be used to anchor end-sealing membranes of suitable, flexible web material, such as polyethylene coated paper or glassine. Advantageously and in accordance with the teachings of U.S. Pat. No. 2,795,364, the end corner junctions of the shell may be provided with tufts of free fibrous strands to enhance corner sealing and anchoring of the membrane to the flaps.

In accordance with the principles of the invention, the carton includes a closely fitting tubular liner fabricated from a paperboard material, laminated or otherwise, having predetermined properties (strength, WVTR, etc.) which, in combination with the outer carton sidewalls, will especially adapt the paperboard carton of the invention for packaging requirements, including extended shelf life, which heretofore were satisfied exclusively by cans, bottles, and tubes manufactured from glass, metal, and plastic. The length of the liner walls is chosen so that the membrane material is effectively "gasketed" between the end edges of the liner and the undersides of the finally infolded end flaps of the shell.

Thus, the carton of the invention has a multiplex side wall construction defined by outer shell walls and closely fitting inner liner walls and a multiplex end wall construction defined by the plural end flaps and the sealing membranes.

More specifically and in accordance with the invention, the manufacturer's joint of the liner is arranged to mate tightly with the manufacturer's joint of the outer carton walls in a nested relation to enhance the overall tightness and the overall rigidity of the completed composite package. This arrangement, in which the free or raw edge of the outer carton glue flap and the free or raw edge of the liner are in substantial abutment, will tend to eliminate any edge wicking of the packaged contents, as will be understood.

As a further important aspect of the invention, a tear opening strip of the nonleaking type generally disclosed in U.S. Pat. No. 2,608,341, are arranged in the carton sidewalls in a manner whereby its removal easily opens the carton without destruction of the sealing membranes while forming a reclosable telescoping cover or end cap.

As will be appreciated, the new carton construction provides a packager of fluid or pulverulent materials with enormous flexibility. For example, a supply of "standard" inexpensive outer shells manufactured from lightweight and comparatively inexpensive paperboard may be selectively combined with liners of any construction ranging from simple vat lined board to complex laminates and with end sealing membranes ranging from light to heavy gauge plastic films, thermoplastic coated glassines, or thermoplastic coated papers or laminates to meet a specific application. In this manner, "standard" shells having an overall configuration adapted to be run on existing special packaging machinery may be employed to package products ranging from comestibles, such as frozen fruit juices and powdered milk to industrial products such as lubricants and the like.

DESCRIPTION OF THE DRAWINGS

For a more complete appreciation of the invention and its attendant advantages, reference should be made to the following detailed description taken in conjunction with the accompanying drawings, in which:

FIGS. 1 and 2 are plan elevational views of the outer shell and liner, respectively, for a composite package embodying the inventive principles;

FIG. 3 is a perspective view of the package of the invention during the final steps of manufacture;

FIG. 4 is an end elevational view of the carton of the invention; and

FIG. 5 is a perspective view of the completed composite package with the tear strip partially removed.

DESCRIPTION OF PREFERRED EMBODIMENT

As mentioned hereinabove, the new and improved leakproof carton of the invention generally includes an outer carton shell 10, an inner liner 11, and end sealing membrane 12 (see FIGS. 3 and 4).

Specifically, and as shown best in FIG. 1, the outer shell 10 is fabricated from a paperboard blank 14 which includes contiguous side wall panels 15-18 and a glue flap panel 19 consecutively articulated by parallel vertical score lines 20-23, respectively. Upper end flaps 24-28 are articulated to the upper edges of the panels 15-19, respectively, along a continuous longitudinal score line 29. In a similar manner, bottom end flaps 30-34 are articulated to the lower edges of the panels 15-19, respectively, along a continuous score line 35 which is parallel to the score line 29. Advantageously, the aforementioned end flaps 24-28 and 30-34 are separated from each other by cuts 36 which terminate short of the parallel score lines 29, 35, in accordance with the teachings of the aforementioned U.S. Pat. No. 2,795,364, for purposes to be described in greater detail hereinafter. The particular configurations of the end flaps, which may be designed for heat seal, interlocking, or glue closure, form no part of the present invention and need not be considered further.

In accordance with a specific aspect of the invention, a blank dividing tear strip 40 extends across the blank 14 and is cooperatively defined by a pair of closely spaced parallel cuts 41 which are impressed approximately half way through the inner surface (in terms of the erected carton) of the board and a pair of widely spaced cuts 42 (see FIG. 3) which are impressed approximately half way through the outer side of the carton blank in parallel and straddling relation with the cuts 41. As shown in FIG. 1, the cuts 41 diverge immediately adjacent the outer edge of the wall panel 15 at which area a tongue portion 46 is articulated thereto along score line 47. The tongue portion 46 and divergent portions of the strip 42 form a starting tab 48. Advantageously, the starting tab 48 also includes a score line 49 parallel to the score line 47 to facilitate opening of the completed composite package, as will be described in greater detail hereinafter.

Referring now to FIG. 2, the liner member 11 is formed from a blank 60 which includes contiguous sidewall panels 61-64 and a glue flap panel 65 which are consecutively articulated along parallel vertical score lines 66-69. In accordance with the principles of the invention, the width and height of each of the panels 61-64 are chosen in order to fit the liner snugly within the outer shell 10. Therefore, the dimensions of the panels 61-64 are substantially identical to the dimensions of the shell sidewalls 15-18. Moreover, in accordance with the invention, the raw edges 70, 71 of the glue flap panels 19, 65, respectively, are adapted to meet in abutting relationship in the erected form of the new composite carton. Accordingly, the combined widths of the glue flap panels 19, 65 are substantially equal to the widths of the shell sidewall 15, as will be understood.

The new and improved composite package of the invention may be erected on readily available packaging machinery of the so-called "Expresso" type commercially available from the Bartelt Engineering Company Inc. Rockford, Illinois. The sequence of package formation is generally as follows: Collapsed outer shell carton tubes are formed by infolding the blank 14 initially about the score line 22 and then folding the remaining portions about the score line 20. Thereafter, the glue flap 19 is adhered to the sidewall panel 15. Subsequently,

the collapsed carton tube is squared and the bottom flaps are outfolded, as shown generally in FIG. 4. This operation forms tufts 77 of fibrous material at each of the carton shell corners by tearing of the paperboard beyond the termination of the cuts 36. As discussed in greater detail in the U.S. Pat. No. 2,886,231, these tufts enhance sealing of the end of the carton with a flexible membrane 12. The membrane 12, which may be suitably coated glassine, polyethylene or other flexible sheet material, is appropriately sized to cover the entire end opening of the carton, as shown in FIG. 4, and is adhered by conventional techniques such as heat sealing, gluing, or the like to the underlying portions of the flaps 31-34. Thereafter, the bottom end of the new package is completed by consecutively infolding the flaps 30, 32; the flap 31; and the flap 33.

The next step in the completion of the package of the invention is the insertion of the liner 11 in the shell 10. The liner may be first formed as a collapsed tube by infolding the panel 61 about the score line 66 and then infolding the panels 64, 65 about the panel 68 before adhering the glue flap 65 to the outer surface of the panel 61, as will be understood. The tubular liner 11 is squared into rectangular form and snugly fitted into the squared carton shell, as shown in FIG. 3, in a manner whereby the edges 70, 71 are in substantial abutment. Alternatively, the collapsed tubular liner and collapsed carton shell may be preassembled and squared together if that is deemed desirable or necessary.

At this stage, the contents, typically, a fluid or pulverulent material, may be poured into the open end of the carton until the desired degree of filling is reached. Then the upper end is sealed in a manner identical to that used to seal the bottom end. Accordingly, the end flaps 24-27 are first outfolded; a sealing membrane is adhered thereover; and finally the flaps 24-27 are infolded. The flaps 27 and 33 are appropriately adhered to the flaps 24 and 30 to maintain the package in a closed relationship, as should be apparent from FIG. 5.

As an important aspect of the invention, the composite package possesses substantial universality. That is to say, the outer shell 10 may be "standardized" and fabricated from comparatively lightweight and inexpensive material, while by appropriately selecting an adequate membrane material and the material from which the liner element 11 is fabricated, the final package can be individually customized to provide any requisite packaging property such as strength, moisture vapor transmission resistance (WVTR), stiffness and the like. The ultimate degree of protection will, of course, be the result of the combination of the materials selected for the shell, the liner, and the membranes.

As a further specific important aspect of the invention, with the height of the liner walls chosen to be substantially equal to the height of the shell walls, the membrane 12 will be firmly compressed or "gasketed" between the edges 75 of the liner and the infolded end flaps, thereby enhancing the leakproofness of the container and extending the shelf life of the packaged contents.

In use, when access to the packaged contents is desired, it is necessary only to remove the tear strip 40 by grasping the tab 48 and pulling it away from the carton body, as shown in FIG. 5. As is known in the art, the illustrated and described type of tear strip will have a T-shaped cross section and will tear in intermediate planes of the paperboard in the areas between the partial cuts 41, 42. In the area where the tear strip overlaps itself, that is, the area of the manufacturer's joint formed by the

adhesion of the panels 15, 19, the tear strip is provided with a rectangular breakaway portion 78 defined by partial cuts 79 (FIGS. 1 and 5) which are impressed on the opposite side of the blank from the cuts 41. Accordingly, when the forward end of the tear strip (i.e., the starting end having the tab 48) is torn from the carton body, a layer of underlying board, the breakaway portion 78, from the rearmost end of the tear strip will be carried along, as shown best in FIG. 5. As will be appreciated, when the tear strip 40 is completely removed, an independent end cap 76 is formed, which cap may be removed from the end of the carton to open the same. If all of the contents are not consumed in a single use, the carton may be closed simply by telescopically placing the end cap 76 over the projecting end of the liner 11. Advantageously, in applications requiring the carton itself to be used as a volumetric measure equal to the original volume of the carton (such as in the packaging of concentrated frozen fruit juices), the construction of the invention ensures that the volume of the container is maintained, in spite of the fact that the outer shell of the container is opened and divided by the removal of a substantial portion of its walls.

It should be understood that the specific package herein illustrated and described is intended to be representative only, as certain changes may be made therein without departing from the clear teachings of the disclosure. For example, a hinged "chest-type" cover may be used in lieu of the completely removable end cap 76 illustrated herein. In this alternative embodiment, a modified tear strip of leakproof construction extends through three contiguous walls to a hinge across the fourth wall. The removal of the modified strip would form and free a telescopically recloseable cover for pivoting movement about the hinge at the fourth wall of the carton. Accordingly, reference should be made to the following appended claims in determining the full scope of the invention.

I claim:

1. A composite package structure including:

a. an outer shell member comprising;

1. first, second, third and fourth contiguous shell sidewalls,
2. a shell glue flap of predetermined width articulated to said first wall and connecting the same to said fourth wall,
3. shell closing end flaps articulated to the opposite ends of said sidewalls;

b. an inner tubular liner member disposed snugly within said shell member and comprising comprising;

1. first, second, third and fourth liner sidewalls substantially identical in size and shape to said shell sidewalls,
2. a liner glue flap of predetermined width articulated to said first shell sidewall and connecting the same to said fourth shell sidewall;

c. flexible sheet members adhered to inner surfaces of said end flaps and sealing off the ends of said shell and liner;

1. portions of said sheet members being compressed between end edges of said liner and said end flaps;
- d. the combined widths of said shell glue flaps and said liner glue flap being substantially equal to the width of said fourth shell wall; and

e. said glue flaps being arranged in a mating nested relation with their edges in substantial abutment.

65

70

75