



US 20100326859A1

(19) **United States**

(12) **Patent Application Publication**  
**Cook et al.**

(10) **Pub. No.: US 2010/0326859 A1**

(43) **Pub. Date: Dec. 30, 2010**

(54) **BOTTLE CARRIER**

**Publication Classification**

(76) Inventors: **Alan J. Cook**, Liverpool (GB);  
**Gerald R. Koefeldt**, Sunningdale (GB)

(51) **Int. Cl.**  
**B65D 75/00** (2006.01)

(52) **U.S. Cl.** ..... **206/434**

Correspondence Address:  
**CARLSON, GASKEY & OLDS, P.C.**  
**400 WEST MAPLE ROAD, SUITE 350**  
**BIRMINGHAM, MI 48009 (US)**

(57) **ABSTRACT**

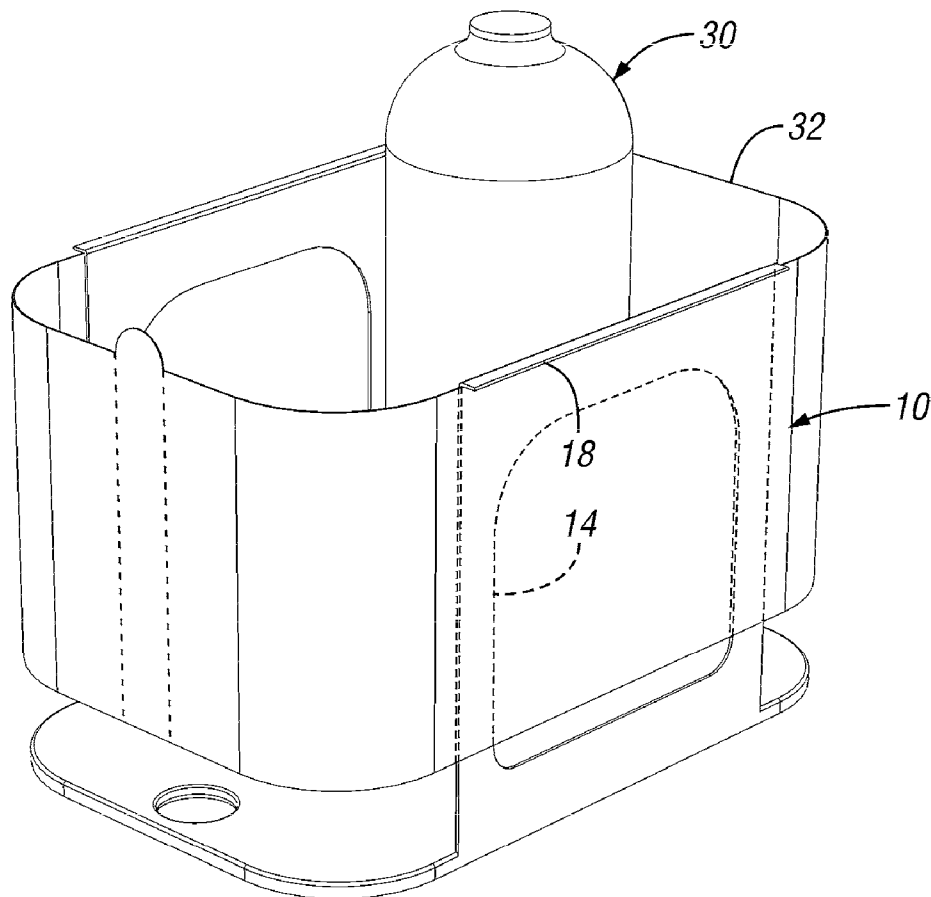
A bottle carrier includes a base wall and a pair of side walls extending upwardly from side edges of the base wall. Front and rear openings are defined at front and rear ends of the base wall. Upper edges of the side walls may protrude outwardly to form lips. A plurality of bottles may be supported on the base wall between the side walls. A wrap may be wrapped around the bottles and the side walls to retain the bottles in the carrier. The wrap may include a tear strip to facilitate removal of the wrap from the carrier.

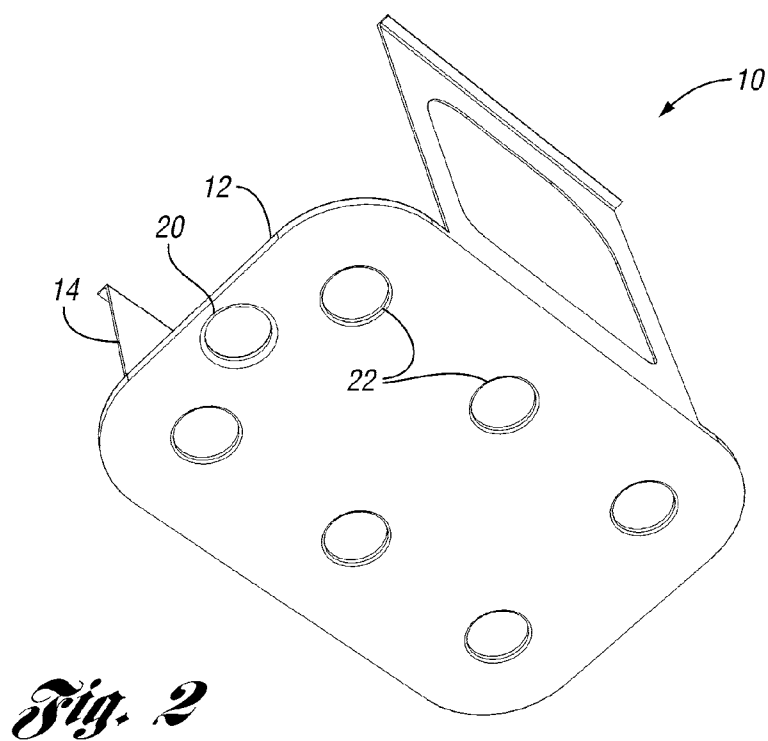
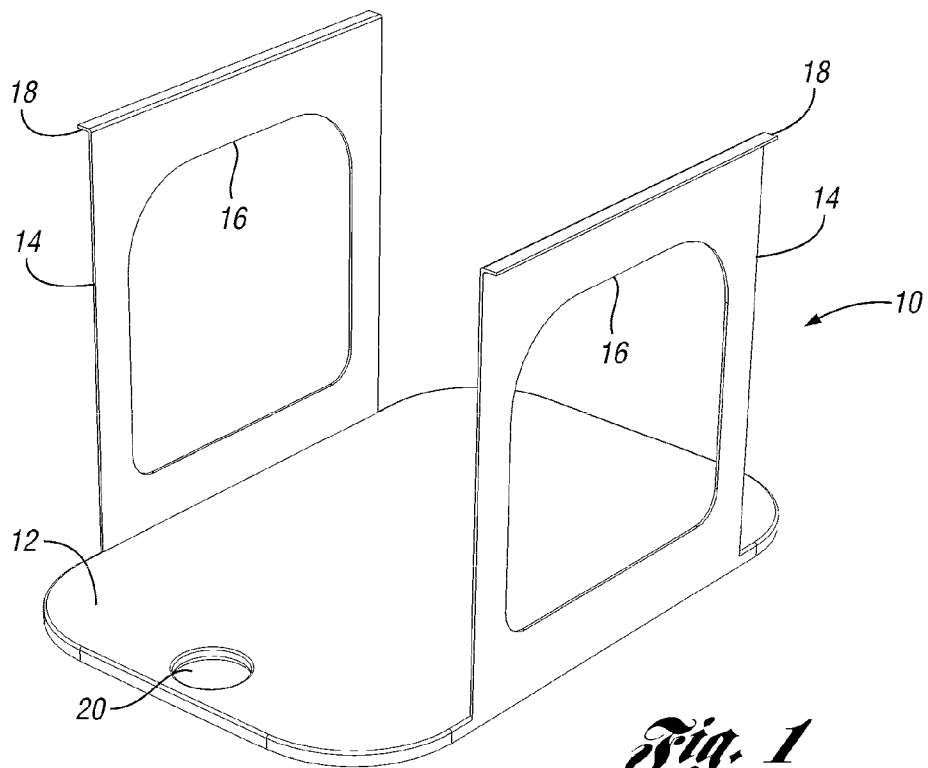
(21) Appl. No.: **12/822,414**

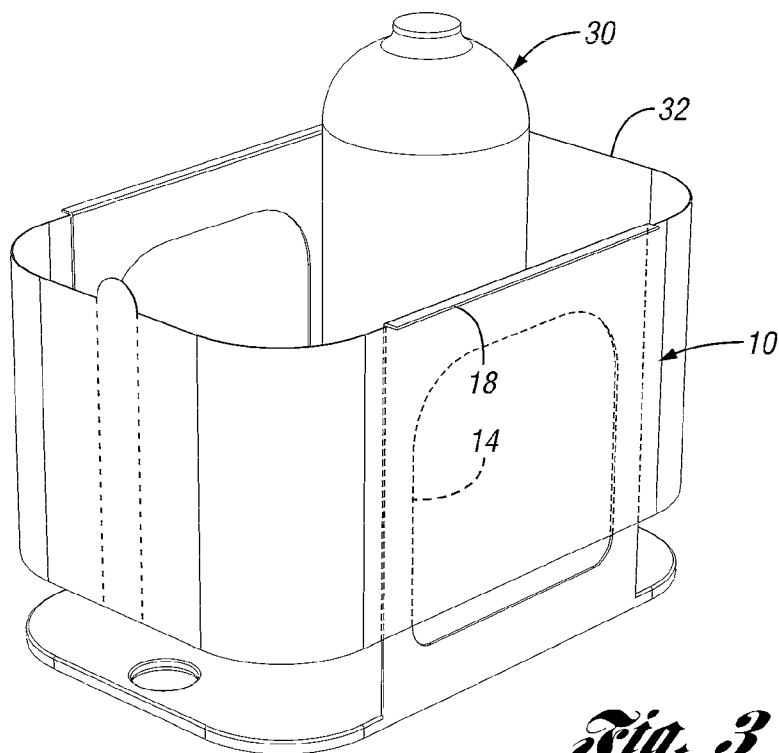
(22) Filed: **Jun. 24, 2010**

**Related U.S. Application Data**

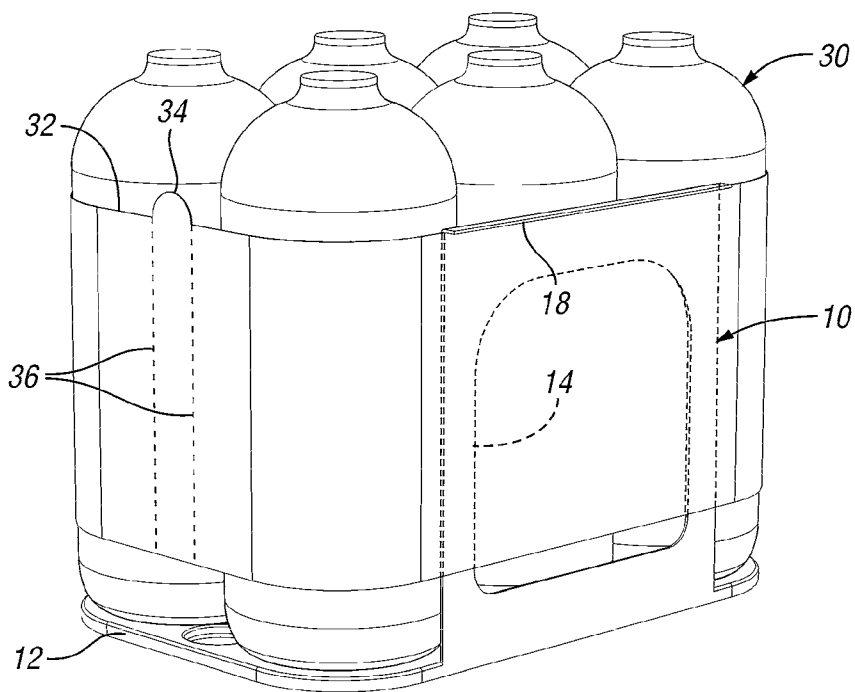
(60) Provisional application No. 61/220,190, filed on Jun. 24, 2009.



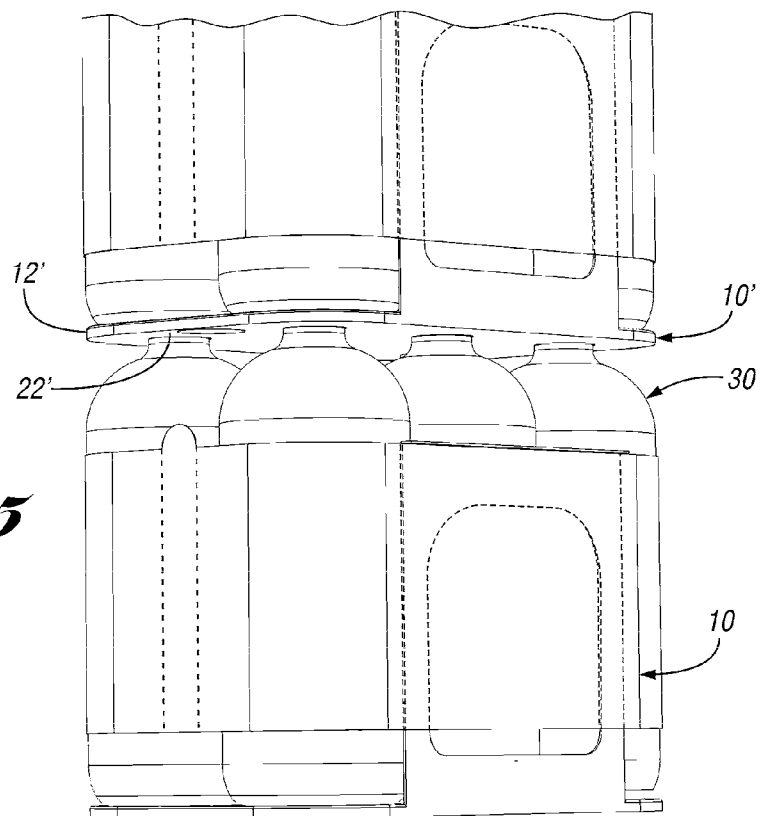




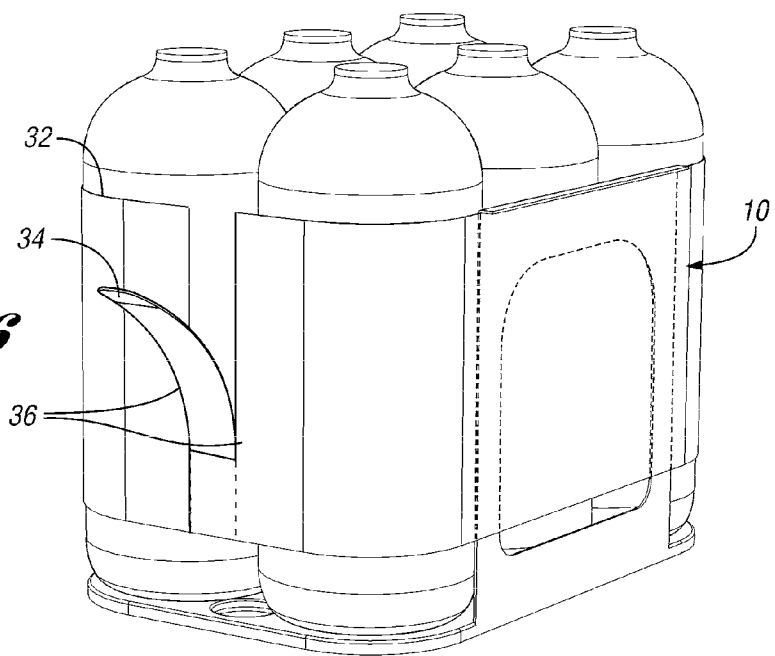
*Fig. 3*



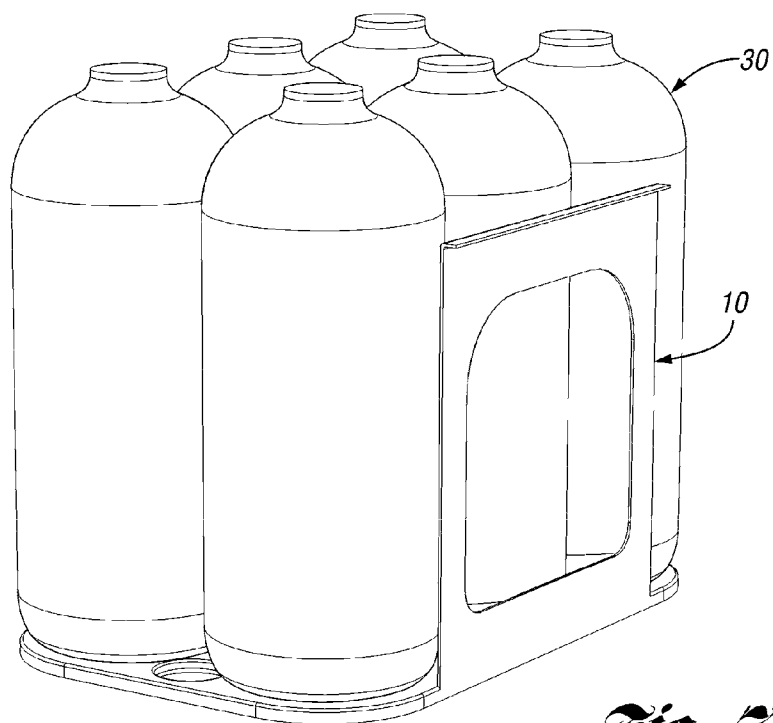
*Fig. 4*



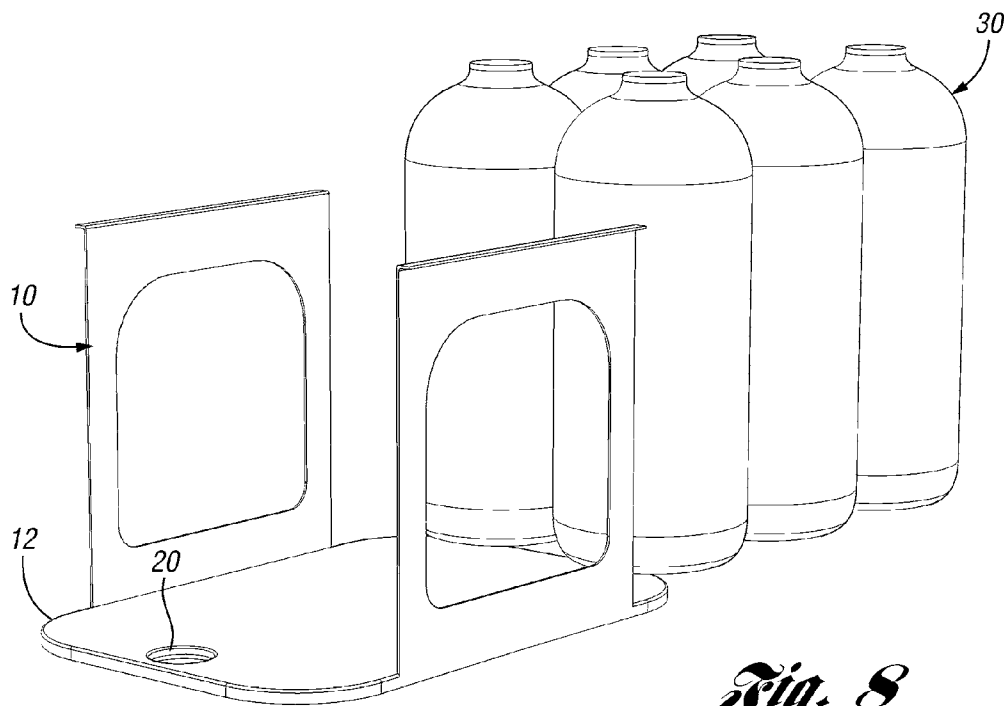
*Fig. 5*



*Fig. 6*



*Fig. 7*



*Fig. 8*

**BOTTLE CARRIER**

[0001] This application claims priority to U.S. Provisional Application Ser. No. 61/220,190, filed Jun. 24, 2009.

**BACKGROUND OF THE INVENTION**

[0002] The present invention relates generally to bottle carriers.

[0003] Bottles, such as beverage bottles, are often shipped to stores in a short corrugated cardboard tray. The bottles are shrink-wrapped to the tray. The bottles, tray and shrink wrap are shipped as a unit. The cardboard tray is often not recycled. Further, for sale of individual bottles, it is not easy to remove the bottles from this package and put them on a shelf.

**SUMMARY**

[0004] A bottle carrier includes a base wall and a pair of side walls extending upwardly from side edges of the base wall. Front and rear openings are defined at front and rear ends of the base wall between the side walls. Upper edges of the side walls may protrude outwardly to form lips.

[0005] A plurality of bottles may be supported on the base wall between the side walls. A wrap, such as shrink-wrap, may be wrapped around the bottles and the side walls, below the lips of the side walls to retain the bottles in the carrier. The wrap may include a tear strip to facilitate removal of the wrap from the carrier. After removing the wrap, the bottles can be slide off the base wall onto a shelf. The carrier can then be recycled.

**BRIEF DESCRIPTION OF THE DRAWINGS**

[0006] FIG. 1 is a perspective view of a bottle carrier according to one embodiment of the present invention.

[0007] FIG. 2 is a bottom perspective view of the bottle carrier of FIG. 1.

[0008] FIG. 3 shows the bottle carrier of FIG. 1 with a bottle placed therein and with shrink-wrap.

[0009] FIG. 4 illustrates the bottle carrier with a plurality of bottles therein and with shrink-wrap retaining the bottles in the carrier.

[0010] FIG. 5 shows a pair of stacked, loaded bottle carriers.

[0011] FIG. 6 shows a first step in unloading the bottles from the bottle carrier.

[0012] FIG. 7 shows a second step in unloading the bottles from the carrier.

[0013] FIG. 8 shows a third step in unloading the bottles from the carrier

**DETAILED DESCRIPTION OF THE PREFERRED EMBODIMENT**

[0014] An bottle carrier 10 according to one embodiment of the present invention is shown in FIGS. 1-8.

[0015] Referring to FIGS. 1 and 2, the bottle carrier 10 includes a base 12 and side walls 14 extending upward from side edges of the base 12. The side walls 14 can be integrally formed with the base 12, such as by thermoforming, injection molding or other suitable process. The side walls 14 can include large window openings 16 (i.e. the area of the window openings 16 is larger than the remaining area of the side walls 14). A lip 18 projects outwardly from the uppermost edges of the side walls 14. As shown, the side walls 14 may extend

solely from the side edges of the base 12 and nothing extends upward from a rear edge of the base 12. Further, the front edge of the base 12 may also be free of any upward protrusion, as are the rounded corners of the base 12. The upper surface of the base 12 is generally flat and smooth, other than an optional hole 20 (or other handle) formed near one at least end of the base 12. As shown in FIG. 2, cap-receiving recesses 22 are formed in the lower surface of the base 12.

[0016] Referring to FIGS. 3 and 4, bottles 30, such as beverage bottles 30, are placed on the base 12 of the carrier 10. A wrap, such as shrink wrap 32, is wrapped around the bottles 30 and side walls 14 to secure the bottles 30 to the carrier 10. The wrap 32 may be of the same material and type as the plastic shrink wrap currently used for containing large packs of beverage bottles in corrugated cardboard trays. The wrap 32 is retained on the side walls 14 in part by the lips 18 at the uppermost edges of the side walls 14. Referring to FIG. 4, the wrap 32 includes a tear strip 34 with tear lines 36 (weakened portions, such as perforated portions) to facilitate removal of the wrap 32.

[0017] As shown in FIG. 5, the loaded carrier 10 can support a similar loaded carrier 10 thereon, with the caps of the bottles 30 received in the recesses 22' of the base 12' of the upper carrier 10' to increase the stability of the stack.

[0018] The loaded carriers 10 and bottles 30 are shipped to a store in this manner. At the store, the carrier 10 and bottles 30 can be set on a shelf. The tear strip 34 is then pulled downward as shown in FIG. 6, thereby separating the tear strip 34 from the remainder of the wrap 32 along the tear lines 36 and thereby splitting the wrap 32 permitting the wrap 32 to be removed, as shown in FIG. 7.

[0019] The carrier 10 is then slid out from under the bottles 30 by pulling on the handle 20 in the base 12, leaving the bottles 30 on the shelf in the store. Thus, the bottles 30 can be loaded onto the store shelves more easily than with prior art methods. The carrier 10 can then be reused or recycled.

[0020] In accordance with the provisions of the patent statutes and jurisprudence, exemplary configurations described above are considered to represent a preferred embodiment of the invention. However, it should be noted that the invention can be practiced otherwise than as specifically illustrated and described without departing from its spirit or scope.

What is claimed is:

1. A bottle carrier comprising:
  - a base wall; and
  - a pair of opposed side walls extending upward from side edges of the base wall, the side walls defining an open front end and an open rear end of the carrier.
2. The bottle carrier of claim 1 wherein the sidewalls each include a lip projecting outwardly from an upper edge.
3. The bottle carrier of claim 2 wherein each side wall includes a large opening therethrough.
4. The bottle carrier of claim 3 wherein the base includes a plurality of cap-receiving indentations on a bottom surface.
5. The bottle carrier of claim 4 further including a plurality of bottles on the base.
6. The bottle carrier of claim 5 further including a wrap around the bottles and the exterior of the side walls below the upper lips of the side walls.
7. The bottle carrier of claim 6 wherein the wrap includes a tear strip.
8. The bottle carrier of claim 7 wherein the front and rear openings are sufficiently large for the plurality of bottles to slide out of the bottle carrier after removal of the wrap.
9. The bottle carrier of claim 1 wherein an upper surface of the base wall is generally flat and smooth.

**10.** The bottle carrier of claim **1** further including a plurality of cap-receiving indentations on a lower surface.

**11.** The bottle carrier of claim **1** wherein the base wall includes a rear edge with no upward projections along the rear edge.

**12.** The bottle carrier of claim **11** wherein the base wall includes a front edge with no upward projections along the front edge.

**13.** The bottle carrier of claim **12** wherein the base wall includes rounded corner edges between the side edges and front and rear edges, with no upward projections along the rounded corner edges.

**14.** The bottle carrier of claim **1** wherein the base wall and side walls are thermoformed from a single sheet of plastic.

\* \* \* \* \*