



(86) Date de dépôt PCT/PCT Filing Date: 2003/12/10
 (87) Date publication PCT/PCT Publication Date: 2004/07/08
 (45) Date de délivrance/Issue Date: 2014/02/11
 (85) Entrée phase nationale/National Entry: 2005/06/14
 (86) N° demande PCT/PCT Application No.: EP 2003/013983
 (87) N° publication PCT/PCT Publication No.: 2004/057040
 (30) Priorité/Priority: 2002/12/23 (DE102 60 737.0)

(51) Cl.Int./Int.Cl. *C22B 1/10* (2006.01),
B01J 8/18 (2006.01), *B01J 8/26* (2006.01),
C21B 13/00 (2006.01), *C22B 34/12* (2006.01),
C22B 5/14 (2006.01), *F27B 15/02* (2006.01),
F27B 15/10 (2006.01)

(72) Inventeurs/Inventors:
 NUBER, DIRK, DE;
 STROEDER, MICHAEL, DE;
 STOCKHAUSEN, WERNER, DE;
 BEYZAVI, ALI-NAGHI, DE;
 FORMANEK, LOTHAR, DE;
 HIRSCH, MARTIN, DE

(73) Propriétaire/Owner:

(54) Titre : PROCEDE ET INSTALLATION METTANT EN OEUVRE UN LIT FLUIDISE POUR LE TRAITEMENT
 THERMIQUE DE SOLIDES CONTENANT DU TITANE

(54) Title: FLUIDIZED BED METHOD AND PLANT FOR THE HEAT TREATMENT OF SOLIDS CONTAINING TITANIUM

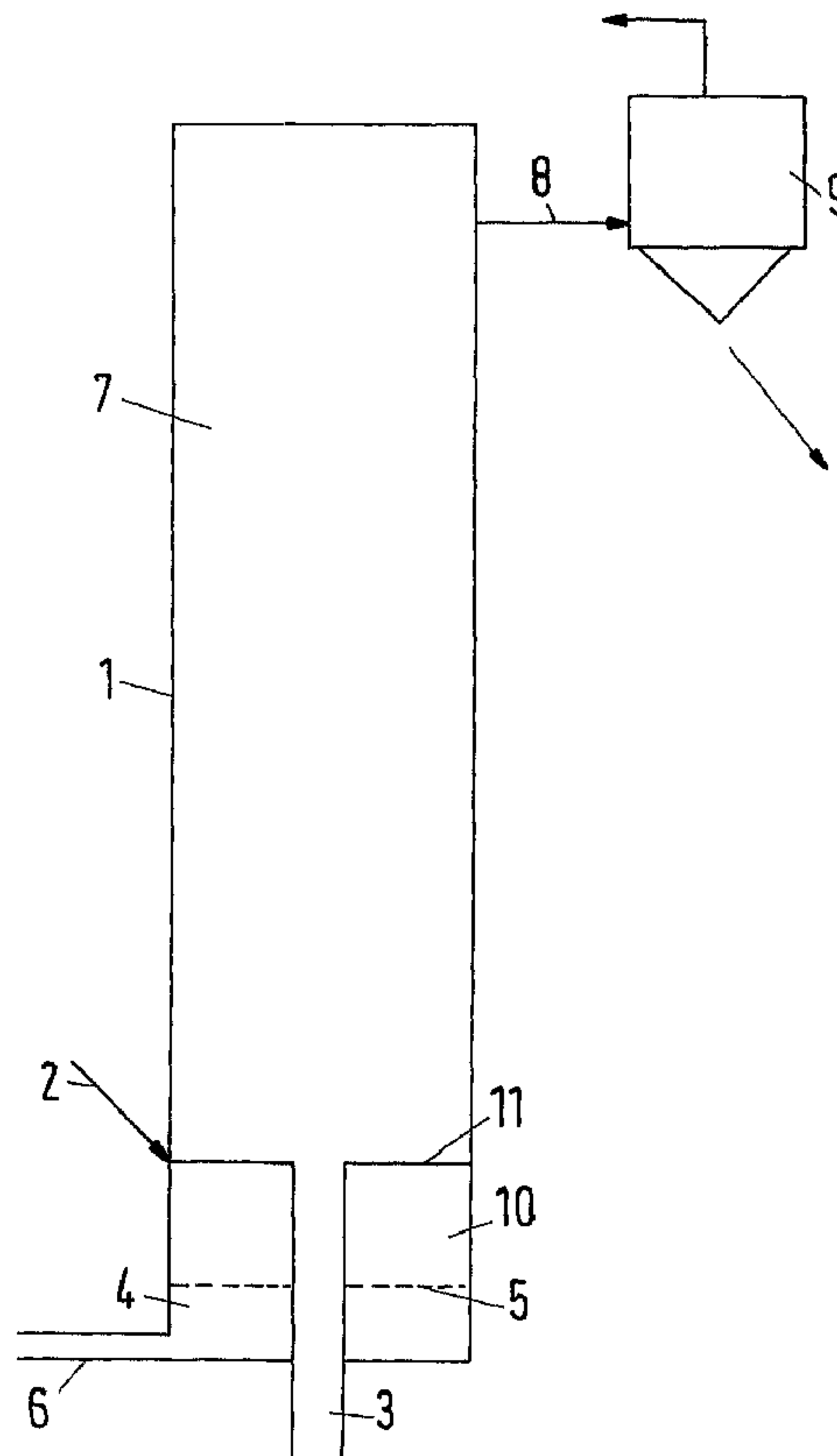

(57) Abrégé/Abstract:

The present invention relates to a method and a plant for the heat treatment of solids containing titanium and possibly further metal oxides, in which fine-grained solids are heated to a temperature of 700 to 950 °C in a fluidized bed reactor (1). To improve the

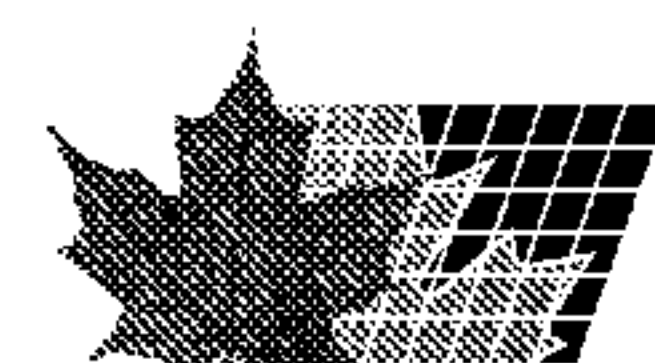

(73) Propriétaires(suite)/Owners(continued):OUTOTEC OYJ, FI

(74) Agent: ROBIC

(57) Abrégé(suite)/Abstract(continued):

energy utilization, it is proposed to introduce a first gas or gas mixture from below through a gas supply tube (3) into a mixing chamber (7) of the reactor (1), the gas supply tube (3) being at least partly surrounded by a stationary annular fluidized bed (10) which is fluidized by supplying fluidizing gas. The gas velocities of the first gas or gas mixture as well as of the fluidizing gas for the annular fluidized bed (10) are adjusted such that the particle Froude numbers in the gas supply tube (3) are between 1 and 100, in the annular fluidized bed (10) between 0.02 and 2 and in the mixing chamber (7) between 0.3 and 30.

(12) INTERNATIONAL APPLICATION PUBLISHED UNDER THE PATENT COOPERATION TREATY (PCT)

(19) World Intellectual Property
Organization
International Bureau



(43) International Publication Date
8 July 2004 (08.07.2004)

PCT

(10) International Publication Number
WO 2004/057040 A1

(51) International Patent Classification⁷: C22B 1/10, 5/14,
34/12, F27B 15/02, 15/10, B01J 8/18, C21B 13/00

(21) International Application Number:
PCT/EP2003/013983

(22) International Filing Date:
10 December 2003 (10.12.2003)

(25) Filing Language: English

(26) Publication Language: English

(30) Priority Data:
102 60 737.0 23 December 2002 (23.12.2002) DE

(71) Applicant (for all designated States except US): **OUT-
OKUMPU OYJ** [FI/FI]; Riihitontuntie 7, FIN-02200 Es-
poo (FI).

(72) Inventors; and

(75) Inventors/Applicants (for US only): **NUBER, Dirk**
[DE/DE]; Haingrabenstrasse 26, 60488 Frankfurt am Main

(DE). **STRÖDER, Michael** [DE/DE]; Dürerstrasse 77,
61267 Neu-Anspach (DE). **STOCKHAUSEN, Werner**
[DE/DE]; An der Bleiche 4, 61118 Bad Vilbel (DE).
BEYZAVI, Ali-Naghi [DE/DE]; Peter-Henlein-Strasse
22, 60435 Frankfurt am Main (DE). **FORMANEK,
Lothar** [DE/DE]; Libellenweg 67, 60529 Frankfurt am
Main (DE). **HIRSCH, Martin** [DE/DE]; Am Vogelschutz
5, 61381 Friedrichsdorf (DE).

(74) Agent: **KEIL & SCHAAFHAUSEN**; Cronstettenstrasse
66, 60322 Frankfurt am Main (DE).

(81) Designated States (*national*): AE, AG, AL, AM, AT, AU,
AZ, BA, BB, BG, BR, BW, BY, BZ, CA, CH, CN, CO, CR,
CU, CZ, DE, DK, DM, DZ, EC, EE, EG, ES, FI, GB, GD,
GE, GH, GM, HR, HU, ID, IL, IN, IS, JP, KE, KG, KP, KR,
KZ, LC, LK, LR, LS, LT, LU, LV, MA, MD, MG, MK, MN,
MW, MX, MZ, NI, NO, NZ, OM, PG, PH, PL, PT, RO, RU,
SC, SD, SE, SG, SK, SL, SY, TJ, TM, TN, TR, TT, TZ, UA,
UG, US, UZ, VC, VN, YU, ZA, ZM, ZW.

[Continued on next page]

(54) Title: FLUIDIZED BED METHOD AND PLANT FOR THE HEAT TREATMENT OF SOLIDS CONTAINING TITANIUM

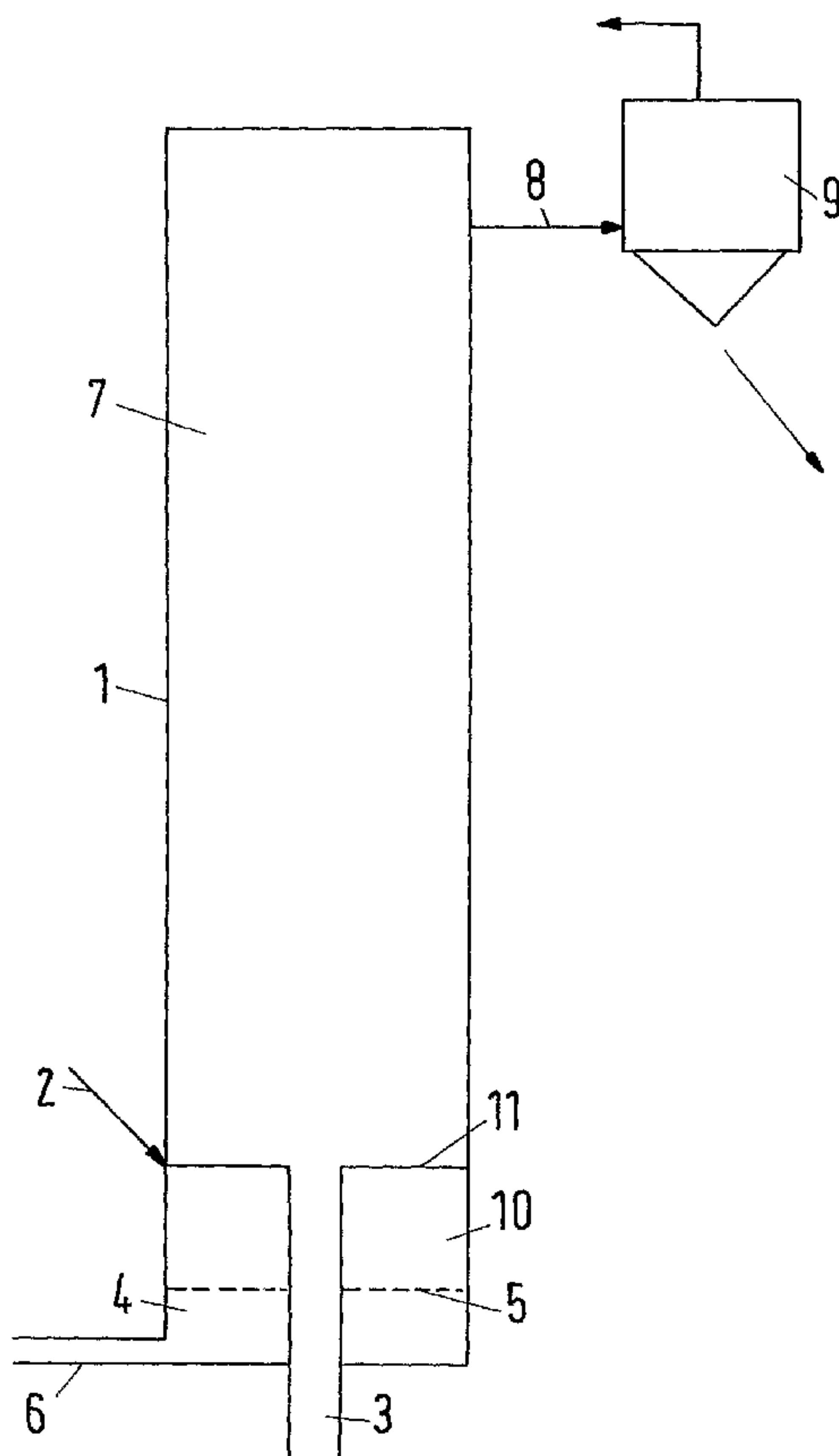

(57) Abstract: The present invention relates to a method and a plant for the heat treatment of solids containing titanium and possibly further metal oxides, in which fine-grained solids are heated to a temperature of 700 to 950 °C in a fluidized bed reactor (1). To improve the energy utilization, it is proposed to introduce a first gas or gas mixture from below through a gas supply tube (3) into a mixing chamber (7) of the reactor (1), the gas supply tube (3) being at least partly surrounded by a stationary annular fluidized bed (10) which is fluidized by supplying fluidizing gas. The gas velocities of the first gas or gas mixture as well as of the fluidizing gas for the annular fluidized bed (10) are adjusted such that the particle Froude numbers in the gas supply tube (3) are between 1 and 100, in the annular fluidized bed (10) between 0.02 and 2 and in the mixing chamber (7) between 0.3 and 30.

WO 2004/057040 A1

WO 2004/057040 A1

(84) Designated States (regional): ARIPO patent (BW, GH, GM, KE, LS, MW, MZ, SD, SL, SZ, TZ, UG, ZM, ZW), Eurasian patent (AM, AZ, BY, KG, KZ, MD, RU, TJ, TM), European patent (AT, BE, BG, CH, CY, CZ, DE, DK, EE, ES, FI, FR, GB, GR, HU, IE, IT, LU, MC, NL, PT, RO, SE, SI, SK, TR), OAPI patent (BF, BJ, CF, CG, CI, CM, GA, GN, GQ, GW, ML, MR, NE, SN, TD, TG).

— *before the expiration of the time limit for amending the claims and to be republished in the event of receipt of amendments*

For two-letter codes and other abbreviations, refer to the "Guidance Notes on Codes and Abbreviations" appearing at the beginning of each regular issue of the PCT Gazette.

Published:

— *with international search report*

- 1 -

FLUIDIZED BED METHOD AND PLANT FOR THE HEAT TREATMENT OF SOLIDS CONTAINING TITANIUM

Technical Field

5

The present invention relates to a method for the heat treatment of solids containing titanium, in which fine-grained solids are treated at a temperature of 700 to approximately 950°C in a fluidized bed reactor, and to a corresponding plant.

10

Such methods and plants are used for instance for the reduction of ilmenite ($x \cdot \text{TiO}_2 y \cdot \text{FeO} z \cdot \text{Fe}_2\text{O}_3$). For this purpose, ilmenite is treated for example in rotary kilns (for instance the SLRN method) with suitable carbons at temperatures of between 850 and 1200°C. Depending on the type of treatment, the reduction of the iron may be undertaken in a further processing stage to FeO or to metallic iron. For example, a high degree of metallization of the iron of up to 97% in the reduced ilmenite is the target for the so-called Becher method.

15

However, the metallization of the iron at such high temperatures of 1060 to approximately 1200°C leads to the formation of undesired complex compounds, known as M_3O_5 phases, in the ilmenite grain, the letter "M" generally standing for metal, such as for example Ti_2MgO_5 , Ti_2MnO_5 or Ti_2FeO_5 . Since these compounds are for example neither soluble in sulphuric acid nor in hydrochloric acid, they cannot be dissolved, or only with difficulty, in the hydrometallurgical process stages following the reduction. This has the consequence that, apart from the desired TiO_2 , undesired impurities remain in the solid product, known as "synthetic rutile". The production of these undesired compounds is in this case dependent on the temperature and the retention time of the ilmenite in the reduction zone, which in a rotary kiln for example is four to five hours. For many iron-rich ilmenites, the wet-metallurgical enrichment stage is indispensable to produce an end product with good selling properties (synthetic rutile).

20

25

30

- 2 -

Furthermore, methods and plants as mentioned above are also used for the magnetic roasting of ilmenite. For this purpose, previously ilmenite has been subjected to dust-free, for example pre-heated, air through a tuyere bottom (gas distributor) in a circulating fluidized bed. In this case it is found to be disadvantageous that dust-laden gas cannot be used for the fluidizing of the solids. A further disadvantage of this known method is that the combustion profile is unfavourable and, furthermore, there is no utilization of the waste heat of the solids. In part-load operation, there is also the risk that, in spite of the sophisticated mechanical feature of the tuyere bottom, fine-grained solids can undesirably fall through it. The retention time for the solids of 20 to 30 minutes, necessary for process engineering reasons, can be achieved only with a very high pressure loss in the reactor, which in turn leads to undesired pulsations of the fluidized bed. Therefore, these plants must be designed for high dynamic loads in order to be able to withstand the forces occurring during operation.

Reactors with either a stationary fluidized bed or a circulating fluidized bed are generally known for the heat treatment of solids. However, the utilization of the reducing agent and the energy utilization achieved when using a stationary fluidized bed are in need of improvement. One reason for this is that the mass and heat transfer is moderate on account of the comparatively low degree of fluidization. Therefore, an internal combustion that occurs during the magnetic roasting can also only be controlled with difficulty. Furthermore, pre-heating of the solids or cooling of the product can hardly be integrated in a suspension heat exchanger or a fluidized bed cooler, because dust-laden gases are rather not admitted to the fluidizing nozzles of the stationary fluidized bed. Due to the high degree of fluidization, circulating fluidized beds on the other hand have better conditions for mass and heat transfer and allow the integration of a suspension heat exchanger or product cooling, but are restricted in terms of their solids retention time due to the relatively high degree of fluidization.

Therefore, it is the object of the present invention to provide a method for the heat treatment of solids containing titanium which can be carried out more efficiently and is distinguished in particular by good conditions for heat and mass transfer.

10 In accordance with the invention, this object is achieved by a method as mentioned above in which a first gas or gas mixture is introduced from below through at least one preferably centrally arranged gas supply tube (central tube) into a mixing chamber region of the reactor, the central tube being at least partly surrounded by a stationary annular fluidized bed which is fluidized by supplying fluidizing gas, and in which the gas velocities of the first gas or gas mixture as well as of the fluidizing gas for the annular fluidized bed are adjusted such that the particle Froude numbers in the central tube are between 1 and 100, in the annular fluidized bed between 0.02 and 2 and in the mixing chamber between 0.3 and 30.

20 More precisely, the invention provided is a method for the heat treatment of solids containing titanium, in which fine-grained solids are treated at a temperature of 700 to approximately 950°C in a fluidized bed reactor, characterized in that a first gas or gas mixture is introduced from below through at least one gas supply tube into a mixing chamber of the reactor, the gas supply tube being at least partly surrounded by a stationary annular fluidized bed which is fluidized by supplying fluidizing gas, and that the gas velocities of the first gas or gas mixture as well as of the fluidizing gas for the stationary annular fluidized bed are adjusted such that the particle Froude numbers in the gas supply tube are between 1 and 100, in the stationary annular fluidized bed between 0.02 and 2 and in the mixing chamber between 0.3 and 30.

In the method of the invention, the advantages of a stationary fluidized bed, such as a sufficiently long solids retention time, and the advantages of a

3a

circulating fluidized bed, such as a good mass and heat transfer, can surprisingly be combined with each other during the heat treatment, such as for example the reduction or magnetic roasting of solids containing titanium, while the disadvantages of both systems are avoided. When passing through the upper region of the central tube, the first gas or gas mixture entrains solids from the annular stationary fluidized bed, which is referred to as the annular fluidized bed, into the mixing chamber, so that, due to the high speed differences between the solids and the first gas, an intensively mixed suspension is formed and an optimum heat and mass transfer between the two phases is achieved.

10 By correspondingly adjusting the bed height in the annular fluidized bed as well

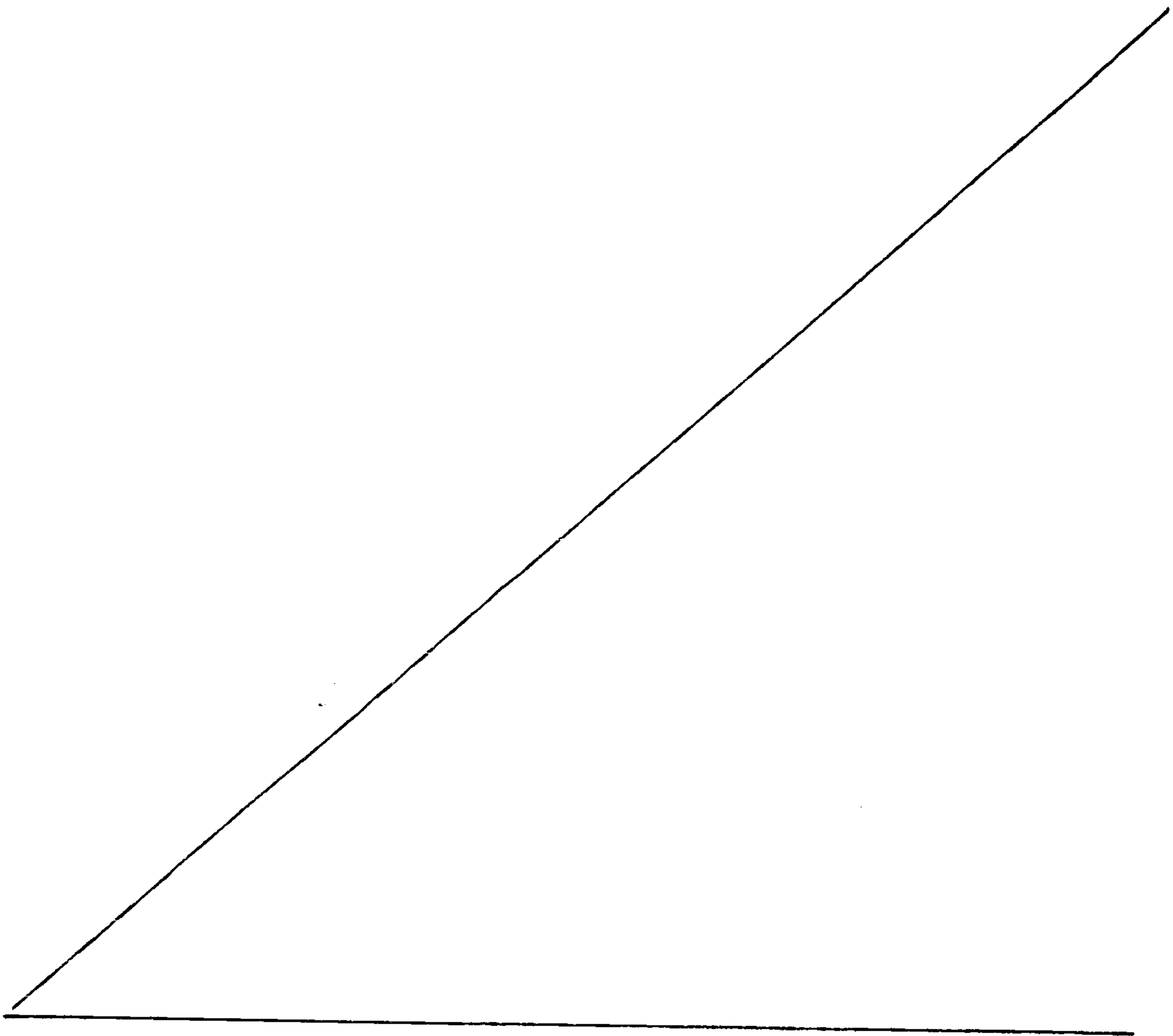

- 4 -

ingly adjusting the bed height in the annular fluidized bed as well as the gas velocities of the first gas or gas mixture and of the fluidizing gas, the solids load of the suspension above the orifice region of the central tube can be varied within wide ranges, so that the pressure loss of the first gas between the orifice region

5 of the central tube and the upper outlet of the mixing chamber can be between 1 mbar and 100 mbar. In the case of high solids loading of the suspension in the mixing chamber, a large part of the solids will separate out from the suspension and fall back into the annular fluidized bed. This recirculation is called internal solids recirculation, the stream of solids circulating in this internal circulation

10 normally being significantly larger than the amount of solids supplied to the reactor from outside. The (smaller) amount of not precipitated solids is discharged from the mixing chamber together with the first gas or gas mixture. The retention time of the solids in the reactor can be varied within a wide range by the selection of the height and cross-sectional area of the annular fluidized bed and

15 be adapted to the desired heat treatment. The amount of solids entrained from the reactor with the gas stream is completely or at least partly recirculated to the reactor, with the recirculation expediently being fed into the stationary fluidized bed. The stream of solids thus recirculated to the annular fluidized bed normally lies in the same order of magnitude as the stream of solids supplied to the reactor

20 from outside. With the method of the invention, on the one hand a high solids loading, of for example 30 kg of solid per kg of gas, and at the same time a particularly good mass and heat transfer can consequently be achieved. Apart from the excellent utilization of energy, another advantage of the method in accordance with the invention consists in the possibility of quickly, easily and reliably adjusting the transfer of energy of the method and the mass transfer to the

25 requirements by changing the flow velocities of the first gas or gas mixture and of the fluidizing gas. Due to the high solids loading on the one hand and the good mass and heat transfer on the other hand, excellent conditions for a virtually complete internal combustion of the fuel additionally introduced into the reactor, for example in the case of magnetic roasting, are obtained above the ori-

30

- 5 -

fice region of the central tube. There can, for instance, be performed a virtually complete combustion of natural gas close to the ignition temperature and/or with little excess of oxygen without local temperature peaks being obtained.

- 5 To ensure an effective heat and mass transfer in the mixing chamber and a sufficient internal solids recirculation in the reactor, the gas velocities of the first gas mixture and of the fluidizing gas are preferably adjusted for the fluidized bed such that the dimensionless particle Froude numbers (Fr_p) are 1.15 to 20, in particular approximately 12 to 15, in the central tube, 0.115 to 1.15, in particular
- 10 approximately 0.2 to 0.4, in the annular fluidized bed, and/or 0.37 to 3.7, in particular approximately 1.4, in the mixing chamber. The particle Froude numbers are each defined by the following equation:

$$Fr_p = \frac{u}{\sqrt{\frac{(\rho_s - \rho_f)}{\rho_f} * d_p * g}}$$

15

with

u = effective velocity of the gas flow in m/s

ρ_f = effective density of the fluidizing gas in kg/m^3

20 ρ_s = density of a solid particle in kg/m^3 (apparent density)

d_p = mean diameter in m of the particles of the reactor inventory (or the secondary agglomerates forming) during operation of the reactor

g = gravitational constant in m/s^2 .

- 25 When using this equation it should be considered that d_p does not indicate the mean diameter (d_{50}) of the material used, but the mean diameter of the reactor inventory formed during the operation of the reactor, which can differ significantly from the mean diameter of the material used (primary particles). It is also

- 6 -

possible for particles (secondary particles) with a mean diameter of 20 to 30 μm to be formed for instance during the heat treatment from very fine-grained material with a mean diameter of, for example, 3 to 10 μm . On the other hand, some materials, for example ores, are decrepitated during the heat treatment.

5

In a development of the idea of the invention, it is proposed to adjust the bed height of solids in the reactor such that the annular fluidized bed extends at least partly beyond the upper orifice end of the central tube by a few centimetres, and thus solids are constantly introduced into the first gas or gas mixture and entrained by the gas stream to the mixing chamber located above the orifice region of the central tube. In this way, there is achieved a particularly high solids loading of the suspension above the orifice region of the central tube, which allows for example a complete combustion under difficult conditions.

10

According to a further embodiment of the present invention, the central tube has apertures on its shell surface, for example in the form of slots, so that during the operation of the reactor solids constantly get into the central tube through the apertures and are entrained by the first gas or gas mixture from the central tube into the mixing chamber.

15

By means of the method in accordance with the invention, all kinds of ores containing titanium, in particular also those which additionally contain iron oxides, can be effectively heat-treated. In particular, the method is suitable for the reduction of ilmenite. The intensive mass and heat transfer and the adjustable solids retention time in the reactor allow a particularly high degree of pre-reduction of the iron in the ilmenite to be achieved, so that the formation of complex M_3O_5 phases is virtually prevented. This allows the retention time in a downstream final reduction stage to be shortened, whereby the formation of M_3O_5 is further reduced. Furthermore, the method is also suitable in particular for the magnetic

20

roasting of ilmenite.

25

30

- 7 -

The generation of the amount of heat necessary for the operation of the reactor can be effected in any way known to the expert for this purpose.

5 According to a preferred embodiment of the present invention, it is provided that, for the reduction, the reactor is supplied with hydrogen-containing gas, which, for example with a hydrogen content of 75 to 100%, in particular of 85 to 95%, is introduced through the central tube and/or into the annular fluidized bed. The hydrogen-containing gas may contain between 0 and 5%, in particular between
10 0.3 and 4.0%, of water vapour and between 5 and 10%, in particular between 7 and 8%, of nitrogen. The hydrogen-containing gas is preferably introduced into the reactor with a temperature of between 820 and 900°C, in particular between 840 and 880°C.

15 The energy utilization can be improved in the case of the method according to the invention by at least part of the exhaust gas of a second reactor, which is provided downstream of the reactor and in which the solids are further reduced, being supplied to the first reactor through the central tube. The dust-containing exhaust gases, which leave the downstream second reactor still with a usable
20 residual content of reducing gas at a temperature of for example approximately 850°C, can consequently be used again directly in the method according to the invention. The recirculation of the exhaust gases through the central tube is accompanied by the advantage that, by contrast with recirculation via the gas distributor, here there is no risk of the central tube being blocked, since it has a
25 larger diameter than the apertures of the gas distributor.

The amount of iron contained in the solids in the (first) reactor is preferably reduced, i.e. metallized, to at least 70%, in particular to approximately 80%, and reduced in the downstream second reactor to at least 90%, in particular to ap-
30 proximately 97%.

- 8 -

If, following re-processing by separation of the solids, cooling and separation of the water, at least part of the exhaust gas of the reactor is compressed and heated up and supplied to the reactor through the gas distributor into the annular fluidized bed, and possibly additionally via the central tube, the reducing gas can be used repeatedly in circulation.

In a development of the idea of the invention, it is provided that a separating stage, for example a cyclone or the like, for separating the solids from the exhaust gas is respectively provided downstream of the (first) reactor and of the possibly downstream second reactor, and that the separated solids are at least partly supplied to the stationary fluidized beds of the reactors. In this way, the level of the solids in the stationary annular fluidized bed of the first reactor can be controlled or deliberately varied for instance, while excess solids are passed on to the second reactor.

In accordance with a preferred embodiment of the present invention, it is provided in the case of the magnetic roasting of ilmenite to supply the reactor with fuel which, by its combustion within the reactor with an oxygen-containing gas, completely or at least partly generates the amount of heat required for the heat treatment. In the case of the last-mentioned alternative, the other part of the required amount of heat can then be covered by supplying hot gases or pre-heated solids. While solid fuel, such as coal, or liquid fuel, for example liquid hydrocarbons, is supplied to the reactor preferably via a corresponding feed conduit directly into the annular fluidized bed or the mixing chamber, gaseous fuels, for example natural gas, can either be introduced via a corresponding feed conduit into the annular fluidized bed, via lances or the like into a reactor region above the annular fluidized bed (mixing chamber) or through a conduit into the central tube and from there together with oxygen-containing gas into the reactor. In this case, the strong turbulence in the central tube can be used for

- 9 -

pre-mixing gaseous fuels and oxygen-containing gas, while ignition and combustion take place in the mixing chamber.

5 In order to ensure complete combustion of the fuel, the reactor is preferably supplied with oxygen-containing gas, for example compressed and pre-heated ambient air. It has turned out to be advantageous in this respect to operate the reactor at a pressure of 0.8 to 10 bar and particularly preferably at atmospheric pressure.

10 In a development of the idea of the invention, it is proposed to cover at least part of the energy demand of the reactor by supplying possibly dust-laden exhaust gases from a cooling stage downstream of the reactor with a separator, for example a cyclone. Thus, the necessary demand for fresh fuel can be decreased distinctly or even be eliminated completely. This procedure is particularly rec-
15 ommendable in those methods in which, after the heat treatment, intense cooling of the solids is carried out, since large amounts of exhaust gas at high temperature are formed thereby. For example, solids can be removed from the reactor from the annular fluidized bed and supplied to a cooling stage, in particular to a suspension heat exchanger, which may be designed as a venturi heat ex-
20 changer or as a rising conduit, in which the solids are suspended in a gaseous cooling medium, such as air, and to a downstream separator. The dust-containing exhaust gas of the separator is in this case preferably supplied to the reactor via the central tube, so that expensive dedusting can be omitted. If air or some other oxygen-containing gas is chosen as the cooling medium, it can be
25 used in the reactor for the combustion.

In order to reduce the energy demand of the method further, preferably at least part of the exhaust gases of the reactor is largely separated from solids in a downstream separator and supplied to a pre-heating stage upstream of the re-
30 actor. The pre-heating stage may comprise for example a heat exchanger, such

- 10 -

as a venturi dryer, and a separator, such as a cyclone or the like. The solids supplied to the reactor are in this way dried and pre-heated, whereby the heat treatment in the reactor is facilitated. Multi-stage solids pre-heating is also possible, the exhaust gas of the reactor being cooled in stages.

5

In accordance with a preferred embodiment, the amount of solids discharged from the reactor with the gas stream is completely or at least partly returned again into the reactor after the separation of exhaust gases in a separator, the return expediently taking place into the stationary annular fluidized bed. The stream of solids returned into the annular fluidized bed in this way is normally of the same order of magnitude as the stream of solids supplied to the reactor from outside. Together with a stream of solids removed from the annular fluidized bed, the amount of solids discharged from the reactor can also be passed on for further processing or treatment, for example product cooling in a suspension heat exchanger.

10
15

In a development of the idea of the invention, it is provided that, after passing through the separator and possibly a first cooling stage, such as a suspension heat exchanger, the solids removed from the reactor are supplied to a further cooling stage, which has an injection cooler fluidized with air and/or a fluidized bed cooler fluidized with air. In this case it is possible for example to cool the solids to below 300°C, in particular to below 200°C, in the injection cooler by injecting water and/or to cool them to the further processing temperature in the fluidized bed coolers by water passed in counter-current through cooling coils. The exhaust gas of the further cooling stage and of the separator of the pre-heating stage is preferably supplied to a further separator, in particular a bag filter, the solids separated in the further separator being supplied to one of the fluidized bed coolers.

20

25

A plant in accordance with the invention, which is in particular suited for performing the method described above, has a reactor constituting a fluidized bed reactor for the heat treatment of solids containing titanium, the reactor having a gas supply system which is formed such that gas flowing through the gas supply system entrains solids from a stationary annular fluidized bed, which at least partly surrounds the gas supply system, into the mixing chamber. Preferably, this gas supply system extends into a mixing chamber. It is, however, also possible to let the gas supply system end below the surface of the annular fluidized bed. The gas is then introduced into the annular fluidized bed for example via lateral apertures, entraining solids from the annular fluidized bed into the mixing chamber due to its flow velocity.

The present invention is directed to a plant for the heat treatment of solids containing titanium comprising:

a first reactor, wherein the first reactor comprises at least one gas supply tube being at least partly surrounded by an annular chamber in which a stationary annular fluidized bed is located;

a mixing chamber located above an upper orifice region of the gas supply tube such that gas flowing through the gas supply tube entrains solids from the stationary annular fluidized bed into the mixing chamber when passing through the upper orifice region of the gas supply tube;

a first solids separator downstream of the first reactor, wherein the first solids separator comprises a solids conduit leading to the stationary annular fluidized bed of the first reactor; and

a second reactor downstream of the first reactor, wherein the second reactor comprises a second downstream solids separator, the exhaust gas of which is passed via a supply conduit into the stationary annular fluidized bed of the first reactor.

11a

In accordance with a preferred aspect of the invention, the gas supply system has a central tube extending upwards substantially vertically from the lower region of the reactor, which is at least partly surrounded by a chamber in which the stationary annular fluidized bed is formed. The annular fluidized bed does not have to be annular, but rather other forms of the annular fluidized bed are also possible, in dependence on the geometry of the central tube and the reactor, as long as the central tube is at least partly surrounded by the annular fluidized bed.

10 Of course, two or more central tubes with different or identical dimensions may also be provided in the reactor. Preferably, however, at least one of the central tubes is arranged approximately centrally with reference to the cross-sectional area of the reactor.

In accordance with a further embodiment of the present invention, the central tube has apertures on its shell surface, for example in the form of slots, so that during the operation of the reactor solids constantly get into the central tube

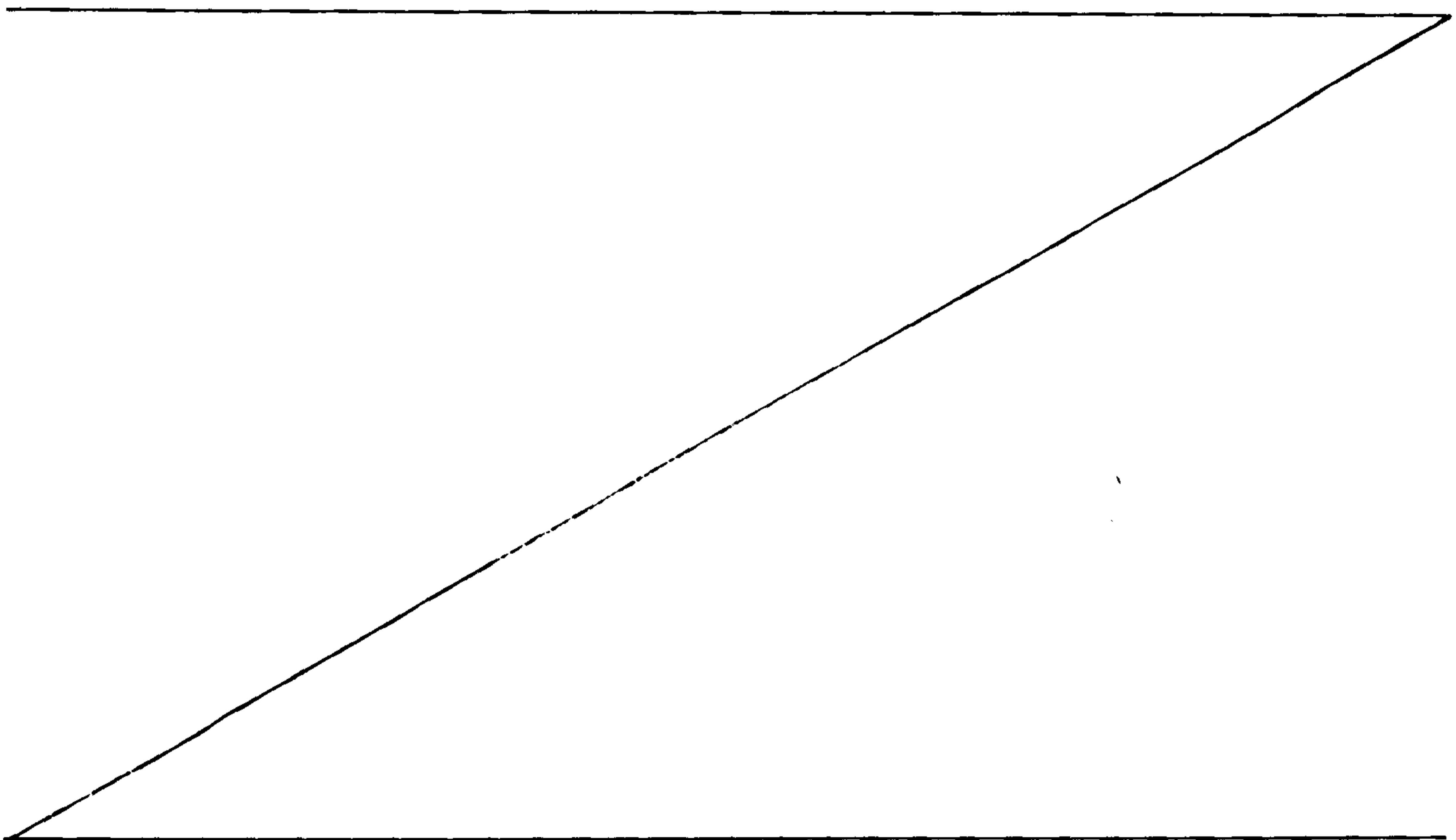

- 12 -

through the apertures and are entrained by the first gas or gas mixture from the central tube into the mixing chamber.

5 Separation of the solids from the gas or gas mixture produced during the heat treatment is made possible before further processing if a separator is provided downstream of the reactor. For this purpose, a cyclone, a hot-gas electrostatic precipitator, a hot-gas cartridge filter or the like can be used for example. In accordance with a preferred embodiment, the solids separator has a solids conduit leading to the annular fluidized bed of the reactor and/or to the annular fluidized
10 bed of a second reactor possibly provided downstream.

To provide for a reliable fluidization of the solids and the formation of a stationary fluidized bed, provided in the annular chamber of the reactor is a gas distributor which divides the chamber into an upper fluidized bed region and a
15 lower gas distributor chamber or wind box. The gas distributor chamber is connected to a supply conduit for preferably largely dust-free and hydrogen-containing fluidizing gas, which may be heated up to achieve the temperatures necessary for the reduction. For magnetic roasting, fuel-containing fluidizing gas may be fed to the reactor. Instead of the gas distributor chamber, a gas distributor
20 composed of tubes may also be used.

If the second reactor for the reduction has a downstream solids separator, the exhaust gas of which is directed via a supply conduit into the central tube of the first reactor, the energy utilization of the plant can be further improved. The often still dust-laden and warm exhaust gas can in this way be used directly in the
25 plant.

A re-processing stage for the exhaust gas is preferably provided downstream of the solids separator of the reactor, so that the reducing gas circulates in the
30 plant.

– 13 –

For adjusting the temperatures necessary for the heat treatment of the solids, such as for example the magnetic roasting, the reactor preferably has a conduit leading to the central tube and/or a supply conduit for in particular gaseous fuel, leading to a lance arrangement which opens out into the annular chamber. Liquid fuels are expediently atomized with a gas in a two-substance nozzle. The atomizing gas at the same time cools the nozzle.

In addition or alternatively, a pre-heating stage in which the solids to be roasted are dried and pre-heated may be provided upstream of the reactor. In order to lower the energy demand of the plant, the heat exchanger, for example a venturi dryer, is in this case connected to the exhaust-gas conduit of the separator provided downstream of the reactor, so that the hot exhaust gases of the reactor are used for pre-heating the solids. Moreover, the exhaust-gas conduit of a cooling stage provided downstream of the reactor for cooling the solids removed from the reactor may be connected to the central tube, so that the heated exhaust gas of the cooling stage is fed in a pre-heated state to the reactor as oxygen-containing gas.

To cool the solids removed from the reactor after roasting to a temperature required for their further processing, the first cooling stage may be provided downstream with further cooling stages, for example injection coolers and/or fluidized bed coolers.

In the annular fluidized bed and/or the mixing chamber of the reactor, means for deflecting the solids and/or fluid flows may be provided in accordance with the invention. It is for instance possible to position an annular weir, whose diameter lies between that of the central tube and that of the reactor wall, in the annular fluidized bed such that the upper edge of the weir protrudes beyond the solids level obtained during operation, whereas the lower edge of the weir is arranged

- 14 -

at a distance from the gas distributor or the like. Thus, solids raining out of the mixing chamber in the vicinity of the reactor wall must first pass by the weir at the lower edge thereof, before they can be entrained by the gas flow of the central tube back into the mixing chamber. In this way, an exchange of solids is enforced in the annular fluidized bed, so that a more uniform retention time of the solids in the annular fluidized bed is obtained.

Developments, advantages and application possibilities of the invention also emerge from the following description of exemplary embodiments and the drawing. All features described and/or illustrated in the drawing form the subject-matter of the invention per se or in any combination, independently of their inclusion in the claims or their back-reference.

Brief Description of the Drawings

15

Fig. 1 shows a process diagram of a method and a plant in accordance with a first embodiment of the present invention,

Fig. 2 shows a detail from Fig. 1 in an enlargement and

20

Fig. 3 shows a process diagram of a method and a plant in accordance with a second exemplary embodiment of the present invention.

Detailed Description of a Preferred Embodiment

25

In the method shown in Figures 1 and 3, which is in particular suited for the heat treatment of solids containing titanium, solids are introduced into a reactor 1 via a supply conduit 2, as can be seen in the enlarged representation of Fig. 2. The reactor 1, which is cylindrical for example, has a central tube 3, which is ar-

- 15 -

ranged approximately coaxially with the longitudinal axis of the reactor and extends substantially vertically upwards from the bottom of the reactor 1.

5 Provided in the region of the bottom of the reactor 1 is an annular gas distributor chamber 4, which is closed off at the top by a gas distributor 5 having apertures. A supply conduit 6 opens out into the gas distributor chamber 4.

10 Arranged in the vertically upper region of the reactor 1, which forms a mixing chamber 7, is a discharge conduit 8, which opens out into a separator 9 formed as a cyclone.

15 If solids are then introduced into the reactor 1 via the supply conduit 2, a layer annularly surrounding the central tube 3, which is referred to as an annular fluidized bed 10, forms on the gas distributor 5. Fluidizing gas introduced into the gas distributor chamber 4 through the supply conduit 6 flows through the gas distributor 5 and fluidizes the annular fluidized bed 10, so that a stationary fluidized bed is formed. The velocity of the gases supplied to the gas distributor chamber 4 is adjusted such that the particle Froude number in the annular fluidized bed 10 is approximately 0.4 for a method in accordance with Fig. 1 or approximately 0.2 for a method in accordance with Fig. 3.

20

By supplying further solids into the annular fluidized bed 10, the level of the solids 11 in the reactor 1 increases to the extent that solids enter the orifice of the central tube 3. At the same time, a gas or gas mixture is introduced into the reactor 1 through the central tube 3. The velocity of the gas supplied to the reactor 1 is preferably adjusted such that the particle Froude number in the central tube 3 is approximately 15 for a method in accordance with Fig. 1 or approximately 12 for a method in accordance with Fig. 3 and in the mixing chamber 7 is approximately 1.4 for a method in accordance with Fig. 1 or 3. Due to these high gas velocities, the gas flowing through the central tube entrains solids from the

25

30

- 16 -

stationary annular fluidized bed 10 into the mixing chamber 7 when passing through the upper orifice region.

5 Due to the banking of the level 11 of the annular fluidized bed 10 as compared to the upper edge of the central tube 3, solids flow over this edge into the central tube 3, whereby an intensively mixed suspension is formed. The upper edge of the central tube 3 may be straight, corrugated or indented or have lateral inlet apertures, for example in the shell region. As a result of the reduction of the flow velocity by the expansion of the gas jet and/or by impingement on one of the
10 reactor walls, the entrained solids quickly lose speed and partly fall back again into the annular fluidized bed 10. The amount of not precipitated solids is discharged from the reactor 1 together with the gas stream via the conduit 8. Between the reactor regions of the stationary annular fluidized bed 10 and the mixing chamber 7 there is thereby obtained a solids circulation which ensures a
15 good heat transfer. Before further processing, the solids discharged via the conduit 8 are separated from the gases or gas mixtures in the cyclone 9.

In the case of the method in accordance with Fig. 1, the solids may be heated under oxidizing conditions in a pre-heating stage 12 before they are introduced
20 into the reactor 1 via the supply conduit 2. In this way, the temperature of the gases fed to the reactor 1 can be kept within the limits technically possible.

In the case of this method, apart from the (first) reactor 1 for the reduction of solids containing titanium, a second reactor 13 is provided for further reduction.
25 Solids are supplied to the second reactor 13 via a supply conduit 14 from the separator 9 provided downstream of the first reactor 1 or directly from the annular fluidized bed 10 of the first reactor 1. For fluidizing the solids, a fluidizing gas, for example containing hydrogen and serving at the same time as a reducing gas, is supplied to the reactor 13 via conduit 15 and a gas distributor 16, so that
30 a stationary fluidized bed with an intensively mixed suspension forms in the re-

- 17 -

actor 13. The second reactor 13 may additionally have a central tube (not represented in Fig. 2), through which for example further reducing gas can be fed to the reactor.

5 Provided downstream of the reactor 13 is a separator 17, for example a cyclone, in which the solids discharged from the reactor 13 are separated from the exhaust gas. The solids are in this case fed to a cooling system 20 via conduit 18 and possibly a further reduction stage 19.

10 The exhaust gases of the reactor 13, separated from the solids in the separator 17, are introduced into the central tube 3 of the reactor 1 via conduit 21. In this way, the heat contained in the exhaust gas can be used for the first reduction stage in the reactor 1.

15 The exhaust gas separated from the solids in the separator 9 provided downstream of the reactor 1 is supplied to a re-processing plant via conduit 22. The exhaust gas is in this case initially cooled in a heat exchanger 23 and fine-cleaned in a further separator 24. After further cooling of the exhaust gases, the water vapour formed during the reduction is condensed in the exhaust gas and
20 drained off through conduit 25. The cleaned exhaust gas is then compressed, possibly with fresh hydrogen-containing gas being admixed via conduit 26, and pre-heated in the heat exchanger 23. In further heating stages 27 and 28, the gas introduced via the central tube 16 into the second reactor 13 and the gas introduced into the first reactor 1 via conduit 6 are heated to the temperatures
25 required for the reduction.

In the case of the method represented in Fig. 3, fine-grained, possibly moist ore with a grain size of less than 500 μm is charged via a screw conveyor into a heat exchanger 29, formed as a venturi dryer, of a first pre-heating stage, in
30 which the material is preferably suspended, dried and heated up by exhaust gas

– 18 –

of the separator 9 provided downstream of the reactor 1. Subsequently, the suspension is conveyed into a cyclone 30, in which the solids are separated from the gas.

5 The ore thus pre-heated is conveyed through the supply conduit 2 into the reactor 1, in which the material is heated up to temperatures of 700 to 950°C. As explained above with reference to Fig. 2, air is supplied as the oxygen-containing fluidizing gas through the conduit 6 and flows via the gas distributor chamber 4 and the gas distributor 5 into the upper part of the annular chamber,
10 where it fluidizes the ore to be heated, thereby forming a stationary fluidized bed 10.

Pre-heated air is constantly supplied to the reactor 1 through the central tube 3 from a downstream first cooling stage, which has a rising conduit 31 to which
15 compressed air is admitted and a downstream cyclone 32 as a separator. It is of advantage in this case that the pre-heated air from the cyclone 32 does not first have to be dedusted. In addition, natural gas is also supplied to the reactor via the central tube 3.

20 The amount of solids which is entrained and discharged through the conduit 8 into the cyclone 9 due to the high gas velocities of the gas flowing through the central tube when it passes can either be returned again into the annular fluidized bed 10 in a dosed manner via the conduit 33, in order in this way to regulate the bed height 11 of the solids in the reactor, or be passed together with the
25 stream of solids removed from the annular fluidized bed 10 through conduit 34 to the rising conduit 31 for cooling.

The required process heat is covered by the combustion of fuel. For this purpose, natural gas is supplied for example to the reactor as fuel, which is introduced via the conduit 35 into the central tube 3 and from there while being
30

- 19 -

5 mixed with the oxygen-containing gas from conduit 36 into the reactor 1. Alternatively or in addition, fuel can also be introduced directly into the annular fluidized bed 10 or the mixing chamber 7 via a corresponding lance arrangement 37. It is alternatively possible to fluidize the annular fluidized bed 10 with natural gas. In this case, natural gas is introduced via the conduit 6, in which case oxygen-containing gas must not get into the conduit 6. To ensure a complete combustion of the fuel, the air supplied to the reactor must have an adequate oxygen content. As an alternative to this, a different oxygen-containing gas may also be introduced into the reactor 1 via a supply conduit.

10

15 Provided downstream of the first cooling stage with the rising conduit 31 and the separator 32 is a further cooling system with three cooling stages, to cool the solids to the temperature necessary for further processing. This cooling system has firstly an injection cooler 38, into which ambient air for fluidizing is blown via conduit 39. At the same time, a cooling medium, such as water, is injected into the injection cooler 38 via conduit 40, in order to cool the solids rapidly. Provided downstream of the injection cooler 38 are two fluidized bed coolers 41 and 42, in which water for example is passed as the cooling medium in counter-current through cooling coils 43, 44 and at the same time ambient air is likewise introduced through conduit 39 as fluidizing air, whereby the product is further cooled.

20

25 The exhaust gas of the cyclone 30 of the pre-heating stage and also the exhaust gases of the cooling stages 38, 41 and 42 of the cooling system are passed via a common conduit 45 to a further separator 46, for example a bag filter. The dust separated therein can be returned to the fluidized bed cooler 42 via a conduit 47.

25

30 The temperature of the solids leaving the reactor 1 can be deliberately varied by a regulating device not represented in the figures. For this purpose, the actual

30

- 20 -

outlet temperature of the solids is measured, for example in the conduit 8, and the supply of fuel into the reactor 1 is controlled in dependence on an adjustable setpoint outlet temperature.

5 The invention will be described below with reference to two examples demonstrating the inventive idea, but not restricting the same.

Example 1 (reduction of ilmenite)

10 In a plant corresponding to Fig. 1, 66 t/h of ilmenite with a temperature of approximately 1000°C and with a grain size of approximately 0.125 mm, containing

51 wt-% TiO₂

40 wt-% Fe₂O₃

15

were supplied to the reactor 1. Furthermore, 93,000 Nm³/h of reducing gas with a temperature of 874°C were supplied to the reactor 1 via conduit 6, the reducing gas having the following composition:

91.7 vol-% H₂,

20

0.4 vol-% H₂O and

7.9 vol-% N₂.

25

In addition, 216,000 Nm³/h of hydrogen-containing exhaust gas with a temperature of approximately 850°C were supplied to the reactor 1 via conduit 21 and the central tube 3 from the separator 17 provided downstream of the second reactor 13. The exhaust gas had in this case the following composition:

90.6 vol-% H₂,

1.4 vol-% H₂O and

30

8.0 vol-% N₂.

- 21 -

A stream of solids from the annular fluidized bed 10 was continuously removed from the first reactor 1 and partly mixed with solids separated from exhaust gas in the separator 9. In this way, approximately 60 t/h of solids containing:

5

56 wt-% TiO₂,
13 wt-% FeO and
21 wt-% Fe

10 were supplied to the second reactor 13. A total of 216,000 Nm³/h of reducing gas with a temperature of 871°C were introduced into the reactor 13 via the supply conduit 15 and via a possibly provided central tube. The reducing gas had in this case the following composition:

15

91.7 vol-% H₂,
0.4 vol-% H₂O and
7.9 vol-% N₂.

Then 58 t/h of solids which had the following composition:

20

57 wt-% TiO₂,
2 wt-% FeO and
30 wt-% Fe

25

were removed from the separator 17 provided downstream of the reactor 13 via conduit 18.

In the separator 9, which is provided downstream of the first reactor 1, 310,000 Nm³/h of exhaust gas with a temperature of 850°C were supplied to the

- 22 -

re-processing plant. The exhaust gas in this case had the following composition:

5 88 vol-% H₂,
 3.9 vol-% H₂O and
 7.8 vol-% N₂.

Under these conditions it was possible for the oxidized ilmenite to be reduced in the first reduction stage in the reactor 1 to 80% metallization and subsequently to be reduced in the second reduction stage in reactor 13 to 97% metallization. At the same time, it was possible to prevent to the greatest extent the formation of M₃O₅ phases, such as for example Ti₂MgO₅, Ti₂MnO₅ or Ti₂FeO₅, which cannot be dissolved, or only with difficulty, in the downstream hydrometallurgical process stages.

15

Example 2 (magnetic roasting of ilmenite)

In a plant corresponding to Fig. 3, 43 t/h of moist ilmenite with a grain size of less than 315 µm were supplied to the venturi dryer 29 via the screw conveyor.

20

After passing through the pre-heating stages 29, 30, the pre-dried ilmenite was introduced into the annular fluidized bed 10 of the reactor 1 via the conduit 2. About 9000 Nm³/h of air were supplied as fluidizing gas to the reactor 1, about 7000 Nm³/h of pre-heated and dust-laden air from the separator 32 of the cooling stage provided downstream of the reactor being introduced via conduit 36 into the central tube 3 and about 2000 Nm³/h of cold air being supplied via the conduit 6 and the wind box (gas distributor chamber) 4 for the fluidizing of the annular fluidized bed 10. At the same time, 580 Nm³/h of natural gas were supplied as fuel to the reactor via the conduit 28 and burnt. The temperature in the reactor 1 was between 700 and 950°C. The hot gas produced during the com-

30

- 23 -

bustion heated the ilmenite introduced and partial roasting of the ilmenite was achieved by the high retention time in the reactor 1 with excess of oxygen.

5 The roasted ilmenite was withdrawn from the annular fluidized bed 10 and supplied via conduit 34 to the first cooling stage 31, in which the product was cooled with 7000 Nm³/h of air and subsequently separated from the exhaust gas in the separator 32.

10 A further 12,000 Nm³/h of fluidizing air were distributed in approximately equal parts among the three cooling stages 38, 41, 42 of the downstream cooling system. The pre-cooled ilmenite was firstly fluidized in the injection cooler 38 and cooled to below 200°C by injection of around 6 m³/h of water through the conduit 40. The final cooling of the product then took place in the two chambers 41 and 42 of the fluidized bed coolers, cooling water being supplied in counter-
15 current to the banks of cooling tubes 43, 44 installed in the chambers.

In this way it was possible for the ilmenite to be magnetically roasted, i.e. at least partly oxidized.

- 24 -

List of Reference Numerals:

1	reactor	21,22	conduit
2	supply conduit for solids	23	heat exchanger
3	gas supply tube (central tube)	24	separator
4	gas distributor chamber	25,26	conduit
5	gas distributor	27,28	heating stage
6	supply conduit for fluidizing gas	29	venturi dryer
7	mixing chamber	30	cyclone
8	conduit	31	rising conduit
9	separator (cyclone)	32	cyclone
10	(stationary) annular fluidized bed	33-36	conduit
11	level of the annular fluidized bed	37	lance arrangement
12	pre-heating stage	38	injection cooler
13	(second) reactor	39,40	conduit
14,15	supply conduit	41,42	fluidized bed cooler
16	gas distributor	43,44	bank of cooling tubes
17	separator	45	conduit
18	conduit	46	bag filter
19	reduction stage	47	conduit
20	cooling system		

WHAT IS CLAIMED IS:

1. A method for the heat treatment of solids containing titanium, in which fine-grained solids are treated at a temperature of 700 to approximately 950°C in a fluidized bed reactor (1), characterized in that a first gas or gas mixture is introduced from below through at least one gas supply tube (3) into a mixing chamber (7) of the reactor (1), the gas supply tube (3) being at least partly surrounded by a stationary annular fluidized bed (10) which is fluidized by supplying fluidizing gas, and that the gas velocities of the first gas or gas mixture as well as of the fluidizing gas for the stationary annular fluidized bed (10) are adjusted such that
10 the stationary particle Froude numbers in the gas supply tube (3) are between 1 and 100, in the stationary annular fluidized bed (10) between 0.02 and 2 and in the mixing chamber (7) between 0.3 and 30.
2. The method as claimed in claim 1, characterized in that the particle Froude number in the gas supply tube (3) is between 1.15 and 20.
3. The method as claimed in claim 2, wherein the particle Froude number in the gas supply tube (3) is between 12 and 15.
4. The method as claimed in any one of claims 1 to 3, characterized in that the particle Froude number in the stationary annular fluidized bed (10) is between 0.115 and 1.15.
- 20 5. The method as claimed in claim 4, wherein the particle Froude number in the stationary annular fluidized bed (10) is between 0.2 to 0.4.
6. The method as claimed in any one of the claims 1 to 5, characterized in that the particle Froude number in the mixing chamber (7) is between 0.37 and 3.7.

7. The method as claimed in claim 6, wherein the particle Froude number in the mixing chamber is 1.4.
8. The method as claimed in any one of claims 1 to 7, characterized in that the bed height of solids in the reactor (1) is adjusted such that the stationary annular fluidized bed (10) extends at least partly beyond an upper orifice end of the gas supply tube (3) and that solids are constantly introduced into the first gas or gas mixture and entrained by the gas stream to the mixing chamber (7) located above the orifice region of the gas supply tube (3).
9. The method as claimed in any one of claims 1 to 8, characterized in that the
10 first gas or gas mixture is passed through the gas supply tube (3) provided with apertures on its shell surface.
10. The method as claimed in claim 9, wherein the apertures are in the form of slots.
11. The method as claimed in any one of claims 1 to 10, characterized in that ilmenite is used as the starting material and is reduced in the reactor (1).
12. The method as claimed in any one of claims 1 to 11, characterized in that hydrogen-containing gas is supplied to the reactor (1).
13. The method as claimed in claim 12, characterized in that the hydrogen-containing gas has a hydrogen content of 75 to 100% and is introduced into the
20 reactor (1) through the gas supply tube (3) and/or into the stationary annular fluidized bed (10).
14. The method as claimed in claim 13, wherein the hydrogen content is from 85 to 95%.

15. The method as claimed in any one of claims 12 to 14, characterized in that the hydrogen-containing gas contains between 0 and 5% of water vapour and between 5 and 10% of nitrogen.
16. The method as claimed in claim 15, wherein the water vapour is between 0.3 and 4.0%.
17. The method as claimed in claim 15 or 16, wherein the nitrogen is between 7 and 8%.
18. The method as claimed in any one of claims 12 to 17, characterized in that the hydrogen-containing gas is introduced into the reactor (1) with a temperature of
10 between 820 and 900°C.
19. The method as claimed in claim 18, wherein the temperature is between 840 and 880°C.
20. The method as claimed in any one of claims 1 to 19, characterized in that at least part of the exhaust gas of a second reactor (13), provided downstream of the reactor (1), is passed through the gas supply tube (3) into the reactor (1).
21. The method as claimed in claim 20, characterized in that the amount of iron contained in the solids is reduced in the reactor (1) to at least 70%.
22. The method as claimed in claim 21, wherein the amount of iron is reduced to 80%.
- 20 23. The method as claimed in any one of claims 20 to 22, characterized in that the amount of iron contained in the solids is reduced in the second reactor (13) to at least 90%.

24. The method as claimed in claim 23, wherein the amount of iron is reduced to 97%.

25. The method as claimed in any one of claims 20 to 24, characterized in that, following re-processing by separation of the solids, cooling and separation of the water, at least part of the exhaust gas of the reactor (1) is heated up and supplied to the stationary annular fluidized bed (10) of the reactor (1) through a conduit (6).

26. The method as claimed in any one of claims 20 to 25, characterized in that a cooling stage (20) for the solids is provided downstream of the second reactor (13).

10 27. The method as claimed in any one of claims 20 to 26, characterized in that a separating stage (9, 17) for separating the solids from the exhaust gas is respectively provided downstream of the reactor (1) and of the second reactor (13), and that the separated solids are at least partly supplied to the reactor and second reactor.

28. The method as claimed in any one of claims 1 to 10, characterized in that ilmenite is used as the starting material and is magnetically roasted in the reactor (1).

29. The method as claimed in claim 28, characterized in that fuel which, by its combustion with an oxygen-containing gas, generates at least part of the amount of heat required for the thermal treatment is supplied to the reactor (1).

20 30. The method as claimed in claims 28 or 29, characterized in that gaseous fuel is introduced through lances (37) into the mixing chamber (7), the stationary annular fluidized bed (10) and/or through a conduit (35) into the gas supply tube (3) and from there together with oxygen-containing gas into the reactor (1), and that compressed ambient air or pre-heated air is introduced as fluidizing gas via a

supply conduit (6) and a gas distributor (5) into the stationary annular fluidized bed (10) of the reactor (1).

31. The method as claimed in claim 30, wherein the gaseous fuel is natural gas.

32. The method as claimed in any one of claims 28 to 31, characterized in that air, which is pre-heated and optionally dust-laden, is introduced into the reactor (1) through the gas supply tube (3).

33. The method as claimed in any one of claims 28 to 32, characterized in that solids are removed from the reactor (1) from the stationary annular fluidized bed (10) and supplied to a cooling stage (31, 32), in which the solids are subjected to a
10 cooling medium and to a downstream separator (32).

34. The method as claimed in claim 33, wherein the cooling medium is air.

35. The method as claimed in claim 33 or 34, wherein the downstream separator (32) is a cyclone.

36. The method as claimed in any one of claims 28 to 35, characterized in that at least part of the exhaust gas of the reactor (1) is largely separated from solids in a second downstream separator (9), and supplied to a pre-heating stage upstream of the reactor (1) with a dryer (29) and an upstream separator (30) for drying and pre-heating the solids to be supplied to the reactor (1).

37. The method as claimed in claim 36, wherein the second downstream
20 separator is a cyclone.

38. The method as claimed in claim 37, wherein the upstream separator (30) is a cyclone.

39. The method as claimed in any one of claims 36 to 38, characterized in that the solids separated from the exhaust gas in the downstream separator (9) are supplied to the stationary annular fluidized bed (10) and/or a suspension heat exchanger (31).

40. The method as claimed in any one of claims 36 to 39, characterized in that the solids removed from the reactor (1) are supplied after a first cooling stage (31) or directly to a further cooling stage, which has a fluidized injection cooler (38) and/or fluidized bed coolers (41, 42).

10 41. The method as claimed in claim 25, characterized in that the solids are cooled to below 300°C in a fluidized injection cooler (38) by injecting water and are cooled to a further processing temperature in fluidized bed coolers (41, 42) by water passed in counter-current through cooling coils.

42. The method as claimed in claim 41, wherein the solids are cooled to below 200°C.

43. The method as claimed in claim 40, characterized in that the exhaust gas of the further cooling stage (38, 41, 42) and of the upstream separator (30) of the pre-heating stage is supplied to a further separator (46) and that the solids separated in the further separator (46) are supplied to one of the fluidized bed coolers (41, 42).

20 44. The method as claimed in claim 43, wherein the further separator (46) is a bag filter.

45. A plant for performing the method as defined in claim 1, for the heat treatment of solids containing titanium, the plant comprising:

a first reactor, wherein the first reactor comprises the at least one gas supply tube being at least partly surrounded by the annular chamber in which the stationary annular fluidized bed is located;

the mixing chamber located above an upper orifice region of the gas supply tube such that gas flowing through the gas supply tube entrains solids from the stationary annular fluidized bed into the mixing chamber when passing through the upper orifice region of the gas supply tube;

a first solids separator downstream of the first reactor, wherein the first solids separator comprises a solids conduit leading to the stationary annular fluidized bed of the first reactor; and

10 a second reactor downstream of the first reactor, wherein the second reactor comprises a second downstream solids separator, an exhaust gas of which is passed via a supply conduit into the stationary annular fluidized bed of the first reactor.

46. The plant as claimed in claim 45, comprising a reprocessing stage downstream of the first solids separator for treating the exhaust gas.

47. The plant as claimed in claim 45 or 46, characterized in that the at least one gas supply tube (3) extends upwards substantially vertically from a lower region of the first reactor (1) into the mixing chamber (7).

48. The plant as claimed in any one of claims 45 to 47, characterized in that the gas supply tube (3) is arranged approximately centrally with reference to the cross-sectional area of the first reactor (1).

20 49. The plant as claimed in any one of claims 45 to 48, characterized in that a gas distributor (5) is provided in the annular chamber of the first reactor (1), the gas distributor (5) dividing the annular chamber into an upper fluidized bed region (10) and a lower gas distributor chamber (4), and that the lower gas distributor chamber (4) is connected to a first supply conduit (6).

50. The plant as claimed in claim 49, wherein the first supply conduit (6) supplies heated-up hydrogen-containing or fuel-containing fluidizing gas.

51. The plant as claimed in any one of claims 45 to 50, characterized in that the first reactor (1) has a conduit (35) leading to the gas supply tube (3) and/or to a second supply conduit for leading to a lance arrangement (37) which opens out into the stationary annular fluidized bed (10).

52. The plant as claimed in claim 51, wherein the second supply conduit supplies gaseous fuel.

10 53. The plant as claimed in any one of claims 45 to 49, comprising a pre-heating stage configured to heat the solids disposed upstream of the first reactor, the pre-heating stage including a dryer which is connected to an exhaust-gas conduit of the first solids separator, and comprising a cooling stage configured to cool the solids disposed downstream of the first reactor and comprising a second exhaust-gas conduit connected to the gas supply tube.

54. The plant as claimed in claim 53, characterized in that the cooling stage is provided downstream of the first reactor.

Fig. 2

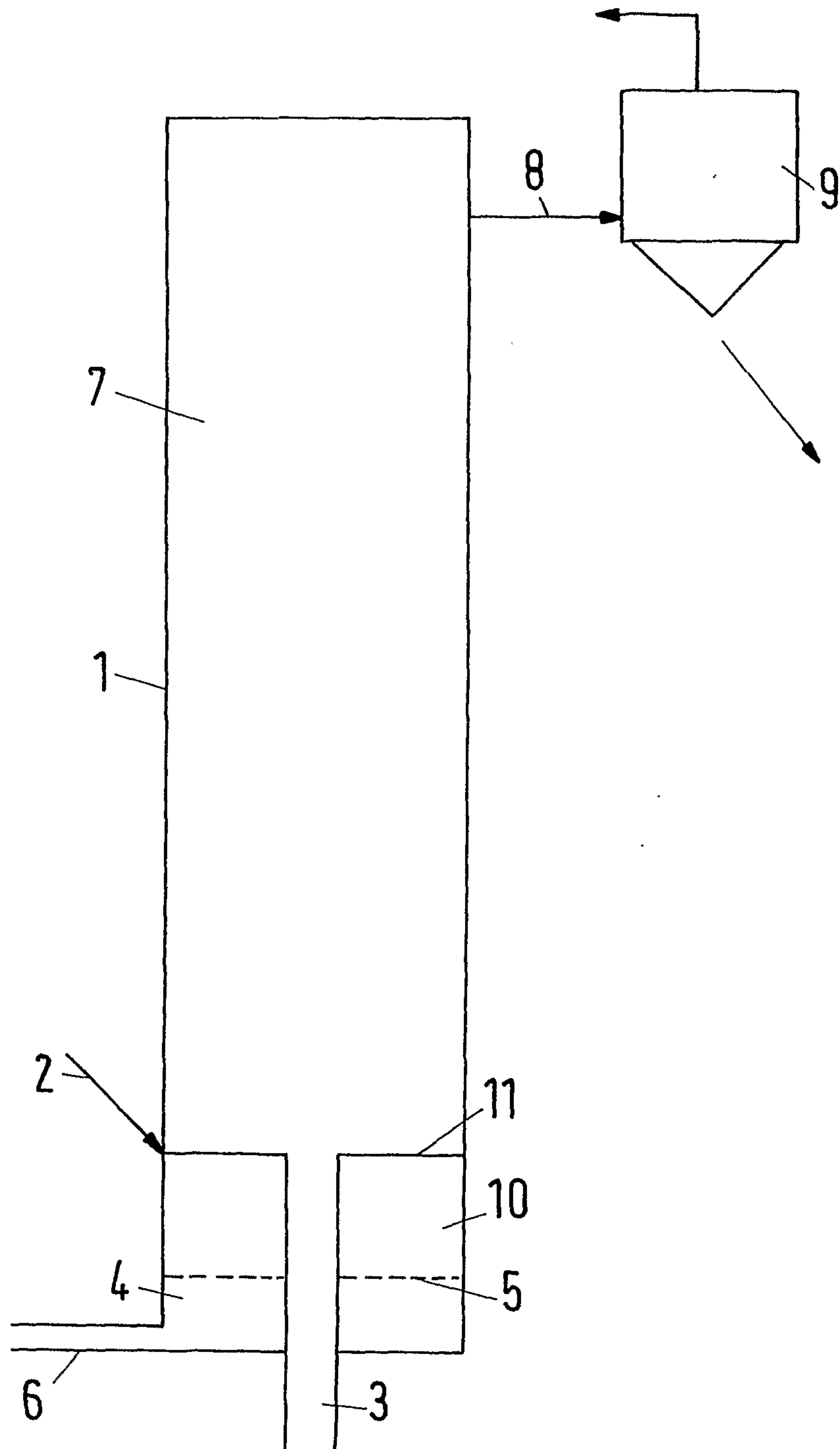

Fig.3

