

(19) World Intellectual Property Organization
International Bureau



(43) International Publication Date
4 January 2001 (04.01.2001)

PCT

(10) International Publication Number
WO 01/01699 A1

(51) International Patent Classification⁶: H04N 7/50, 7/44

(21) International Application Number: PCT/US99/14545

(22) International Filing Date: 28 June 1999 (28.06.1999)

(25) Filing Language: English

(26) Publication Language: English

(71) Applicant (for all designated States except US): **INDEX SYSTEMS, INC.** [US/US]; West Tower - 7th floor, 9100 Wilshire Boulevard, Beverly Hills, CA 90212 (US).

(72) Inventors; and

(75) Inventors/Applicants (for US only): **MACRAE, Douglas, B.** [US/US]; 23 Cart Path Road, Weston, MA 02493 (US). **WESTBERG, Thomas, E.** [US/US]; 4 Puffer Lane, Sudbury, MA 01776 (US).

(74) Agent: **RAHN, LeRoy, T.**; Christie, Parker & Hale, LLP, P.O. Box 7068, Pasadena, CA 91109-7068 (US).

(81) Designated States (*national*): AE, AL, AM, AT, AU, AZ, BA, BB, BG, BR, BY, CA, CH, CN, CU, CZ, DE, DK, EE, ES, FI, GB, GD, GE, GH, GM, HR, HU, ID, IL, IN, IS, JP, KE, KG, KP, KR, KZ, LC, LK, LR, LS, LT, LU, LV, MD, MG, MK, MN, MW, MX, NO, NZ, PL, PT, RO, RU, SD, SE, SG, SI, SK, SL, TJ, TM, TR, TT, UA, UG, US, UZ, VN, YU, ZA, ZW.

(84) Designated States (*regional*): ARIPO patent (GH, GM, KE, LS, MW, SD, SL, SZ, UG, ZW), Eurasian patent (AM, AZ, BY, KG, KZ, MD, RU, TJ, TM), European patent (AT, BE, CH, CY, DE, DK, ES, FI, FR, GB, GR, IE, IT, LU, MC, NL, PT, SE), OAPI patent (BF, BJ, CF, CG, CI, CM, GA, GN, GW, ML, MR, NE, SN, TD, TG).

Published:
— With international search report.

For two-letter codes and other abbreviations, refer to the "Guidance Notes on Codes and Abbreviations" appearing at the beginning of each regular issue of the PCT Gazette.

(54) Title: TELEVISION PROGRAM GUIDE

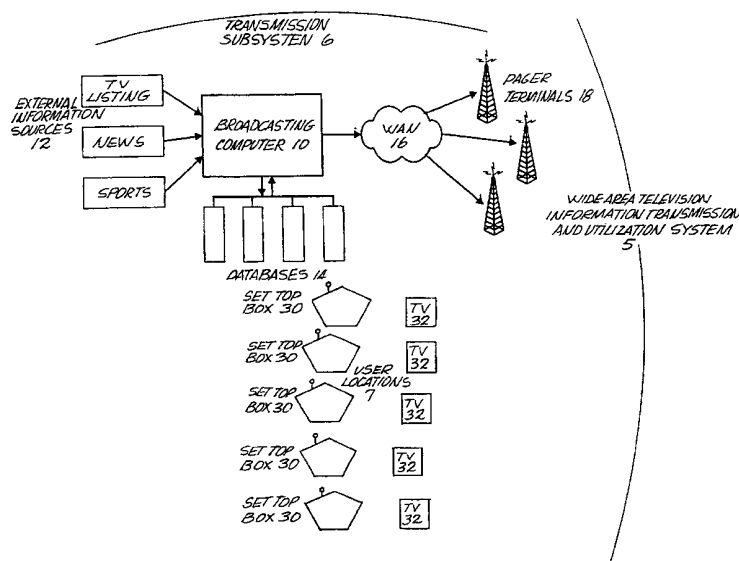

(57) Abstract: A television program schedule guide system in which data is transmitted via pager frequencies (18) to settop boxes (30). A television program schedule guide in which the scores of ongoing sporting events are displayed (fig. 19).



WO 01/01699 A1

1

TELEVISION PROGRAM GUIDE

5 FIELD OF THE INVENTION

This invention relates to a system and method for controlling the broadcast and recording of television programs and for distributing information to be displayed on a television screen.

BACKGROUND OF THE INVENTION

10 There are many known systems for controlling the operation of a television and a video recorder and for providing information on a television screen. One of the primary types of information that is displayed to viewers is programming information which may include current program information as well as future program information. Viewers often have a need to access current and future schedule information and often that requires locating an appropriate television directory in either a newspaper or weekly magazine.

15 For many years, users have also encountered significant difficulties in programming video recorders. In recent years systems have been developed which simplify the recording process so that it is easier for a user to program. These systems (for example, the VCR+ system), however, require that the user locate program listings in some other source before he or she can program the VCR to record. If a program listing includes code information (termed "plus codes"), the user
20 can use depress keys on a VCR+ infrared remote control device in a pattern determined by the code information to, in turn, program the VCR. The code information identifies channel, broadcast time and duration for a program that the user wishes to record. This must be done for each program to be recorded, and for each, for example, weekly episode.

25 In many known systems which provide programming information to the user, the programming information is loaded at some periodic basis. Television stations, however, often change the programs that will be aired and there is no way for updating such systems of last minute programming changes. Therefore, if a user views programming information on his television and either sets a recorder to record the program or makes plans to be able to watch a program at a certain time and the station changes that programming information, either the
30 wrong program will be recorded or the user would not be able to watch the program that he desired to watch.

35 In another system, called "Starsight", program information may be broadcast by a television broadcasting station on an interleaved basis while it is broadcasting television programs, in particular during a portion of the television signal termed the "vertical blanking interval." When the information is displayed, a program may be selected for viewing or recording by moving a highlight cursor to a program title on the display and depressing a button on a remote control device. However, it is not economical to guarantee that the information is available in the vertical blanking interval of every transmitted channel, so this system generally

1 cannot receive information updates while channels other than those carrying the information
signal are being viewed.

SUMMARY OF THE INVENTION

5 The invention provides a new and improved system and method for controlling the
broadcast and recording of television programs and for distributing information to be displayed
on a television screen.

In brief summary, the new system includes a central broadcasting computer which
receives television schedule and episode, news, sports and other information from various
sources. The central broadcasting computer transmits this information over a wide area network
10 to a multiplicity of radio transmitters covering a wide area, such as the entire continental United
States. These transmitters transmit the information to individual set-top boxes in homes and
businesses using a reserved nationwide pager frequency. Each set-top box includes a CPU and
a memory means. The broadcast information is processed by the CPU and stored in the memory
means until accessed by the user.

15 Each set-top box is configured so that the user may use a single, ergonomically designed
user control device, such as an IR remote control to control his television and external devices
(such as VCRs, video disk players, cable decoders and antennas). Using the user control device,
the user can also cause the television to display the broadcast information in various easy-to-
understand formats. Among these display screens are grids of television and cable programming
20 organized by channel and time, news headlines and supporting information, and up-to-date sports
scores and highlights. By selecting programs or other options from these screens, the user may
cause the television to change channels to the desired program or may program the VCR to
record certain programs. By selecting other menu options, the user may also cause the television
to automatically be muted or switch to another channel during commercial breaks, and to skip
25 commercial breaks when recording programs.

In a preferred embodiment, the RF transmitters broadcast information using the
nationwide pager bandwidth around 931 MHz. Information is encoded using any of a number
of well-known transmission protocols, such as the POCSAG protocol or the Motorola FLEX
protocol. The system includes a unique method of reducing noise and interpreting broadcast data
30 in this format.

The attainment of the foregoing and related objects, advantages and features of the
invention should be more readily apparent to those skilled in the art after review of the following
detailed description of the invention, which should be read in conjunction with the
accompanying drawings.

35 DESCRIPTION OF THE DRAWINGS

This invention is pointed out with particularity in the appended claims. The above and
further advantages of this invention may be better understood by referring to the following
description taken in conjunction with the accompanying drawings, in which:

1 FIG. 1 is a block diagram of the wide area system for transmitting broadcasting information of the present invention;

FIG. 2 is a block diagram of a pager terminal used in the system shown in FIG. 1;

5 FIG. 3 is a block diagram of the components of a set-top box used in the system and process of the present invention for providing information and for controlling the operation of a television and associated external devices;

FIG. 4 is a block circuit diagram of the RF receiver used in the set-box shown in FIG. 3;

FIG. 5a is a block circuit diagram of the data deserialization module 74 shown in FIG. 4;

10 FIG. 5b is a block circuit diagram of an alternate embodiment of the comparator operation used in the data deserialization module shown in FIG. 5a;

FIG. 6 is a block circuit diagram of the bit sampling module shown in FIG. 5a;

FIGs. 7a and 7b are representative signal samples processed by the bit sampling module of FIG. 5a;

15 FIG. 8 is another signal representation which is processed by the bit sampling module shown in FIG. 5a;

FIG. 9 is a flow chart of the operation of the CPU of the present invention which provides task scheduling, and communications facilities for the system;

FIG. 10 is a functional diagram of the information processed by the system of the present invention;

20 FIG. 11 is a data representation of a data record transmitted by the system of the present invention;

FIG. 12 is a diagram illustrating the data flow in a particular application in the system and method of the present invention;

25 FIG. 13 is a block diagram showing the relationship of various functional components of the system and process of the present invention used for displaying information on a television screen;

FIG. 14 is a flow chart showing the steps associated with a memory request made by the system and process of the present invention;

30 FIG. 15 is a functional diagram of the remote control used in the system of the present invention;

FIG. 16 is a representation of the main screen display generated by the system of the present invention;

FIG. 17 is a representation of a Navigation Screen generated by the system of the present invention;

35 FIG. 18 is a representation of a Program Grid screen generated by the system of the present invention;

FIG. 19 is a representation of a Sports Ticker screen generated by the system of the present invention;

1 FIG. 20 is a representation of a News Screen generated by the system of the present invention;

FIG. 21 is a flowchart of the steps of the automatic recording process utilized by the system of the present invention;

5 FIG. 22 is a flowchart of the steps utilized by the system of the present invention for implementing the "While recording" commercial avoidance feature;

FIG. 23 is a flowchart of the steps utilized by the system of the present invention for implementing the "While Viewing" commercial avoidance feature;

10 FIG. 24 is a block diagram of the components of the commercial avoidance systems of the present invention;

FIG. 25 is a diagram of the commercial monitoring center as shown in FIG. 24;

FIG. 26 is a diagram of an alternate embodiment of the commercial monitoring center shown in FIG. 25.

15 FIG. 27 is a diagram of the components utilized by the system of the present invention to process remotely issued commands.

DETAILED DESCRIPTION OF THE INVENTION

A. Transmission Network.

20 FIG. 1 depicts a wide area television information transmission and utilization system 5 constructed in accordance with the invention. With reference to FIG. 1, system 5 includes an information transmission subsystem 6 which transmits television scheduling and other information as described below to a plurality of user locations 7. Each user location 7 includes a conventional television receiver, and may include a conventional video cassette recorder (VCR), and a user device that receives the television scheduling and other information and uses this information, along with inputs provided by a user, to control the television receiver and
25 VCR, as also described below.

30 As shown in FIG. 1, the information transmission subsystem 6 includes a central information broadcasting computer 10, which receives television schedule information, television episode, news, sports, weather and other information (generally identified as "miscellaneous information"), as well as certain command and system information used by the system (generally identified as "system information") from a variety of external information sources 12, including third party vendors, other parts of the subsystem 7, and internal databases. Broadcasting computer 10 stores this scheduling, miscellaneous and system information in its own databases 14 and periodically transmits it electronically (in the manner described below) over wide area network ("WAN") 16 to a plurality of pager terminals 18. In a preferred
35 embodiment, wide area network 16 is a conventional commercial frame relay digital data transmission network which transmits data using the conventional TCP/IP communications protocol.

1 Referring now to Fig. 2, each pager terminal 18 includes a computer 20 connected to the
WAN 16. Computer 20 is connected to converter 22, which converts the information received
from WAN 16, which is received in conventional digital form, into radio frequency (RF) signals
suitable for radio transmission. Converter 22 is connected to a high-power RF transmitter 24
5 which broadcasts the information from pager terminal 18 in the form of analog radio pager
signals in the 931 MHz frequency band, which is the frequency band designated for pager use
by the Federal Communications Commission. In the preferred embodiment, over one hundred
pager terminals are used to cover the continental United States. The information sent to each
pager terminal, in particular the scheduling information, is customized to reflect accurate data
10 (program listings, times, etc.) for the geographic region covered by that terminal. The broadcast
computer 10 preferably transmits the scheduling, miscellaneous and system information to the
pager terminals 18, and the pager terminals 18 preferably broadcasts the information to the user
locations 7, during the night, when there is low usage of the pager frequency band. The pager
terminals 18 broadcast the information using any of a number of well-known paging transmission
15 protocols, including POCSAG or the Motorola FLEX protocol.

B. User Location 7

Referring again to FIG. 1, as noted above the information transmission subsystem 6,
through the pager terminals 18, broadcasts the scheduling, miscellaneous and system information
to user locations 7. Each user location 7 includes a user device, identified herein as a set-top box
20 30, a conventional television receiver 32, and may also include a conventional VCR (not shown).
The set-top box 30 receives the scheduling, miscellaneous and system information, and uses the
scheduling and miscellaneous information, in particular, to generate information displays which
it provides to the television receiver 32 at the user location 7. In addition, by means of a user
control device 50 (see FIG. 3), such as a remote control device, the user may provide user
25 information to control the set-top box 30 to, in turn, control the television receiver 32, to, for
example, to change channels, display programs at their scheduled times, and also to enable the
VCR to facilitate recording of certain programs. For example, the set-top box 30 will receive and
store user information relating to displaying certain programs which are broadcast at certain
times, and, at the appropriate times will generate appropriate infrared control signals which are
30 received by the television receiver's remote control infrared detector to enable the television to
turn itself on (if it is not already on), switch to the appropriate channel and display the program.
At the end of the program, the set-top box 30 may enable the television receiver 32 to switch to
another program, or a user has enabled that to occur, to remain on at the same channel, or to
switch itself off. In addition, the set-top box 30 will receive and store user information relating
35 to recording of certain programs which are broadcast at certain times, and will generate the
appropriate infrared control signals which are received by the VCR's remote control infrared
detector to program the VCR to record. The set-top box 30 may also enable the VCR to play the
recording over the television receiver 32 at a selected time.

1 FIG. 3 depicts a functional block diagram of a set-top box 30 useful in a user location 7.
With reference to FIG. 3, each set-top box 30 includes an RF receiver 34 which is tuned to
receive scheduling, miscellaneous and system information in the 931 MHz band. RF receiver 34,
which in one embodiment comprises a conventional receiver used in conventional paging
5 devices, converts this scheduling, miscellaneous and system information from analog to digital
form and supplies the scheduling and system information in digital form via bus 38 to a central
processing unit ("CPU") 36 included in set-top box 30. In a preferred embodiment, CPU 36 is
a standard 16-bit microprocessor which, in one embodiment, comprises a microprocessor
selected from the Motorola MC 68000 microprocessor family. CPU 36 processes the digital
10 scheduling and system information and stores it in a memory 38, which in one embodiment
comprises a battery-backed random access memory implemented in conventional random access
memory chips. In addition, the set-top box 30 includes an EEPROM 40 which stores device
information such as a serial number, subscription controls and certain setup information provided
during setup of the box 30 as described below. The set-top box 30 also includes a read-only
15 memory ("ROM") 42 which contains the program for controlling CPU 36. In one embodiment,
ROM 42 provides 8-bit words, and a latch and state machine 44 enables the ROM 42 to emulate
a 16-bit device in communications with CPU 36.

 The user control device 50, which in one embodiment is a battery-powered infrared
remote control device ('IR remote') produces a low-powered, wide-angle infrared beam 52 which
20 is modulated in response to inputs provided by a user to supply user information, in the form of
user commands, to the set-top box 30. Beam 52 is detected by an IR decoder 54 included in set-
top box 30 and the received infrared signal is converted into digital signals which are processed
by CPU 36.

 An RF switch 58 is provided to enable the set-top box 30 to generate RF signals which
25 are displayed by the television receiver 32. The RF signals will provide a video display by the
television receiver 32 of scheduling and miscellaneous information provided by the information
transmission subsystem 6, thereby enabling the system 5 to display the information to the user.
The RF switch is connected to receive signals from set-top box 30 by a cable 56 and from an
external device 64 (which may be the VCR, a video disc player, a cable decoder or television
30 antenna), and to provide signals via a coaxial cable 66 to the television 32. If the set-top box 30
is not providing an RF signal to RF switch 58, then RF switch 58 will pass signals provided by
the external device 64 to television 32. On the other hand, if the set-top box 30 is providing an
RF signal to the RF switch 58, then the RF switch 58 will block any signal being provided from
external source 64 and will pass the signal provided by set-top box 30 to television receiver 32.
35 When the set-top box 30 is providing RF signals for the television receiver 32 through RF switch
58, it also will generate appropriate infrared control signals which are received by the television
receiver's remote control infrared detector to enable the television to switch to an appropriate
channel to display the RF signals which it (the set-top box 30) generated.

1 As noted above, the set-top box 30 can also control the television receiver 32 and the
VCR, as well as any other external devices 64, by means of an infrared control signal. The
infrared control signal is provided by an infrared output terminal ("IR output") 60. IR output 60
5 produces infrared signals at a range of frequencies, duty cycles and bit-cell times, based on
commands from CPU 36, to emulate most commercially available consumer remote controls,
as described below.

In one embodiment, the system 5 operates as follows: Throughout the day and night, the
information transmission subsystem 6 transmits, and the RF receiver 34 of set-top box 30
receives updated scheduling, miscellaneous and system information and stores it in the memory
10 38. While television 32 is on, the user may issue commands directly to set-top box 30 using user
control device 50. Certain commands will cause set-top box 30 to, through the RF switch, display
scheduling and miscellaneous information on television receiver 32. While scheduling and
miscellaneous information is being displayed on television 32, signals and programming from
external device 64 are blocked by RF switch 58. When scheduling and system information is
15 being displayed on television 32, the set-top box 30 is said to be in "Display Mode." Using user
control device 50, the user may select certain scheduling and system information being displayed
on television 32. Based on the user's selections, set-top box 30, by means of IR output 60, may
send channel tuning or program playback or recording commands to television 32 or external
device 64 or store such commands in the memory 38 and send them at a later time. In an
20 alternate "TV mode," the user may view broadcast or recorded programming on his television
using the user control device 50 to control the external device 64 supplying such programming.

C. RF Receiver 34, Data Deserialization.

HG. 4 depicts a functional block diagram of an RF receiver 34 useful in the set-top box
30. As noted above, the RF receiver 34 receives the scheduling, miscellaneous and system
25 information broadcast by the information transmission subsystem 6. With reference to Fig. 4, in
one embodiment the RF receiver 34 includes a tunable RF receiver 70 which is tunable within
a range of approximately two MHz around 931 MI-Iz. This frequency range was chosen because
it corresponds with the frequency used by national and local pager networks. Tunable RF
receiver 70 is also connected to a received signal strength indicator ("RSSI") 80, which is
30 connected to CPU 36. RSSI 80 determines the relative strength of the signal being received by
tunable RF receiver 70 and provides this data to CPU 36. This relative signal strength data
enables CPU 36 to assist the user with the placement of set-top box 30 during installation, to
enable the user to locate the set-top box 30 in a location at which it can receive a signal from
information transmission subsystem 6 of a suitable signal strength, as described below.

35 Tunable RF receiver 70 is also connected to a demodulator 72, which converts the analog
signal received by tunable RF receiver 70 into either an unblocked two or four-level analog
signal, depending on the paging protocol being used by the system. In one embodiment, in which
the information transmission subsystem 6 may broadcast information in either the POCSAG or

1 the FLEX transmission protocol, the demodulator 72 initially attempts to decode the information
 on the assumption that the information transmission subsystem 6 had used the POCSAG
 protocol. If the demodulator 72 determines that it is unable to identify suitable code words in the
 broadcast information, it attempts to decode the information on the assumption that the
 5 information transmission subsystem 6 had used the FLEX protocol, by searching the information
 for possible good FLEX packets. When the demodulator 72 identifies the appropriate protocol,
 it generates an analog signal in response to the receives signal which it provides to a data
 deserialization module 74, which, in turn, converts the analog signal into a digital signal and
 provides this digital signal to CPU 36.

10 It will be appreciated that the data in the information broadcasts received by the set-top
 box are generally in serial form, and the data deserialization module 74 deserializes the data to
 form word parallel data. As shown in Fig. 5a, data deserialization module 74 includes an analog-
 to-digital converter ("A/D converter") 78, which receives analog signals from demodulator 72
 and converts them to digital signals at conventional TTL (transistor-transistor logic) voltage
 15 levels. A/D converter 78 then supplies these digital signals to comparator 82. Comparator 82
 compares each digital signal to one or more threshold values and produces one or more digital
 output signals based on the results of such comparison. In the preferred embodiment shown in
 Fig. 5a, comparator 82 compares the input signal with three threshold values (designated
 Thresholds 1, 2 and 3) to generate two output voltages (designated MSB 86 and LSB 88) in
 20 accordance with the following table:

Input Compared To Threshold			Output Is	
1	2	3	MSB	LSB
Greater	Greater	Greater	1	0
Greater	Greater	Less	1	1
Greater	Less	Less	0	1
Less	Less	Less	0	0

30 The threshold voltages of comparator 82 are set by CPU 36 during set-up by measuring
 input values while the received signal strength is high and gathering statistics on the digital
 values that are generated. The threshold voltages may be adjusted by CPU 36 based on changes
 in the statistics due to temperature or other environmental change which allows the module 74
 to compensate for voltage drift of the demodulator 72 due to such changes. A temperature
 35 measurement device 84 is connected to CPU 36.

In an alternate embodiment of the data deserialization device 74, which is shown in Fig.
 5b, comparator 82 compares the signal with only one threshold value to generate a one-bit output
 signal. This embodiment may be useful primarily in connection with, for example, the Motorola

1 FLEX protocol. The use of one threshold instead of three provides a wider voltage gap between
different signal levels and thus provides greater noise immunity than a three-threshold
embodiment. However, less information is conveyed in the same time period by a signal having
two rather than four possible values.

5 Referring again to the embodiment depicted in Fig. 5a, to eliminate certain noise-related
errors, comparator 82 compares its input signal with the threshold voltage(s) multiple times
during a "bit cell period." A "bit cell period" is a time window in which one unit of scheduling
and system information (comprising, depending on the number of voltage thresholds used by
comparator 82, one or two bits of information) is broadcast by the information transmission
10 subsystem 6. In one embodiment, comparator 82 makes eight voltage comparisons during each
bit cell period. Because the analog signals received by RF receiver 34 contain no embedded
clocking information, CPU 36 must also ensure that the phase of the input signals corresponds
to the bit cell period of comparator 82. The time interval between comparisons is controlled by
clocking signals from a modulo-8 counter 96 which is connected to comparator 82 and CPU 36.
15 For example, in FIG. 7a, an input signal is shown in which the comparisons are in phase with the
input signal, that is, the comparator performs all of the comparisons while the input signal
represents a single data bit. In that case, the comparator 82 is in phase with the input signal. On
the other hand, in Fig. 7b, an input signal is shown in which the data bit transitions during the
bit cell period; that is, the first three comparisons (0, 1 and 2) are for data bit having a low value,
20 and the last five comparisons (3 through 7) are for a data bit having a high value. The system 5
attempts to prevent the situation illustrated by Fig. 7b from occurring during information
broadcast by including in the broadcast signals, at the beginning and end of each of a series of
data segments, a pre-defined sequence of data bits, such as signals representing a series of binary
"zeroes" followed by signals representing a series of binary "ones" which the CPU 36 may use
25 to ensure that its bit cell period is in phase with the transmitted data. If CPU 36 detects a
transition in the middle of a bit cell period, as shown in Fig. 7b, it will increment the modulo-8
counter 96, effectively shifting the sample window of Fig. 7b to the left by one increment. This
process is repeated until the bit cell period roughly corresponds to the beginning and end of the
information segments that are being received.

30 During normal operation, after the CPU 36 has brought the comparator 82 into phase with
the bit cell period of the received signal, radio transmission noise could interfere with the
accurate interpretation of the scheduling, miscellaneous and system information. As shown in
Fig. 8, which illustrates noise in a received signal, six of the eight comparisons made by
comparator 82 during the shown bit cell period result in an output (the MSB-LSB combination)
35 of "00", while two comparisons result in an output of "01." To determine which of these results
should be passed to the next stage of data interpretation, bit sampling modules 90 and 92 are
used. Bit sampling module 90 receives MSB 86 as an input, while bit sampling module 92
receives LSB 88 as an input.

1 The bit sampling modules 90 and 92 determine values for the most and least significant bits, respectively, based on the number of comparisons by the comparator 82 during a bit cell period giving rise to each bit value. That is, if comparisons generated by the comparator 82 during a bit cell period identify zero through three comparisons for the most significant bit indicating the value "one," the bit sampling module 90 will identify the value "zero" for the most significant bit. On the other hand, if four through seven comparisons for the most significant bit indicate the value "one," the bit sampling module 90 will identify the value "one" for the most significant bit. The bit sampling module 92 operates similarly in connection with the least significant bit.

10 More particularly, the logical operation of bit sampling module 90 is illustrated in Fig. 6. Bit sampling module 92 operates in an analogous manner and will not be described in detail. The most significant bit signal from comparator 82 is coupled over line 86 to 3-bit counter 100. Each time the most significant bit signal identifies a "one," counter 100 is incremented by one. A bit counter 108 is incremented each time the comparator 82 provides a new value identification, and so when the value of counter 108 reaches 8 at the end of each bit cell period it generates a reset signal to reset the counter 100. At the end of each bit cell period, prior to the reset of counter 100, a gate array 102 evaluates the status of counter 100. If the value of counter 100 is 000, 001, 010 or 011 (0, 1, 2 or 3), then the value of the most significant bit, as coupled by gate array 102 over output 104, will be "zero." On the other hand, if the value of counter 100 is 100, 101, 110 or 111 (4, 5, 6 or 7), the value of the most significant bit will be "one."

20 In addition, the bit sampling module 90 generates a value identifying the "quality" of the bit sample, in relation to how close the final value of counter 100 corresponds to the "ideal" or "no noise" value of 0 or 7. In one embodiment, gate array 102 accomplishes this by comparing the first two bits of counter 100. If the two bits are different (representing a "noisy" value of 2, 3, 4 or 5), then the gate array 102 sets an "alert" flag 106, which flag may be accessed by other portions of the system. If the two bits are identical (representing a "clean" value of 0, 1, 6 or 7), then the "alert" flag 106 is reset to 0. Alert flag 106 is the output of a D flip flop 109, the data input of which is connected to the output of gate array 102, and the clear input of which is connected to counter 108.

30 Thus, in the example shown in Fig. 8, bit sampling module 90 will count 8 zeros and no ones for the most significant bit for the bit cell period, resulting in a zero output for the most significant bit; and bit sampling module 92 will count 6 zeros and 2 ones, resulting in a zero output for the least significant bit. Because counter 100 of each bit sampling module 90 was not 2, 3, 4 or 5, the alert flag 106 was not set for either bit, indicating a relatively noise free bit.

35 Referring again to Fig. 5a, at the end of each bit cell period, the outputs of bit sampling modules 90 and 92 are each shifted into a respective 16-bit shift register 110 and 112. After 16 such shifts, a modulo-16 counter 114 resets and causes the contents of shift registers 110, 112 to be shifted into respective 16-bit hold registers 120 and 122. This shift causes an interrupt

1 signal to be sent to CPU 36, which enables the CPU 36 to read the data in the hold registers 120
 and 122. In an alternative embodiment of the invention, modulo 16 counter 114 may be
 incremented by CPU 36 to cause the phase of the sample period to correspond with the phase of
 the input data as discussed above with respect to FIGs. 7a and 7b.

5 **D. Video Generation**

The set-top box 30 stores video image data used to define the video image that is
 transmitted to television receiver 32 in its memory 38. The video image data is retrieved from
 the memory 38 in a conventional manner for use in generating the RF signal coupled to the RF
 switch 58.

10 **E. Data Processing.**

System Control Flow. As illustrated by Fig. 9, the CPU 36 runs under the control of a
 commercially available real-time operating kernel (in one embodiment, the Nucleus Plus kernel
 from Accelerated Technologies) which provides task scheduling and communications facilities
 for the system. Information received from the RF input 34 as described above is sent in software
 15 queues to waiting destination processes, while IR commands from the user control device 50 are
 processed by an interrupt-based driver and passed to a global event queue to be received by the
 currently activated application. In addition, some processes, such as those controlling VCR
 recording, are suspended until scheduled events, such as times to start or stop a VCR, occur.

Data De-Interleave. Data transmitted to the system in the Motorola FLEX paging format
 20 is 8-way interleaved for additional noise immunity as follows:

Reg	D 1	D6	DS	D4	D3	D2	D1	D0
0	A0	B0	C0	D0	E0	F0	G0	H0
1	A1	B1	C1	D1	E1	F1	G1	H1
2	A2	B2	C2	D2	E2	F2	G2	H2
3	A3	B3	C3	D3	E3	F3	G3	H3
4	A4	B4	C4	D4	E4	F4	G4	H4
5	A5	B5	C5	D5	E5	F5	G5	H5
6	A6	B6	C6	D6	E6	F6	G6	H6
7	A7	B7	C7	D7	E7	F7	G7	H7

25 Data is received down the columns of the above table beginning with bit A0, followed by
 B0, C0, ..., H0, A1, ..., H31. To de-interleave the data, the CPU 73 has a set of eight registers
 30 which "rotate" their bits ninety degrees. That is, data is loaded into these registers as follows:

1

Reg	data7	data6	data5	data4	data3	data2	data1	data0
0	A0	A1	A2	A3	A4	A5	A6	A7
1	B0	B1	B2	B3	B4	B5	B6	B7
2	C0	C1	C2	C3	C4	C5	C6	C7
3	D0	D1	D2	D3	D4	D5	D6	D7
4	E0	E1	E2	E3	E4	E5	E6	E7
5	F0	F1	F2	F3	F4	F5	F6	F7
6	G0	G1	G2	G3	G4	G5	G6	G7
7	H0	H1	H2	H3	H4	H5	H6	H7

Upon reading by the CPU 36, the data is rotated so that it appears as follows:

15

Word	Bit																														
A	0	1	2	3	4	5	6	7	8	9	10	11	12	13	14	15	16	17	...	31											
B	0	1	2	3	4	5	6	7	8	9	10	11	12	13	14	15	16	17	...	31											
C	0	1	2	3	4	5	6	7	8	9	10	11	12	13	14	15	16	17	...	31											
D	0	1	2	3	4	5	6	7	8	9	10	11	12	13	14	15	16	17	...	31											
E	0	1	2	3	4	5	6	7	8	9	10	11	12	13	14	15	16	17	...	31											
F	0	1	2	3	4	5	6	7	8	9	10	11	12	13	14	15	16	17	...	31											
G	0	1	2	3	4	5	6	7	8	9	10	11	12	13	14	15	16	17	...	31											
H	0	1	2	3	4	5	6	7	8	9	10	11	12	13	14	15	16	17	...	31											

Because the CPU 36 addresses the registers and memory 38 on a byte-by-byte basis, only one byte at a time needs to be rotated using the above method, although a full 256 bits (corresponding to eight 32-bit words) must be read before all eight words can be assembled.

30 Database Storage. As illustrated by Fig. 10, there are three classes of scheduling, miscellaneous and system information received by the CPU 36, namely User Information 150, Command Information 152 and System Information 154. As illustrated by Fig. 11, the scheduling, miscellaneous and system information received by the set-top box 30 comprises a series of individual segments, with the each segment being associated with classification bits 174 which identify the segment's class.

35 "User information" includes scheduling and miscellaneous information, including program title information, program schedule information, and episode description information, as well as textual information such as news, weather, sports and information related to other subjects, each of which is associated with one of a plurality of sub-classes. Upon recognition by the CPU

1 36, User information is sent by the CPU 36 to one of a plurality of database writers 162 which corresponds to the sub-class. The database writer 162 then writes the scheduling and system information to memory 38 in an appropriate database 164, from which it may be recalled and displayed at a later time.

5 "Command Information" includes information which causes the IR output 60 to issue specific commands to external devices, such as the television receiver 32 or a VCR, such as commands to avoid real-time commercial broadcasts as discussed below. The CPU 36 receives Control Commands in a genetic format, and then retrieves corresponding IR control codes and sequences corresponding to the user's external device from an IR Library 166, which holds the
10 specifications for the user's particular device configuration. Control Commands may originate either from the user control device 50 or from broadcasts received by the RF receiver 34.

"System Information" includes command information which automatically alters the CPU's programming to initiate software bug fixes and add new services or databases without the interaction of the user. System Information will typically originate at the information
15 transmission subsystem 6.

Database Output. The arrangement by which the set-top box 30 retrieves information from the databases will be illustrated by the example of Fig. 12, in which a user, through the user control device 50, has elected to view news information. When a user chooses "news" from a screen display on which news is an option, a program called the news display application 182
20 is called by the operating kernel 180. The news display application 182 downloads data from the news database 184 and, based on the user's commands, downloads this data to a memory display list 186. The memory display list 186 sends the data to video hardware 188, which generates an RF output to transmit the data in video form through RF switch 58 for display on the television 32.

25 Automatic Display ordering. The set-top box 30 can enable the program schedule information to be displayed by the television receiver 32 with an alphanumeric ordering that is based on channel number or name, or with an based on the user's viewing habits. With reference to FIG. 13, to allow the channel ordering to be based on the user's viewing habits, the set-top box 30 maintains a running record of the amount of free the user views the various channels over a
30 selected period of time, and orders the channels based on a viewing time rating that is a function of actual viewing time over a current viewing period, for example, the previous day or week, and further based a decaying function of viewing time for viewing periods before the current viewing period. The set-top box 30 also can enable the ordering of other types of information, such as news information, that it enables the television receiver 32 displays based on the user's viewing
35 habits. In that operation, each item of news information is mated with one of a number of categories, and the set-top box 30 keeps track of the classes of news information viewed by the user. In addition, the set-top box 30 will order the items of news information based on the ages of the items and a priority value that is assigned by system 5.

1 Automatic Memory Recovery. Because the information in the set-top box's databases
is continuously updated, the set-top box 30 includes an arrangement for deleting old items and
otherwise recovering database storage space. Any of a number of conventional memory recovery
methodologies may be used to select existing memory space to be over-written by new data. As
5 illustrated by the flow chart of Fig. 14, when an application or database management tool
requires memory to store scheduling and system information, the kernel initiates a "memory
request" in step 192. If sufficient free memory is not available, each application is then called
with an "automatic memory recovery" request to execute "clear routine" thereby freeing low
priority memory items. In one particular embodiment, memory recovery is accomplished in three
10 ways:

(1) Certain database items are tagged with a specific "data type identifier," (or "slot
identifier") which allows future items having the same data type identifier to simply replace
them, recovering the memory occupied. by the original. This may be used, for example, to allow
a particular news story to be updated with new information by replacing the outdated
15 information.

(2) Most database items include aging information, such as information as to when
they were added to the database, so that they may be deleted a certain period of time after they
have been added to the database. For example, portions of memory in which miscellaneous
information, such as news, weather, and sports information, is stored may be used for new
20 information after a selected period of time, and portions in which television program schedule
information is stored may be used for new information after the program transmission time has
passed.

(3) Portions of memory in which database items which have low ratings under the
display ordering system may be used for new information a short time after they were loaded into
25 memory. A user rarely or never accesses certain types of miscellaneous information, portions
of memory in which those types of information are stored may be re-used before it has aged
greatly. If a user rarely or never watches a particular channel, or if the user seldom watches
television during a particular time period (such as early morning, midday, etc.) the schedule
application may delete the "scheduling information" relevant to that channel or time period when
30 additional memory is needed. In an alternative embodiment, an item's display ordering rating is
considered in combination with its age to determine whether the portions of memory in which
that item is stored should be re-used.

F. User Interface.

I. IR Remote.

35 Operation. According to commands issued by the CPU 36, the IR decoder will interpret
infrared control signals supplied by the user control device 50 in one of two modes: "raw" or
"demodulated." The "raw" mode is used during the system set-up as described above. In
"demodulated" mode, the IR decoder will generate a continuous digital "1" output to the CPU

1 when certain infrared control signals are detected and will otherwise generate a digital "0" output. Demodulated mode is used to enable the user to select a highlighted tile from various display screens using the user control device 50 and to provide the set-top box 30 with other commands.

5 In "raw" mode, the IR detector generates a time stamp for each infrared input it receives, and records data such as the IR carrier frequency, duty cycle and encoding method of such input.

In one embodiment, the user control device 50 a carrier frequency of approximately 80 Khz, which will insulate the IR detector from stray signals generated by other consumer electronic devices, most of which transmit at carrier frequencies in the 40-50 KHz range, and will also ensure that the user control device 50 will not interfere with the operation of other consumer devices having infrared inputs, particularly the television and external devices which may be part of the video system.

Layout. As shown in Fig. 15, the IR remote of the preferred embodiment contains 8 keys designated as follows:

15 GUIDE key 250
TV key 251
UP key 252
DOWN key 253 ("Directional Pad" buttons)
20 LEFT key 254
RIGHT key 255
LEFT SOFTKEY 256
RIGHT SOFTKEY 257

25 Universal Remote Usage. When the system is in TV mode, the Directional Pad buttons and the softkeys function to control the television and external devices. In that mode, the up and down keys 252 and 253 are used to increment and decrement the channels, respectively, the right and left keys 255 and 254 are used to increase and decrease volume, the left softkey 256 is used to turn power on and off, and the right softkey 257 is used to control device muting.

30 II. Screen Displays.

1. Basic Screen Display Features. The set-top box can present a variety of screen displays on the television. As described above, the screen displays are provided by the set-top box 30 by means of an RF signal coupled through the RF switch 58, and when the set-top box provides such a screen display, it enables the television receiver 32 to switch to the selected channel (such as channel 3 or 4) for screen display by providing an appropriate infrared signal to the television receiver's infrared remote control input. As illustrated in Fig. 16, every screen display has a common Banner Area 240 which describes the functions of the softkeys for that screen and lists the title of the screen display. Most screen displays also include a number of

1 boxes enclosing text, each of which is referred to as a "tile" 244, and which collectively form a "grid" 242.

When the user has selected a tile, or moved the cursor onto a tile using the directional keys of the IR remote, the color of the tile will change, and it is said to be "highlighted." In screen displays that include program titles, different types of programming can be represented by tiles of differing colors.

If the highlighted tile is near an edge of the screen display, the screen display will automatically "scroll" to bring the highlighted tile near the center of the screen display. Certain screen displays do not allow the highlighted tile to be at the edge of the display screen unless no information is contained off-screen beyond the edge of the display screen.

All screen displays also have an information area 246 which displays further information about the selected tile, such as episode information about a selected program or additional information about a news headline.

Navigation in Screen Displays. The buttons of the user control device 50 enable the user to access all screen displays and features of the system that may be controlled by users. Pressing the directional buttons 252-255 of the IR remote 50 moves the cursor and highlighted tile up, down, left and right on the grid. Pressing the GUIDE key 250 will select a highlighted tile and switch the system to the next display screen (bringing up the Navigation Screen if the user is currently watching television programming). Pressing the TV key 250' will return to television programming from the screen displays, either tuning to a new station if the Program Grid screen display was active immediately prior to pressing TV and the program highlighted on the Program Grid is available, or tuning back to the original station being watched if not. In screen displays that display a grid of television program scheduling information (i.e. Program Grid, Programs by Title, TV Movies and Sports Ticker), LEFT SOFTKEY 256 will cause the highlighted program to be recorded. A summary of the functions available in each display screen is illustrated in Table I below:

Current Display	GUIDE key fn	TV Key function	LEFT key function	RIGHT key fn	Up/Down key fn	Left/Right Key Fn
Television viewing	Brings up Navigation Screen	Brings up Previous Screen	MUTE television	TV Power On/Off	Channel Up/Down	Volume Up-down
Navigation Screen	Bring up Selected Screen	Return to TV Viewing	various	various	select screen option	choose screen tile

1
5
10
15

Program Grid	Bring up TV Movie Screen	Tune to selected program	Record selected program	Advance display one day	grid select up-down	grid select left/right
TV Movie Screen	Bring Up Sports Screen	Tune to selected program	RECORD selected program	unused	grid select up/down	grid select left/right (choose day)
Sports Screen	Bring up News Screen	Return to TV Viewing	[record selected game]	unused	grid select up/down	grid select left/right
News Screen	Return to TV Viewing	Return to TV Viewing	[previous page of text]	[next page of text]	grid select up/down (Headline)	Text Page Select Fore/Back

Navigation Screen. Referring to Fig. 17, the Navigation Screen 258 is the first screen displayed after the user presses the GUIDE button 250 of the user control device 50. The Navigation Screen lists the major screens that are available in one embodiment, namely, TV program Listings, TV Movies, Sports and News. In addition, certain non-screen features of the system have tiles on the Navigation Screen, including the commercial avoidance feature, as will be described below. The Navigation Screen may also include other information, such as personal messages, reminders or paid advertising.

Program Grid. In the Program Grid 260, shown in Fig. 18, tiles contain television program titles 262, arranged vertically by broadcaster, such as the station or network, and horizontally by time. The information area 263 displays further episode information about the highlighted tile. The RIGHT SOFTKEY 257 advances the screen display one day in time.

Sports Ticker. As shown in FIG. 19, the Sports Ticker display shows information relating to different sporting events and their ongoing scores. When the highlighted tile represents a specific sports event, further information relevant to that event is shown in the Information Area. If events are televised, an icon, which in one embodiment is a small representation of a television receiver, is displayed in the tile. For these televised events, a user can cause the set-top box 30 to enable the television receiver 32 to switch to that program by highlighting and selecting the tile associated with the event in the same manner that he or she can enable the set-top box 30 to select programming through the Program by Title screen.

News. As shown in Fig. 20 the News display uses a scrolling list of tiles to show brief headlines of news stories. The user may use the user control device 50 to select a tile, and the Information Area shows the full text of the news story associated with the selected tile.

1 Other Screens. Other embodiments of the invention may include screen displays with features such as horoscopes, crossword puzzles.

I. Other Features

1. Recording Programs.

5 Selection of Programs for Recording. In the display screens including program titles, the user may select a program for recording by highlighting that program's tile and pressing the LEFT SOFTKEY 256. When a program is scheduled to be recorded, the background color of its tile is changed to a selected alternate color, which in one embodiment is red. Programs can be scheduled to be recorded at selected intervals, including "once" or "always." When a program
10 is scheduled to be recorded once, the CPU will cause the VCR to record the program at the date and time selected. The user may select recording once by pressing the LEFT SOFTKEY 256 once on a tile. When a program is scheduled to be recorded regularly, the CPU will cause the VCR to record the program each time it occurs in the time slot originally selected by the user. The user may select recording regularly by pressing the LEFT SOFTKEY 256 twice when a tile
15 is highlighted.

As shown in the flow chart of Fig. 21, the automatic recording process varies depending on the particular system configuration. In step 270, the recording process is initiated by pressing the LEFT SOFTKEY 270, and if it is determined in step 271 that the system does not include a cable decoder, as indicated during the set-up procedure described above, at the time of broadcast
20 of a program scheduled to be recorded, the set-top box's IR output 60 will send a channel change in step 272 and a "Record" command to the VCR in step 273, and at the end of the scheduled program, a "Stop" command will be sent to the VCR. If a cable decoder is used in the system, a channel change command will be sent to the cable decoder a selected amount of time in advance of the scheduled recording time in step 274 and a "Record" command will be sent to the
25 VCR by the IR Output 60 in step 273 at the time of scheduled broadcast; a "Stop" command will be sent to the VCR at the scheduled end of the broadcast.

2. Commercial Avoidance.

In one embodiment, the set-top box 30 can enables users in certain areas of the United States to avoid broadcast advertising during the viewing or recording of television programs on
30 certain channels. This feature is selected by the user through a tile on the Navigation Screen. While this tile is seized, moving the directional control up or down chooses between the following options: "Off", "While Viewing", "While Recording", and "While Viewing and Recording". The implementation of each of these options will now be discussed.

"While Recording": Referring to Fig. 22, if a program is being recorded when a commercial break occurs as described below, the IR output 60 will send a "pause enable" signal
35 to the video recorder in step 304 and will not send a "pause disable" signal to the video recorder in step 308 until the end of the commercial break is detected in step 306. As a result, the video recorder will not record commercials. This feature saves videotape during the unattended taping

1 of programming.

"While Viewing": Referring to FIG. 23, If a user, who has selected this option in step 320, is viewing a channel ("Channel A") when a commercial break occurs as detected in step 322, the IR output 60 of the set-top box 10 will issue a "mute enable" command to television 32 in step 324. The television then substantially diminishes the volume of the television for the duration of the commercial break in step 326, and will not issue a "mute disable" command to the television 32 in step 330, to restore the volume in step 332, until the commercial break is over in step 328. If the system detects in step 334 that the user has changed the channel' (to "Channel B") using the user control device 50 after the "mute enable" command is issued, the IR output 60 will automatically issue a "mute disable" command in step 336, restoring sound for viewing of Channel B in step 338. In addition, when the end of the commercial break on Channel A is detected in step 340, the IR output 60 will automatically issue a command in step 342 to the television or cable decoder to tune back to Channel A in step 344. Then, in step 346, Channel B will be stored in a memory means as an "alternate channel" to be switched to during commercial breaks on Channel A. Upon the occurrence of the next commercial break on Channel A, the system will automatically tune the television to Channel B for the duration of the commercial break. Channel B may also be a display screen (such as Sports Ticker or News).

The system 5 accomplishes "commercial avoidance" as follows. As shown in FIG. 24, in one embodiment which may be used in areas in which television programming is transmitted to local television affiliates and rebroadcast without delay (typically the Eastern and Pacific U.S. time zones), commercial monitoring centers 380 monitor television programming on those channels and determine when a commercial break begins and ends. At the beginning and end of each commercial break, the commercial monitoring center 380 transmits to the central broadcasting computer 10 a message indicating the channel on which a commercial break has begun. The central broadcasting computer 10 then transmits, as system information, Control Information over the WAN 16 for transmission by RF transmitters 386 (corresponding to paging terminals 18 in FIG. 1) in those areas in which the commercial break has occurred. The Control Information will be received by individual set-top boxes 30 and decoded and interpreted by their CPUs to be commercial avoidance information.

As shown in Fig. 25, in one embodiment the commercial monitoring center 380 includes at least one human observer monitoring a television 386 tuned to the channel being monitored. At the beginning and end of a commercial break on the channel being monitored by observer 384, observer 384 will depress a button 387 indicating to a computer 388 the beginning and end of the commercial break on such channel. The computer 388 will then transmit a message to the central broadcasting computer 10, as described above. In an alternate embodiment shown in Fig. 26, individual observer error is minimized by causing multiple observers to view each channel and depress individual buttons at the beginning and end of a commercial break. Logic module 390 of the computer 388 then logically combines the signals generated by the buttons of the

1 observers watching the same channels and sends a commercial break indication to the central
broadcast computer when it receives indications from more than a predetermined number of
observers (e.g. three) identifying the beginning and end of a commercial break on the channel.

5 The commercial avoidance feature can also be provided in areas in which the
transmission of programming is delayed from an original transmission, without requiring
providing observers for those areas as described above. In that operation, the commercial
monitoring center 380 not only enables transmission of Command Information identifying the
beginning and end of a commercial break in original transmission areas, that is, in areas in which
10 program transmission is not delayed, it also enables transmission of Command Information in
delayed transmission areas which identifies the times at which commercial breaks begin and end,
which the set-top boxes 30 in those areas will store in their respective memories 38. If a user uses
his or her set-top box 30 to control display or recording of a program for which commercial
avoidance information has been provided, the set-top box 30 can use the commercial break begin
and end times in the memory to control volume in connection with display of a program by the
15 television receiver 32, as well as to control pause of a VCR in connection with recording of a
program by a VCR.

3. Remote Operation.

As illustrated by Fig. 27, the system includes a central office 430 having a plurality of
telephone connections 432, human operators 434 and terminals or stand-alone personal
20 computers 436 networked to the central information broadcasting computer 10. In the event that
a user 350 desires to issue commands to his set-top box while remote from the box, for example,
if he forgot to program his VCR to record a program, he may telephone the central office 430,
identify himself and provide a security code to the operator 434. If the operator verifies the user's
identity (in a preferred embodiment, using a commercially available database including user
25 name, security codes and set-top box serial numbers), the user may tell the operator what
command he would like to remotely issue to his set-top box 30. The operator will then access
the central information broadcasting computer 10 through his terminal or personal computer 436,
and instruct the central information broadcasting computer 10 to transmit an "individualized
command" through the WAN 16 to the RF transmitter 18 servicing the user's area. An
30 "individualized command" is a control command containing the serial number of the user's set-
top box 30, and which will be disregarded by all set-top boxes other than the set-top box 30
having that serial number. Upon receipt and recognition of the individualized command by the
user's set-top box 30, the user's set-top box 30 will execute the command.

35 The foregoing description has been limited to a specific embodiment of this invention.
It will be apparent, however, that various variations and modifications may be made to the
invention, with the attainment of some or all of the advantages of the invention. It is the object
of the appended claims to cover these and such other variations and modifications as come
within the true spirit and scope of the invention.

1 WHAT IS CLAIMED IS:

1. A system comprising:

A. A central facility for periodically broadcasting television program scheduling information, the television program scheduling information being broadcast
5 separate and apart from television programming;

B. a control unit for use in connection with a television receiver for receiving television programming on a plurality of channels, the television receiver having a wireless remote control input for receiving a wireless remote control signal for controlling the television receiver and a program input for receiving
10 program information, the control unit being further for use in connection with an auxiliary television program receiving device for receiving television programming on a plurality of channels, the television receiver having a wireless remote control input for receiving a wireless remote control signal for controlling the television receiver and a program input for receiving program
15 information, the control unit comprising:

- i. a program scheduling receiver for receiving and storing said television program scheduling information;
- ii. a switch for connection to said television receiver and responsive to operator input for selectively providing said stored television program scheduling information and program signals from a program source to said program input as said program information to be displayed by said
20 television receiver;
- iii. a program identifier for receiving operator input relative to said displayed television program scheduling information identifying a program, and
25
- iv. a television receiver control signal generator for generating a wireless remote control signal for transmission to the wireless remote control input to control the channel of said television receiver in response to the identified program as determined by said program identifier;

30 wherein the control unit receives programming signals from said auxiliary television program receiving device for provision as said program information to the program input of said television receiver, the television receiver control signal generator generating a wireless remote control signal for transmission to the wireless remote control input of said auxiliary television program
35 receiving device to control the channel of said auxiliary television program receiving device in response to the identified program as determined by said program identifier.

1 2. The system as defined in claim 1 wherein central facility includes a pager terminal for transmitting said television program scheduling information in the form of radio frequency signals, and said program scheduling receiver receives radio frequency signals.

5 3. The system as defined in claim 2 wherein said radio frequency signals have a frequency within a range reserved for nationwide pagers.

 4. The system as defined in claim 2 wherein said radio frequency signals have a frequency of approximately 931 MHz.

10

 5. The system as defined in claim 1 wherein said program scheduling receiver information receiving means comprises an RF receiver for receiving signals from said central facility.

15

 6. The system as defined in claim 1 wherein said central facility further broadcasts at least one additional type of information, the programming scheduling receiver further receiving and storing said additional type of information, said switch being further responsive to operator input for providing said stored additional type of information to be displayed by said television receiver.

20

 7. The system as defined in claim 1 wherein said system further includes a video cassette recorder, and said program identifier receives operator input relative to said displayed television program scheduling identifying a program to be recorded, the control unit further including a video cassette recorder control for controlling said video cassette recorder to record said identified program.

25

 8. The system as defined in claim 7 in which said video cassette recorder receives recording control information by an electromagnetic signaling link, the video cassette recorder control including a transmitter for transmitting electromagnetic signals for controlling said video cassette recorder to record said program identified to be recorded.

30

 9. The system as defined in claim 1 in which said television receiver receives channel control information by an electromagnetic signaling link, the television receiver control including a transmitter for transmitting electromagnetic signals for controlling said television receiver to display said identified program.

35

 10. A system as defined in claim 1 in which the auxiliary television program receiving device is a cable box.

1

11. A method for setting a channel selector of a television receiver to a desired channel by using a display monitor with a screen, the method comprising the steps of:
displaying on the screen a plurality of tiles;
5 displaying in the respective tiles ongoing scores of sporting events that are being telecast on different channels;
highlighting one of the tiles; and
setting the selector to receive the channel on which the sporting event displayed in the highlighted tile is telecast.

10

12. The method of claim 11, in which some of the ongoing scores displayed in the tiles are for sporting events not being telecast, the method additionally comprising the step of displaying an icon in each tile in which an ongoing score for a sporting event being telecast is displayed.

15

13. The method of claim 12, additionally comprising the steps of displaying on the screen an information area and displaying in the information area information relevant to the sporting event displayed in the highlighted tile.

20

14. The method of claim 13, additionally comprising the steps of changing the highlighted tile and changing the information displayed in the information area to correspond to the sporting event displayed in the changed highlighted tile.

25

15. The method of claim 11, additionally comprising the steps of displaying on the screen an information area and displaying in the information area information relevant to the sporting event displayed in the highlighted tile.

30

16. The method of claim 15, additionally comprising the steps of changing the highlighted tile and changing the information displayed in the information area to correspond to the sporting event displayed in the changed highlighted tile.

35

17. The method of claim 11, additionally comprising the steps of generating a television mode switching command to which the setting step responds and displaying the television program telecast on the received channel on the screen instead of the tiles.

18. The method of claim 11, additionally comprising the steps of generating a recording command to which the setting step responds and recording the television program telecast on the received channel on a VCR responsive to the recording command.

1 19. A method for presenting television program listings to television viewers comprising the steps of:

 broadcasting television program listing data from a plurality of pager terminals that cover a specific geographic region;

5 receiving the data in the vicinity of each of a plurality of television receivers that have a display screen;

 storing the received data in a memory associated with each television receiver; and
 processing the data to display television program listings on the screen.

10 20. The method of claim 19, in which the broadcasting step broadcasts the television program listings during the night.

 21. The method of claim 19, in which the broadcasting step broadcasts the television program listings when there is low usage of the pager terminals.

15 22. The method of claim 19, in which the data is broadcast in the 931 MHz frequency band.

 23. The method of claim 19, in which the data is broadcast in analog form.

20 24. The method of claim 23, in which the data is converted to digital form before the storing step.

 25. The method of claim 19, additionally comprising the steps of :
25 transmitting information including program schedule listings from a variety of sources to a central computer that stores the transmitted information in its own databases;
 transmitting the stored information over a wide area network to the pager terminals in TCP/IP communications format; and
 converting the information at the pager terminal into the program schedule data
30 suitable for broadcasting from the pager terminals.

35

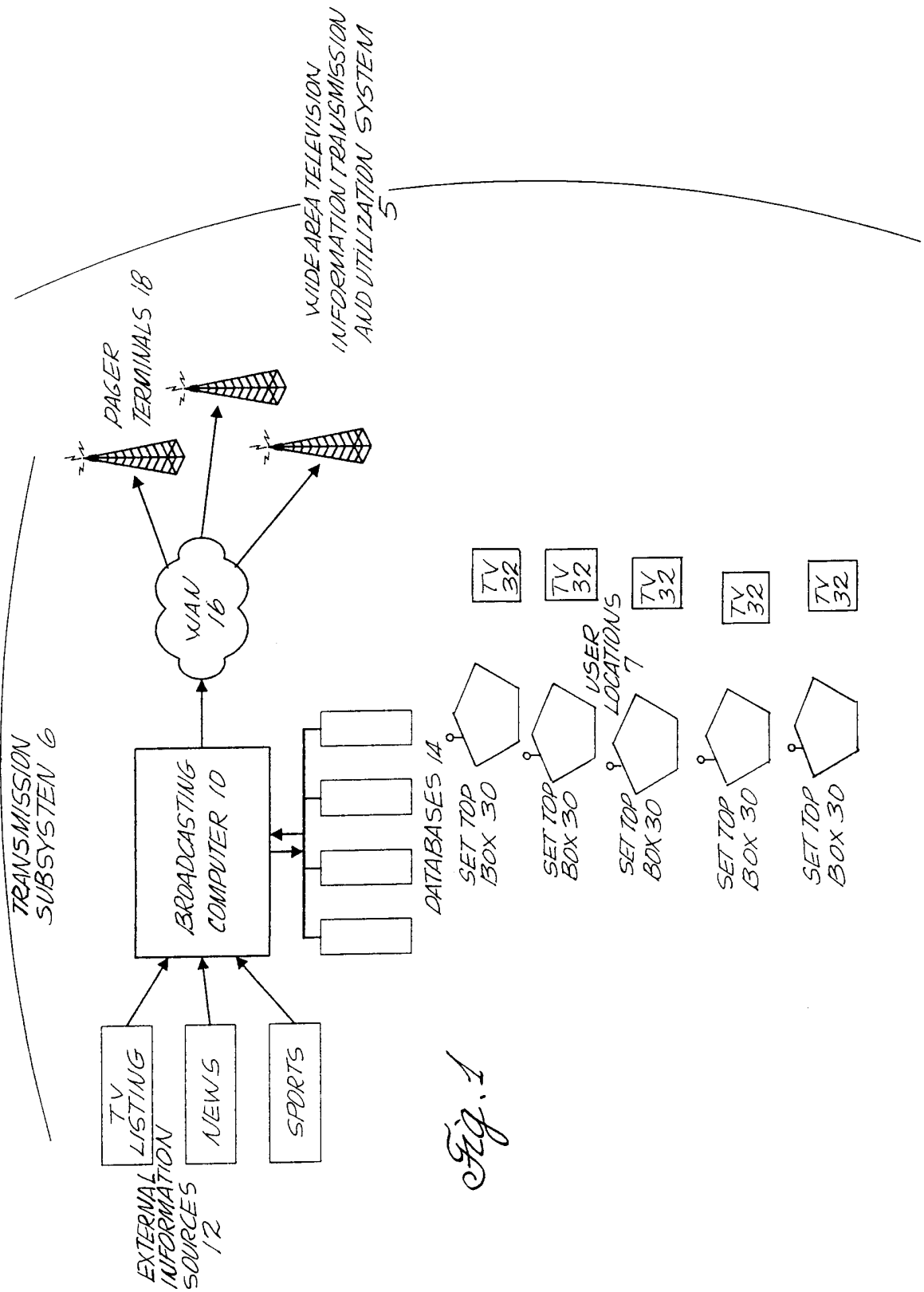

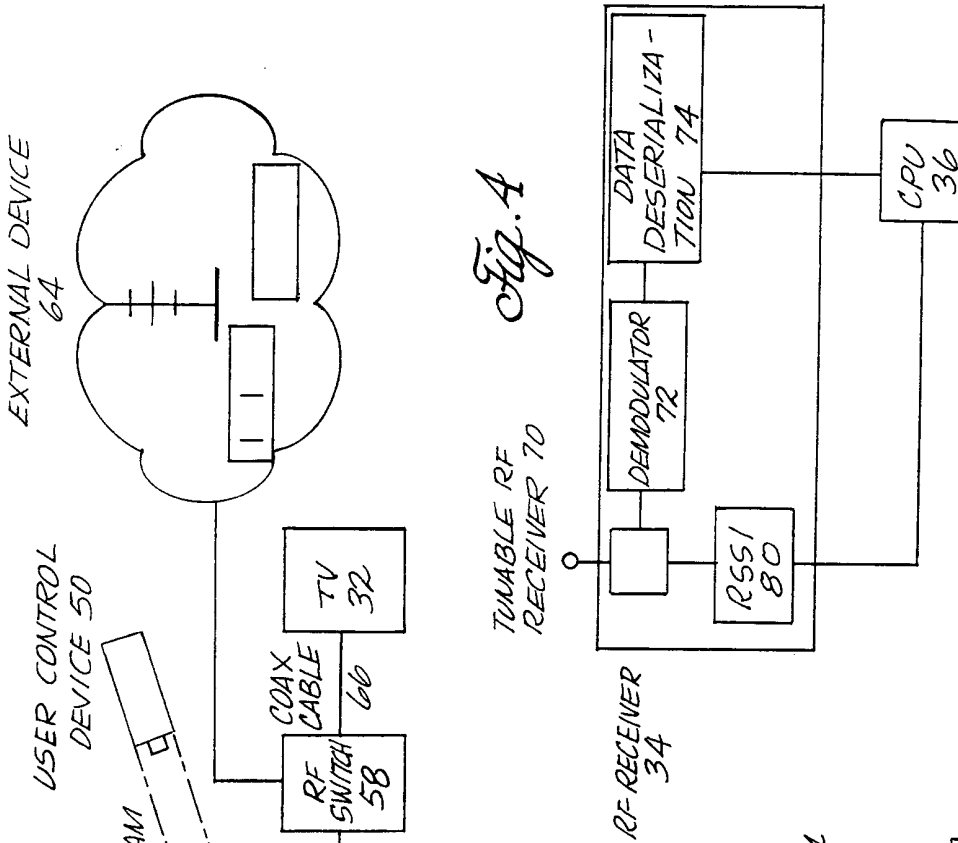

Fig. 4

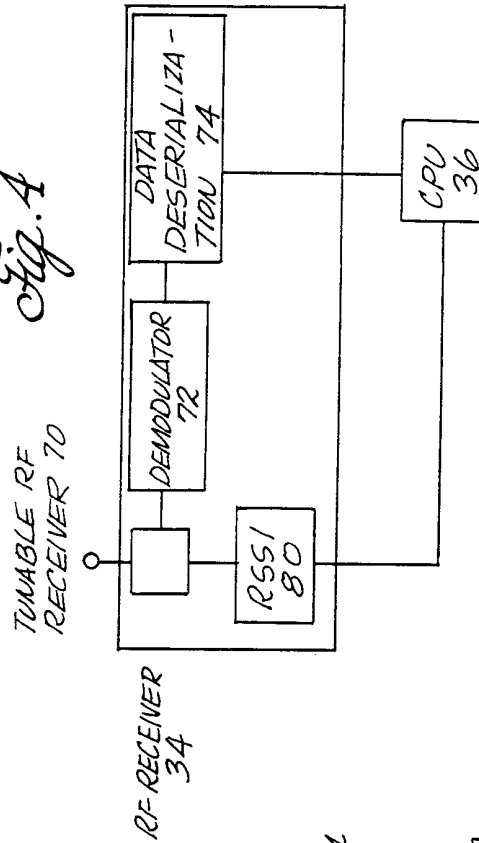
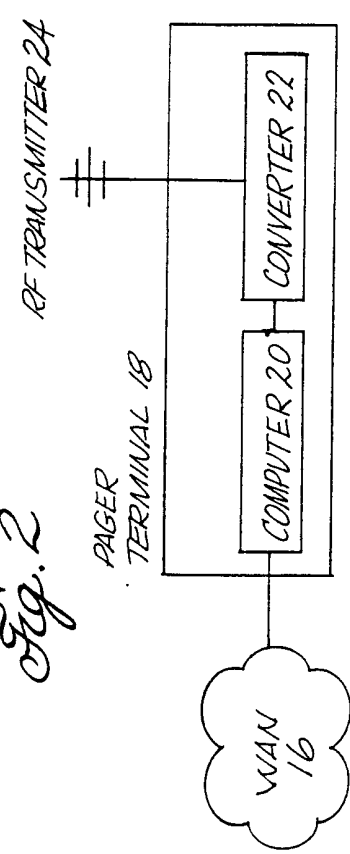

Fig. 2



DATA DESERIALIZATION 7A

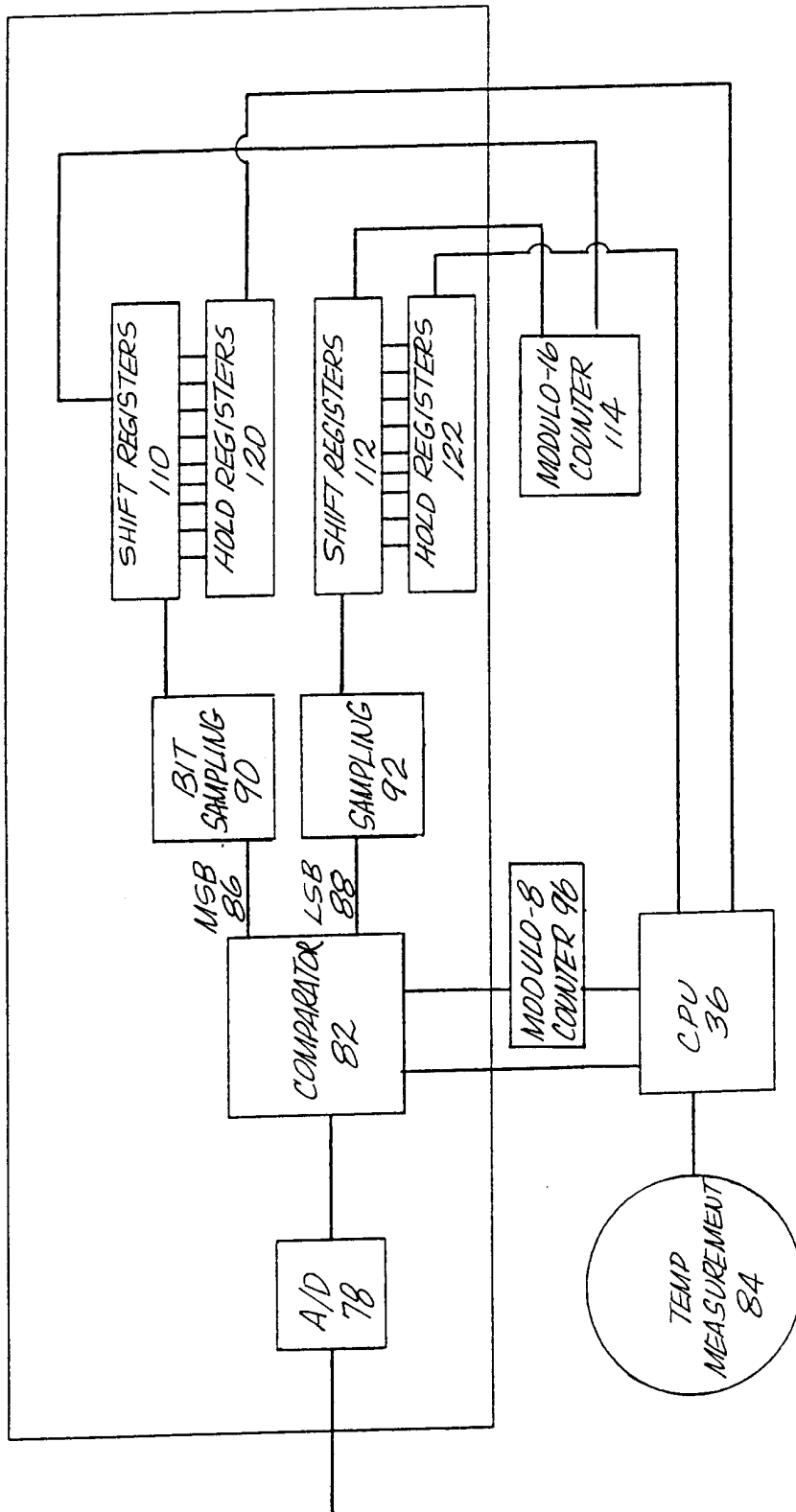

Fig. 5a

Fig. 56

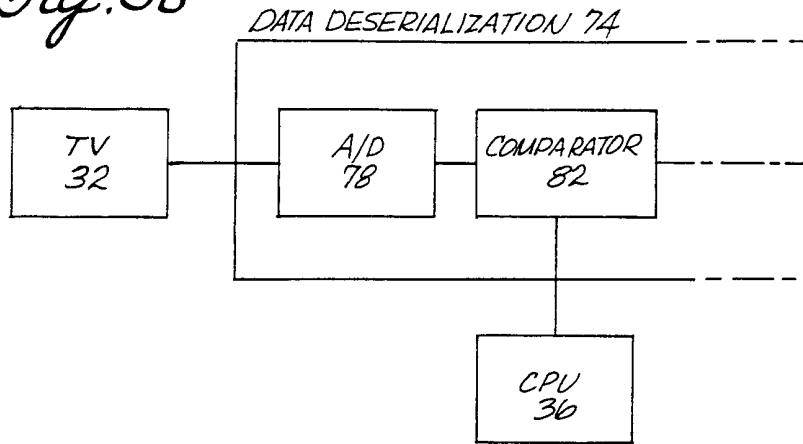

Fig. 6

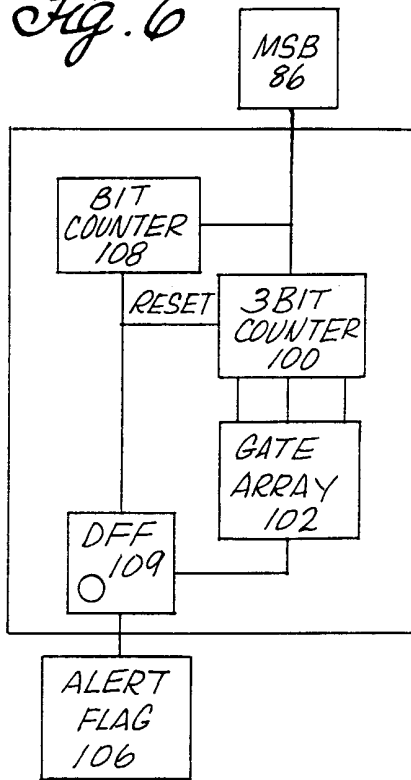

Fig. 7a

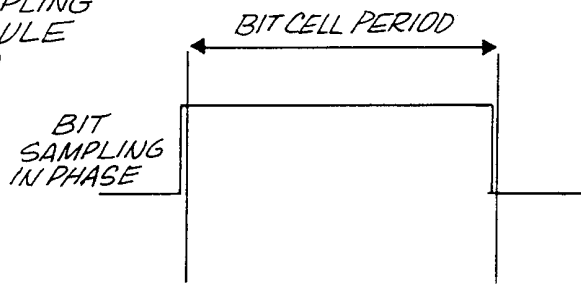

Fig. 7b

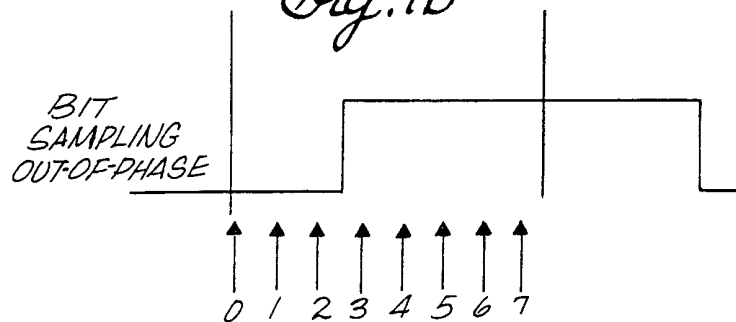

Fig. 8

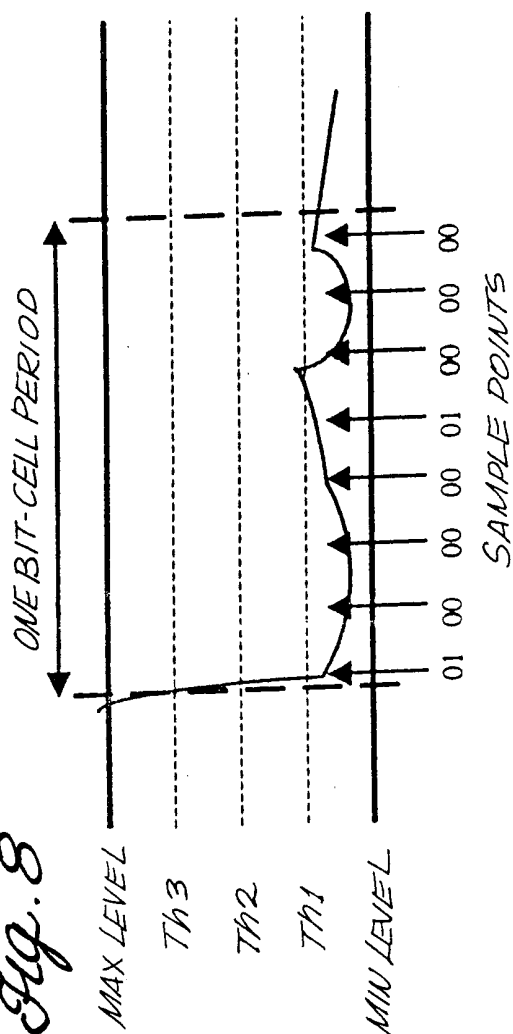
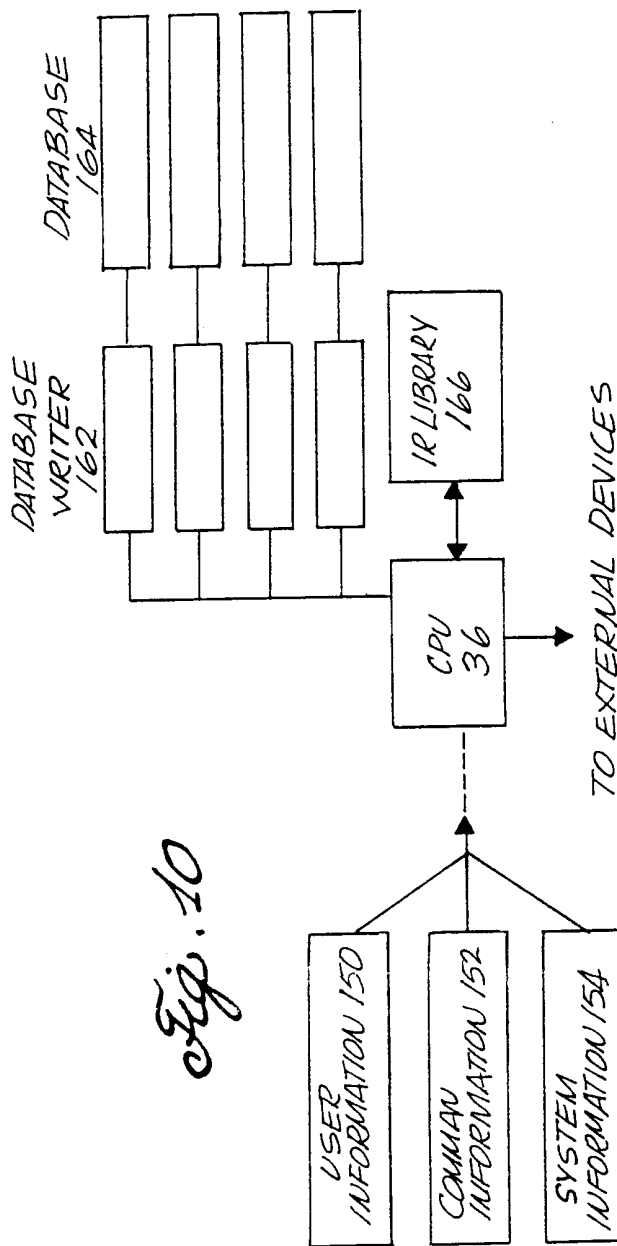

Fig. 10



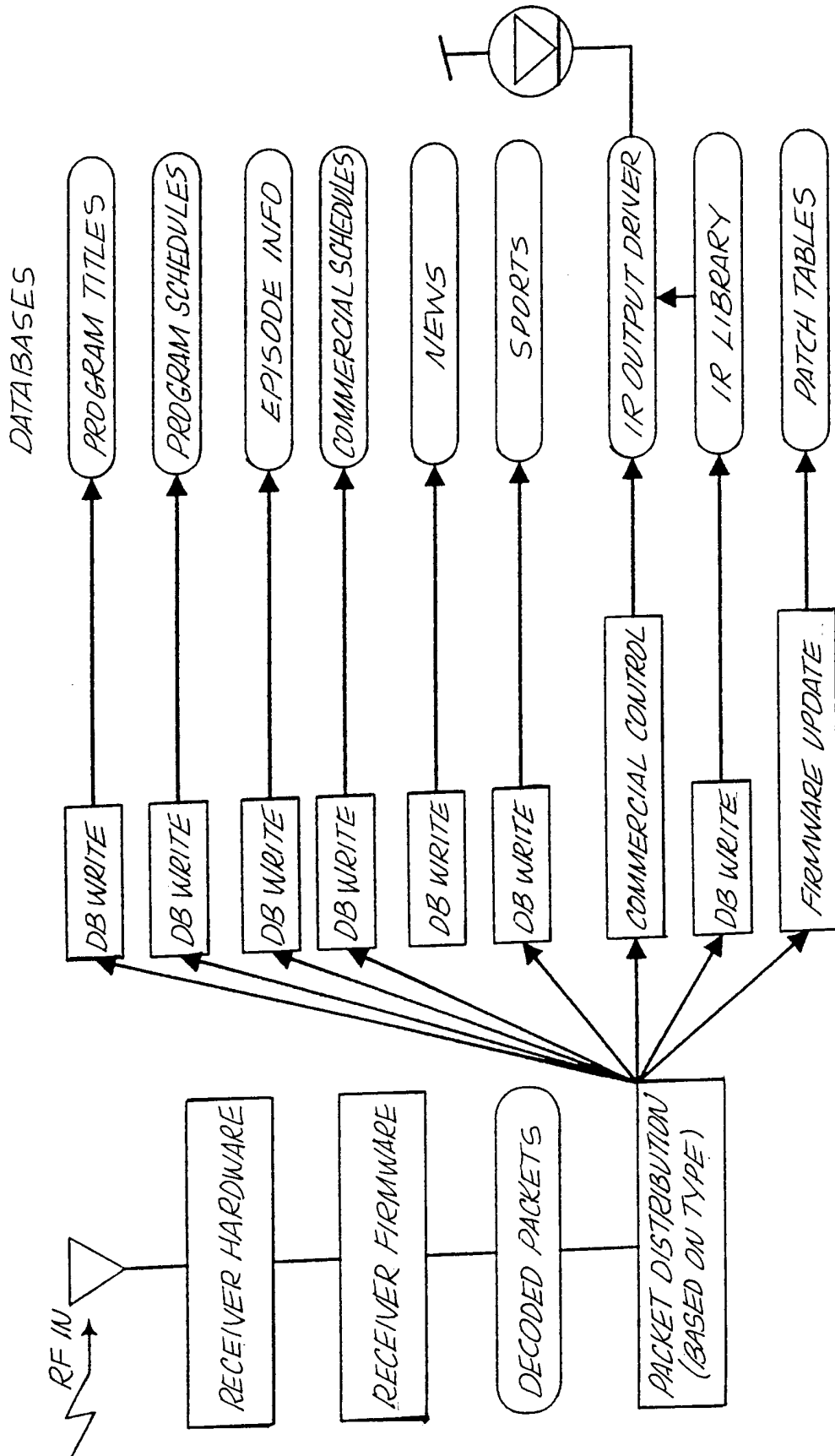

Fig. 9

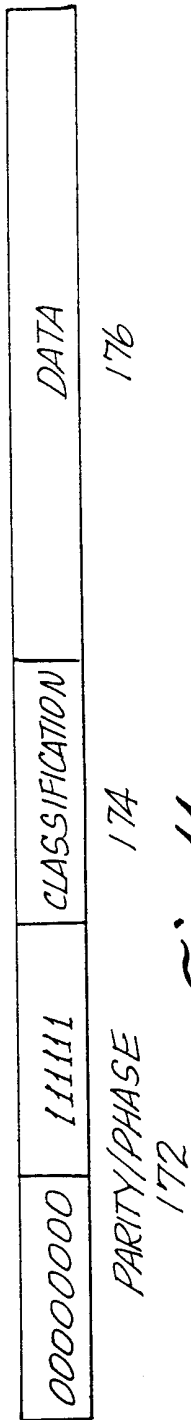

Fig. 11

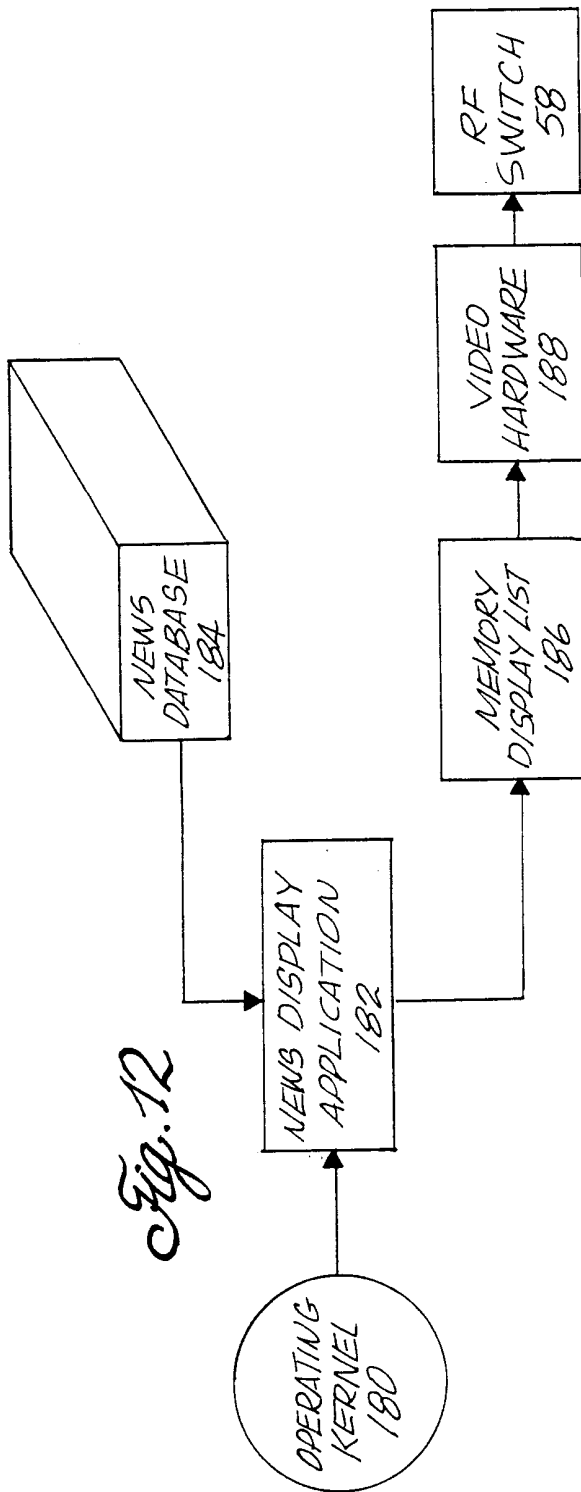

Fig. 12

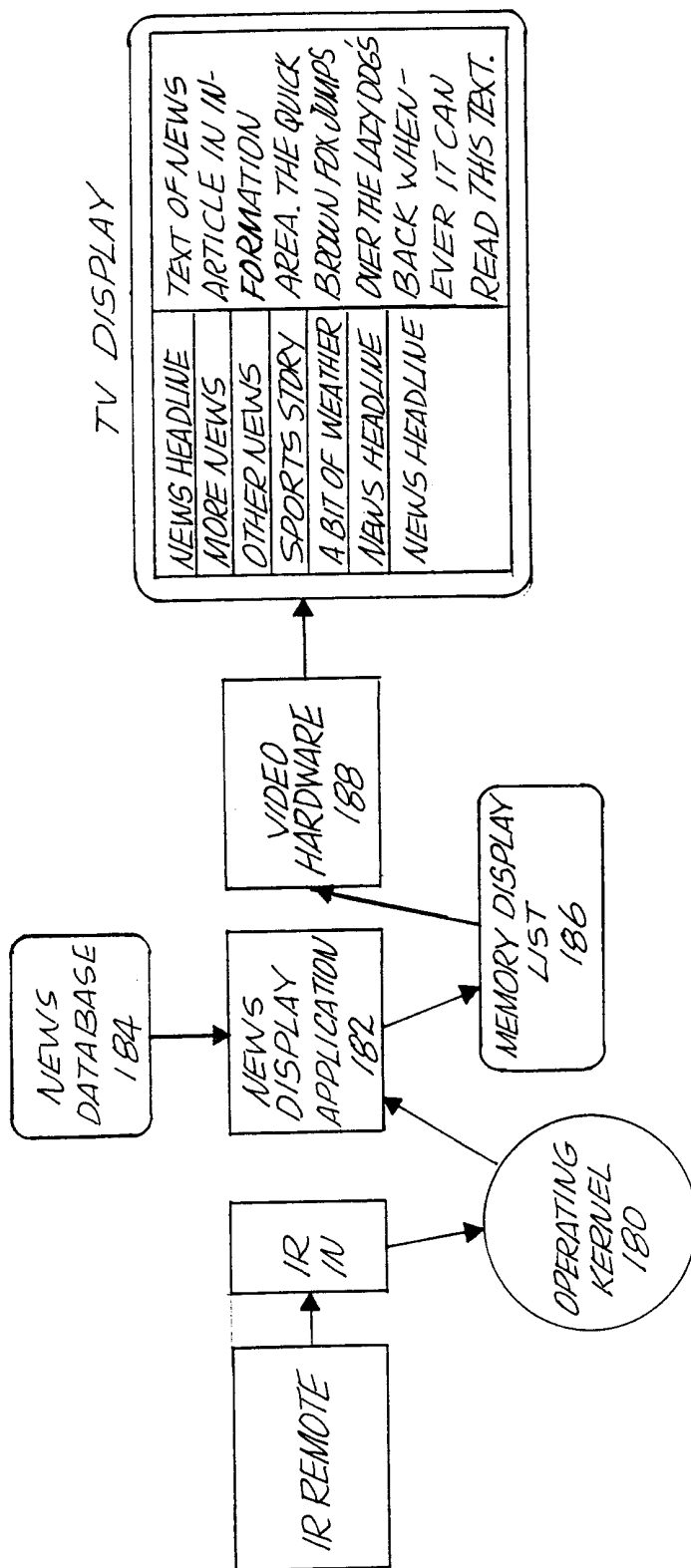

Fig. 13

Fig. 14

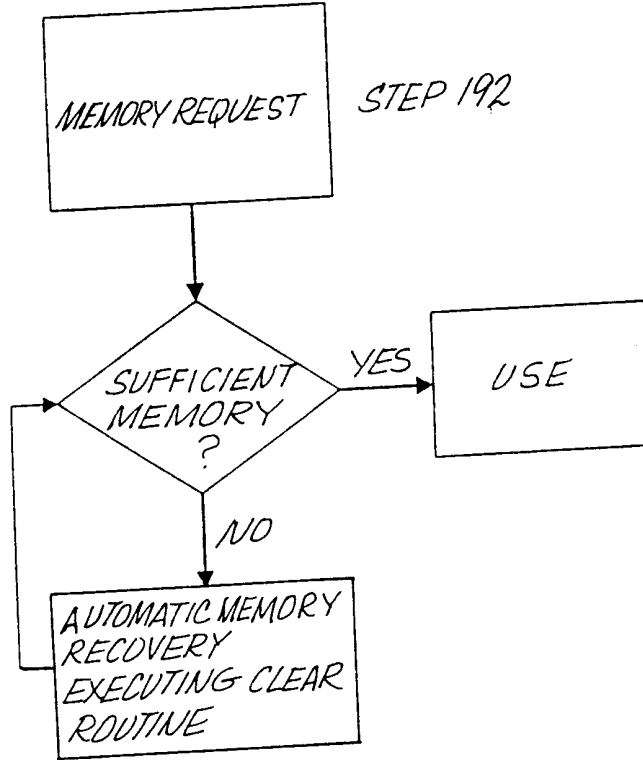

Fig. 15

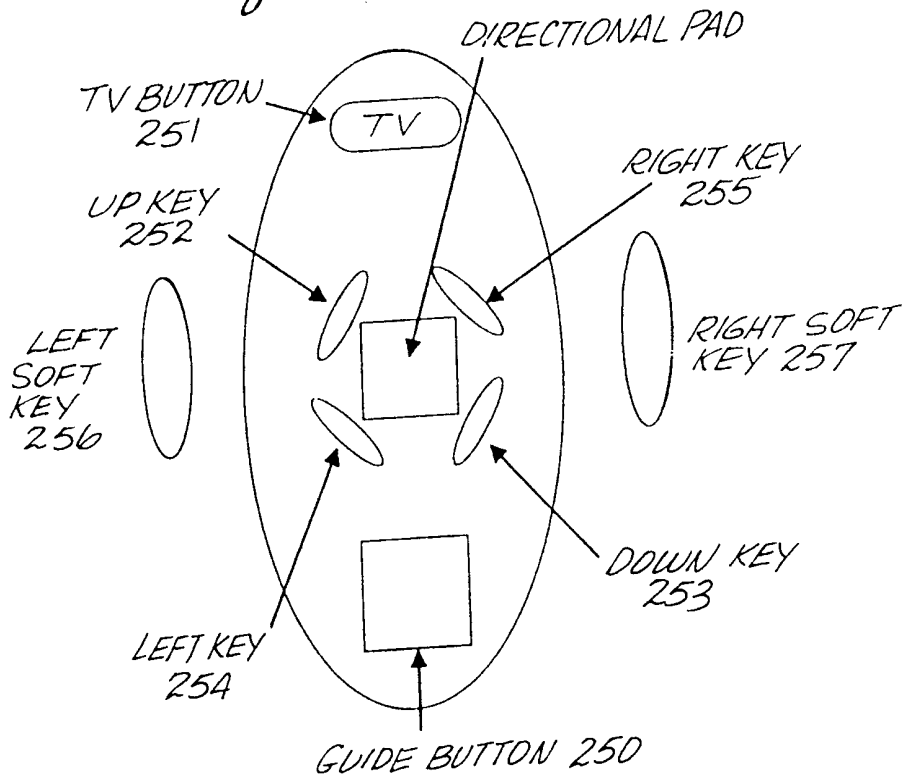
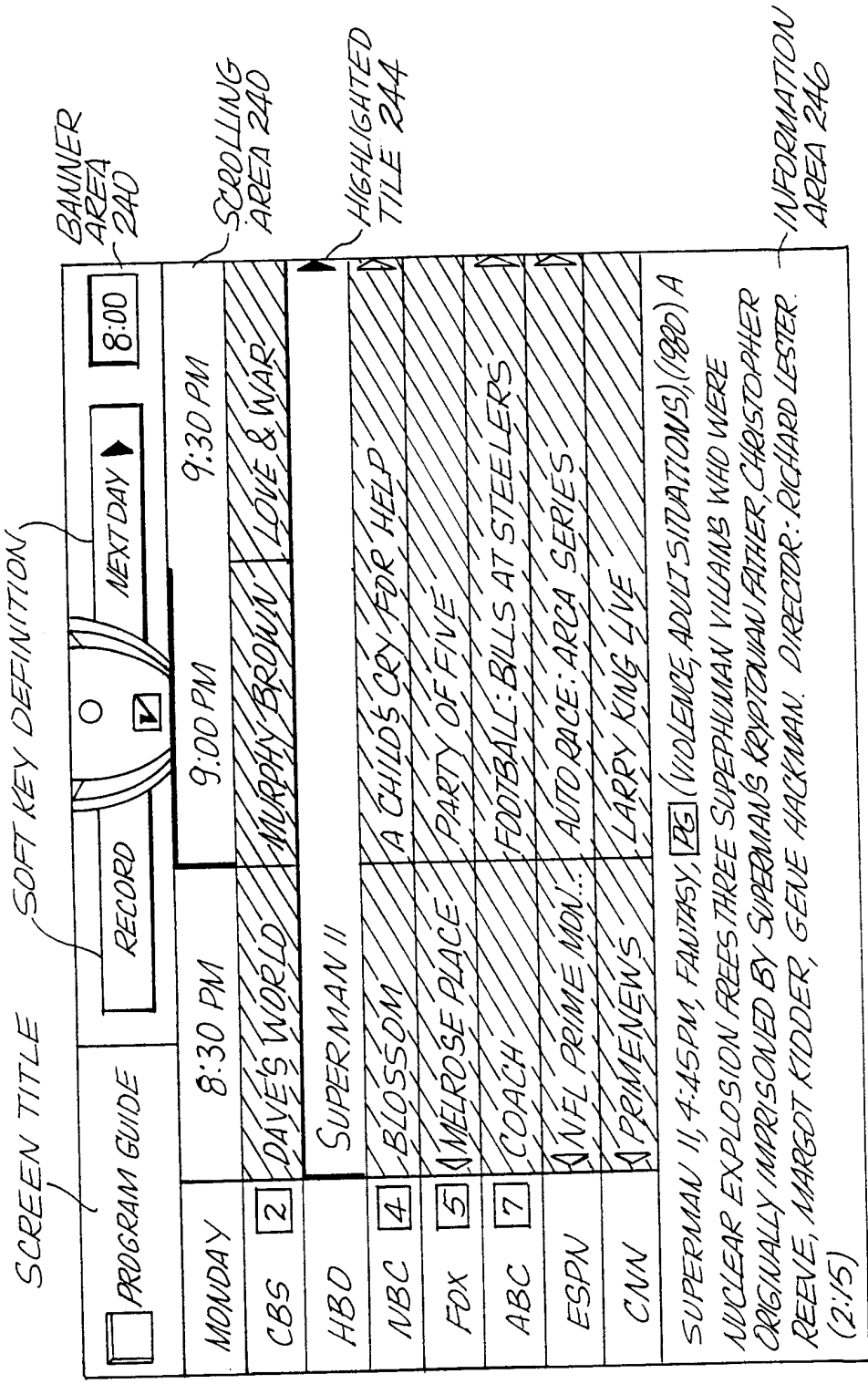

Fig. 16



11/19

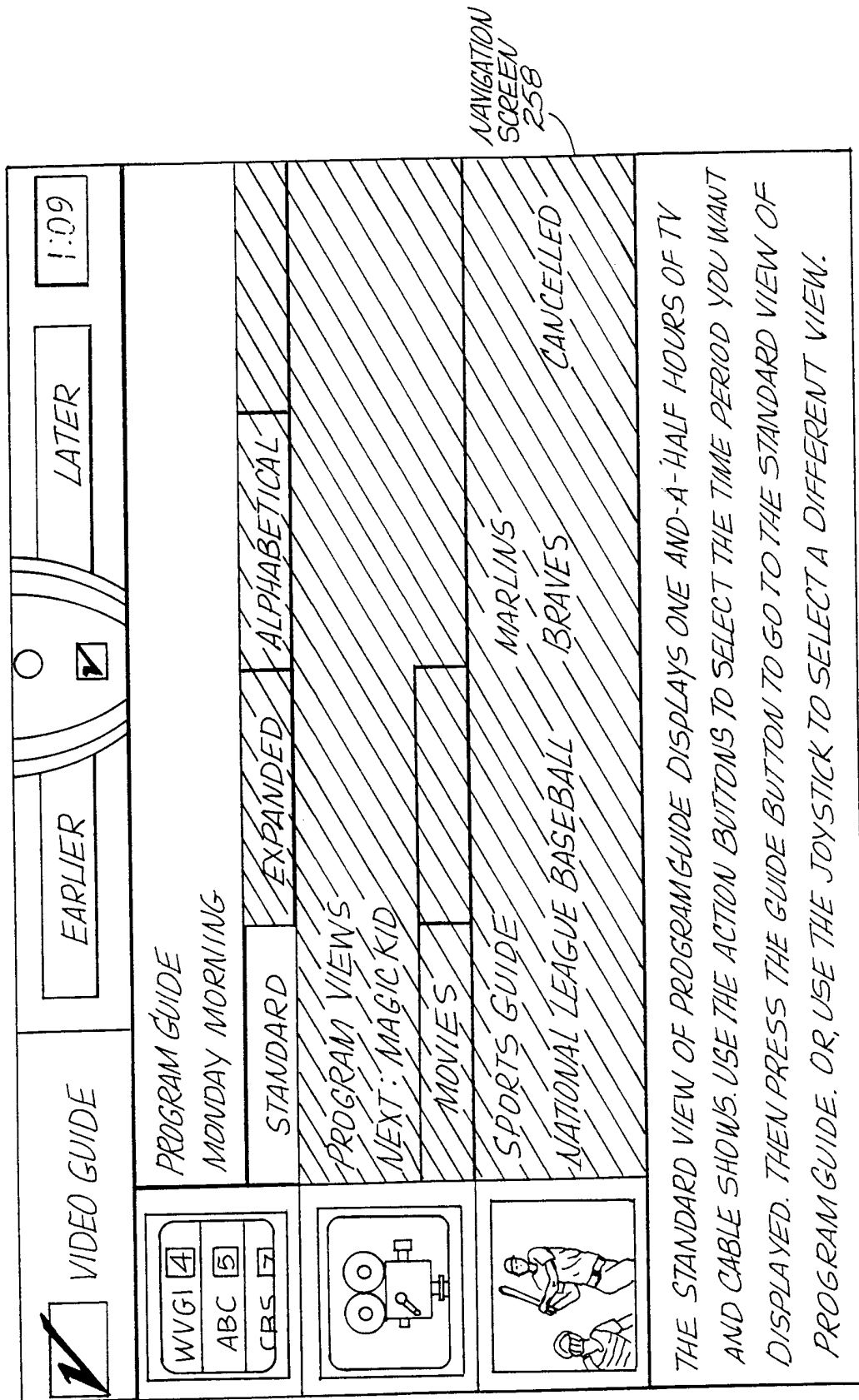

Fig. 17

Fig. 18

PROGRAM GUIDE		RECORD	NEXT DAY	8:00
MONDAY	8:30 PM	9:00 PM	9:30 PM	
CBS [2]	DAVE'S WORLD	MURPHY BROWN	LOVE & WAR	
HBO	SUPERMAN II			
NBC [4]	BLOSSOM	A CHILD'S CRY FOR HELP		
FOX [5]	MELROSE PLACE	PARTY OF FIVE		
ABC [7]	COACH	FOOTBALL: BILLS AT STEELERS		
ESPN	NFL PRIME MON...	AUTO RACE: ARCA SERIES		
CNN	PRIME NEWS	LARRY KING LIVE		
SUPERMAN II: 4:45, FANTASY [DE] (VIOLENCE, ADULT SITUATIONS), (1980) A NUCLEAR EXPLOSION FREES THREE SUPERHUMAN VILLAINS WHO WERE ORIGINALLY IMPRISONED BY SUPERMAN'S KRYPTONIAN FATHER. CHRISTOPHER REEVE, MARGOT KIDDER, GENE HACKMAN. DIRECTOR: RICHARD LESTER. (2:15)				

PROGRAM GRID 260

TITLE 262

INFORMATION AREA 263

Fig. 19















SPORTS GUIDE		RECORD	○	☑	NEXT	5:13
	PISTONS ... 25-32-27	110	F	SUNS	25-25-32-35	117
	SUPERSONICS ... 30-32-35	133		HAWKS	29-23-36-34	122
	NETS ... 25-18-23	8	F/OT	MAVERICKS	30-30-24-22	106
	KNICKS ... 20-20-16	9	92	SPURS	33-27-28-28	116
	TRAILBLAZERS ... 24-15-30	90	F	JAZZ	(202)	12:00 PM
	NUGGETS ... 30-24-30	110		HORNETS	1	
	BULLS (198)	12:00 PM		CAVALIERS	3 1/2	1:00 PM
	PACERS 3			BULLETS	(181)	
	CELTICS (207)	2:30 PM		76ERS	(212)	3:30 PM
	BUCKS 3			ROCKETS	14	
GAME TIME: 12:00 PM (WHDH 7 12:00 PM)						

Fig. 20

 NEWS GUIDE	 NEXT	5:17
DDW ↑ 4.50 AD73.35	THE VIDEO GUIDE NEWS  50° 35°	
SHUTTLE'S RETURN DELAYED	STORMS DELAY SHUTTLE'S RETURN	
NEWS GUIDE BRIEFS	SPACE CENTER, HOUSTON (AP) - NASA PASSED ON ITS FIRST CHANCE TO BRING SHUTTLE ENDEAVOUR HOME FROM A RECORD-LONG JOURNEY FRIDAY BECAUSE OF BAD WEATHER AT THE FLORIDA LANDING SITE. A STORM FRONT CROSSED THE FLORIDA PENINSULA AND BROUGHT OVERCAST SKIES AND SPORADIC LIGHT RAIN, EVEN A CHANCE FOR HAIL, TO CAPE CANAVERAL, FLA. MISSION CONTROL NIXED THE FIRST LANDING ▶	
ISR-SYR TALKS TO RESUME		
KHOMAINI'S SON DEAD		
DEATH NET ACCESS BLOCKED		
YELTSIN OFFER MULLED		
LIGHTNING STRIKES CHURCH		
LOCAL WEATHER		

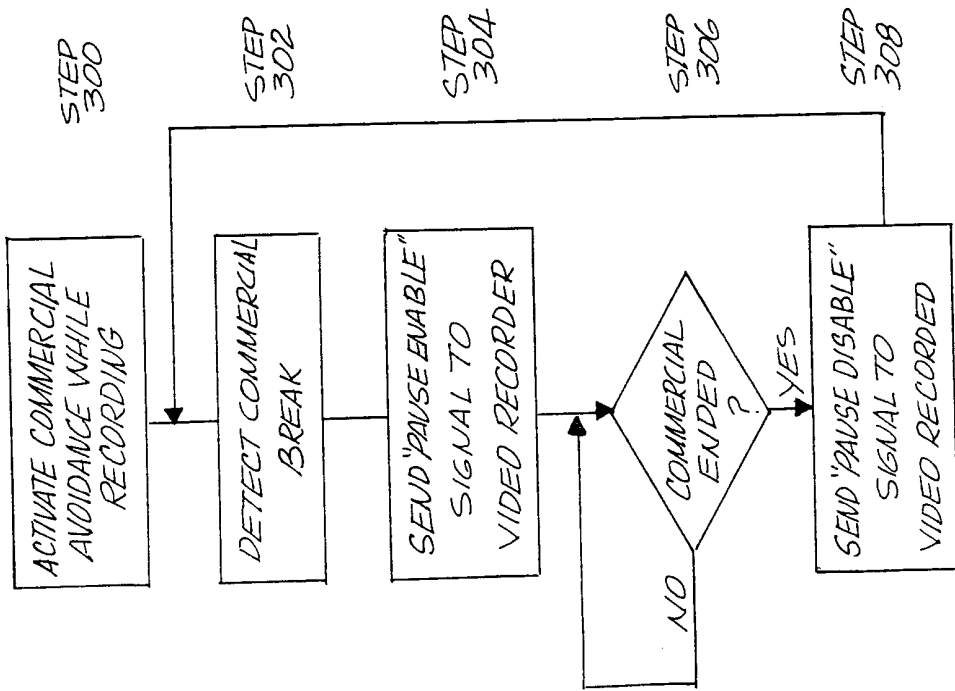

Fig. 22

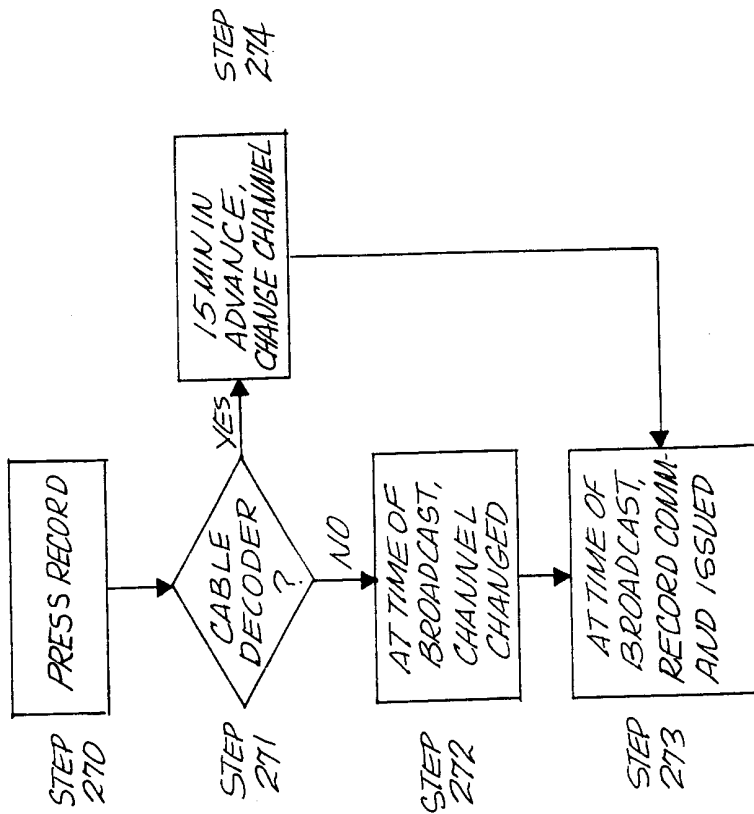
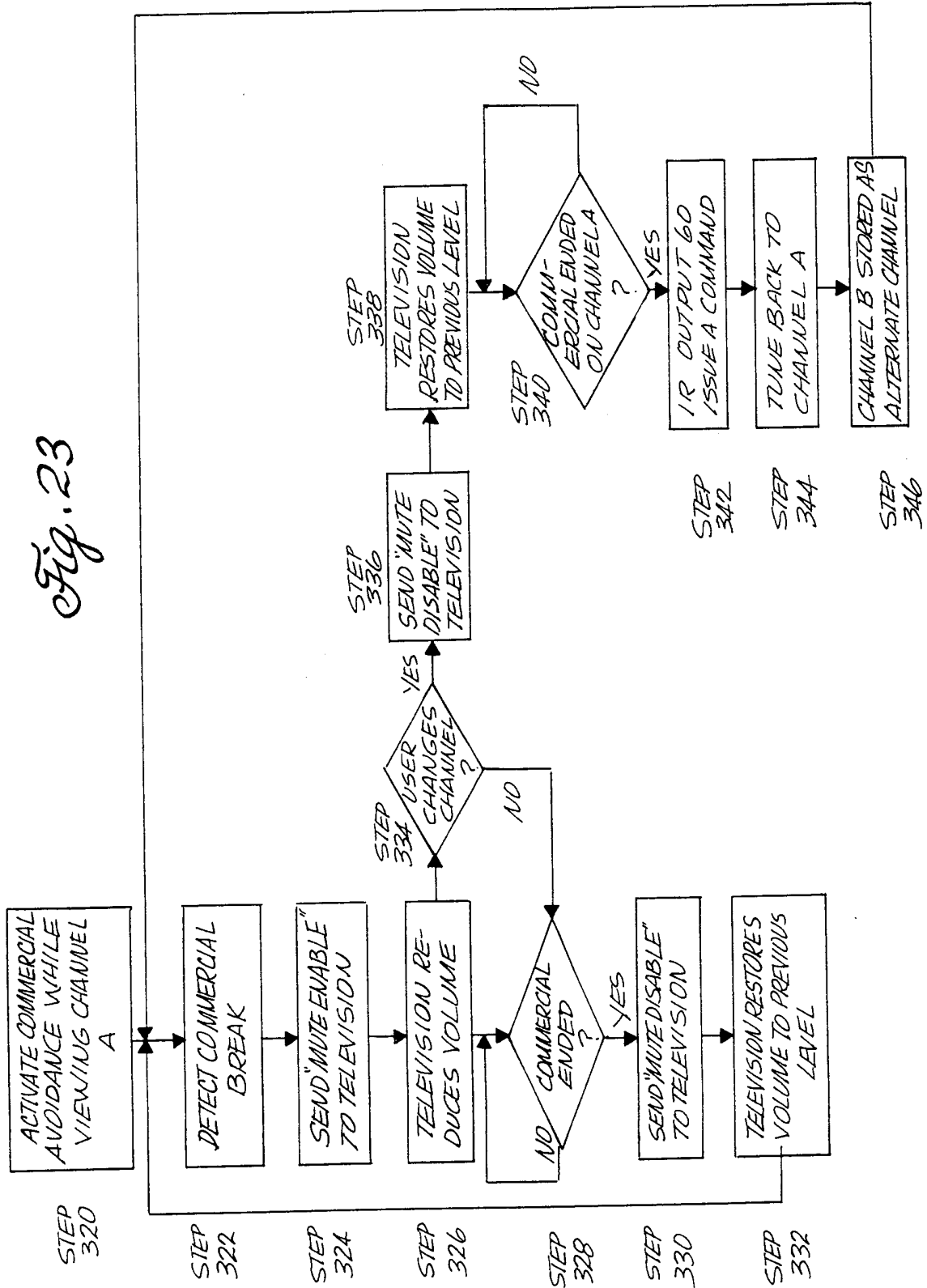

Fig. 21

Fig. 23



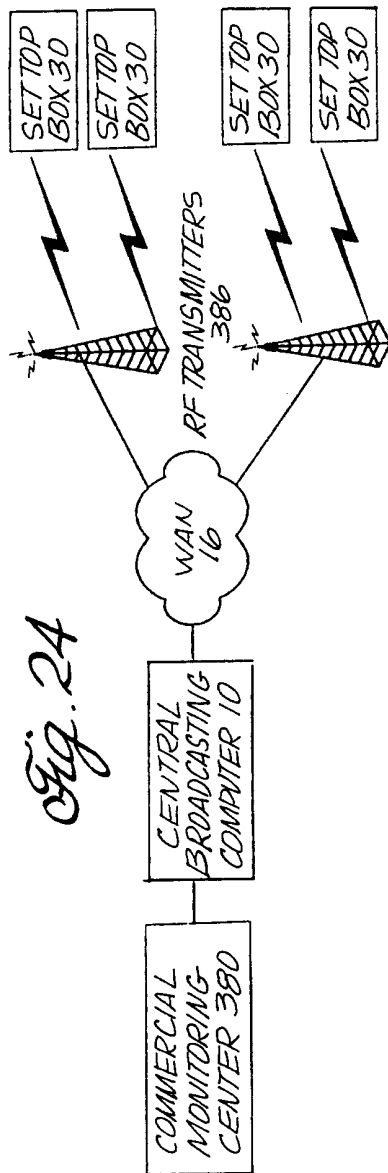

Fig. 24

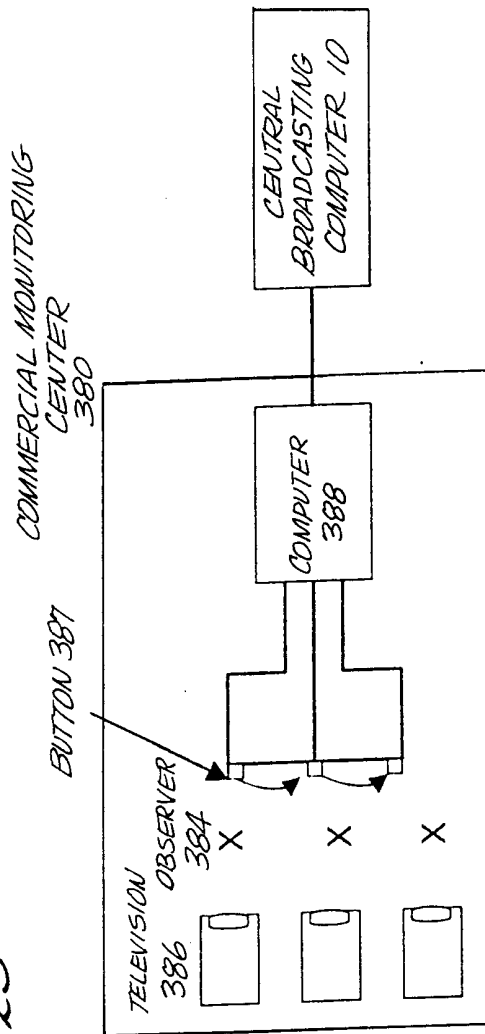

Fig. 25

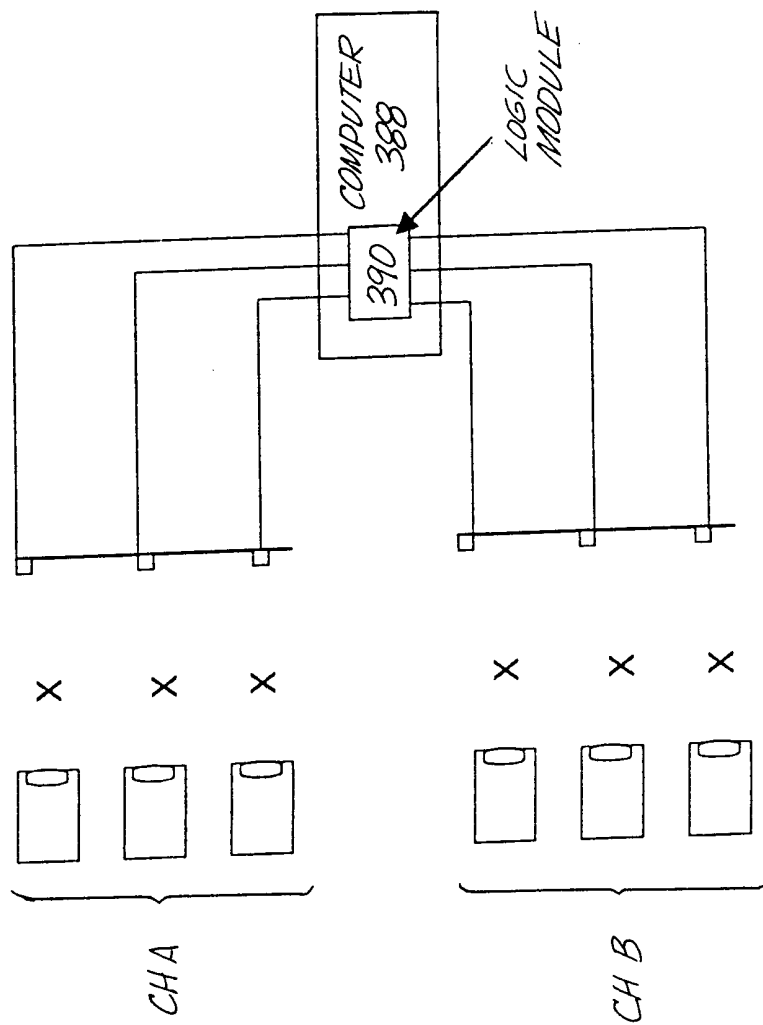
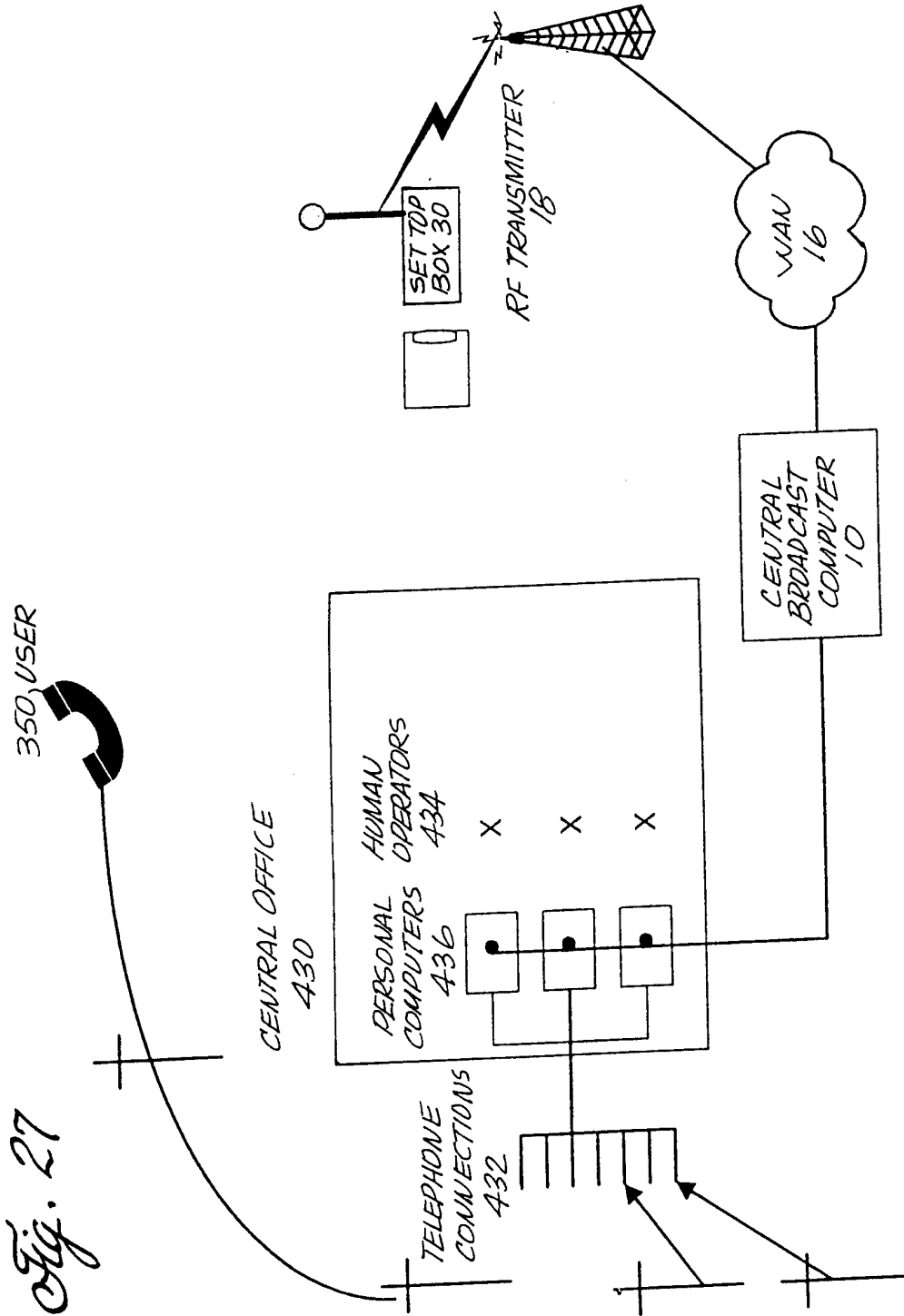

Fig. 26



INTERNATIONAL SEARCH REPORT

International application No.
PCT/US99/14545

<p>A. CLASSIFICATION OF SUBJECT MATTER IPC(6) :HO4N 7/50, 7/44 US CL :345/327; 348/569 According to International Patent Classification (IPC) or to both national classification and IPC</p>														
<p>B. FIELDS SEARCHED Minimum documentation searched (classification system followed by classification symbols) U.S. : 345/327; 348/563-569, 6-13, 731-734, 906</p> <p>Documentation searched other than minimum documentation to the extent that such documents are included in the fields searched</p> <p>Electronic data base consulted during the international search (name of data base and, where practicable, search terms used)</p>														
<p>C. DOCUMENTS CONSIDERED TO BE RELEVANT</p> <table border="1"> <thead> <tr> <th>Category*</th> <th>Citation of document, with indication, where appropriate, of the relevant passages</th> <th>Relevant to claim No.</th> </tr> </thead> <tbody> <tr> <td>X --- A</td> <td>US 5,589,892 A (KNEE ET AL) 31 December 1996, figure 1-58 (note figure 50 specifically) .</td> <td>19-25 ----- 1-18</td> </tr> <tr> <td>X --- A</td> <td>US 5,808,694 A (USUI ET AL.) 15 September 1998, figures 1-25 (note figures 22 and 25).</td> <td>11-18 ----- 1-10, 19-25</td> </tr> </tbody> </table>			Category*	Citation of document, with indication, where appropriate, of the relevant passages	Relevant to claim No.	X --- A	US 5,589,892 A (KNEE ET AL) 31 December 1996, figure 1-58 (note figure 50 specifically) .	19-25 ----- 1-18	X --- A	US 5,808,694 A (USUI ET AL.) 15 September 1998, figures 1-25 (note figures 22 and 25).	11-18 ----- 1-10, 19-25			
Category*	Citation of document, with indication, where appropriate, of the relevant passages	Relevant to claim No.												
X --- A	US 5,589,892 A (KNEE ET AL) 31 December 1996, figure 1-58 (note figure 50 specifically) .	19-25 ----- 1-18												
X --- A	US 5,808,694 A (USUI ET AL.) 15 September 1998, figures 1-25 (note figures 22 and 25).	11-18 ----- 1-10, 19-25												
<p><input type="checkbox"/> Further documents are listed in the continuation of Box C. <input type="checkbox"/> See patent family annex.</p>														
<table border="0"> <tr> <td>* Special categories of cited documents:</td> <td>*T* later document published after the international filing date or priority date and not in conflict with the application but cited to understand the principle or theory underlying the invention</td> </tr> <tr> <td>*A* document defining the general state of the art which is not considered to be of particular relevance</td> <td>*X* document of particular relevance; the claimed invention cannot be considered novel or cannot be considered to involve an inventive step when the document is taken alone</td> </tr> <tr> <td>*E* document published on or after the international filing date</td> <td>*Y* document of particular relevance; the claimed invention cannot be considered to involve an inventive step when the document is combined with one or more other such documents, such combination being obvious to a person skilled in the art</td> </tr> <tr> <td>*L* document which may throw doubts on priority claim(s) or which is cited to establish the publication date of another citation or other special reason (as specified)</td> <td>*G* document member of the same patent family</td> </tr> <tr> <td>*O* document referring to an oral disclosure, use, exhibition or other means</td> <td></td> </tr> <tr> <td>*P* document published prior to the international filing date but later than the priority date claimed</td> <td></td> </tr> </table>			* Special categories of cited documents:	*T* later document published after the international filing date or priority date and not in conflict with the application but cited to understand the principle or theory underlying the invention	*A* document defining the general state of the art which is not considered to be of particular relevance	*X* document of particular relevance; the claimed invention cannot be considered novel or cannot be considered to involve an inventive step when the document is taken alone	*E* document published on or after the international filing date	*Y* document of particular relevance; the claimed invention cannot be considered to involve an inventive step when the document is combined with one or more other such documents, such combination being obvious to a person skilled in the art	*L* document which may throw doubts on priority claim(s) or which is cited to establish the publication date of another citation or other special reason (as specified)	*G* document member of the same patent family	*O* document referring to an oral disclosure, use, exhibition or other means		*P* document published prior to the international filing date but later than the priority date claimed	
* Special categories of cited documents:	*T* later document published after the international filing date or priority date and not in conflict with the application but cited to understand the principle or theory underlying the invention													
A document defining the general state of the art which is not considered to be of particular relevance	*X* document of particular relevance; the claimed invention cannot be considered novel or cannot be considered to involve an inventive step when the document is taken alone													
E document published on or after the international filing date	*Y* document of particular relevance; the claimed invention cannot be considered to involve an inventive step when the document is combined with one or more other such documents, such combination being obvious to a person skilled in the art													
L document which may throw doubts on priority claim(s) or which is cited to establish the publication date of another citation or other special reason (as specified)	*G* document member of the same patent family													
O document referring to an oral disclosure, use, exhibition or other means														
P document published prior to the international filing date but later than the priority date claimed														
<p>Date of the actual completion of the international search 19 AUGUST 1999</p>		<p>Date of mailing of the international search report 08 NOV 1999</p>												
<p>Name and mailing address of the ISA/US Commissioner of Patents and Trademarks Box PCT Washington, D.C. 20231 Facsimile No. (703) 305-3230</p>		<p>Authorized officer NATHAN J. FLYNN <i>James R. Matthews</i> Telephone No. (703) 308-6601</p>												