

(12) UK Patent Application (19) GB (11) 2 066 365 A

(21) Application No 8041202  
(22) Date of filing 23 Dec 1980  
(30) Priority data  
(31) 54/180158U  
(32) 27 Dec 1979  
(33) Japan (JP)  
(43) Application published  
8 Jul 1981  
(51) INT CL<sup>3</sup>  
F02C 6/12 // F02B 37/00  
(52) Domestic classification  
F1G 5E2  
F1B B140 B200 B300 BA  
(56) Documents cited  
GB 1540194  
GB 1518348  
GB 1058237  
GB 982047  
US 3559397A  
(58) Field of search  
F1G  
F1T  
(71) Applicants  
Nissan Motor Company,  
Limited, No. 2, Takara-  
cho, Kanagawa-ku,  
Yokohama City, Japan  
(72) Inventor  
Ken Yamane  
(74) Agents  
Marks & Clerk, 57—60  
Lincoln's Inn Fields,  
London WC2A 3LS

(54) Turbocharger for internal combustion engine

(57) The turbine housing 11 is formed as a single unit with an exhaust guide

passage 12, a discharge passage 14, and a bypass passage 15, there being a bypass control valve 22 disposed adjacent an access hole 19 covered with a sealing member 23.

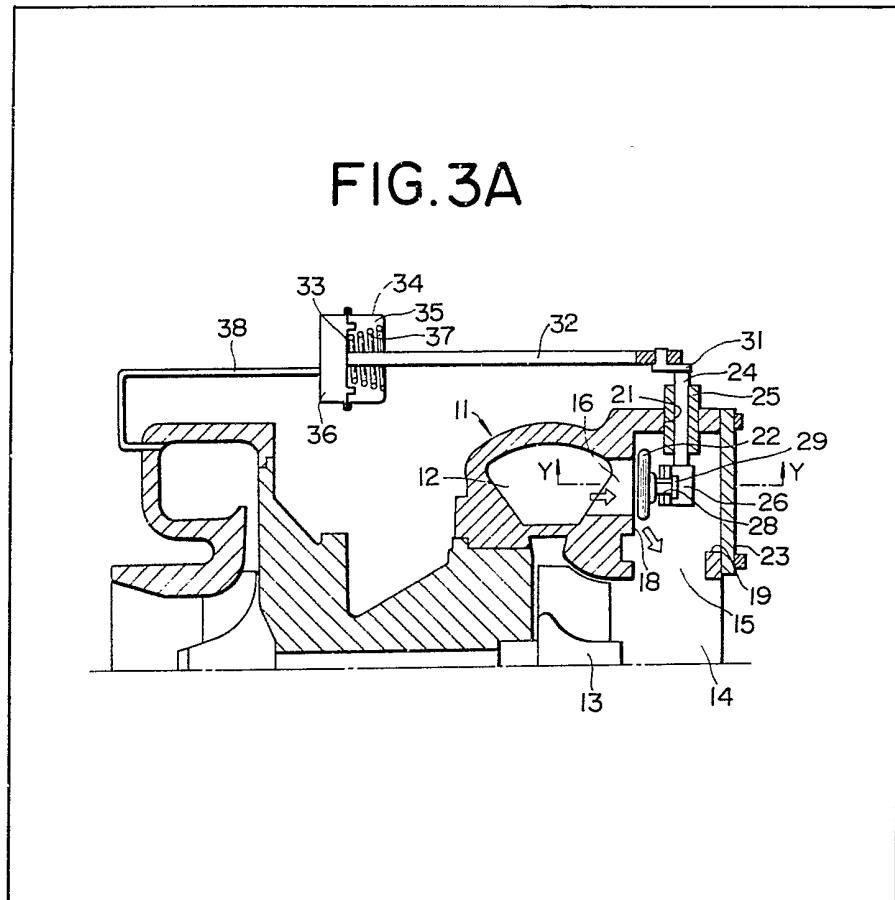

GB 2 066 365 A

1/4

FIG. 1  
(PRIOR ART)

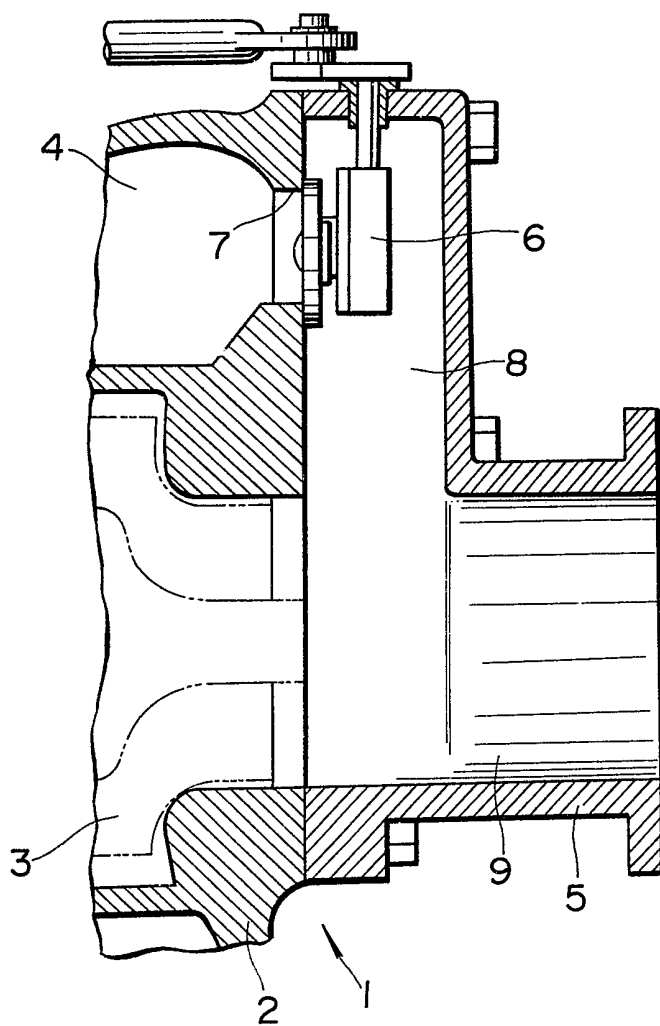

# FIG.2A

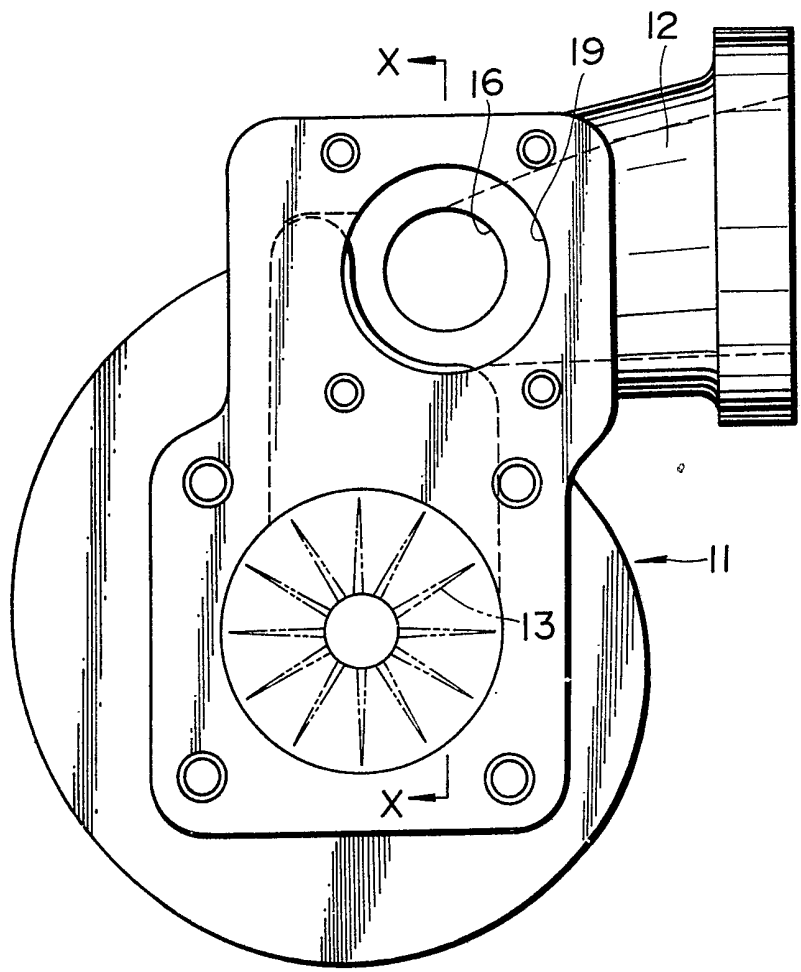

# FIG.2B

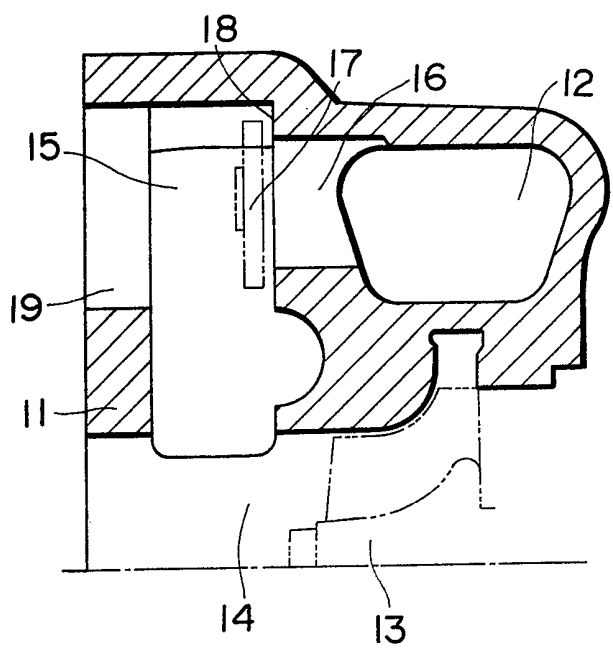

FIG. 3A

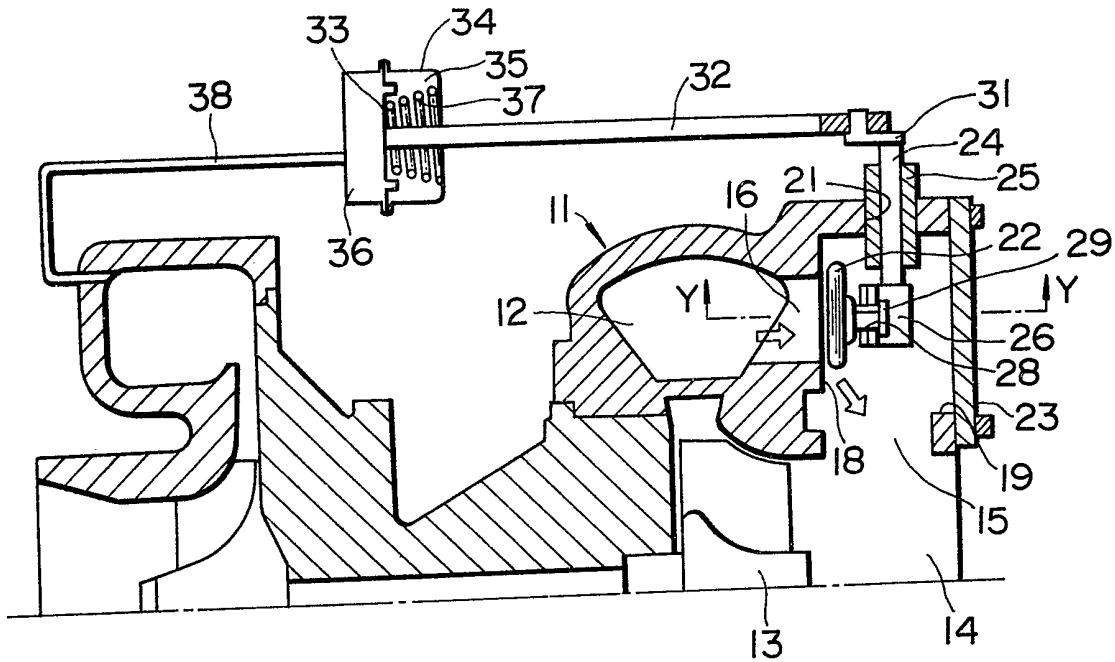
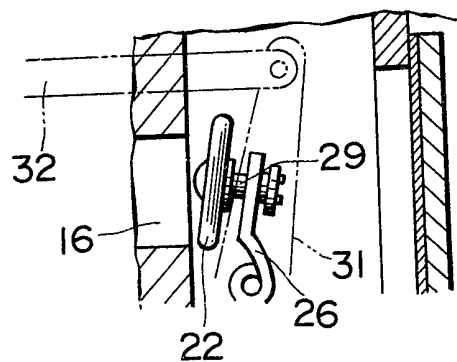
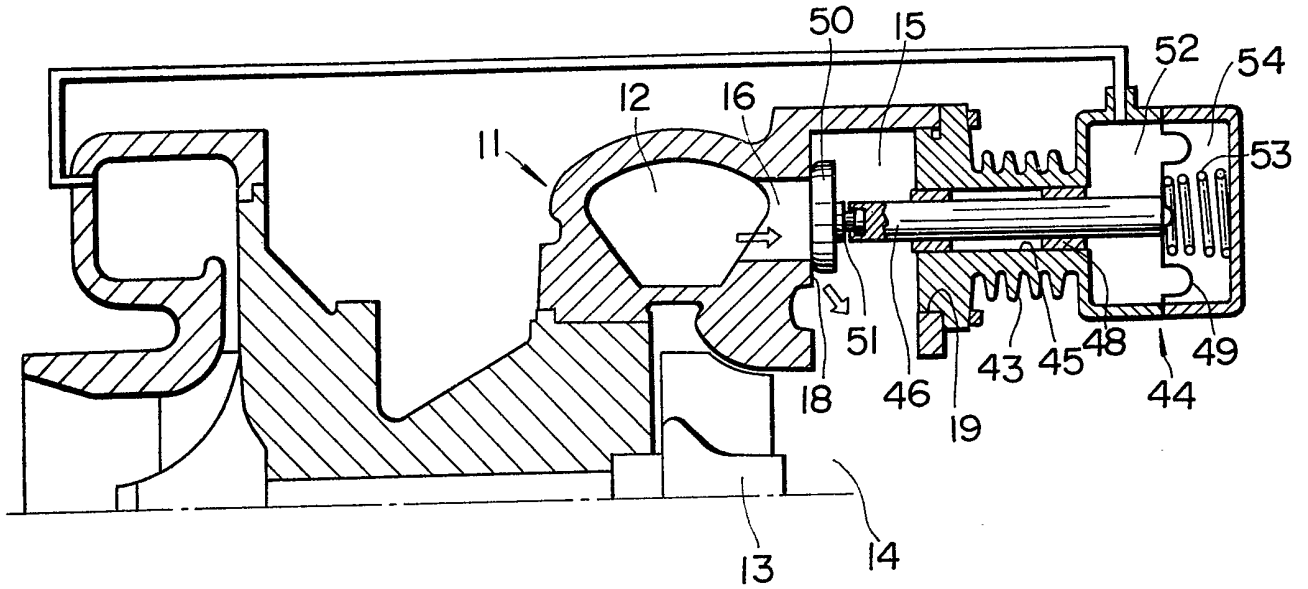

FIG. 3B



# FIG. 4



# FIG. 5

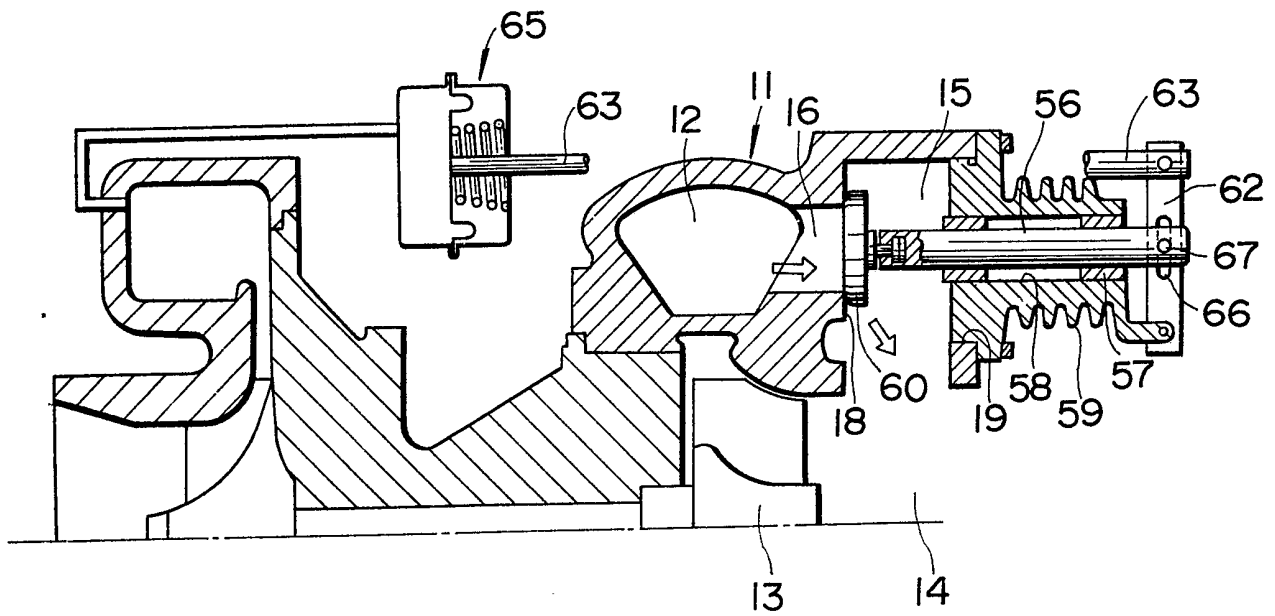

**SPECIFICATION**  
**Turbocharger for internal combustion engine**

The present invention relates generally to a turbocharger for an internal combustion engine, and more specifically to a turbocharger provided with an exhaust bypass system for preventing overspeeding of the turbine.

An exhaust bypass system is provided in a turbocharger for an internal combustion engine in order to prevent overspeeding of the turbocharger thereby to prevent an excessive increase of the output pressure of the turbocharger. This is done by leading the exhaust gas through the bypass passage bypassing the turbine of the turbocharger, when a detected pressure, such as an output pressure of the compressor or an exhaust gas pressure at the inlet of the turbine, exceeds a predetermined value at high speed of the engine.

A conventional turbine housing of such a turbocharger having an exhaust bypass passage is composed of two blocks, a main body and a housing member of an exhaust discharge part, which are bolted together. However, such a structure of a turbine housing is disadvantageous, since hot exhaust gases discharged into the bypass passage are liable to cause large thermal stress due to a non-uniform temperature distribution, which spoils the sealing between the contacting surfaces of the main body of the turbine housing and the housing member of the exhaust discharge part.

It is therefore an object of the invention to provide a turbocharger having an exhaust bypass system which is arranged to reliably prevent a leakage of exhaust gases.

According to the present invention, a turbine housing enclosing a turbine wheel of the turbocharger is made in a single block. The turbine housing of a single block is formed with an exhaust guide passage for introducing the exhaust gases from the engine to the turbine wheel, an exhaust discharge passage for discharging the exhaust gases from the turbine wheel to an exhaust pipe, and an exhaust bypass passage connecting the exhaust guide passage and the exhaust discharge passage for allowing the exhaust gases to bypass the turbine wheel. At an inlet portion of the bypass passage, there is disposed a bypass valve for regulating the flow of the exhaust gases through the bypass passage. The turbine housing is further formed with a hole at a portion of the turbine housing wall facing the valve seat of the bypass valve for giving access to enclosed parts, and this hole is airtightly covered with a sealing member.

In the accompanying drawings:—

Fig. 1 is a sectional view showing a main portion of a conventional exhaust bypass system of an exhaust turbocharger.

Fig. 2A is a side view of a turbine housing according to the present invention, and Fig. 2B is a sectional view taken along the line X—X of Fig. 2A.

Fig. 3A is a partial sectional view showing one embodiment of the present invention in which a valve of a swing type is employed as a bypass valve. Fig. 3B is a sectional view taken along the line Y—Y of Fig. 3A.

Figs. 4 and 5 are partial sectional views showing other embodiments of the present invention in which a valve of a reciprocating type is employed as a bypass valve.

Referring first to Fig. 1, a brief reference will be made to a conventional turbine housing of an exhaust turbocharger having an exhaust bypass system. In Fig. 1, a turbine housing 1 comprises a turbine housing main body 2 enclosing the periphery of a turbine wheel 3 and having therein an exhaust guide passage 4, and an exhaust outlet side member 5 having therein an exhaust bypass valve 6 disposed at a bypass inlet port 7 of an exhaust bypass passage 8 connecting the exhaust guide passage 4 with an exhaust discharge passage 9. These two turbine housing members, the turbine housing main body 2 and the exhaust outlet side member 5, are fastened together with bolts. However, such a turbocharger having a conventional design encounters a problem. When the bypass valve is open, the hot exhaust gases are discharged from the bypass inlet port 7, and spray over a portion of the exhaust outlet side member 5, causing a large temperature difference from other portions distant from the sprayed portion. This large temperature difference produces severe thermal stress which eventually reduces the sealing effectiveness in the contacting surfaces of the turbine housing main body and the exhaust outlet side member, allowing a leakage of exhaust gases therefrom.

In view of the above, a reference is now made to Figs. 2 to 5 in which the preferred embodiments of the present invention are shown.

Referring to Figs. 2A and 2B showing a turbine housing of a turbocharger according to the present invention, a turbine housing 11 has therein an exhaust guide passage 12 of a volute shape which introduces the exhaust gases from an exhaust manifold (not shown) to the periphery of a turbine wheel 13, an exhaust discharge passage 14 which leads the exhaust gases discharged from the central part of the turbine wheel, to an exhaust pipe (not shown) connected to the outer edge of the turbine housing, and an exhaust bypass passage 15 connecting the exhaust guide passage and the exhaust discharge passage *via* a bypass inlet port 16 and a bypass valve 17. These three passages are formed in the turbine housing 11 as a single unit body. In a wall of the turbine housing 11 facing a valve seat 18 of the bypass valve 17, there is formed an access hole 19 of a diameter greater than that of the bypass valve providing access to the valve seat portion to enable machining operations to be effected.

Various types of valves can be used for the bypass valve, as shown in Figs. 3 to 5. In Figs. 3A and 3B, a swing valve 22 is disposed in the turbine housing 11 and the access hole 19 has a cover 23 bolted to the outer wall of the turbine housing 11.

A top end wall of the bypass passage 15 is formed with another hole 21 through which a shaft 24 is inserted with a shaft guide 25. The shaft 24 is arranged to be rotatable around its axis. The lower end of the shaft inside the turbine housing is fixedly connected to one end of a first arm 26, and the other end of the first arm 26 is swingable around the axis of the shaft 24. The swingable end of the first arm 26 has a small hole 28, through which a pin 29 of the swing valve 22 is fitted with a clearance for enabling free play to some extent so that the swing valve 22 is loosely supported.

The outer end of the shaft 24 outside the turbine housing is fixedly connected to one end of a second arm 31. The other end of the second arm 31 is swingable and connected with one end of a rod 32, the other end of which is connected to a diaphragm 33 of a diaphragm actuator 34. The diaphragm actuator 34 has therein two chambers, an air chamber 35 formed on the side of the rod 32 and a control chamber 36 formed on the other side of the diaphragm 33. The air chamber 35 communicates with atmosphere and has therein a compression spring 37. The control chamber 36 is connected with the intake air outlet side of the turbocharger compressor through a conduit 38 and thus the output pressure (supercharge pressure) of the turbocharger is introduced to the control chamber of the diaphragm actuator. The diaphragm is arranged to deflect to the right in Fig. 3 together with the rod 32 connected to the diaphragm, against the force of the compression spring 37 when the output pressure of the turbocharger exceeds a predetermined value. Then the second arm 31 is pivoted on the axis of the shaft 24, causing the shaft 24 and the first arm 26 to rotate together. Consequently, the swing valve 22 swings rightwards and opens the bypass inlet port 16, allowing a portion of the exhaust gases to flow through the bypass passage 15. Thus the opening of the bypass valve 22 is determined by the balance between the output pressure of the turbocharger and the force of the compression spring 37. The output pressure of the turbocharger is controlled by regulating the opening of the bypass valve 22 in this way.

Between the swing valve 22 and the first arm 26, there is play resulting from the loose connection therebetween, and the mating surfaces of the valve head 22 and the valve seat 18 are flat, so that the valve can tightly fit with the valve seat to close the valve and accomplish its functions sufficiently, even though there are dimensional errors, for example, a misalignment of the valve head and the bypass inlet port, resulting from machining or assembly processes.

The cover 23 need not have a larger diameter than needed to cover the access hole 19, and receives uniformly the hot exhaust gases splashed into the bypass passage. Therefore the temperature distribution in the blind cover is uniform, so that thermal stress hardly arises. Thus this arrangement provides a satisfactory sealing in the contacting surfaces of the cover and the turbine housing, and prevents reliably a leakage of

the exhaust gases from the contacting interface.

In the embodiment shown in Fig. 4, the bypass valve is supported by a shaft inserted through the access hole 19. An end portion of a valve guide 43 of the diaphragm actuator 44 is airtightly fitted into the access hole 19 and thus fastened to the turbine housing 11. In the valve guide 43, there is formed a bore 45 extending parallel to the axis of the turbine, and a shaft 46 is inserted through the bore 45 of the valve guide 43 with a bushing 48 so that the shaft 48 is axially slidable. The shaft 46 is connected at one end thereof with the diaphragm 49 and the other end of the shaft 46 inside the turbine housing is linked with a plate valve head 50 by means of a universal coupling 51. With this arrangement, the opening of the bypass valve is determined by the balance between the output pressure of the turbocharger introduced into the control chamber 52 of the diaphragm actuator 44 and the force of the compression spring 53 disposed in the air chamber 54. Thus the flow rate in the bypass passage 15 is controlled to control the output pressure of the turbocharger.

In this embodiment, the sealing effectiveness is improved because there is no need to provide another hole in the turbine housing wall for the valve guide. The universal coupling 51 supporting the valve head provides a flexible fitting between the valve head and the valve seat even if there are dimensional errors, such as a misalignment between the valve head 50 and the exhaust bypass inlet port 16 or an inclination of the shaft 46.

Fig. 5 shows another embodiment which is different from the embodiment shown in Fig. 4 in the position of the diaphragm actuator. Like the embodiment of Fig. 4, a shaft 56 is guided by a bushing 57 and inserted through a bore 58 of a valve guide 59 fitted into the access hole 19 of the turbine housing 11, and a valve head 60 is linked with the inner end of the shaft. One end of a lever 62 is pivotally supported by a portion of the valve guide 59 and the other end of the lever 62 is pivotally connected with one end of a rod 63 of a diaphragm actuator 65 having the same construction as the diaphragm actuator 44 of Fig. 4. In the middle portion of the lever 62, there is formed a slit 66, into which a pin 67 fixed to the outer end of the shaft 56 is engaged. With this arrangement, when the output pressure of the turbocharger increases, the rod 63 moves to the right, causing the swingable end of the lever 62 to swing clockwise, so that the shaft 56 is moved to the right to open the bypass valve, while the pin 67 of the shaft 56 slides along the slit 66. The longitudinal direction of the slit 66 is perpendicular to the axis of the shaft 56 when the valve is closed, so that bending stress is not exerted on the shaft through the pin 67.

When the exhaust gas temperature is high or when there is little space around the turbine housing, it is convenient to locate the actuator spaced from the turbine as in Fig. 3 or 5. If the exhaust gases include very harmful components, a

valve of a reciprocating type, as in Figs. 4 and 5, is advantageous because of its improved sealing effectiveness. If the exhaust gases include viscous material, the shaft of a reciprocating type valve is liable to stick and therefore a swing valve of Fig. 3 is preferable. If the exhaust gases include dry fine particles, a valve of a reciprocating type is preferable because of its self cleaning action.

According to the present invention, the exhaust guide passage, the exhaust discharge passage and the exhaust bypass passage are formed in the turbine housing of a single block, and the access hole which is bored in a portion of the turbine housing facing the bypass valve seat for providing access to the valve seat portion to enable machining operations to be effected, is sealed with a sealing member. Therefore, when the bypass valve is open, the hot exhaust gases uniformly spray over the sealed portion of the turbine housing. Besides, because the area of the sealing member is small, the temperature distribution of the sealing member is maintained uniform, so that the sealing effectiveness is improved. Thus the heated portion of the bypass passage exposed directly to the hot exhaust gases is not deformed substantially and therefore bypass valves of various types can be disposed at that portion of the bypass passage. When the access hole of the turbine housing is sealed with the valve guide member of the bypass valve, as one embodiment of the present invention, the construction is simplified, reducing the number of places to be sealed and eliminating some steps of assembly process.

Although the bypass valve is controlled in response to the output pressure of the turbocharger in the embodiments mentioned above, it is optional to control the bypass valve in response to the exhaust pressure at the inlet of the turbine.

#### CLAIMS

1. A turbocharger for an internal combustion engine, said turbocharger comprising:

a compressor for compressing the intake air for the engine, and

a turbine driven by the force of the exhaust gases from the engine for driving said compressor, said turbine comprising:

a turbine wheel,

a turbine housing enclosing said turbine wheel, said turbine housing being formed with an exhaust guide passage for introducing the exhaust gases from the engine to said turbine wheel, an exhaust discharge passage, and an exhaust bypass

passage connecting said exhaust guide passage and said exhaust discharge passage for allowing

the exhaust gases to bypass said turbine wheel, and

a bypass valve disposed at an inlet portion of said bypass passage for regulating the flow of the exhaust gases through said bypass passage,

said turbine housing being made as a single block and being formed with a hole at a portion of the turbine housing wall facing a seat portion of said bypass valve for providing access to the seat portion of said bypass valve, said hole being airtightly covered with a sealing member.

2. The turbocharger as in Claim 1, further comprising a valve actuator linked with said bypass valve for actuating said bypass valve.

3. The turbocharger as in Claim 2, wherein said bypass valve is a valve of a swing type having a rotatable shaft for swinging a valve head around the axis of said shaft, and wherein said sealing member is a plate.

4. The turbocharger as in Claim 2, wherein said valve actuator is a diaphragm actuator having a diaphragm as a partition between a control chamber into which the output pressure of the turbocharger is introduced and an air chamber communicating with atmosphere, and a compression spring disposed in said air chamber for biasing said diaphragm toward said control chamber against the pressure in said control chamber, said diaphragm being linked with said bypass valve for opening said bypass valve when the output pressure of the turbocharger exceeds a predetermined value.

5. The turbocharger as in Claim 2, wherein said bypass valve of a reciprocating type having a reciprocating shaft for moving a valve head axially in the direction at right angles to the plane of its valve seat, and wherein said sealing member is a valve guide having a bore through which said reciprocating shaft is inserted.

6. The turbocharger as in Claim 5, wherein said diaphragm actuator is fasten to said guide and said reciprocating shaft is directly linked with said diaphragm.

7. The turbocharger as in Claim 5, wherein said diaphragm actuator is separate from said valve guide, said valve guide having a lever pivoted on one end, the other end of which is pivotally connected to a rod connected to said diaphragm, said lever having at a middle portion thereof a slit slidably receiving an end portion of said reciprocating shaft thereby transmitting the movement of said diaphragm to said reciprocating shaft.

8. A turbocharger for an internal combustion engine substantially as described with reference to, and as illustrated in Figs. 2A to 3B, or Fig. 4, or Fig. 5, of the accompanying drawings.