

Aug. 17, 1954

H. R. FISHER  
CARTON AND CASE CUTTER

2,686,360

Filed Dec. 6, 1952

2 Sheets-Sheet 1

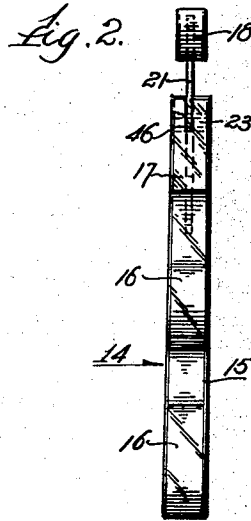
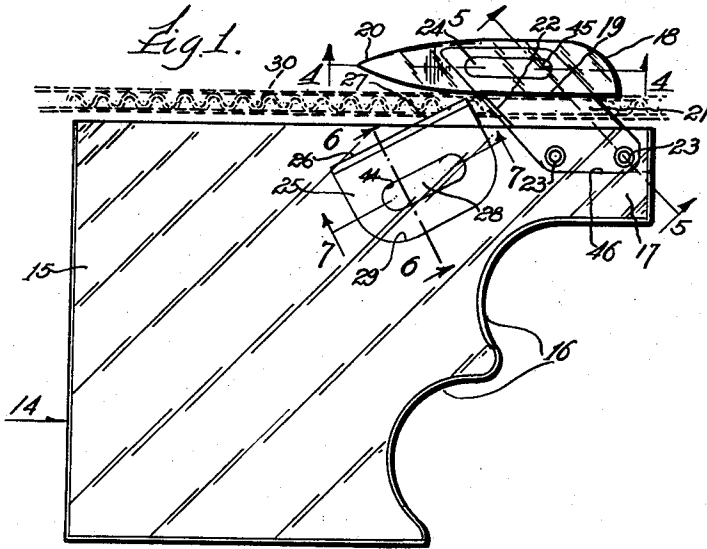

Fig. 3.

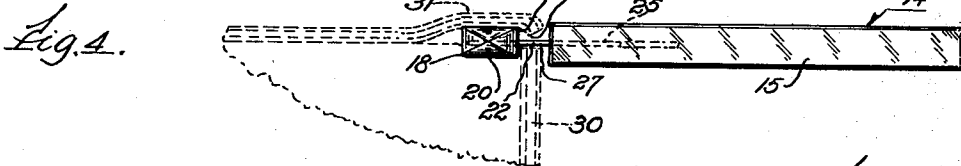

Fig. 4.

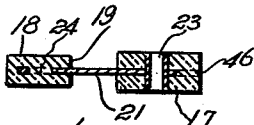

Fig. 5.

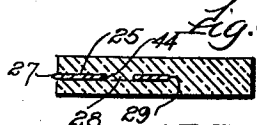

Fig. 6.

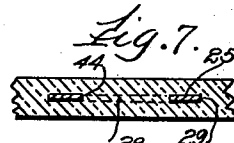

Fig. 7.

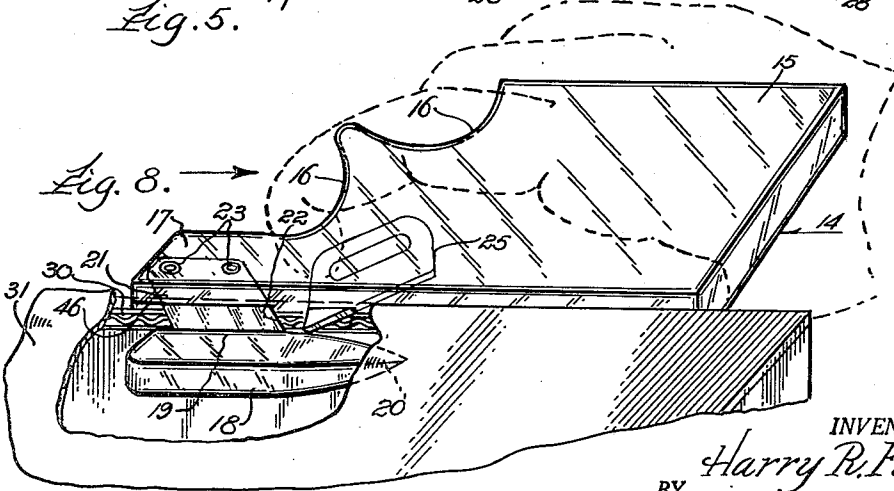

Fig. 8.

INVENTOR.  
*Harry R. Fisher.*  
BY *David W. J. Heller.*  
Attorney.

Aug. 17, 1954

H. R. FISHER  
CARTON AND CASE CUTTER

2,686,360

Filed Dec. 6, 1952

2 Sheets-Sheet 2

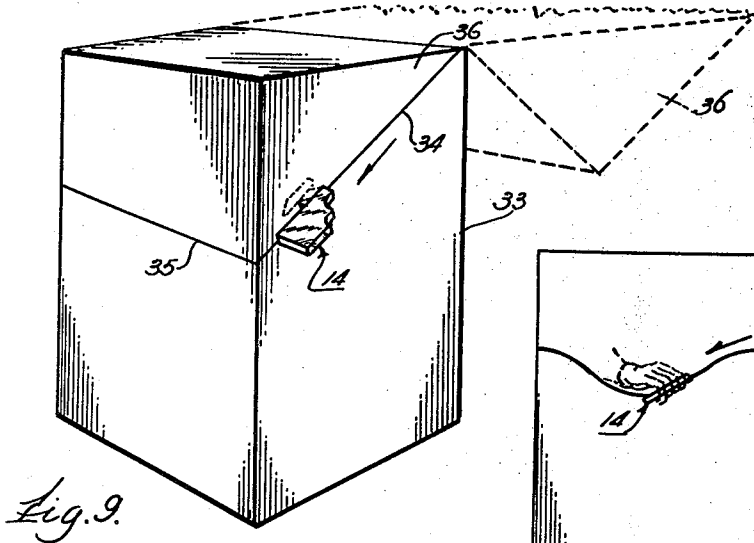

Fig. 9.

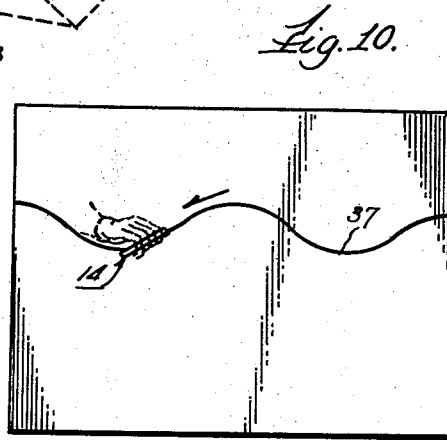

Fig. 10.

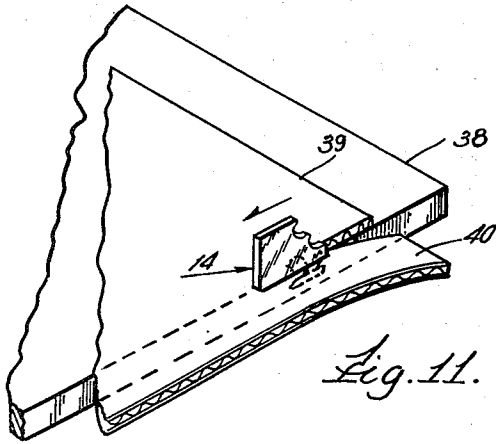

Fig. 11.

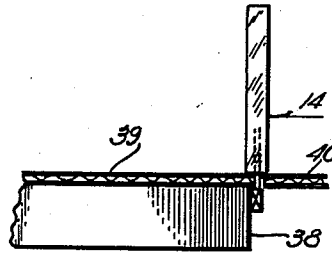

Fig. 12.

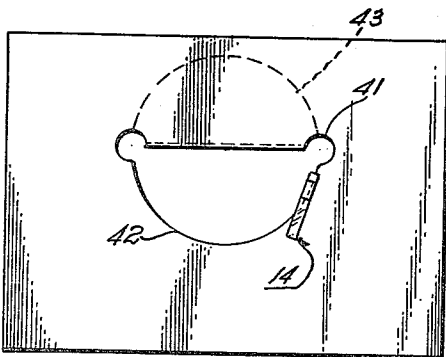

Fig. 13.

INVENTOR.  
*Harry R. Fisher.*  
 BY  
*David W. Hester,*  
 Attorney.

# UNITED STATES PATENT OFFICE

2,686,360

## CARTON AND CASE CUTTER

Harry R. Fisher, Park Forest, Ill.

Application December 6, 1952; Serial No. 324,520

6 Claims. (Cl. 30—2)

1

My invention relates to cutting devices which are used primarily for cutting cartons, corrugated cases and like containers.

An important object of my invention is to provide a cutting device of the aforementioned character, which is equipped with pilot or guide means, which may be introduced into a corner opening of the carton or corrugated case to be opened, and used as a guide interiorly of the case while the cutting operation takes place as the device is manipulated across an edge of the carton or case.

Another object of my invention is to provide a cutting device of the aforementioned character equipped with oblique cutting means, disposed to effectuate bias cutting actions in contra directions.

A further object of my invention is to provide a cutting device of the aforementioned character which is adaptable for other uses and cutting operations.

A still further object of my invention is to provide a device of the aforementioned character, which may be utilized for cutting sectional portions of cartons or corrugated cases or packages.

A still further object of my invention is to provide a cutter which may be utilized for cutting sections of corrugated material, leather and like substances.

A still further object of my invention is to provide in a device of the aforementioned character, leading shearing cutter means operating in concert with follower cutter means to completely sever a wall of a corrugated container.

A still further object of my invention is to provide a device of the aforementioned character which will protect and not damage the contents of a container when it is utilized to sever a wall thereof.

A still further object of my invention is to provide a cutting device of the aforementioned character which is simple in its construction, practical for the purposes for which it may be utilized, and of such simple elemental construction as to permit economical manufacture thereof in quantity production.

Other objects and advantages inherent in my invention will become apparent from an examination of the accompanying drawings, bearing further elucidation in the ensuing description, wherein like symbols are used to designate like parts, and in which;

Fig. 1 is a top view of my invention, showing the same inserted behind the wall of a carton preparatory to performing the slitting or cutting operation.

2

Fig. 2 is an end view of Fig. 1.

Fig. 3 is an end view looking at the left of Fig. 1, the view being oriented 90°.

Fig. 4 is a fragmentary, cross-sectional view taken, substantially, on the lines 4—4 of Fig. 1.

Fig. 5 is a cross-sectional view taken, substantially, on the lines 5—5 of Fig. 1.

Fig. 6 is a fragmentary, cross-sectional view taken, substantially, on the lines 6—6 of Fig. 1.

Fig. 7 is a cross-sectional view taken, substantially, on the lines 7—7 of Fig. 1.

Fig. 8 is a perspective view similar to that indicated, or illustrated, in Fig. 1, showing the fragmentary section of a closed corrugated case or carton, and indicating the relative positions of the operating elements of my invention in the process of being guided along to perform the slitting or cutting operation of a wall of the said corrugated case or carton.

Fig. 9 is a perspective view of a carton showing another use of my invention, whereby it may be manipulated to cut along oblique lines in order to sever and form a hinged cover for a container.

Fig. 10 shows another cutting operation, indicating a sinuous type of cut performed in a carton with my cutting device.

Fig. 11 is a perspective view showing my invention utilized for cutting off segmental strips of material.

Fig. 12 is an end view of Fig. 11.

Fig. 13 indicates another operation which may be performed with my invention, namely, cutting out and forming reinforcing carrying handles for cartons or like containers.

Referring to the various views, my invention is generally designated 14, and consists of a substantially rectangular handle element 15, which, in this instance, is indicated as being made of transparent plastic material. The handle, however, may be made of any other type of molding material. In this handle there is a cut-out portion 16, to fit the index and middle finger of the hand, so that the hand can wrap itself around conveniently about the handle element 15, when engaged in using the device for cutting operations.

In the molding of the handle element 15, the leading cutting blade 25 is placed in the mold, forming its own recess 29, and inasmuch as the blade is provided with an elongated, slotted portion 44, the molding operation will effectuate a rigid locating web, 28, in the plastic material, which will maintain the blade 25 and its cutting edge 26 firmly embedded, and in angular or oblique cutting relationship with the exposed cutting edge portion 27.

The pilot element 18, which is also utilized

for gauging the activity of the cutter by virtue of its gauging edge 19, is provided also with a pilot portion 20, which is pointed or pyramidal in construction. The said pilot element 18 is also made of moldable material, and the follower oblique cutter 21 is placed in the mold so that it will be rigidly embedded in the pilot element 18, and inasmuch as this is provided with an elongated slot 45, a web 24 will be formed, which will rigidly secure the cutter element 21 to the pilot element 18.

The cutter element 21, or the follower cutter element 21, is substantially of parallelogrammic configuration, and has an extended portion which will be secured to a slotted portion 46, formed in the ledge 17 of the handle element 15, the same being assembled in the proper relationship indicated in Fig. 1 by virtue of grommets 23.

It will be noted that the cutting edge portion 27, and the cutting edge portion 22 are arranged in contra oblique directions in order to effectuate compositely a complete cut through the thickness of the carton 30.

The operation of the instrumentality is rather simple. The device is grasped in the hand as illustrated in Fig. 8. The pilot 20 is inserted into a corner 32 of the carton 30, (see Fig. 3). The device is then manipulated across the edge of a carton 30, and below the cover 31, with the gauging edge 19 against the inner wall of the carton section to be cut, and as the device is slid along in the direction shown by the arrow in Fig. 8, the greater portion of the carton section will be severed by the cutting edge 27, and the operation will be completed by the cutting edge 22 working from the inner confines of the container. Thus, a complete dual contra bias cutting action takes place to effectuate a clean cut.

The carton may be cut to any suitable shape, as well as merely for opening to remove the contents.

I wish to stress that one of the important features of my invention is the fact that the pilot 20 permits the cutting operation to be initiated even with the most tightly glued or closed cartons, and by virtue of the inner gauging edge 19 of the pilot 18, no damage is caused to the contents of the carton, inasmuch as the cutting operation is effectuated with an action that tends to hold the cutting blade and the pilot away from the inner confines of the carton to protect the commodities or objects therein.

The item comprising my invention 14 may also be utilized for other purposes, as illustrated in Figs. 9-13.

In Fig. 9 a carton 33 may be severed by cutting along the lines 34 and 35 in order to form a suitable display for the contents therein. The cover 36 may be folded backward, as shown in dotted lines, and then utilized for effecting a complete closure of the carton 33.

Likewise, sinuous cuts or decorative cuts, as indicated in Fig. 10 and designated 37, may be accomplished, with proper or slight manual dexterity in the handling of the carton cutter generally designated 14.

The instrumentality may also be utilized as indicated in Figs. 11 and 12, for cutting sections or segments 40 of corrugated board material 39, leather or other substances, against a guiding edge on a cutting board 38.

It may also be utilized as indicated in Fig. 13, after first forming two piercing openings 41 to permit the pilot 18 to be inserted, the device may then be manipulated along the line 42, cut-

ting out a section which may be folded back to form a reinforcing carrying handle 43 for cartons or containers.

In general, my device is of a simple construction, and it can be utilized to effectuate a cutting of cartons, corrugated cases, pasteboard boxes and like containers without damaging the contents therein.

It will also be noted that my device is of a simple construction, can be conveniently held in the hand, and manipulated to effectuate the various operations outlined in the drawings accompanying this application.

While the invention has been herein described in its preferred form it is to be understood that it is not limited to the specific construction herein shown and that it may be practiced in other forms without departing from the spirit and scope thereof.

Having thus described and revealed my invention, what I claim as new and desire to secure by Letters Patent is:

1. Carton and case cutter means, comprising a substantially rectangular handle element, leading cutter means secured to the said handle element in cutting position oblique to the line of movement, pilot means, and follower cutter means securing the said pilot means to the said handle element and defining a guideway between the said pilot means and the said handle element for the material to be cut, the said follower cutter means completing the cutting operation initiated by the said leading cutter means.

2. Carton and case cutter means, comprising a substantially rectangular handle element, leading cutter means secured to the said handle element in cutting position oblique to the line of movement, pilot means, and follower cutter means disposed in contra cutting position oblique to the line of movement securing the said pilot means to the said handle element and defining a guideway between the said pilot means and the said handle element for the material to be cut, the said follower cutter means completing the cutting operation initiated by the said leading cutter means.

3. Carton and case cutter means, comprising a substantially rectangular handle element, leading cutter means secured to the said handle element in cutting position oblique to the line of movement, pilot means, and follower cutter means securing the said pilot means to the said handle element and defining a guideway between the said pilot means and the said handle element for the material to be cut, the said follower cutter means completing the cutting operation initiated by the said leading cutter means, the said pilot means being provided with a pointed pilot portion.

4. Carton and case cutter means, comprising a substantially rectangular handle element, leading cutter means secured to the said handle element in cutting position oblique to the line of movement, pilot means, and follower cutter means disposed in contra cutting position oblique to the line of movement securing the said pilot means to the said handle element and defining a guideway between the said pilot means and the said handle element for the material to be cut, the said follower cutter means completing the cutting operation initiated by the said leading cutter means, the said pilot means being provided with a pointed pilot portion.

5. Carton and case cutter means, comprising

5

a substantially rectangular handle element, leading cutter means secured to the said handle element in cutting position oblique to the line of movement, pilot means, and follower cutter means securing the said pilot means to the said handle element and defining a material guideway between the said pilot means and the said handle element for the material to be cut, the said follower cutter means completing the cutting operation initiated by the said leading cutter means, the said pilot means being provided with a pointed pilot portion, the said pilot means being further provided with a guiding edge to guide the said carton and case cutter means to prevent damage to the contents of a carton being cut.

6. Carton and case cutter means, comprising a substantially rectangular handle element, leading cutter means secured to the said handle element in cutting position oblique to the line of movement, pilot means, and follower cutter means disposed in contra cutting position

6

oblique to the line of movement securing the said pilot means to the said handle element and defining a guideway between the said pilot means and the said handle element for the material to be cut, the said follower cutter means completing the cutting operation initiated by the said leading cutter means, the said pilot means being provided with a pointed pilot portion, the said pilot means being further provided with a guiding edge to guide the said carton and case cutter means to prevent damage to the contents of a carton being cut.

## References Cited in the file of this patent

## UNITED STATES PATENTS

Number	Name	Date
521,115	Hopper -----	June 5, 1894
765,391	Long -----	July 19, 1904
1,594,963	James -----	Aug. 3, 1926
2,238,678	Cook -----	Apr. 15, 1941
2,537,505	Baran -----	Jan. 9, 1951