



US 20120199158A1

(19) **United States**

(12) **Patent Application Publication**  
**Bickford**

(10) **Pub. No.: US 2012/0199158 A1**

(43) **Pub. Date: Aug. 9, 2012**

(54) **COMPRESSIBLE COSMETIC APPLICATOR**

**Publication Classification**

(76) Inventor: **William Robert Bickford,**  
Ronkonkoma, NY (US)

(51) **Int. Cl.**  
*A45D 40/26* (2006.01)

(21) Appl. No.: **13/448,008**

(52) **U.S. Cl.** ..... **132/218**

(22) Filed: **Apr. 16, 2012**

(57) **ABSTRACT**

**Related U.S. Application Data**

(62) Division of application No. 12/765,007, filed on Apr. 22, 2010, now Pat. No. 8,191,559.

(60) Provisional application No. 61/179,277, filed on May 18, 2009.

An applicator head for cosmetic products such as mascara is described. The applicator head has three arched supports, each with and outwardly directed applicator surface. The arched supports surround a clearance and define a relatively large, expanded configuration for loading and application purposes. The arched supports flex inwardly, into the clearance, so that the expanded configuration can collapse to permit the applicator head to be drawn through a relatively smaller wiper opening. The applicator head can be used in stock packaging.

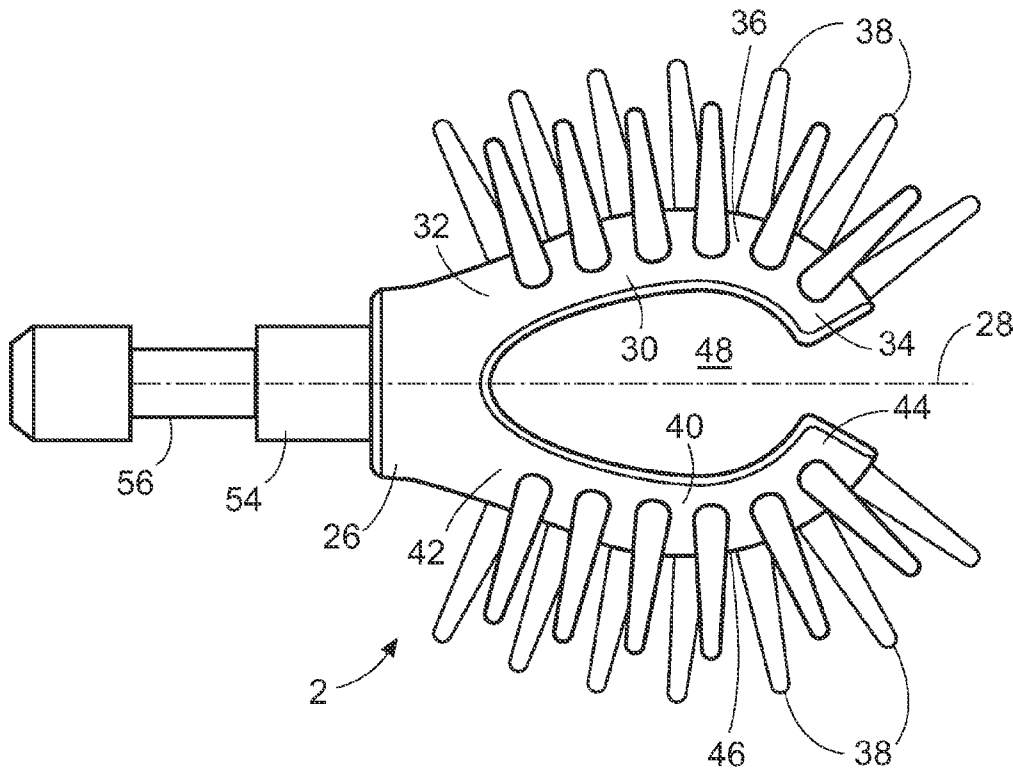

FIG. 1

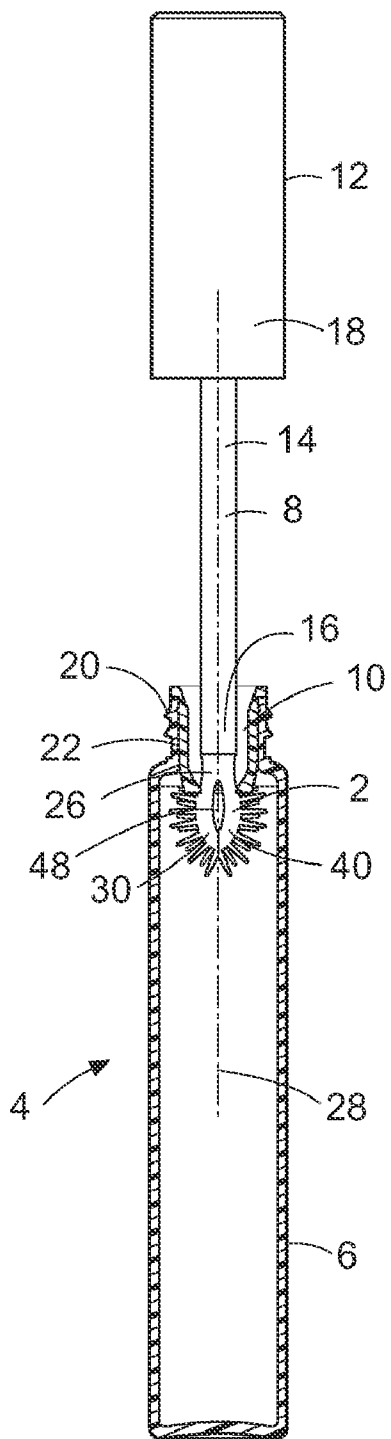

FIG. 2

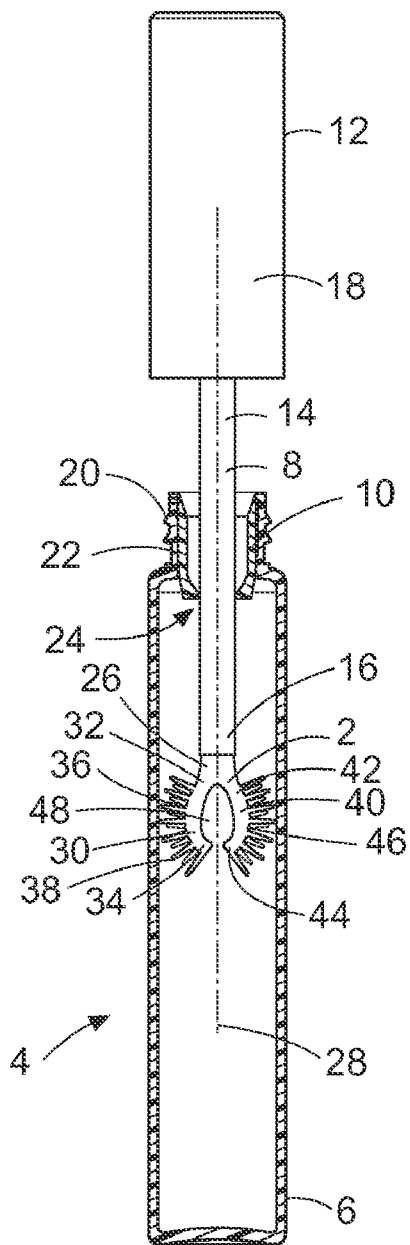

FIG. 3

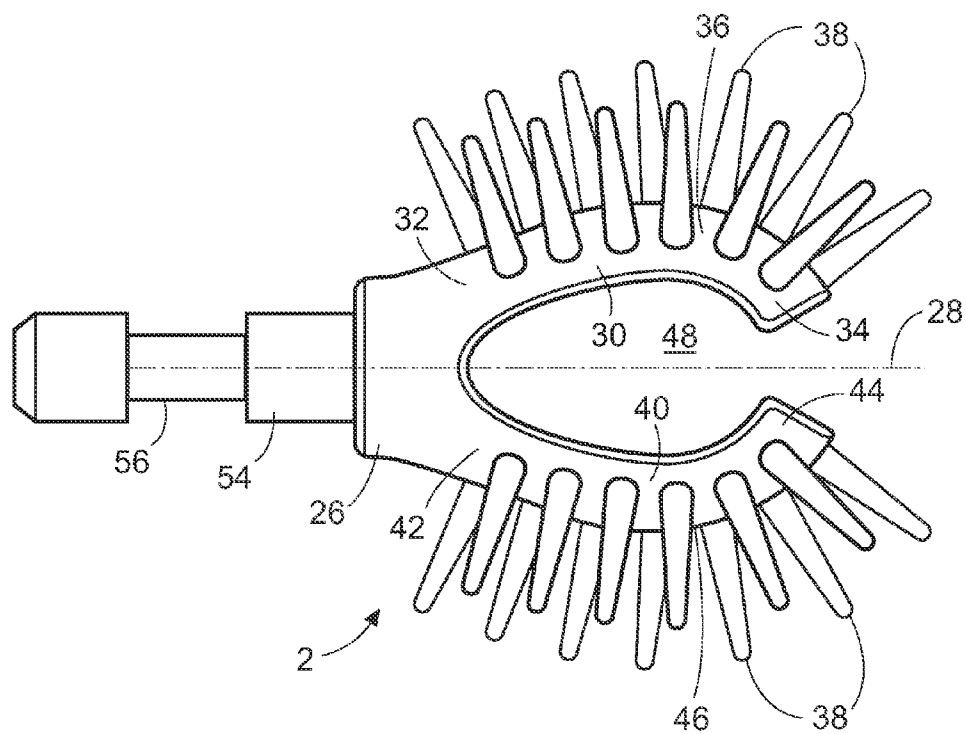

FIG. 4

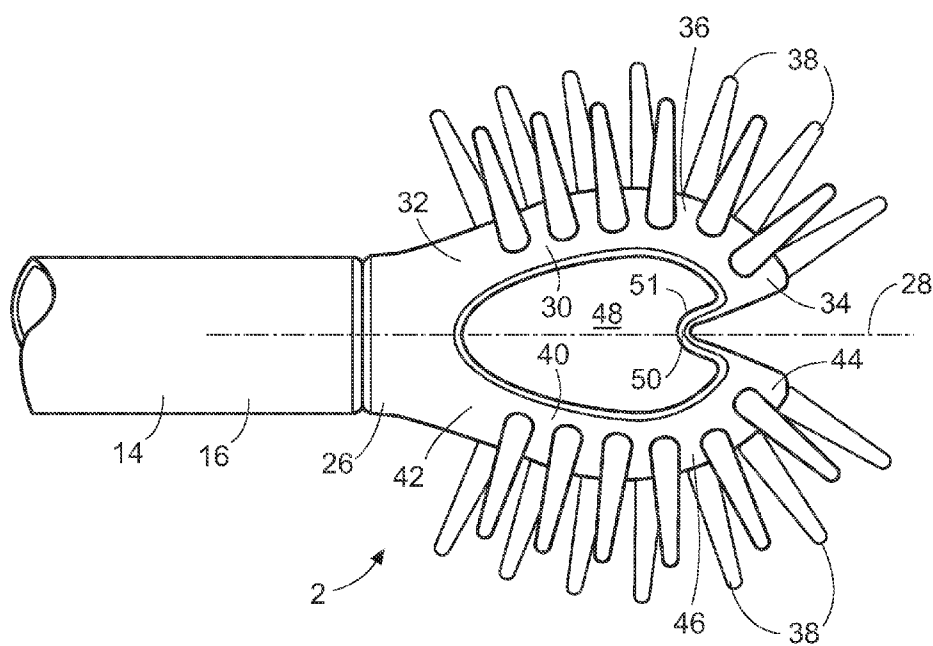
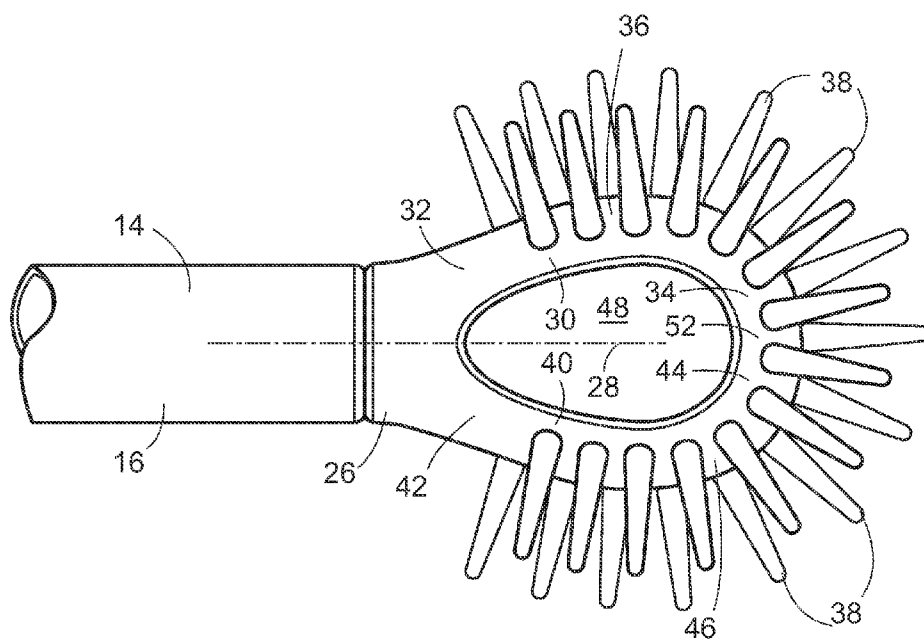

FIG. 5



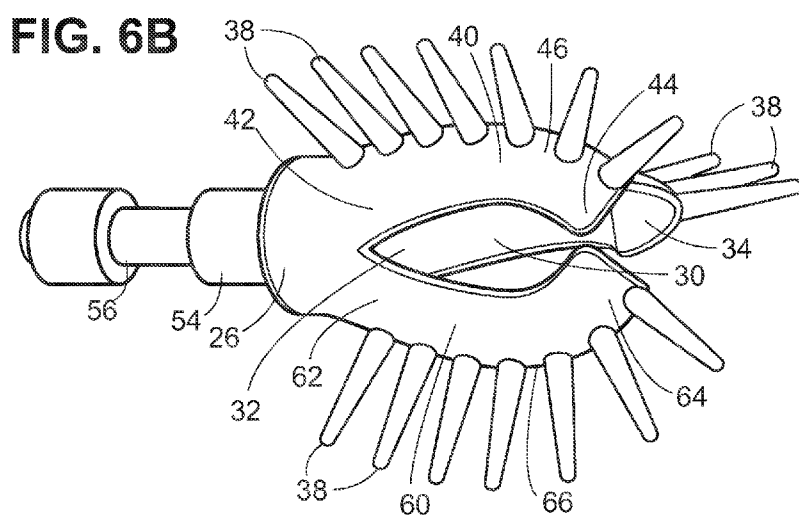
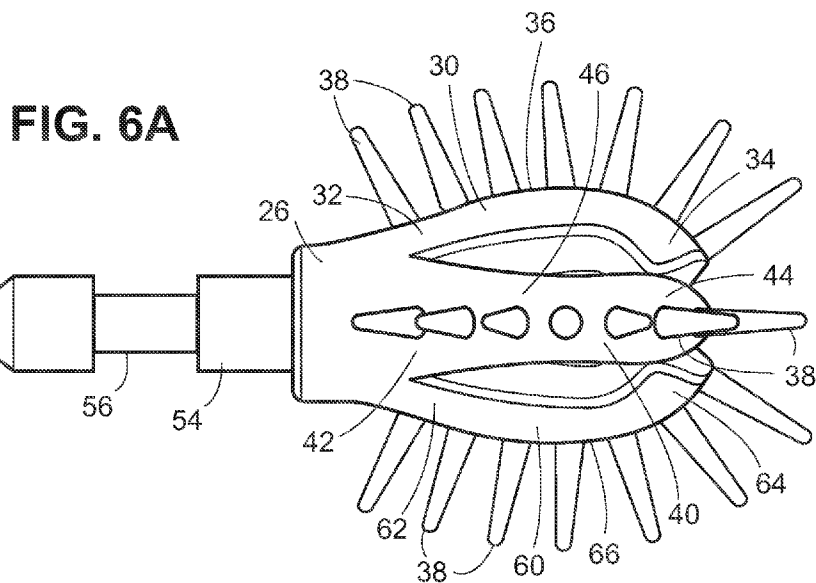

FIG. 7

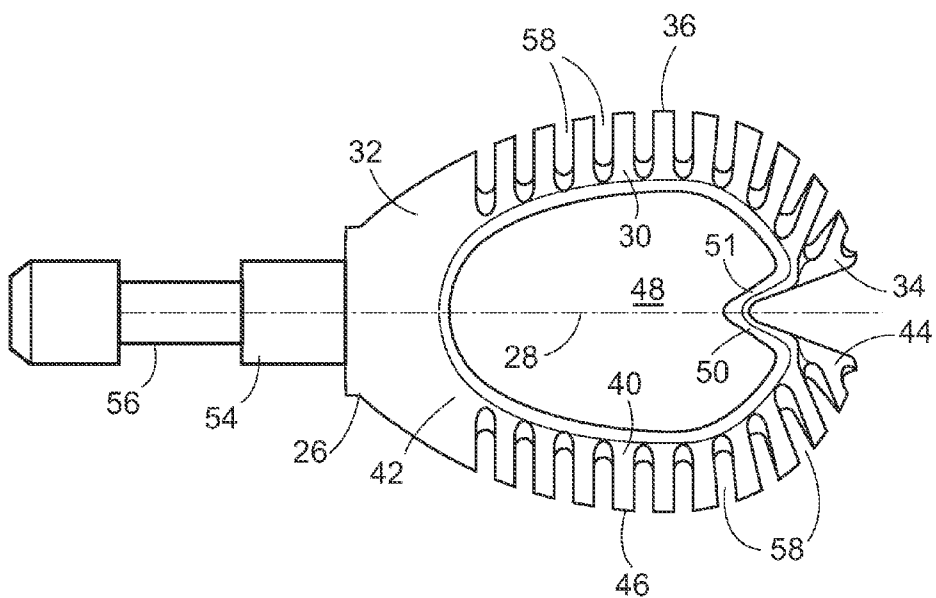
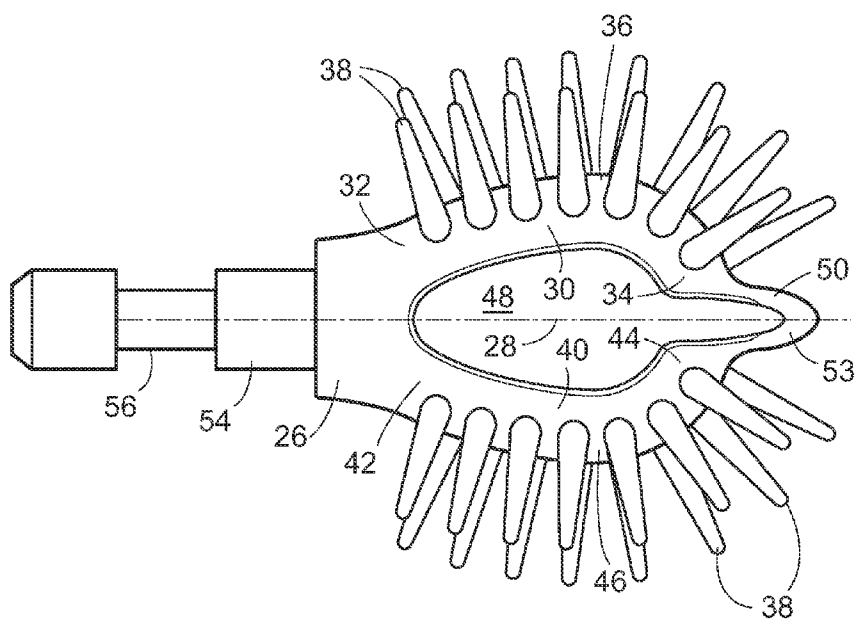

FIG. 8





**COMPRESSIBLE COSMETIC APPLICATOR**

**CROSS-REFERENCE TO RELATED APPLICATIONS**

**[0001]** The present application is a divisional application which claims priority from U.S. Non-provisional application Ser. No. 12/765,007, which in turn claims priority from U.S. Provisional Application No. 61/179,277, filed May 18, 2009.

**FIELD OF THE INVENTION**

**[0002]** The present invention is in the field of cosmetic packaging that includes an applicator wand. More particularly, the invention is an applicator head portion for attaching to an applicator wand for use with cosmetics such as mascara.

**BACKGROUND OF THE INVENTION**

**[0003]** For the convenience of the cosmetic user, cosmetic packaging often includes a cosmetic applicator suitable for dispensing the particular cosmetic contained in the package reservoir or vial. Mascara packaging, for example, usually includes an applicator wand that extends into a tubular vial. Cosmetic applicator wands generally comprise a handle portion, a rod extending from the handle portion to an application end and an applicator head separately attached to or integrally molded with the application end of the rod. The handle portion doubles as a closure cap for the cosmetic product reservoir or vial. The rod extends the reach of the wand into the product reservoir for retrieving product from the vial. The applicator head is loaded with product from the reservoir, transports the product to the application area (e.g., eyelashes) and delivers the product to the application area. The applicator head may additionally be used to ‘dress’ the applied product, e.g., spread, thin or thicken the application, separate lashes, etc. Applicator head configurations are determined by a number of factors including the ergonomics of the treatment area on the user, desired application characteristics and dimensions of the packaging from which a cosmetic product is drawn. For example, conventional or ‘stock’ mascara applicator heads comprising a twisted wire core brush with bristles extending from the core have a generally elongated cylindrical bristle envelope (as defined by the bristle tips), though the cylindrical envelope is often tapered for example at one or both ends. Corresponding conventional or ‘stock’ containers have a generally elongate vial for storing mascara product with a wiper in the neck of the vial through which the applicator head is drawn to control the dose of product loaded on the brush. Conventional brushes, vials and wipers are available in a relatively small number of stock sizes. Molded applicator heads having a variety of shapes and configurations are also known, a number of which have a core with bristle-like tines extending to form an elongated cylindrical envelope in dimensions and overall configuration that is similar to the more conventional twisted wire core brushes. Due to the similarity in dimensions and overall configuration, these molded applicators can be readily used in conventional packaging having stock vial and wiper dimensions. This significantly reduces production costs by avoiding the necessity for custom tooling and dies for vials and wipers with non-conventional dimensions.

**[0004]** However, there is a recent trend in the use of molded applicator heads that have non-conventional dimensions and/or shapes (e.g., spherical—see for example U.S. Publ. No. 2008/0202546 A1). Applicator heads with non-conventional

dimensions and shapes are said to advantageously, for example, enhance ‘volumizing’ while avoiding ‘clumping’. However, the non-conventional dimensions and shapes prevent these applicator heads from being used practically speaking with conventional or stock vials and wipers. For example, the non-conventional dimensions or shapes are either too large to fit through a stock wiper, or are too oddly shaped to be wiped effectively by a stock wiper resulting in messy and/or unpredictable wiping characteristics. Additionally, applicator heads with non-conventional dimensions or shapes may require that other parts of the package be customized to accommodate the larger dimensions or shapes, e.g., rods, wipers and vials may need to be enlarged. These custom package pieces may become unwieldy and unattractive. Also, applicator heads with non-conventional dimensions or shapes may require additional custom tooling and dies to produce not only the applicator head, but corresponding wipers, vials, rods and caps dimensioned to accommodate the non-conventional applicator heads.

**[0005]** U.S. Pat. Nos. 4,446,880 and 4,545,393 to Gueret and 7,467,905 to Habatjou disclose make-up brushes/applifiers that are variable in diameter by varying the length in response to manipulation of actuation means or an adjuster element. In order to achieve an expanded configuration, the actuation means/adjuster element must be manipulated—and inconvenience for the user. Furthermore, there is no indication that the brush or applicator in an expanded configuration is capable of being drawn through a relatively smaller wiper opening. The ‘880 and ‘393 disclosures clearly indicate that the bellows embodiment has sufficient elasticity to cause it to resume the elongated reduced diameter portion, i.e., the brush is biased to the smaller configuration rather than the expanded configuration of the present invention. The ‘905 disclosure appears to be similar. The disclosed brushes are also relatively complex in both construction (numerous parts to be assembled) and use (manipulation of the actuation means or adjuster element to achieve an expanded configuration).

**[0006]** U.S. Pat. No. 4,869,612 to Mooney discloses a similarly complex liquid applicator in which pads on supports are urged away from a central shaft by shortening the shaft to arching the supports into an expanded configuration in spring compression. This is contrary to the present invention where the static state of the curved supports is the expanded position, i.e., there is no spring compression in the expanded configuration.

**[0007]** None of the foregoing prior art references disclose an applicator that is biased to a substantially enlarged configuration, but readily collapses to facilitate withdrawal through a relatively small wiper opening.

**[0008]** Accordingly there is a need for a simplified and cost effective applicator head for cosmetic products such as mascara wherein the applicator head automatically expands to larger than conventional dimensions or shapes, but can be used in a conventionally dimensioned and shaped packaging, i.e., a stock vial and wiper.

**SUMMARY OF THE INVENTION**

**[0009]** The present invention is an applicator head for cosmetic products such as mascara wherein the applicator head exhibits non-conventional dimensions or shapes, but can be used in a conventionally dimensioned and shaped packaging, i.e., a stock vial and wiper. The present invention solves the need exhibited by the prior art by providing a relatively large cosmetic applicator head for application purposes, but the

applicator head collapses sufficiently to be used in a stock vial and drawn through a stock wiper system. The applicator head comprises a base adapted to be connected to an applicator rod which is in turn connected to handle portion in the form of a cap/closure for a product vial. A central longitudinal axis is defined through the base. At least two arched supports extend from the base along the longitudinal axis. Each support extends from a proximal end that is connected to the base to a distal end. Each of the two arched supports has an outwardly directed surface adapted to convey and apply cosmetic product, e.g., mascara. The two supports are outwardly biased to define and maintain a clearance about the longitudinal axis. The two supports are adapted to flex into the clearance when the applicator head is drawn through the first dimension of the wiper opening. The resulting applicator head has a relatively large, circle-like or heart-shaped application configuration that exhibits the benefits of a non-conventional applicator head, but that collapses to a configuration and dimension suitable for use in a conventional, stock vial and wiper system.

[0010] The outwardly directed surface of each support is adapted to convey and apply cosmetic by being provided with projections, tines, bristles, ribs, grooves or other surface features that are suitable for loading, transporting and applying cosmetic product such as mascara.

[0011] Another embodiment of the applicator head has plurality of arched supports extending from the base along the longitudinal axis. Each support extends from a proximal end connected to the applicator head base to a distal end. Each of the plurality of arched supports has an outwardly directed surface adapted to convey and apply cosmetic product. Each of the plurality of supports is outwardly biased to define and maintain a clearance about the longitudinal axis. Each of the plurality of supports is adapted to flex into the clearance when the applicator head is drawn through the stock wiper opening.

#### DESCRIPTION OF THE DRAWINGS

[0012] FIG. 1 shows an applicator wand including the applicator head of the present invention in elevation view inserted in a vial and wiper shown in cross-section, with the applicator head partially compressed as it begins to pass through the wiper.

[0013] FIG. 2 shows the applicator wand of FIG. 1 including the applicator head of the present invention in elevation view inserted in a vial and wiper shown in cross-section, with the applicator head fully expanded within the vial.

[0014] FIG. 3 is an elevation view of the applicator head illustrated in FIGS. 1 and 2, removed from the application wand.

[0015] FIG. 4 is an elevation view of another embodiment of the applicator head of the invention including a hinge connecting the distal ends of the arched supports.

[0016] FIG. 5 is an elevation view of yet another embodiment of the applicator head of the invention wherein the distal ends of the arched supports are directly connected with no intervening structure.

[0017] FIG. 6A is an elevation view and FIG. 6B is a perspective view of yet another embodiment of the compressible mascara applicator head of the present invention wherein a plurality of arched supports are provided, e.g., three or more supports.

[0018] FIG. 7 is an elevation view of yet another embodiment of the applicator head of the invention wherein the

outwardly directed applicator surfaces 36, 46 are adapted with clearances in the form of grooves or cuts.

[0019] FIG. 8 is an elevation view of yet another embodiment of the applicator of the invention wherein the hinge is in the form of an outwardly directed web.

#### DETAILED DESCRIPTION OF THE INVENTION

[0020] A compressible mascara applicator head according to the invention is shown in FIGS. 1, 2 and 3 at reference number 2. The applicator head has relatively larger than conventional dimensions preferred for loading and application purposes, but collapses or compresses substantially when drawn through a conventional wiper.

[0021] The applicator head 2 is shown in a preferred embodiment in its environment, a cosmetic package system 4 including a vial 6, an applicator wand 8 and a wiper 10. The wand 8 includes a handle portion 12, a rod 14 attached to and extending from the handle portion to an application end 16 and the applicator head 2 extending from the application end 16 of the rod 14. The handle portion 12 doubles as a closure cap 18 for the vial 6. The cap is provided with internal threads (not shown) suitable for cooperative engagement with external threads 20 on a neck 22 of the vial 6 to effect a secure closure. Note that in FIGS. 1 and 2, the applicator wand 8 including the handle portion 12, rod 14 and applicator head 2 are illustrated in elevation view, while the vial 6 including the wiper 10 are illustrated in cross-sectional view.

[0022] The wiper 10 defines a wiper opening 24 with a first dimension (FIG. 2). The dimension of the wiper opening 24 may be substantially the same as the diameter of the rod 14, so that the rod 14 closely occupies the wiper opening 24 as illustrated. However, the rod may also be a suitable smaller diameter. The diameter of the rod corresponding diameter of the wiper opening 24 can be in the conventional range of about 0.1 inches to 0.4 inches.

[0023] Referring now to FIG. 3, the applicator head 2 comprises a base 26 adapted to be connected to and extend from the application end 16 of the rod 14 (shown in FIGS. 1 and 2). The applicator head 2 may be separately attached to or integrally molded with the application end 16 of the rod 14. When it is separately attached, the base 26 is connected to the application end 16 of the rod 14 by conventional means. For example, the base 26 may include a mounting post or lug 54 (FIG. 3) extending from the base 26. The post 54 is dimensioned to be received in a bore (not shown) in the application end 16 of the rod 14. The mounting post 54 may include a reduced diameter portion 56 to facilitate 'staking' of the rod 14 to the post 54. Alternatively, the post 54 may be secured to the rod 14 by any conventional means for securing a molded applicator head to an applicator wand such as, for example, heat staking, press fit, snap fit, pinning, adhering, bonding or welding. The post 54 may have grooves, flutes, annular rings or cuts, or any other structural details to improve the fastening ability to the rod 14. A central longitudinal axis 28 is defined through the base 26. An arched first support 30 extends along and spaced from the longitudinal axis 28 from a first proximal end 32 connected to the base 26 to a first distal end 34. The first support 30 has a first outwardly directed applicator surface 36 adapted to convey and apply cosmetic product such as, for example, mascara. An arched second support 40 extends along and spaced apart from the longitudinal axis 28 generally opposite the first support 30. The second support 40 extends from a second proximal end 42 connected to the base 26 to a second distal end 44. The second support 40 has a

second outwardly directed applicator surface **46** adapted to convey and apply mascara product.

**[0024]** As illustrated, tines **38** may be provided that project out from the outwardly directed applicator surfaces **36**, **46** to facilitate the loading, conveyance, application and doctoring of cosmetic product. Alternatively, the outwardly directed surfaces **36**, **46** of each of the first and second support, **30** and **40** respectively, may be adapted to convey and apply cosmetic by being provided with other types of projections, bristles, tines, flocking, particles, ribs, grooves, discs, slits, cuts, holes, dimples, foam or other surface features or surface treatments (e.g., abrading) that are suitable for loading, transporting and applying cosmetic product such as, for example, mascara. For example, as shown in FIG. 7, the outwardly directed applicator surfaces **36**, **46**, may be provided with recesses in the form of grooves or cuts **58** suitable for loading, transporting and applying cosmetic product such as mascara. Additionally, the adaptations provided to each of the outwardly directed surfaces **36**, **46** may differ to facilitate different functions. For example, surface **36** may be provided with broader tines better suited for loading and application of mascara to lashes, while surface **46** may be provided with thinner tines better suited for doctoring of applied mascara, or shaping and separation of lashes.

**[0025]** At least one of the first support **30** and the second support **40** is outwardly biased from the longitudinal axis **28** to define an expanded configuration for the applicator head as illustrated in FIGS. 2 and 3. Preferably, both the first support **30** and the second support **40** are outwardly biased to provide the expanded configuration. The expanded configuration created by the outwardly biased first and/or second supports **30**, **40** defines a relatively larger clearance **48** about the longitudinal axis **28** between the first support **30** and the second support **40** (see FIGS. 2 and 3). For an applicator head intended for application of mascara, for example, the dimension of the expanded configuration taken as the greatest distance between outwardly directed application surfaces **36** and **46** would ideally be in the range of about 0.125 inches to about 0.8 inches. In the expanded configuration with relatively larger clearance **48**, the applicator head **2** is substantially larger than the first dimension of the wiper opening **24** (see FIG. 2). To permit the relatively larger applicator head **2** to pass through the relatively smaller wiper opening **24** in either direction at least one of the first support **30** and the second support **40** is adapted to flex into the clearance **48** to define a compressed configuration (see FIG. 1). In the compressed configuration, the clearance **48** is substantially reduced in size. The compressed configuration defined by the ability of the flexing of the support or supports permits the applicator head to be pushed into or drawn out through the relatively smaller dimension of the wiper opening **24**. Preferably, both the first support **30** and the second support **40** flex into the clearance **48** when the applicator head is drawn through the wiper opening **24** as shown in FIG. 1. To facilitate flexing of the first and/or second support **30**, **40**, the entire length of each support may be flexible, or a portion of each support may be thinned or coined or otherwise worked to soften the material, e.g., the proximal end **32**, **42**, of one or each support may be weakened to promote flexing into the clearance **48**. After the applicator head **2** has passed through the wiper opening **24** in either direction, i.e., either inside the vial or outside the vial, the applicator head **2** returns fully to the expanded configuration shown in FIGS. 2 and 3. The arched configuration of the first support **30** and second sup-

port **40** facilitate entry of the applicator head **2** into the relatively narrow wiper dimensions from inside the vial **6** as the wand is withdrawn from the vial **6**, as well as from outside the vial **6** as the applicator head **2** is returned into the vial **6**.

**[0026]** Although illustrated in FIGS. 1, 2 and 3 with a first support **36** and second support **46**, the compressible mascara applicator of the present invention may further comprise a plurality of arched supports, e.g., three or more supports, as illustrated, for example, in FIGS. 6A and 6B. Referring to FIGS. 6A and 6B, an arched first support **30** extends along and spaced from the longitudinal axis **28** from a first proximal end **32** connected to the base **26** to a first distal end **34**. The first support **30** has a first outwardly directed applicator surface **36** adapted to convey and apply cosmetic product such as, for example, mascara. An arched second support **40** extends along and spaced apart from the longitudinal axis **28** approximately opposite the first support **30**. The second support **40** extends from a second proximal end **42** connected to the base **26** to a second distal end **44**. The second support **40** has a second outwardly directed applicator surface **46** adapted to convey and apply mascara product. An arched third support **60** extends along and spaced apart from the longitudinal axis **28** approximately opposite and equally spaced from the first support **30** and second support **40**. The third support **60** extends from a third proximal end **62** connected to the base **26** to a third distal end **64**. The third support **60** has an outwardly directed applicator surface **66** adapted to convey and apply mascara product. The arched supports **30**, **40** and **60** may be provided with tines **38**. While shown with three arched supports, the applicator head may have any suitable number of arched supports, each with an outwardly directed application surface adapted to convey and apply cosmetic product such as, for example, mascara, with, for example, tines or other surface structure. One or more of the plurality of arched supports **30**, **40**, **60** are outwardly biased from the longitudinal axis **28** to define an expanded configuration including a clearance **48** for the applicator head (see FIGS. 6A and 6B). One or more of the plurality of arched supports **30**, **40**, **60** are also adapted to flex into the clearance **48** to define a compressed configuration as described above with respect to the two arched support embodiment, i.e., sufficiently small enough to permit the applicator head to pass through the wiper opening. Once through the opening in either direction, i.e., inside the vial or outside the vial, the applicator head returns fully to the expanded configuration shown in FIGS. 6A and 6B.

**[0027]** The first support **30** and second support **40** may be connected by a hinge **50** in the form of an inwardly directed flexible web **51** connecting the first distal end **34** and the second distal end **44** (FIGS. 4, 7). Alternatively, the hinge **50** may take the form of an outwardly directed flexible web **53** (FIG. 8) that is shaped to guide the applicator head **2** into the wiper opening **24** when the wand **8** is returned to the vial **6**. The hinge **50** stabilizes the position of the first distal end **34** of the first support **30** relative to the second distal end **44** of the second support **40** as the applicator head **2** is pulled or pushed through the wiper opening. Additionally, as the hinge **50** pinches closed when the applicator head **2** is drawn through the wiper opening **24**, excess mascara that might otherwise remain on the first and second distal end **34**, **44**, respectively, of each support is squeezed out of the hinge **50** and removed by the wiper **10**. Thus, the hinge **50** avoids the excess cosmetic build-up that is typically found on the free end of conventional applicators.

[0028] Optionally, the first distal end **34** of the first support **30** may be connected more directly to the second distal end **44** of the second support **40** as shown in FIG. **5** at reference number **52**, i.e., without an intervening structure. The direct connection would be adapted by selection of material and/or structure to provide sufficient flexibility of one or both supports **30**, **40** to permit them to flex into the clearance **48** to facilitate passage through the wiper opening. This arrangement is believed to have the advantage of providing a greater propensity for the applicator head to return to the first expanded configuration from the compressed configuration after passing through the wiper opening for optimal performance.

[0029] The compressible mascara applicator head **2** can be made from any suitable material by molding, machining or other known processes. Suitable materials include, but are not limited to, polymer or rubber, including thermoplastic polymers and elastomers, fabric, non-wovens and meshes. Suitable materials would have sufficient outward bias to return to the expanded configuration and sufficient inward flexibility to be drawn through a relatively smaller wiper opening for multiple cycles typical during the useful life of a cosmetic package. A preferred material is Hytrel, a thermoplastic polyester elastomer made by DuPont. Preferably, the applicator head is made from a thermoplastic polyester elastomer. The entire applicator head **2** may be made from a single material, or various parts of the head may be made from different materials, i.e., at least one of the base **26**, the first support **30** and the second support **40** may be made from a thermoplastic polyester elastomer, while other parts are made from another type of plastic. The applicator head **2** can be molded as a unitary piece, or in parts. The various parts can be molded together, as for example, by bi-injection, sequential injection, multiple-injection or over-molding one or more materials over a base material. Alternatively, the applicator head **2** may be assembled from parts by bonding, welding etc. Preferably, the entire applicator head **2**, or at least one of the base **26**, the first support **30** and the second support **40** are made of a material having a durometer in the range of 40-100 Shore D, and more particularly a material having a durometer in the range of 62-70 Shore D.

[0030] While the hollow heart-shaped configuration illustrated is a preferred embodiment, other configurations are contemplated, such as, for example, a “U” or “V” shape, hollow polygon, hollow clover shape, ellipse (similar to FIG. **5**), etc.

[0031] In addition to the foregoing, due to its bias to the larger, expanded configuration, the applicator head has the added advantage of being capable of retrieving product from the walls of the vial (see FIG. **2**) that might otherwise be unavailable to an applicator head with conventional dimensions, e.g., a conventional twisted wire brush.

[0032] While the invention has been primarily described in the context of an applicator for a mascara product, the applicator head of the present invention could be used for the application of any cosmetic product that would benefit from the use of a broad, enlarged applicator head configuration and that can be drawn through a conventional wiper, e.g., a lip gloss, an eye shadow, a foundation or a facial or skin treatment product.

What is claimed is:

1. A compressible mascara applicator head for use in a package including a wiper defining a wiper opening with a first dimension, the applicator head comprising:

a base adapted to be connected to an applicator rod, a central longitudinal axis defined through the base;

an arched first support extending along the longitudinal axis from a first proximal end connected to the base to a first distal end, the first support having a first outwardly directed applicator surface adapted to convey and apply mascara product;

an arched second support extending along the longitudinal axis approximately opposite the first support, the second support extending from a second proximal end connected to the base to a second distal end, the second support having a second outwardly directed applicator surface adapted to convey and apply mascara product; and

an arched third support extending from the base along the longitudinal axis, the third support spaced approximately opposite from the first support and the second support, the third support extending from a third proximal end connected to the base to a third distal end, the third support having an outwardly directed applicator surface adapted to convey and apply a cosmetic product;

wherein at least one of the first support, the second support and the third support is outwardly biased from the longitudinal axis to define an expanded configuration with a second dimension greater than the first dimension of the wiper opening, the expanded configuration including a clearance about the longitudinal axis between the first support, the second support and the third support, and the at least one of the first support, the second support and the third support is adapted to flex into the clearance when the applicator head is drawn through the first dimension of the wiper opening; and

wherein at least one of the first distal end, the second distal end and the third distal end is a free end, or is connected to another of the first distal end, the second distal end and the third distal end by a hinge.

2. The compressible mascara applicator head of claim **1** wherein each of the first support, the second support and the third support is outwardly biased from the longitudinal axis to define the expanded configuration including the clearance, and each of the first support, the second support and the third support is adapted to flex into the clearance when the applicator head is drawn through the first dimension of the wiper opening.

3. The compressible mascara applicator head of claim **1** further comprising:

a first plurality of tines extending outwardly from at least one of the applicator surface of the first support, the applicator surface of the second support and the applicator surface of the third support.

4. The compressible mascara applicator head of claim **1** further comprising:

a first plurality of tines extending outwardly from the applicator surface of the first support, a second plurality of tines extending outwardly from the applicator surface of the second support and a third plurality of tines extending outwardly from the applicator surface of the third support.

5. The compressible mascara applicator head of claim **4** wherein at least one of the first plurality of tines, the second plurality of tines and the third plurality of tines is adapted to convey and apply a cosmetic product.

6. The compressible mascara applicator head of claim 4 wherein at least one of the first plurality of tines, the second plurality of tines and the third plurality of tines is adapted to separate lashes.

7. The compressible mascara applicator head of claim 3 wherein the first plurality of tines is adapted to perform at least one function selected from conveying mascara, applying mascara, doctoring mascara, shaping lashes and separating lashes.

8. The compressible mascara applicator head of claim 4 wherein the first plurality of tines is adapted to perform at least one function selected from conveying cosmetic, applying cosmetic and doctoring cosmetic.

9. The compressible mascara applicator head of claim 8 wherein the second plurality of tines is adapted to perform at least one function selected from conveying mascara, applying mascara, doctoring mascara, shaping lashes and separating lashes.

10. The compressible mascara applicator of claim 8 wherein the third plurality of tines is adapted to perform at least one function selected from conveying mascara, applying mascara, doctoring mascara, shaping lashes and separating lashes.

10. The compressible mascara applicator of claim 1 wherein at least one of the base, the first support, the second support and the third support are made from a thermoplastic polyester elastomer.

11. The compressible mascara applicator of claim 1 wherein at least one of the base, the first support, the second support and the third support are made of a flexible material having a durometer in the range of 40-100 Shore D.

12. The compressible mascara applicator of claim 11 wherein the at least one of the base, the first support, the second support and the third support is made of a flexible material having a durometer in the range of 62-70 Shore D.

13. A compressible mascara applicator head for use in a package including a wiper defining a wiper opening with a first dimension, the applicator head comprising:

a base adapted to be connected to an applicator rod, a central longitudinal axis defined through the base;

a plurality of arched supports extending from the base along the longitudinal axis, each support extending from a proximal end connected to the base to a distal end, each of the plurality of arched supports having an outwardly directed surface adapted to convey and apply mascara product, the plurality of supports being outwardly biased to define and maintain a clearance about the longitudinal axis and each of the plurality of supports is adapted to flex into the clearance when the applicator head is drawn through the first dimension of the wiper opening, wherein the distal end of at least one of the plurality of arched supports is a free end, or is connected to the distal end of another of the plurality of arched supports by a hinge.

14. The compressible mascara applicator head of claim 13 further comprising a plurality of tines extending from the outwardly directed surface of one or more of the plurality of arched supports.

15. The compressible mascara applicator head of claim 13 further comprising a plurality of tines extending from the outwardly directed surface of each of the plurality of arched supports.

16. The compressible mascara applicator of claim 13 wherein at least one of the base and the plurality of arched supports are made from a thermoplastic polyester elastomer.

17. The compressible mascara applicator of claim 1 wherein at least one of the base and the plurality of arched supports are made of a flexible material having a durometer in the range of 40-100 Shore D.

18. The compressible mascara applicator of claim 17 wherein the at least one of the base and the plurality of arched supports is made of a flexible material having a durometer in the range of 62-70 Shore D.

\* \* \* \* \*