



(12) **DEMANDE DE BREVET CANADIEN  
CANADIAN PATENT APPLICATION**

(13) **A1**

(86) Date de dépôt PCT/PCT Filing Date: 2017/12/15  
 (87) Date publication PCT/PCT Publication Date: 2018/06/21  
 (85) Entrée phase nationale/National Entry: 2019/06/13  
 (86) N° demande PCT/PCT Application No.: CA 2017/051522  
 (87) N° publication PCT/PCT Publication No.: 2018/107298  
 (30) Priorité/Priority: 2016/12/16 (US62/435,189)

(51) Cl.Int./Int.Cl. *G01B 21/16* (2006.01),  
*F03D 17/00* (2016.01), *G01B 11/14* (2006.01),  
*G01B 11/16* (2006.01), *G01B 21/32* (2006.01),  
*G01S 17/10* (2006.01)  
 (71) Demandeurs/Applicants:  
 INNERGEX ENERGIE RENOUVELABLE INC., CA;  
 INSTITUT NATIONAL D'OPTIQUE, CA  
 (72) Inventeurs/Inventors:  
 DAVID, VINCENT, CA;  
 CANTIN, DANIEL, CA;  
 GUILLEMETTE, ROBERT, CA;  
 CLOUTIER, JONATHAN, CA...  
 (74) Agent: BENOIT & COTE INC.

(54) Titre : SYSTEME ET PROCEDE DE SURVEILLANCE DE LA DEVIATION DES PALES D'EOLIENNES  
 (54) Title: SYSTEM AND METHOD FOR MONITORING BLADE DEFLECTION OF WIND TURBINES

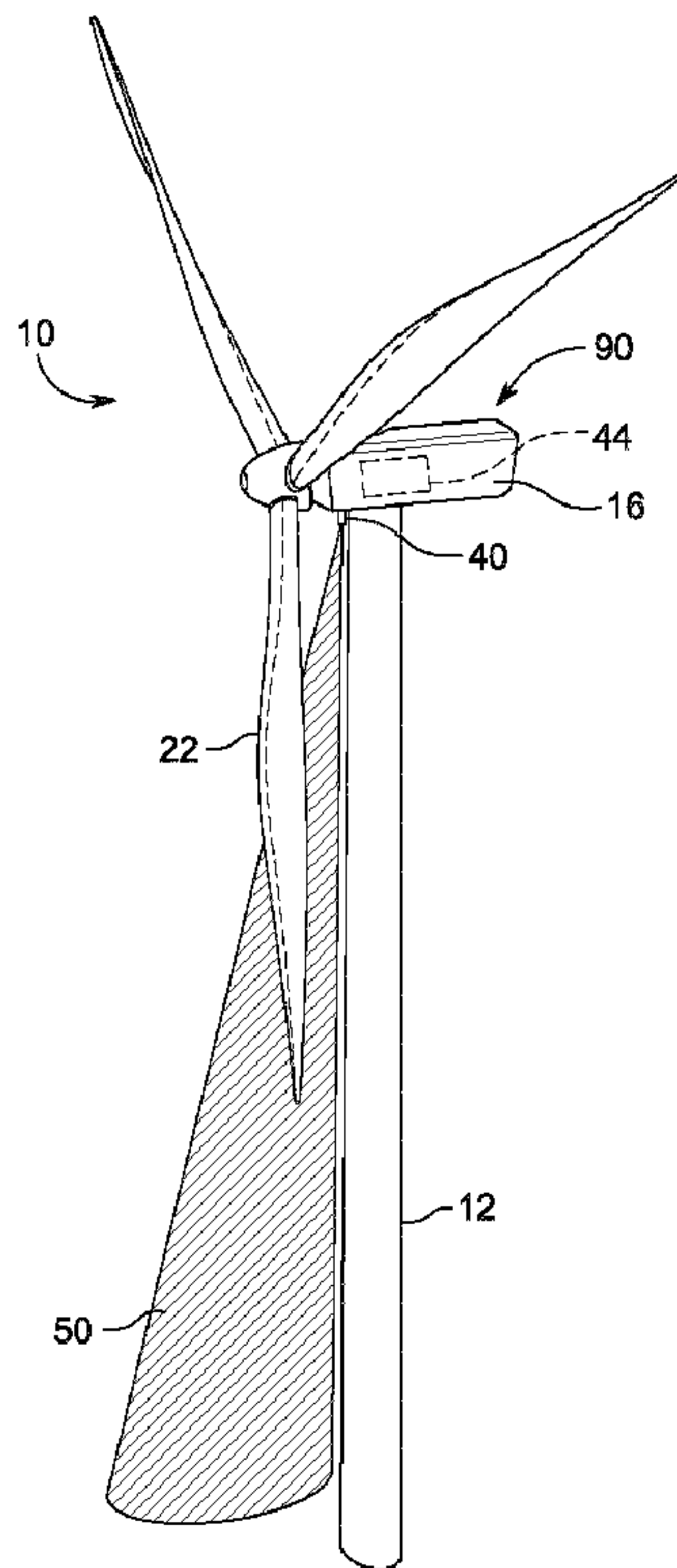

FIG. 2

(57) Abrégé/Abstract:

Described is a system for monitoring deflection of turbine blades of a wind turbine comprising a tower. The system comprises a position detecting apparatus mounted to the wind turbine, the position detection apparatus comprising position detection

(57) **Abrégé(suite)/Abstract(continued):**

components each detecting a presence or absence of a corresponding one of the segments of the turbine blades; and a deflection controller configured to receive the presence or absence detection and to use the presence or absence detection to determine a distance of each of the segments of the turbine blades relative to the tower, whereby the distance of each of the segments of the turbine blades relative to the tower is representative of the deflection of the turbine blades.

(12) INTERNATIONAL APPLICATION PUBLISHED UNDER THE PATENT COOPERATION TREATY (PCT)

(19) World Intellectual Property  
Organization  
International Bureau(43) International Publication Date  
21 June 2018 (21.06.2018)(10) International Publication Number  
**WO 2018/107298 A1**

## (51) International Patent Classification:

*G01B 21/16* (2006.01)      *G01B 11/16* (2006.01)  
*F03D 17/00* (2016.01)      *G01B 21/32* (2006.01)  
*G01B 11/14* (2006.01)      *G01S 17/10* (2006.01)

## (21) International Application Number:

PCT/CA2017/051522

## (22) International Filing Date:

15 December 2017 (15.12.2017)

## (25) Filing Language:

English

## (26) Publication Language:

English

## (30) Priority Data:

62/435,189      16 December 2016 (16.12.2016)      US

(71) Applicants: **CARTIER ENERGIE EOLIENNE INC.**

[CA/CA]; 1111, rue St-Charles Ouest, Tour Est, bureau  
 1155, Longueuil, Québec J4K 5G4 (CA). **INSTITUT  
 NATIONAL D'OPTIQUE** [CA/CA]; 2740 Rue Einstein,  
 Quebec, Québec G1P 4S4 (CA).

(72) Inventors: **DAVID, Vincent**; 59 Rue Saint-Elzear, Riv-

iere-Du-Loup, Québec G5R 1X6 (CA). **CANTIN, Daniel**;  
 1452 Rue Milton, Ville De Quebec, Québec G2G 1X5 (CA).

**GUILLEMETTE, Robert**; 8 rue de la Roseraie, Shef-  
 ford, Québec J2M 1L7 (CA). **CLOUTIER, Jonathan**; 715

Boulevard de Saint-Majorique, Gaspé, Québec G4X 6T3  
(CA).(74) Agent: **BENOÎT & CÔTÉ INC.**; 560 Cremazie Boulevard  
East, Suite 300, Montréal, Québec H2P 1E8 (CA).(81) Designated States (*unless otherwise indicated, for every  
kind of national protection available*): AE, AG, AL, AM,  
AO, AT, AU, AZ, BA, BB, BG, BH, BN, BR, BW, BY, BZ,  
CA, CH, CL, CN, CO, CR, CU, CZ, DE, DJ, DK, DM, DO,  
DZ, EC, EE, EG, ES, FI, GB, GD, GE, GH, GM, GT, HN,  
HR, HU, ID, IL, IN, IR, IS, JO, JP, KE, KG, KH, KN, KP,  
KR, KW, KZ, LA, LC, LK, LR, LS, LU, LY, MA, MD, ME,  
MG, MK, MN, MW, MX, MY, MZ, NA, NG, NI, NO, NZ,  
OM, PA, PE, PG, PH, PL, PT, QA, RO, RS, RU, RW, SA,  
SC, SD, SE, SG, SK, SL, SM, ST, SV, SY, TH, TJ, TM, TN,  
TR, TT, TZ, UA, UG, US, UZ, VC, VN, ZA, ZM, ZW.(84) Designated States (*unless otherwise indicated, for every  
kind of regional protection available*): ARIPO (BW, GH,  
GM, KE, LR, LS, MW, MZ, NA, RW, SD, SL, ST, SZ, TZ,  
UG, ZM, ZW), Eurasian (AM, AZ, BY, KG, KZ, RU, TJ,  
TM), European (AL, AT, BE, BG, CH, CY, CZ, DE, DK,  
EE, ES, FI, FR, GB, GR, HR, HU, IE, IS, IT, LT, LU, LV,  
MC, MK, MT, NL, NO, PL, PT, RO, RS, SE, SI, SK, SM,  
TR), OAPI (BF, BJ, CF, CG, CI, CM, GA, GN, GQ, GW,  
KM, ML, MR, NE, SN, TD, TG).

(54) Title: SYSTEM AND METHOD FOR MONITORING BLADE DEFLECTION OF WIND TURBINES

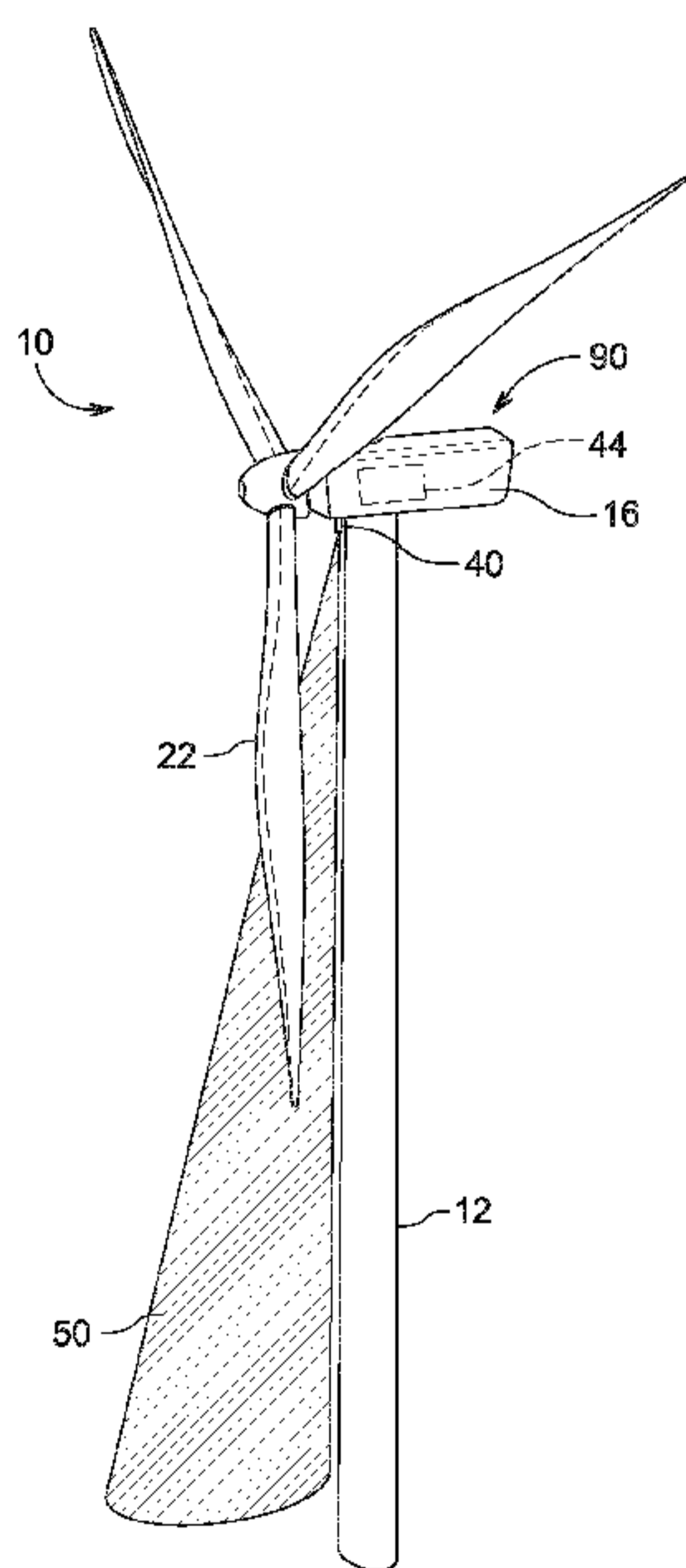

FIG. 2

(57) Abstract: Described is a system for monitoring deflection of turbine blades of a wind turbine comprising a tower. The system comprises a position detecting apparatus mounted to the wind turbine, the position detection apparatus comprising position detection components each detecting a presence or absence of a corresponding one of the segments of the turbine blades; and a deflection controller configured to receive the presence or absence detection and to use the presence or absence detection to determine a distance of each of the segments of the turbine blades relative to the tower, whereby the distance of each of the segments of the turbine blades relative to the tower is representative of the deflection of the turbine blades.

WO 2018/107298 A1

# WO 2018/107298 A1

---

**Published:**

- *with international search report (Art. 21(3))*
- *in black and white; the international application as filed contained color or greyscale and is available for download from PATENTSCOPE*



## SYSTEM AND METHOD FOR MONITORING BLADE DEFLECTION OF WIND TURBINES

### CROSS-REFERENCE TO RELATED APPLICATION

**[0001]** This application claims priority from US patent provisional application 62/435,189 filed December 16, 2016, the specification of which is hereby incorporated herein by reference in its entirety.

### BACKGROUND

#### (a) Field

**[0002]** The invention relates to an arrangement to monitor the deflection or bending of an object, preferably to monitor the deflection or bending of a wind-turbine blade.

#### (b) Related Prior Art

**[0003]** Blades of modern wind turbines are quite long; they may measure up to 88 meters long or even more. Thus, their shape and their characteristics need to be monitored in order to optimize their aerodynamic profile by adjusting the blade pitch angle, especially to prevent sudden change in loads that could cause damage to one or multiple blades either by reaching critical deflection or by hitting the tower while the wind turbine is in operation.

**[0004]** More specifically, the deflection or bending of the blade near its tip-end needs to be known to prevent those damages.

**[0005]** It is known to attach strain gauges on the blade-surface. They are mainly used for test purposes to gather a certain knowledge about the blade when it is stressed.

**[0006]** The installation of gauges and the installation of their electrical cabling needed are expensive, especially beside a wind turbine which is in operation. The equipment (especially the cabling) is exposed to lightning strikes, thus the gauges are mainly used for time-limited test purposes.

**[0007]** It is also known, as described in US patent 9,000,970 B2, to use a system comprising a reflector arranged at a first position and an antenna-system arranged at a second position. The antenna system contains a transmit antenna and a receive antenna, while the reflector and the antenna-system are coupled by a radio signal. The radio signal is sent from the transmit antenna via the reflector towards the receive antenna. The receive antenna is connected with an evaluation unit, which is prepared to measure the deflection between the first end of the object and the second end of the object based on the received radio signal.

**[0008]** It is also known, as described in US patent publication 2011/0135466 A1, to use a system comprising a passive position detecting apparatus and a controller. The passive position detecting apparatus being configured to acquire and transmit data relating directly to a position of at least one of the turbine blades. The controller being configured to receive the data from the passive position detecting apparatus and compare such data to a known position reference to determine turbine blade deflection.

**[0009]** Other documents, such as European patent publication EP 2339173, US patents 7,246,991 and US 7,059,822, and US patent publication US2011/0134366 also aims to address that same problem, with limited successes.

**[0010]** Only a certain blade-deflection can be measured by these systems due to the location of the system-parts, the nature of the detection means, and other factors such as detection locations, etc. With most of them, only the deflection of the tip-end of the blade can be approximated. Most of them further require components on the blades. They are sensitive to weather. Thus, none of these solutions provides the desired level of precision nor provides the reliability to face all operating conditions of a wind turbine.

**[0011]** There is therefore a need for improvement in the field of wind turbine, and more precisely in the field of deflection monitoring of blades of wind turbines.

## **SUMMARY**

**[0012]** According to an embodiment, there is disclosed a system for monitoring deflection of turbine blades of a wind turbine comprising a tower, wherein the turbine blades comprise segments along a length of the turbine blades, the system comprising: a position detecting apparatus mounted to the wind turbine, the position detection apparatus comprising position detection components each detecting a presence or absence of a corresponding one of the segments of the turbine blades; and a deflection controller configured to receive the presence or absence detection and to use the presence or absence detection to determine a distance of each of the segments of the turbine blades relative to the tower, whereby the distance of each of the segments of the turbine blades relative to the tower is representative of the deflection of the turbine blades.

**[0013]** According to an aspect, the position detection components comprise a pulsed laser source and a sensor.

**[0014]** According to an aspect, each one of the position detection components is set at a distinct angle relative to a horizontal plane.

**[0015]** According to an aspect, each one of the position detection components is associated with a distinct channel resulting in a plurality of colinear channels.

**[0016]** According to an aspect, a power ratio of a power associated with a first one of the position detection components over a power associated with a second one of the position detection components is above about 5 to 1.

**[0017]** According to an aspect, each of the position detection components are set to a spread angle, and wherein the spread angle associated with a first one of the position detection components is different from the spread angle associated with a second one of the position detection components.

**[0018]** According to an aspect, a spread angle ratio of the spread angle associated with the first one of the position detection components over a spread



angle associated with the second one of the position detection components is above about 2 to 1.

**[0019]** According to an aspect, the wind turbine further comprises a nacelle and wherein the position detection apparatus is mounted under the nacelle.

**[0020]** According to an aspect, the system further comprises at least one of an inclinometer and an accelerometer; and wherein at least one of the inclinometer and accelerometer provides data regarding bending of the tower or inclination of the nacelle.

**[0021]** According to an aspect, the system further comprises a corrective system, wherein the deflection controller triggers actions to be performed by the corrective system upon detection of deflection of the turbine blades outside an acceptable range.

**[0022]** According to an aspect, the wind turbine comprise a nacelle mounted to the tower, a hub mounted to the nacelle, with the turbine blades mounted to the hub, wherein the corrective system is adapted to perform at least one of: altering pitch of at least one of the turbine blades; modifying blade load by modifying torque demand over the hub; modifying yawing of the nacelle; and applying a break on the hub.

**[0023]** According to an aspect, the position detecting apparatus further comprises a plurality of neighbor detection components each collecting data regarding a distinct lateral neighbor field of detection each corresponding to a distinct segment of rotation cycle of the turbine blades, whereby each of the neighbor detection components monitors a passage of blade tips of the turbine blades travelling through an associated distinct lateral neighbor field of detection at a distinct phase of a rotation cycle of the turbine blades.

**[0024]** According to an embodiment, there is disclosed system for monitoring deflection of turbine blades each having a blade tip of a wind turbine, the system comprising: a detecting apparatus mounted to the wind turbine distant



from the turbine blades, the detection apparatus comprising a plurality of neighbor detection components each collecting data regarding a distinct lateral neighbor field of detection each corresponding to a distinct segment of rotation cycle of the turbine blades, whereby each of the neighbor detection components monitors a passage of the blade tips of the turbine blades travelling through an associated distinct lateral neighbor field of detection at a distinct phase of a rotation cycle of the turbine blades when the turbine blades feature a level of deflection over a predetermined level; and a deflection controller configured to receive the collected data and to determine a deflection condition of the turbine blades accordingly.

**[0025]** According to an aspect, the neighbor detection components comprise a pulsed laser source and a sensor.

**[0026]** According to an aspect, the distinct lateral neighbor fields of detections correspond to field of views of the neighbor detection components set at distinct angles relative to a vertical plane.

**[0027]** According to an embodiment, there is disclosed method of monitoring clearance between turbine blades and a tower of a wind turbine, wherein the turbine blades comprise segments along a length of the turbine blades, the method comprising: detecting, using a position detecting apparatus mounted to the wind turbine distant from the turbine blades, presence or absence of a corresponding one of the segments of the turbine blades; and processing the detected presence or absence detection to determine a distance of each of the segments of the turbine blades relative to the tower, whereby the distance of each of the segments of the turbine blades relative to the tower is representative of the clearance of the turbine blades.

**[0028]** According to an aspect, the method further comprises at least one of: detecting an angular position of the turbine blades; associating detected presences or absences with a specific one of the turbine blades; and detecting anomalies associated with one of the turbine blades relative to the tower.

**[0029]** According to an aspect, the method further comprises detecting at least one of inclination data and proper acceleration data, wherein the step of processing further comprises processing the at least one of inclination data and proper acceleration data.

**[0030]** According to an aspect, the method further comprises receiving data extrinsic to the wind turbine, wherein the step of processing further comprises establishing parameters based at least on the extrinsic data.

**[0031]** According to an aspect, the step of processing further comprises comparing the clearance with parameters, and wherein the method further comprises: identifying a faulty condition based on comparison of the clearance with the parameters; and triggering corrective actions to prevent the turbine blades to hit the tower.

**[0032]** According to an aspect, implementations may comprise one or more of the following features.

### **BRIEF DESCRIPTION OF THE DRAWINGS**

**[0033]** Further features and advantages of the present disclosure will become apparent from the following detailed description, taken in combination with the appended drawings, in which:

**[0034]** Fig. 1 is a side view of a wind turbine in accordance with an embodiment;

**[0035]** Fig. 2 is a perspective view of a wind turbine showing detection area associated with the position detection apparatus in accordance with an embodiment;

**[0036]** Fig. 3 is a chart illustrating blade clearance data resulting from processing of data collected by the position detection apparatus according to three deflection levels;

**[0037]** Figs. 4A to 4C are schematic side views of a wind turbine and wind blade deflections according to three deflection levels;

**[0038]** Figs. 5A to 5C are schematic front views of the wind turbine and the detection area in accordance with an embodiment and interaction of a turbine blade with the detection area while crossing it;

**[0039]** Figs. 6A to 6C are schematic side views of the wind turbine in accordance with an embodiment in distinct conditions of inclination of the nacelle of the wind turbine; and

**[0040]** Fig. 7 is a flow chart provided steps performed according to an embodiment of the system.

**[0041]** It will be noted that throughout the appended drawings, like features are identified by like reference numerals.

## **DETAILED DESCRIPTION**

**[0042]** Reference now will be made in detail to embodiments of the present subject matter, one or more examples of which are illustrated in the drawings. Each example is provided by way of explanation, without limiting the scope of the present subject matter. In fact, it will be apparent to those skilled in the art that various modifications and variations can be made in the present subject matter without departing from its scope or spirit. For instance, features illustrated or described as part of one embodiment can be used with another embodiment to yield a still further embodiment. Thus, it is intended that the present subject matter covers such modifications and variations as come within the scope of the appended claims and their equivalents.

**[0043]** Fig. 1 illustrates a perspective view of a wind turbine **10**. As shown, the wind turbine **10** is a horizontal-axis wind turbine. The wind turbine **10** comprises a tower **12** (or a post) that extends from a base **14**, a nacelle **16** mounted on the tower **12**, and a rotor **18** that is coupled to the nacelle **16**. The rotor **18** comprises a rotatable hub **20** and usually at least three turbine blades **22** coupled to and



extending outward from the hub **20**. As shown, the rotor **18** comprises three turbine blades **22**. However, in an alternative embodiment, the rotor **18** may comprise more (or less) than three turbine blades **22**. Additionally, in the illustrated embodiment, the tower **12** is fabricated from tubular steel to define a longitudinal cavity (not illustrated) between the base **14** and the nacelle **16**. In an alternative embodiment, the tower **12** may be any suitable type of tower having any suitable height.

**[0044]** The turbine blades **22** may generally have any suitable length extending from their mounting part the hub **20** to the blade tip **35** that enables the wind turbine **10** to operate as described herein. For example, in one embodiment, the turbine blades **22** may have a length ranging from about 15 meters to about 88 meters. However, other non-limiting examples of blade lengths may comprise 10 meters or less, 20 meters, 37 meters or a length that is greater than 88 meters. For teaching purposes, the example of wind turbine **10** herein described will be of turbine blades **22** of 37 meters.

**[0045]** Additionally, the turbine blades **22** may be spaced about the hub **20** to facilitate rotating the rotor **18** to enable kinetic energy to be transferred from the wind into usable mechanical energy, and subsequently, electrical energy. Specifically, the hub **20** may be rotatably coupled to an electric generator (not shown) positioned within the nacelle **16** to permit electrical energy to be produced. Further, the turbine blades **22** may be mated to the hub **20** by coupling a blade root portion **24** to the hub **20** at a plurality of load transfer regions **26**. Thus, any loads induced to the turbine blades **22** are transferred to the hub **20** via the load transfer regions **26**.

**[0046]** As shown in the illustrated embodiment, the wind turbine **10** may also comprise a turbine control system or turbine controller **36** located within the nacelle **16** or within the tower **12**. However, it should be appreciated that the turbine controller **36** may be disposed at any location on or in the wind turbine **10**, at any location on the base **14** or generally at any other location communicatively linked

to the wind turbine **10**. The turbine controller **36** may also be divided into a plurality of components divided between a plurality of locations, the components of the turbine controller **36** being communicatively linked and ensuring operation of the wind turbine **10**. The turbine controller **36** may be configured to control the various operating modes of the wind turbine **10** (e.g. start-up and shut-down conditions and sequences). Additionally, the turbine controller **36** may be configured to control a pitch angle or blade pitch of each of the turbine blades **22** relative to the wind direction **28** to control the load and power generated by the wind turbine **10** by adjusting an angular position of at least one turbine blade **22** relative to the wind. For instance, the turbine controller **36** may control the blade pitch of the turbine blades **22**, either individually or simultaneously, by signalling a pitch adjustment system **32** adapted to perform the operation. Pitch axes **34** for the turbine blades **22** are shown. Further, as the wind direction **28** changes, the turbine controller **36** may be configured to control a yaw direction of the nacelle **16** about a yaw axis **38** to position the turbine blades **22** with respect to the wind direction **28**. For example, the turbine controller **36** may signal a yaw drive mechanism (not shown) of the nacelle **16** in order for the latter to rotate the nacelle **16** about the yaw axis **38**.

**[0047]** During operation of the wind turbine **10**, wind strikes the turbine blades **22** from a wind direction **28**, which causes the rotor **18** to rotate about an axis of rotation **30** and to define a virtual rotation disk (see Figs. 4A-4C): a space occupied by the turbine blades **22** as they rotate. As the turbine blades **22** are rotating and subjected to centrifugal forces, the turbine blades **22** are also subjected to various forces and bending moments. As such, the turbine blades **22**, and therefore the rotation disk, may deflect from a neutral, or non-deflected, position, hence from a flat rotation disk, to a deflected position, hence a domed rotation disk. The non-deflected blade clearance represents the distance between the turbine blades **22** when in front of the tower **12** (hence a portion of the inner face of the rotation disk) and the tower **12** when the turbine blades **22** are in a non-deflected position. However, forces and bending moments acting on the turbine



blades **22** may cause the turbine blades **22** to deflect towards the tower **12**, reducing the overall blade clearance, especially close to the tip of the turbine blades **22**. As aerodynamic loads increase, excessive forces and bending moments can cause deformation of the rotation disk and therefore of one or more sections of the turbine blades **22**, specifically the tip, and cause one or more of the turbine blades **22** to strike the tower **12** resulting in significant damage and downtime.

**[0048]** Fig. 2 illustrates an embodiment of a system for monitoring the blade deflection of turbine blades **22** of a wind turbine **10** as mounted to a wind turbine **10** under the nacelle **16**. The system comprises a position detecting apparatus **40** and a deflection controller **44** (herein illustrated as mounted somewhere in the nacelle **16**). The position detecting apparatus **40** is configured to acquire data, comprising a plurality of distances, relating directly to the position of a turbine blade **22** traveling relatively in front of the tower **12**, in a detection area **50**, and to transmit the data to the deflection controller **44**. The deflection controller **44** is configured to receive the data from the position detecting apparatus **40** and to process the data to determine the deflection of the turbine blades **22**, hence deflection of the rotation disk and blade clearance, as will be described in greater detail below. As indicated above, the position detecting apparatus **40** is configured to acquire data, namely distances and/or presence, of a turbine blade **22** when it is located in a detection area relatively in front of the tower **12**.

**[0049]** It should be readily appreciated that the position detecting apparatus **40** does not require any component in or on the turbine blade **22**, and therefore can be installed on existing wind turbines **10**. The position detecting apparatus **40** acquires data relating directly to the position of a turbine blade **22** with such existing wind turbines **10** without requiring modification of the turbine blades **22** of the wind turbine **10**. Furthermore, as will be discussed herein, the position detecting apparatus **40** is adapted to efficiently and reliably operate in variable weather conditions, including rain, snow, fog, clouds, etc.



**[0050]** Back to Fig. 2, the wind turbine **10** comprises a position detecting apparatus **40** comprising a plurality of position detection components **42** (see Fig. 3) directed at least partially at a section of the rotation disk, and more specifically the section substantially in front of the tower **12**.

**[0051]** More specifically, each one of the position detection component **42** consists in a LiDAR (Light Detection and Ranging) component adapted to monitor thus detect the presence and the distance to an object, namely a turbine blade **22**, within a distinct field of detection along a precise orientation, and to collect distances. Thus, LiDAR must be understood as a surveying or scanning method and/or device that measures distance to a target by illuminating that target with a pulsed laser light, and measuring the reflected pulses with a sensor. In consequence, a LiDAR device comprises a light source (component illuminating the target) and a sensor (measuring the reflected pulses).

**[0052]** In the present case, seventeen (17) such LiDARs are mounted together as distinct position detection components **42** and are directed at different angles toward the rotation disk to collect distance data. The angles are selected, as illustrated on Fig. 2, to detect distance of segments along the length of a turbine blade **22** from a position relatively close to the rotatable hub **20** (e.g., a location close to two third of the turbine blade length from the hub **20**) to an angle wherein reading of a distance/presence of the tip of a turbine blade **22** only occurs when the turbine blade **22** presents at least a predetermined level of deflection. The angles may be defined so as to generate a relatively continuous vertical spread detection area extending from the first angle to the second angle relative to a horizontal plane. According to an embodiment, the segments are distinct and separated from each other.

**[0053]** In another embodiment, the position detecting apparatus **40**, based on above described use of a multichannel LiDAR, would not provide a sufficient ranging distance capability within the time of passage of the blade tip **35** in its field of view or field of detection. This might result from the power of the light source

from the detecting apparatus **40** being distributed over a large area, or field of view, or field of detection. In this case, different position detecting apparatus **40**, or LiDARs, having distinct fields of views (a.k.a. fields of detection), are combined. Therefore, a first mono-component position detecting apparatus **40**, a.k.a. mono-channel LiDAR, is used to detect a minimum deflection level of the blade tip **35** at a specific position with respect to a distance from the tower **12**. This first mono-component position detecting apparatus **40** preferably has a smaller field of view and a more powerful light source to perform measurement of the position of the turbine blade **22** of farther distances. Then, an additional position detecting apparatus **40**, with one or multiple detection components **42**, such as a mono-channel LiDAR or a multichannel LiDAR, is used to assess the maximum deflection of the blade tip **35** from the measured distances read at other angles and providing positions of the turbine blade **22** along its length closer to the hub **20**. The position of the blade tip **35** with respect to the tower **12** is obtained from extrapolation of the shape of the turbine blade **22** measured at different points along the turbine blade **22**. The other position detecting apparatus **40**, thus the other position detecting components **42**, detects the position of the turbine blade **22** at shorter distance, or distances, than the first mono-component position detecting apparatus **40**. Accordingly, this distance, or these distances, can be obtained even if the light source is distributed over a larger area than the area covered by the first mono-component position detecting apparatus **40**.

**[0054]** It is noted that the angle for channel 17 of the LiDAR is closer to a horizontal plane and channel 1 of the LiDAR is closer to a vertical plan. Furthermore, according to an embodiment, the channels 1 to 17 are colinear.

**[0055]** The distances measured from the position detecting components **42** of the first position detecting apparatus **40** and the additional position detecting apparatus **42** are processed together to get a better assessment of the position of the blade tip **35**, and thus distance of the blade tip **35** with respect to the tower **12**.



**[0056]** LiDAR technology, and more specifically multichannel LiDARs, features advantageous characteristics for use in the present context. Since the turbine blades **22** are spinning, the speed of a section of a turbine blade **22** increases as distance of the segment of a turbine blade **22** relatively to the axis of rotation **30** increases. The LiDAR, with a data collection frequency of between 50 Hertz and 100 Hertz, is able to collect data both from a segment of a turbine blade **22** close to the axis of rotation **30** and from a segment close to the blade tip **35**. Further, since the surface of the detection area associated with a LiDAR increases as the distance of the detected object increases, the detection area which crosses the tip of the turbine blade **22** is wider than the detection area which crosses another segment of the turbine blade **22** closer to the rotatable hub **20**. Therefore, a turbine blade **22** has a longer path to travel to cross completely the detection area at the blade tip **35**, which allows correct detection in spite of the higher speed of the blade tip **35**.

**[0057]** According to an embodiment, the system comprises at least one position detecting apparatus **40** mounted on a turbine blade **22** close to the rotatable hub **20**. The position detection components **42** of the turbine-blade mounted position detecting apparatus **40** are directed at least partially and generally toward the tower **12** and the ground to be able to detect deflection of the blade tip **35** of the turbine blade **22** on which is mounted the position detecting apparatus **40**. Such measurement is performed by measuring/detecting the tower **12** and/or the blade tip **35** of the turbine blade **22** depending on the position detection component **42**. According to an embodiment, the system comprises a position detecting apparatus **40** per turbine blade **22**.

**[0058]** Regarding Fig. 3, a graph illustrates blade clearance calculated from the data collected by the different position detection components **42** of embodiments mounted under the nacelle **16** comprising either one or more position detecting apparatus **40**. References from 1 to 17 are associated with distinct position detection components **42**. The top line **61** indicates the blade



clearance computed based on the distance read by the position detection component **42** when the turbine blades **22** undergo no deflection. The middle line **62** indicates the blade clearance computed based on the distances read by the position detection components **42** when the turbine blades **22** undergo deflection within an acceptable range. The bottom line **63** indicates the blade clearance computed based on the distances read by the position detection components **42** when the turbine blades **22** undergo deflection above an acceptable range (i.e., critical).

**[0059]** It must be noted that the position detection components **42** associated with references 1 to 5 read no distances in a no deflection condition (no top line **61**). As blade deflection increases, the distances read by the position detection components **42** of associated references 17 to 6 decrease. Gradually, the position detection components **42** of associated references 5 to 3 become capable of capturing distance data of a segment of the turbine blades **22** as the turbine blades **22** deflect and appear in the field of view, hence the associated detection area, of these position detection components **42**. It must be noted that the data provided in Fig. 3 are not distance data as read by the position detection components **42**, but rather calculated blade clearance between a corresponding segment of the turbine blade **22** and the tower **12** based on distance data collected by the position detection components **42** and formula based on angles, known position of the corresponding detection area segments and tower segments.

**[0060]** The rotation disk **70** in different conditions is further illustrated on Figs. 4A-C. For illustration, Fig. 3 - lines 61-63 and Fig. 4A show the position detection components **42** of references 17 to 6 providing data in any conditions, namely when the rotation disk **70** shows no deformation (area **71**), when the rotation disk **70** shows deformation within an acceptable range of deformation (area **72**) and when the rotation disk **70** shows deformation above the acceptable range of deformation (area **73**). Fig. 3 - lines 62-63 and Fig. 4B show additional position detection components **42** providing data only when the rotation disk **70** is

showing deformation within an acceptable range of deformation (the rotation disk **70** having entered the area **72**). Fig. 3 - lines 63 and Fig. 4C show further position detection components **42** providing data when deflection of the turbine blades **22** result in the rotation disk **70** showing deformation above the acceptable range of deformation (the rotation disk **70** having entered area **73**), and thus the turbine blades **22** being in dangerous conditions.

**[0061]** Accordingly, as explained in relation with the position detection components **42** associated with references 1 to 5 on Fig. 3, according to an embodiment, the position detection components **42** collect Boolean data, namely whether or not a portion of the detection area is crossed by a section of a turbine blade **22** being or close to the blade tip **35**. According to that embodiment, based on the identification and angles of the different position detection components **42** which provide positive data, the deflection controller **44** is able to determine a level of deflection of the turbine blades **22**, a.k.a. a level of deformation of the rotation disk **70**. According to an embodiment, comparison of the data collected by the position detection component **42** allows to establish validity of the collected data and to determine an actual range of deflection of the turbine blades **22**.

**[0062]** According to an embodiment, as illustrated on Figs. 5A-C, the position detection components **42**, additionally to being spread in different vertical angles relative to a vertical plane, is spread horizontally to cover a wider angle, for example about 3 degrees. Accordingly, with this embodiment a turbine blade **22** takes longer to cross completely the 3-degree detection area, providing more time for one or more position detection components **42** to collect distance data. Therefore, that configuration ensures that at least a portion of the position detection components **42** having detection area segments associated therewith that are close to the blade tip **35** would be able to collect distance data at each passage of a turbine blade **22**, and that regardless of the speed at which the blade tip **35** travels across the detection area.



**[0063]** According to an embodiment, a plurality of position detection components **42** are spread in multiple channels horizontally, such as to have one channel aligned in front of the turbine tower **12** while another channel pointing at a position where the turbine blade **22** is not yet in front of the tower **12** and/or another channel pointing at a position wherein the turbine blade **22** has passed the tower **12**. Therefore, that configuration provides information on some local deflection effect that can occur when the turbine blade **22** passes in front of the tower **12**. This effect is known to happen from aerodynamic acceleration of air that is deviated and accelerated when passing around the tower **12**. The supplemental deflection effect can be measured by comparing the distance measured when the turbine blade **22** passes in front of the tower **12** with the distance measured when the position of the turbine blade **22** is not in front of the tower **12**.

**[0064]** Furthermore, this configuration described in the above embodiment can be combined with other configurations in order to get information of the overall shape of deflection of the turbine blade **22** in front of the tower **12** as well as the dynamic, or temporal, blade deflection changes that are occurring in the vicinity of the tower **12**.

**[0065]** According to an embodiment, a blade deflection measurement per turbine blade **22** is performed and individually associated with the turbine blades **22** in a processing manner. According to an embodiment, the wind turbine **10** comprises a blade position detection means, such as means to measure the angle of rotatable hub **20** with set angles individually associated with each of the turbine blades **22**, an individual measurement of the orientation of the turbine blades **22**, close-field or optical detection means comprising in combination a detector and identification components located on the turbine blades **22** with the detector detecting and identifying the turbine blade **22**, hence turbine blade position, when the turbine blade **22** is passing in front of the detector, etc. The blade position detection means is communicatively linked to the deflection controller **44** to signal position and/or identification of a turbine blade **22** to associate with deflection



collection data. The deflection controller **44** further determines individually the deflection of each of the turbine blades **22** and may trigger individually for each of the turbine blades **22** correction(s) (e.g. altering the blade pitch) based on their individual associated collected data. It can be used to identify structural weaknesses of a specific turbine blade **22**. Furthermore, that embodiment provides a solution to detect system failure through comparison of blade detection data by the position detecting apparatus **40** to intended data (e.g. when one turbine blade **22** passes in the detection area, thus when data is intended to be acquired by the position detecting apparatus **40**).

**[0066]** According to such an embodiment, Figs. 4A-C may illustrate the level of deflection of three turbine blades **22** of the same wind turbine **10** during the same rotation cycle. For instance, based on actual configurations (e.g. pitch angle) and structural weaknesses, the three turbine blades **22** may present different levels of deflection, including as illustrated having them in distinct deflection levels **71, 72, 73** of the rotation disk **70**, thus in three distinct current operating conditions.

**[0067]** According to an embodiment, the position detecting apparatus **40** is mounted under the nacelle **16** to be protected, or partially shielded, from bad weather (snow, rain, etc.) by the nacelle **16**. The detection position apparatus is further mounted to the nacelle **16**, close to the tower **12** (hence away from the turbine blades **22**) to have an optimum viewing angle of the turbine blades **22** and therefore extend the angle of detection. According to other embodiments, the position detecting apparatus **40** is mounted to the nacelle **16**, either on top or on the side of the nacelle **16**.

**[0068]** According to embodiments, the system, embedded in the position detection apparatus **40** or in the nacelle **16**, comprises an inclinometer **82** (see Figs. 6A-C) providing inclination data, and an accelerometer **84** (see Figs. 6A-C) providing proper acceleration data.

**[0069]** Some of the proposed embodiments are intended to get information on the relative position of the blade tip **35** with respect to the turbine tower **12** to prevent collision between them, and thus prevent related costs. Configurations that use position detecting apparatus **40** mounted to the hub **20** or nacelle **16** in these cases, not only need the deflection measured of the turbine blades **22**, but also need to take into account possible inclination of the hub **20** or nacelle **16** with respect to the tower **12**. It is known that towers **12** are designed to bend under high wind speed (source: Nicholson, John Corbett. "Design of wind turbine tower and foundation systems: optimization approach." MS (Master of Science) thesis, University of Iowa, 2011. <http://ir.uiowa.edu/etd/1042>) to prevent mechanical fatigue or to avoid very large infrastructure that would be required to prevent such bending. In this case, an inclinometer **82** and an accelerometer **84** can be used nearby the position detecting apparatus **40** to assess the extent of the bending of the tower **12** and also the relative displacement of the nacelle **16**, or hub **20**, with respect to the position of the tower **12** where the blade tip **35** can hit it. The information provided by the accelerometer **84** and inclinometer **82** can then be used to assess the distance from the blade tip **35** to the tower **12** by using some models for the tower bending. An example of the impact of the inclination of the nacelle **16** on the clearance between the blade tips **35** and the tower **12** is illustrated on Figs. 6A-C, with Fig. 6A illustrating the nacelle **16** at its nominal inclination level, a.k.a. zero-degree angle. In this case, while the turbine blade **22** is deflected, there is not in contact of the blade tip **35** with the tower **12**. Fig. 6B illustrates the nacelle **16** inclined forward, a.k.a. toward the tower **12**, and displays a turbine blade **22** that would hit the tower **12**. Finally, Fig. 6C illustrates the nacelle **16** inclined backward and thus having a greater clearance between the turbine blade tip **35** and the tower **12**. These schematic representations do not reflect the real life, since the tower **12** bending is not represented, but they illustrate the effect of the inclination of the nacelle **16** on the clearance between the turbine blade tip **35** and the tower **12**.



**[0070]** Regarding the detection directions of the position detection apparatus **40**, according to embodiments, the position detecting apparatus **40** is mounted to the turbine blade **22** as above described, to the rotatable hub **20**, or to the tower **12**, with the position detection components **42** being directed in a suitable manner according to the mounting location of the position detecting apparatus **40** to have either the turbine blades **22** or the tower **12** directed thereto.

**[0071]** According to embodiments, the position detecting apparatus **40** is protected from bad weather conditions by a weather-proof enclosure (not shown) housing it. The weather-proof enclosure is mounted in an appropriate fashion and provides suitable window(s) for the position detection components **42** to be directed suitably in an operational fashion.

**[0072]** According to an embodiment, the deflection controller **44** is mounted inside the nacelle **16**, with the deflection controller **44** and the position detecting apparatus **40** communicatively linked therewith. That mounting configuration of the deflection controller **44** protects the deflection controller **44** from bad weather conditions while ensuring communication with the position detecting apparatus **40**.

**[0073]** According to embodiments, inclinometer(s) **82** and/or accelerometer(s) **84** is/are mounted to position detecting apparatus **40**, the nacelle **16** and/or the hub **20**. The inclinometer(s) **82** is/are mounted in an operable fashion to provide at least one of: inclination of the position detecting apparatus **40**, inclination of the nacelle **16** and inclination of the hub **20**. The accelerometer(s) **84** is/are mounted in an operable fashion to provide at least one of: proper acceleration data relative to the tower **12**, proper acceleration data relative to the nacelle **16**, proper acceleration data relative to the hub **20**, and proper acceleration data relative to the turbine blades **22**. The inclinometer(s) **82** and/or accelerometer(s) **84** is/are communicatively linked with the deflection controller **44**.

**[0074]** According to an embodiment, the power levels associated with each of the position detection components **42** are non-uniform. More precisely, the



power level assigned to a position detection component **42** detecting a segment close to the rotatable hub **20** is lower than the power level assigned to a position detection component **42** (of references 5 to 1) associated with a detection area segment closer to the blade tip **35**, or to the blade tip **35** of the turbine blades **22** in any deflection condition or in a deflected condition. The setting of the power levels to be assigned, according to an embodiment, involves a different number of LEDs (Light Emitting Diodes), or laser diodes, powering the different position detection components **42**. According to an embodiment, the power ratio between two position detection components **42** would be above about 5 to 1. According to an embodiment, the power ratio between two position detection components **42** would be above about 10 to 1. According to another embodiment, the power ratio between two position detection components **42** would be above about 20 to 1. According to yet another embodiment, the power ratio between two position detection components **42** would be above about 30 to 1.

**[0075]** According to an embodiment, the width of the detection area, hence the detection spread angle of a position detection component **42** would be non-uniform. More precisely, the detection spread angle of the position detection component **42** oriented to detect a segment of a turbine blade **22** close to the rotatable hub **20** would have in a lower value than the detection spread angle of a position detection component **42** (of references 5 to 1) oriented to detect a segment closer to the blade tip **35**, or the blade tip **35** of the turbine blades **22** in any deflection condition or in a deflected condition. According to an embodiment, the detection spread angle ratio between two position detection components **42** would be above about 2 to 1. According to another embodiment, the detection spread angle ratio between two position detection components **42** would be above about 5 to 1. According to yet another embodiment, the detection spread angle ratio between two position detection components **42** would be above about 10 to 1.

**[0076]** As a practical example of a realization and as illustrated on Figs. 5A-C, a turbine blade **22** of 37 meters in length spinning at 20 rotations per minute would cross a set detection area of about 2 meters in width (with the set horizontal detection angle being about 3 degrees) at the blade tip **35** in about 18 to 24 msec. The collection frequency of a LiDAR (50 to 100 Hertz) would collect data every about 10 to 20 msec. Thus, the parameters, and particularly the set horizontal detection angle, would ensure that the position detection component **42** is able to collect distance data at probably every spin of the wind turbine **10**.

**[0077]** In other embodiments, the horizontal detection angle may be set wider or narrower, having an impact on the power level set to a position detection component **42** and the probability of detection of a turbine blade **22** at every passage.

**[0078]** In an embodiment, by setting “neighbor” position detection components **42** associated with neighbor detection area segments, a.k.a. fields of detection, at about side-by-side horizontal detection angles, a wider detection area covering a plurality of segments of the rotation cycle of the turbine blades **22** is defined ensuring that at least one of the “neighbor” position detection components **42** detects and collects distance data of a section of (or close to) the high-speed blade tip **35** of the turbine blade **22** at each one of its passages through the neighboring fields of detection. Figures 5a-c illustrates a width a field of detection that is associated with a plurality of “neighbor” position detection components **42** (not shown on the figure), thus covering distinct segments, a.k.a. degrees of an arc, of the rotation cycle of the turbine blades **22**. The “neighbor” position detection components **42** are detecting the blade tip **35** of the turbine blades **22** at different time, thus at different phases of the rotation of the turbine blades **22**.

**[0079]** In case of very bad weather conditions that would reduce the visibility such as fog, snow, heavy rain, and cloud, the accuracy of the distance or deflection measurements could be affected more significantly at the blade tip **35** of the turbine blade **22** than with segments of the turbine blades **22** near the rotatable hub **20**.



Hence, the deflection measurements obtained at all angles in good visibility conditions could be used as a mean to get a calibration of deflections. Also, full waveform LiDAR have the advantage to provide information on the weather conditions that prevail during measurements. The visibility being reduced by the presence of light scattering particles (water droplets or snowflakes) will also appear on the LiDAR signal at distances in between the LiDAR module under the nacelle **16** and the turbine blade **22**. Thus, the presence of such signal above a certain threshold could trigger a mode in the deflection controller **44** that will take the effect of the bad visibility conditions into account. In this case, the calibration performed in good visibility conditions could then be used to extrapolate the resulting deflection at the blade tip **35** of the turbine blade **22** in bad visibility conditions from measurements performed at angles closer to the rotatable hub **20**. This way the deflection controller **44** will provide relevant information that could otherwise be compromised by severe weather conditions.

**[0080]** It must be noted that while camera systems (even standard active imaging systems such as surveillance video systems) are subject to being affected severely in bad visibility conditions such as rain, snow, fog, clouds, full waveform LiDARs are much more robust operation-wise. This comes from the increased processing possibilities that can be implemented from the complete LiDAR signal over time. This allows to discriminate light returned by solid targets such as turbine blades **22** from more diffuse “pollution” targets such as fog and cloud.

**[0081]** While the embodiment described above is making use of LiDAR technology, other similar technologies such as RADAR and LEDDAR™ (e.g. LiDAR based on Light Emitting Diodes) could be used.

**[0082]** Practical applications of the system for monitoring of the deflection of turbine blades **22** of a wind turbine **10** may include integration in a corrective system **90** and/or security system (not shown).



**[0083]** According to an embodiment, the system for monitoring the deflection of turbine blades **22** is configured to trigger a corrective action from the corrective system **90** in order to reduce or stop blade deflection. For example, the deflection controller **44** may be communicatively linked to a system configured to perform a corrective action preventatively, such as by making a one-time parameter change, in anticipation of operating conditions that may present an increased likelihood of a tower strike. Alternatively, the deflection controller **44** may be configured to trigger a corrective action reactively in response to blade deflection of one or more of the turbine blades **22** that exceeds a predetermined blade deflection threshold. Regardless, the corrective action may allow a wind turbine **10** to be adaptable to varying operating conditions which may otherwise result in significant aerodynamic loading on the turbine blades **22**. Thus, the deflection controller **44** may be configured to trigger a corrective action to safeguard against the risk of tower strikes or other blade damage due to excessive turbine blade deflection.

**[0084]** The extent or magnitude of blade deflection required for the deflection controller **44** to trigger a corrective action reactively may vary from wind turbine to wind turbine. For example, the predetermined blade deflection threshold may depend on the operating conditions of the wind turbine **10**, the thickness of the turbine blades **22**, the length of the turbine blades **22** and numerous other factors. For example, the predetermined blade deflection threshold of a turbine blade **22** may be equal to a predetermined percentage of the non-deflected blade clearance. In the event that the deflection controller **44** determines that the turbine blade deflection has exceeded this threshold, it can trigger a corrective action to safeguard against a tower strike. As another example, there may be another threshold related to the change of the blade deflection with time that would be indicative of strong wind bursts building up and that could prevent proper assessment of blade deflection on an instantaneous basis to implement corrective action in fast enough time to safeguard against a tower strike. In the event that the

deflection controller **44** determines that the turbine blade deflection change over time has exceeded this other threshold, it can trigger a corrective action to safeguard against a tower strike. In another embodiment, differences in measured deflection between different blades is used by the deflection controller **44** as a threshold to trigger possible diagnostic of a specific blade structural defect and to operate the wind turbine **10** with operating parameters that will prevent the defective turbine blade **22** to hit the tower **12** or the blade structural defect to deteriorate.

**[0085]** The corrective actions triggered by the deflection controller **44** may take many forms.

**[0086]** In an embodiment, the triggered corrective action comprises altering the blade pitch of one or more turbine blades **22** for a partial or full revolution of the rotor **18**. As indicated above, this may be accomplished by signalling a pitch adjustment system **32**. Generally, altering the blade pitch of a turbine blade **22** reduces blade deflection by increasing out-of-plane stiffness.

**[0087]** In an embodiment, the triggered corrective action comprises modifying the blade load on the wind turbine **10** by either increasing or decreasing the torque demand on the electrical generator (not illustrated) positioned within the nacelle **16**. This modification of the load demand would result in a modification of the rotational speed of the turbine blades **22**, thereby modifying, and potentially as intended reducing the aerodynamic loads acting upon the surfaces of the turbine blades **22**.

**[0088]** In an embodiment, the triggered corrective action comprises yawing the nacelle **16** to change the angle of the nacelle **16** relative to the wind direction **28** (see Fig. 1). A yaw drive mechanism (not shown) is typically used to change the angle of the nacelle **16** so that the turbine blades **22** are properly angled with respect to the prevailing wind. For example, pointing the leading edge of a turbine



blade **22** upwind can reduce loading on the turbine blade **22** as it passes the tower **12**.

**[0089]** In an embodiment, the triggered corrective action comprises applying a mechanical break to the rotatable hub **20** to stop the rotation of the turbine blades **22**; that solution is only selected in exceptional conditions. This corrective action is usually, if not always, associated with one of the other above correction actions.

**[0090]** It should be readily appreciated, however, that the deflection controller **44** needs to be communicatively linked, directly or indirectly, to one such system able to perform the corrective actions described above and may generally trigger any corrective action designed to reduce blade deflection. Additionally, the deflection controller **44** may be configured to trigger multiple corrective actions simultaneously or in sequence, which may comprise one or more of the corrective actions described above.

**[0091]** Furthermore, the deflection controller **44** may be configured to trigger a particular corrective action in response to certain operating conditions and/or operating states of the wind turbine **10**. Thus, in one embodiment, the deflection controller **44** may be configured to selectively trigger a particular corrective action depending upon intrinsic parameters (turbine blade deflection data) and extrinsic parameters transmitted by other components and/or systems (wind speed, turbine blade speed, current load, etc.). For example, during certain wind conditions, turbine blade deflection may be most effectively reduced by altering the blade pitch of the turbine blades **22**. Accordingly, during such conditions, the deflection controller **44** may be configured to receive extrinsic parameters (wind speed data), to determine the best response based on these parameters, and to trigger alteration of the blade pitch of one or more of the turbine blades **22** when the determined blade deflection exceeds a predetermined threshold, such as a predetermined percentage of the non-deflected blade clearance. However, in the event that blade deflection is below this predetermined threshold, data processing



by the deflection controller **44** may result in triggering a different corrective action. This may be desirable, for example, when an alternative corrective action can sufficiently reduce blade deflection while causing less of an impact on the amount of power generated by the wind turbine **10**. Accordingly, such a configuration can improve the efficiency of a wind turbine **10** by ensuring that the corrective action performed is proportional to the severity of the blade deflection.

**[0092]** Referring to Fig. 7, a method of operation comprises the following steps:

**[0093]** At step **S102**, the system is configured to detect deflection data as turbine blades pass in the detection area, and to transmit deflection data to the deflection controller.

**[0094]** At step **S104**, the system may be configured to detect position, presence and/or identification of a turbine blade that passes in the detection area. The data is transmitted, when such components are present, in real time or close to real time to the deflection controller. The latter may thus associate the turbine blade identification with the deflection data.

**[0095]** At step **S106**, the system may be configured to collect inclination data and/or proper acceleration data that provides information on at least one of the inclination of the nacelle or the hub, movements of the nacelle or the hub, and bending or movements of the tower. The data is transmitted, when such components are present, in real time or close to real time to the deflection controller. The latter may thus process changes in the intrinsic environmental conditions (angle of the anchoring of the turbine blades, vibration in the components, and bending of the tower) for these intrinsic environmental conditions to be taken into account in the processing of the clearance between the turbine blades and the tower.

**[0096]** At step **S108**, the system may be configured to receive extrinsic data, such as wind speed data, to be processed with the identified data transmitted at steps **S102**, **S104** and **S106**.

**[0097]** At step **S112**, the system processes the received data and determine a current operating condition based both or either of a) received data and presence of particular data associated with specific deflection levels of the turbine blades, and b) processing the received data and potentially comparing the received data with parameters.

**[0098]** Determining a current operating condition in the present step means determining if the wind turbine is currently, or based on last data received by the deflection controller, in acceptable operating conditions, a.k.a. if the rotation disk, and thus the turbine blades are within the acceptable range of deformation, or not. The determination of the current operating conditions is used to determine if, when and what corrective action(s) must be triggered.

**[0099]** Processing the presence of some data may include determining fault associated with some detection means, hence lack of signal, or detecting deflection signal that is associated with a turbine blade being deflected of at least a predetermined percentage, as illustrated through Figs. 3, Figs. 4A-C and Figs. 6A-C.

**[00100]** Processing the received data may comprise comparing the deflection data to the blade position data to single out turbine blade weakness, comparing deflection data of distinct turbine blades to monitor rotation disk deformation, and comparing deflection data of the turbine blades over a plurality of cycles to detect data variation that may be due, for instance, to vibrations.

**[00101]** Processing the received data and comparing the received data with parameters may comprise, as illustrated through Figs. 3, Figs. 4A-C and Figs. 6A-C the comparison of the received data, or of the clearance determined based on the received data, to pre-set operation parameters such as deflection percentages.



**[00102]** At step **S122**, the method may comprise, based on the result of the processing of the collected data, identifying a condition, such as a percentage of deflection, specific to an identified turbine blade.

**[00103]** At step **S124**, the method may comprise, based on the result of the processing of the collected data, identifying a condition, such as a) malfunction of a detector, b) weather condition preventing the system to operate adequately, specific to a component of the system, and c) communication problems between components of the system for example.

**[00104]** At step **S126**, the method may comprise, based on the result of the processing of the collected data, identifying a condition, such as general level of deflection, that applies to the rotation disk, hence to the turbine blades.

**[00105]** At step **S128**, the method may comprise, based on the result of the processing of the collected data, identifying that the wind turbine operates in acceptable conditions. Such conclusion may be regularly registered for maintenance purposes.

**[00106]** At step **S132**, the method may comprise to trigger one of the available corrective actions above discussed. The determination of the corrective action(s) to trigger is based on a corrective algorithm taking into account a series of parameters such as the determined current operating conditions, the severity of the identified current operating conditions, the size and configuration of the wind turbine, the components of the system, the components of the wind turbine, a corrective history, raw data from which result the determination of the current operating conditions, etc. Such a corrective action may include operative actions (such as changes in the pitch angle) and non-operative actions (such as signals transmitted to a maintenance central).

**[00107]** While preferred embodiments have been described above and illustrated in the accompanying drawings, it will be evident to those skilled in the art that modifications may be made without departing from this disclosure. Such



modifications are considered as possible variants comprised in the scope of the disclosure.

File No. P4002PC00

**CLAIMS:**

1. A system for monitoring deflection of turbine blades of a wind turbine comprising a tower, wherein the turbine blades comprise segments along a length of the turbine blades, the system comprising:
  - a position detection apparatus mounted to the wind turbine apart from the turbine blades, the position detection apparatus comprising position detection components each detecting a presence or absence of a corresponding one of the segments of the turbine blades; and
  - a deflection controller configured to receive the presence or absence detection and to use the presence or absence detection to determine a distance of each of the segments of the turbine blades relative to the tower, whereby the distance of each of the segments of the turbine blades relative to the tower is representative of the deflection of the turbine blades.
2. The system of claim 1, wherein the position detection components comprise a pulsed laser source and a sensor.
3. The system of claims 1 or 2, wherein each one of the position detection components is set at a distinct angle relative to a horizontal plane.
4. The system of any one of claims 1 to 3, wherein each one of the position detection components is associated with a distinct channel resulting in a plurality of colinear channels.
5. The system of any one of claims 1 to 4, wherein a power ratio of a power associated with a first one of the position detection components over a power associated with a second one of the position detection components is above about 5 to 1.



File No. P4002PC00

6. The system of any one of claims 1 to 4, wherein each of the position detection components are set to a spread angle, and wherein the spread angle associated with a first one of the position detection components is different from the spread angle associated with a second one of the position detection components.

7. The system of claim 6, wherein a spread angle ratio of the spread angle associated with the first one of the position detection components over a spread angle associated with the second one of the position detection components is above about 2 to 1.

8. The system of any one of claims 1 to 7, wherein the wind turbine further comprises a nacelle and wherein the position detection apparatus is mounted under the nacelle.

9. The system of claim 8, further comprising at least one of an inclinometer and an accelerometer; and wherein at least one of the inclinometer and accelerometer provides data regarding bending of the tower or inclination of the nacelle.

10. The system of any one of claims 1 to 9, further comprising a corrective system, wherein the deflection controller triggers actions to be performed by the corrective system upon detection of deflection of the turbine blades outside an acceptable range.

11. The system of claim 10, wherein the wind turbine comprise a nacelle mounted to the tower, a hub mounted to the nacelle, with the turbine blades mounted to the hub, wherein the corrective system is adapted to perform at least

File No. P4002PC00

one of:

- altering pitch of at least one of the turbine blades;
- modifying blade load by modifying torque demand over the hub;
- modifying yawing of the nacelle; and
- applying a break on the hub.

12. The system of any one of claims 1 to 11, wherein the position detection apparatus further comprises a plurality of neighbor detection components each collecting data regarding a distinct lateral neighbor field of detection each corresponding to a distinct segment of rotation cycle of the turbine blades, whereby each of the neighbor detection components monitors a passage of blade tips of the turbine blades travelling through an associated distinct lateral neighbor field of detection at a distinct phase of a rotation cycle of the turbine blades.

13. A system for monitoring deflection of turbine blades each having a blade tip of a wind turbine, the system comprising:

a detection apparatus mounted to the wind turbine apart and distant from the turbine blades, the detection apparatus comprising a plurality of neighbor detection components each collecting data regarding a distinct lateral neighbor field of detection each corresponding to a distinct segment of rotation cycle of the turbine blades, whereby each of the neighbor detection components monitors a passage of the blade tips of the turbine blades travelling through an associated distinct lateral neighbor field of detection at a distinct phase of a rotation cycle of the turbine blades when the turbine blades feature a level of deflection over a predetermined level; and

a deflection controller configured to receive the collected data and to determine a deflection condition of the turbine blades accordingly.



File No. P4002PC00

14. The system of claim 13, wherein the neighbor detection components comprise a pulsed laser source and a sensor.

15. The system of claims 13 or 14, wherein the distinct lateral neighbor fields of detections correspond to field of views of the neighbor detection components set at distinct angles relative to a vertical plane.

16. A method of monitoring clearance between turbine blades and a tower of a wind turbine, wherein the turbine blades comprise segments along a length of the turbine blades, the method comprising:

detecting, using a position detection apparatus mounted to the wind turbine apart and distant from the turbine blades, presence or absence of a corresponding one of the segments of the turbine blades; and  
processing the detected presence or absence detection to determine a distance of each of the segments of the turbine blades relative to the tower, whereby the distance of each of the segments of the turbine blades relative to the tower is representative of the clearance of the turbine blades.

17. The method of claim 16, further comprising at least one of:  
detecting an angular position of the turbine blades;  
associating detected presences or absences with a specific one of the turbine blades; and  
detecting anomalies associated with one of the turbine blades relative to the tower.

18. The method of claims 16 or 17, further comprising detecting at least one of inclination data and proper acceleration data, wherein the step of processing further comprises processing the at least one of inclination data and proper acceleration data.

File No. P4002PC00

19. The method of any one of claims 16 to 18, further comprising receiving data extrinsic to the wind turbine, wherein the step of processing further comprises establishing parameters based at least on the extrinsic data.

20. The method of any one of claims 16 to 19, wherein the step of processing further comprises comparing the clearance with parameters, and wherein the method further comprises:

identifying a faulty condition based on comparison of the clearance with the parameters; and  
triggering corrective actions to prevent the turbine blades to hit the tower.



1/7

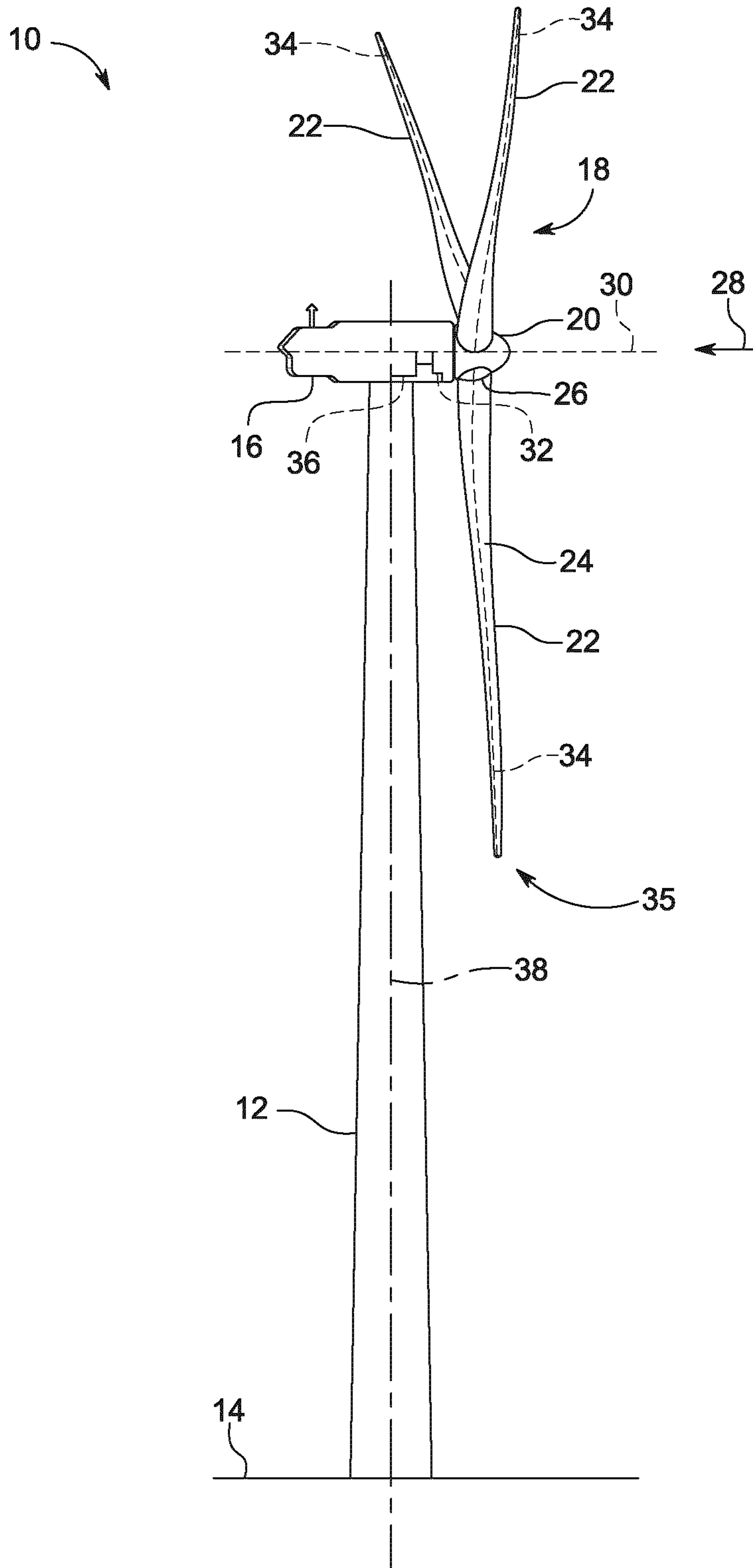

FIG. 1

2/7

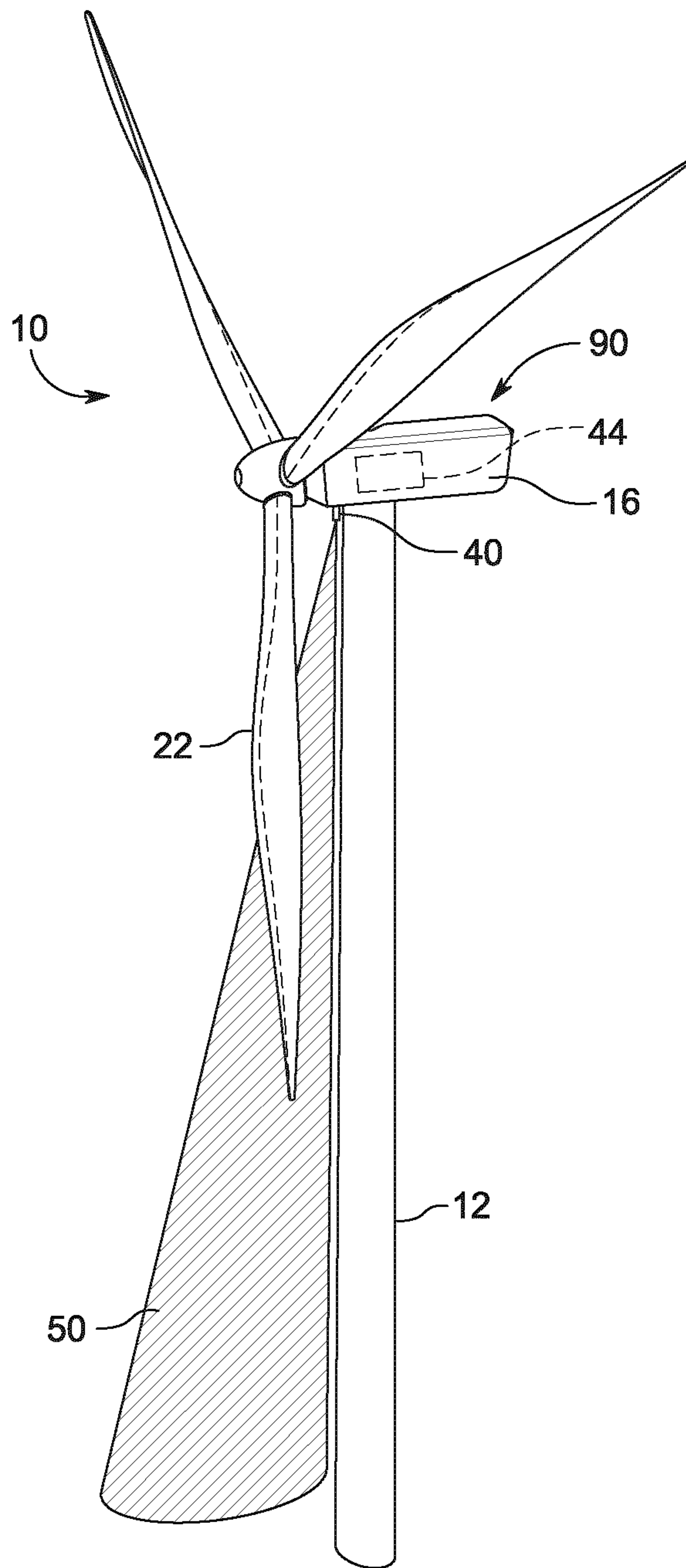

FIG. 2

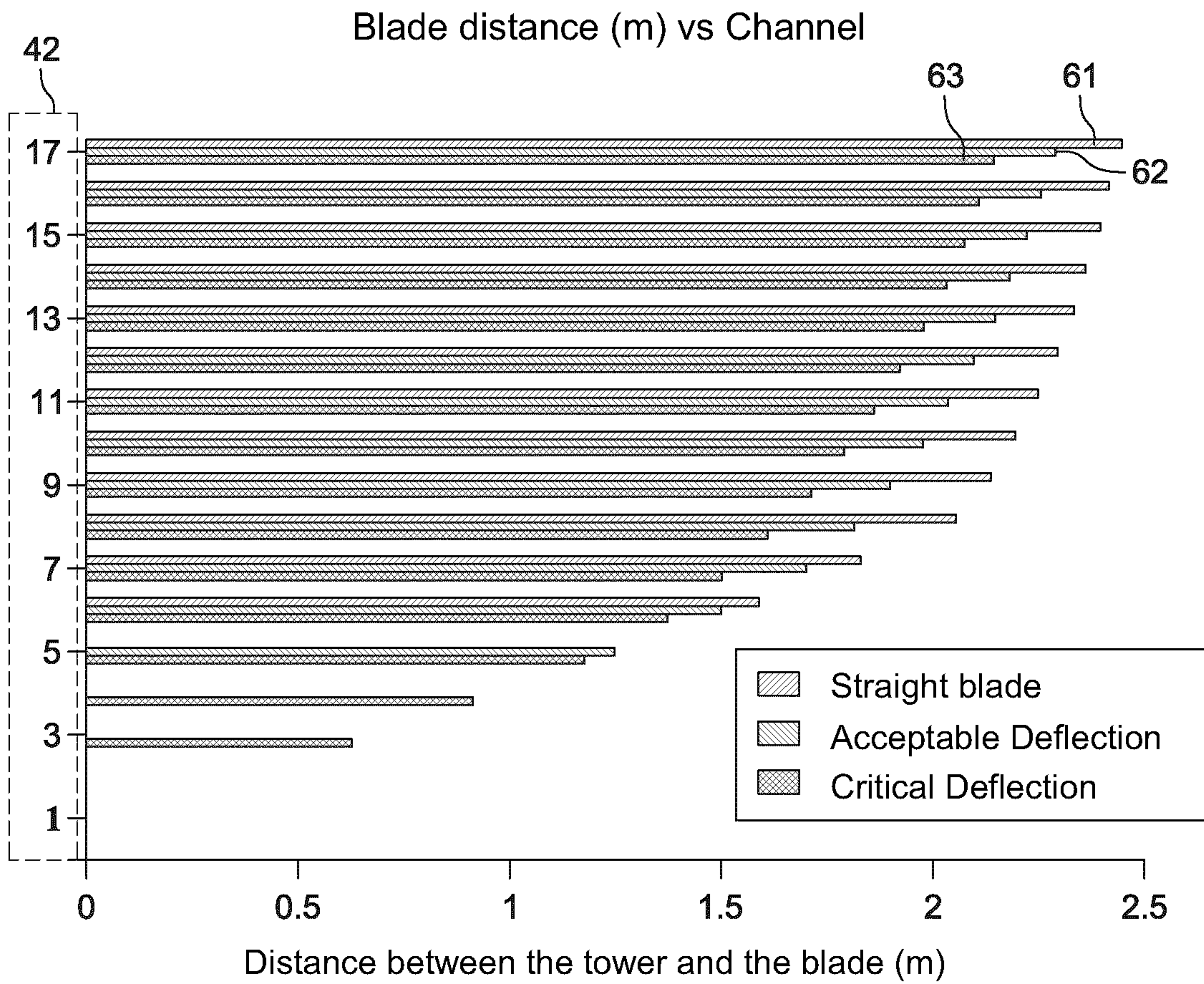

FIG. 3



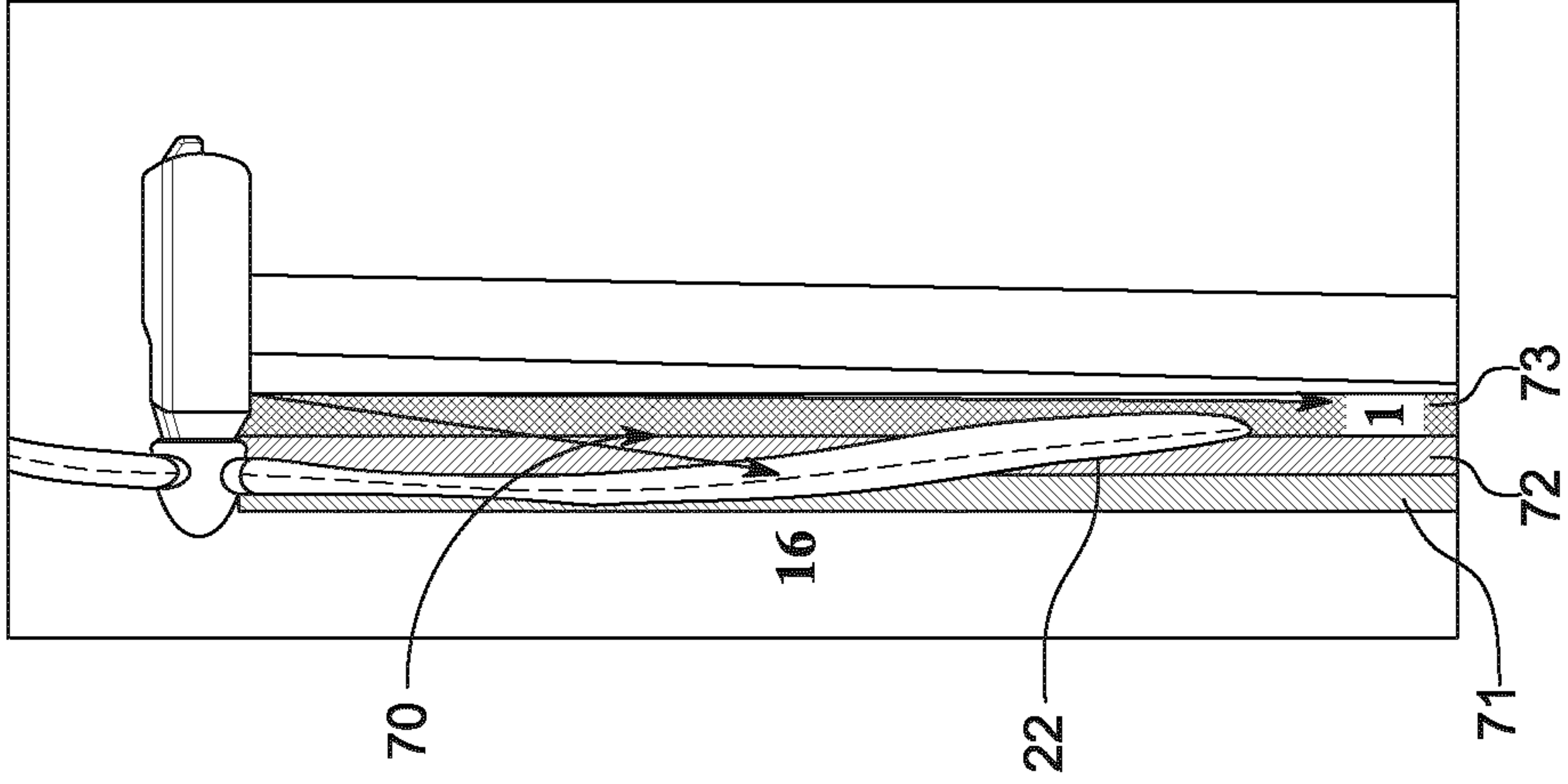

FIG. 4C

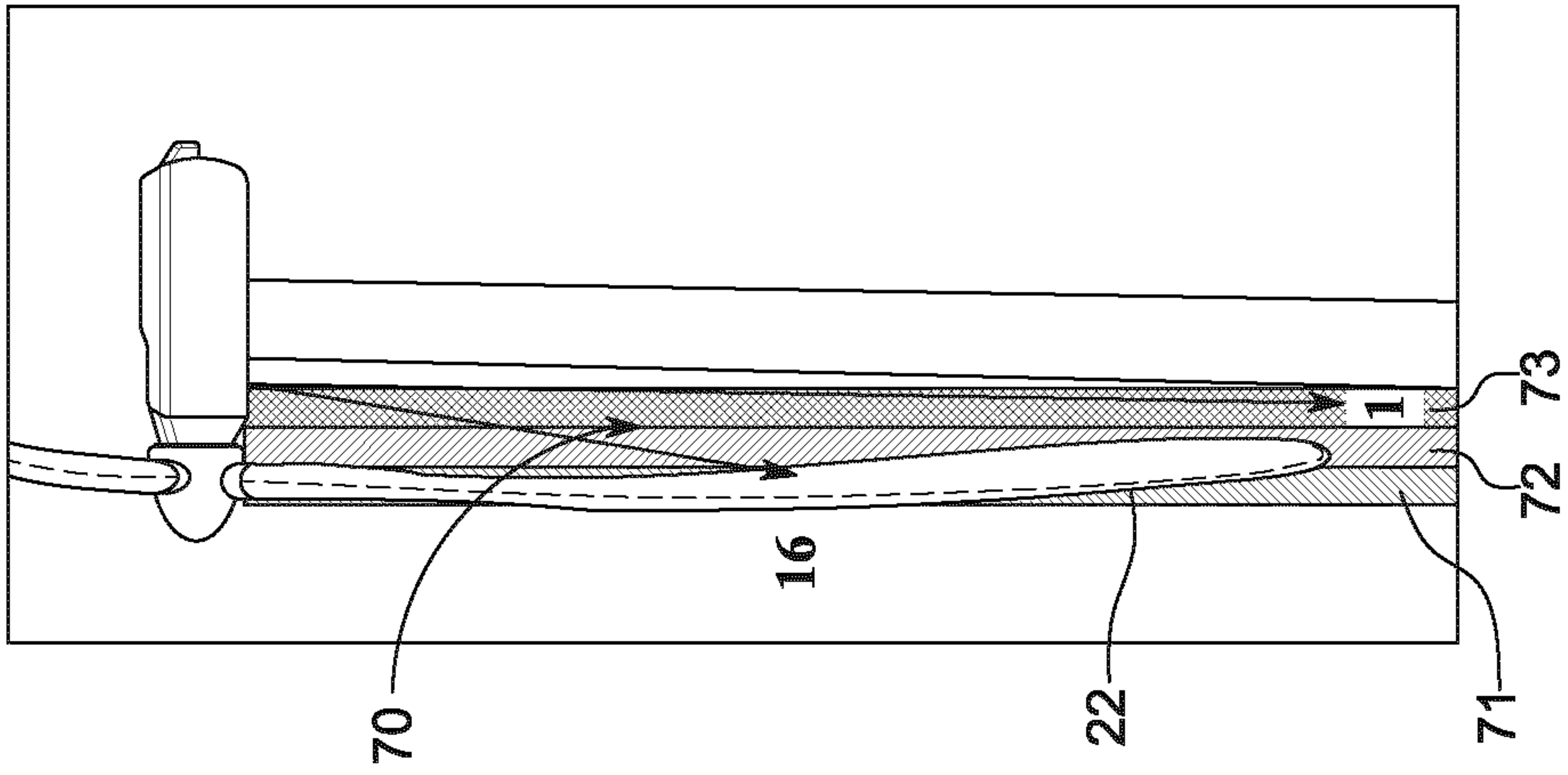

FIG. 4B

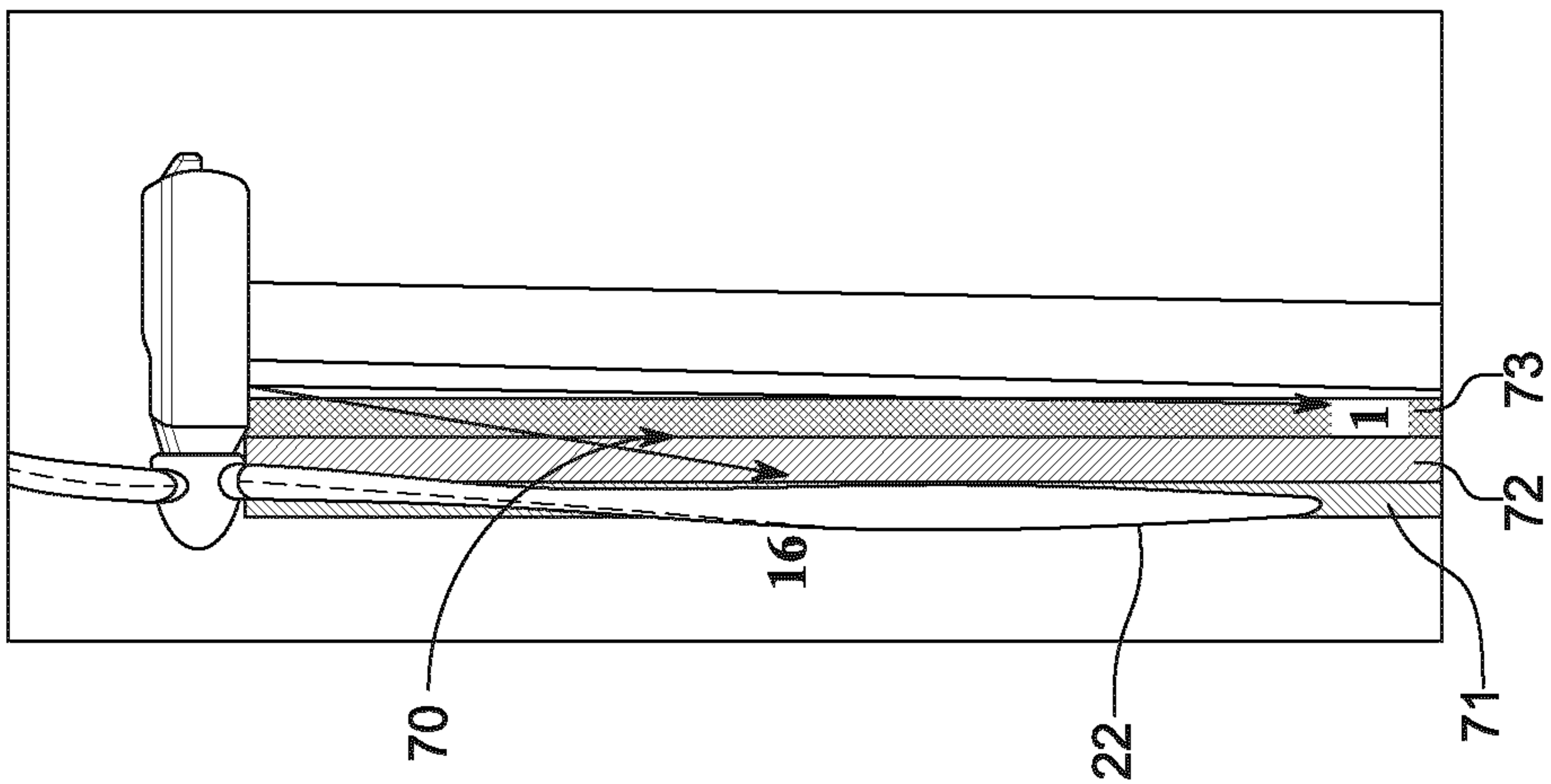

FIG. 4A

5/7

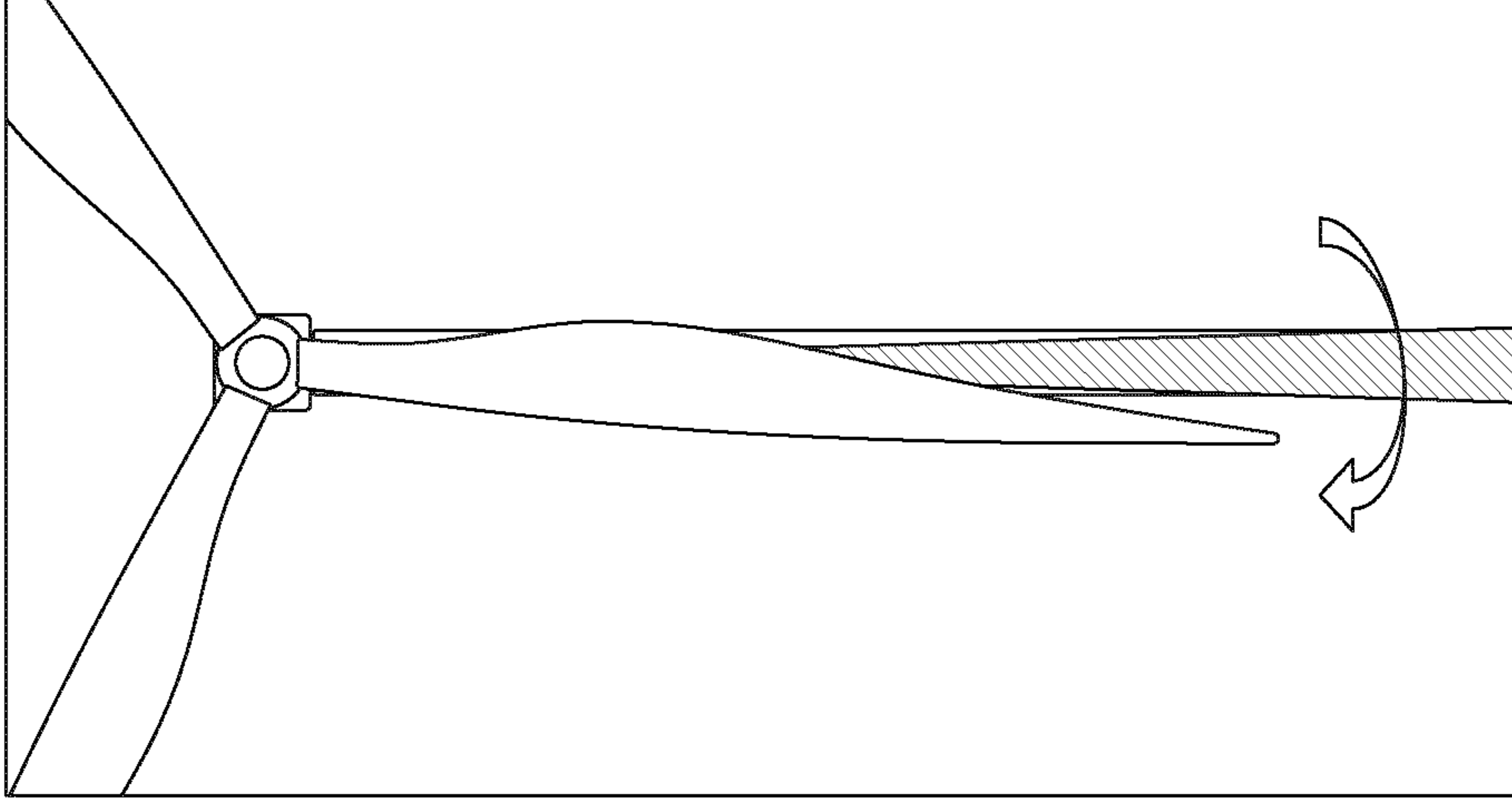

FIG. 5C

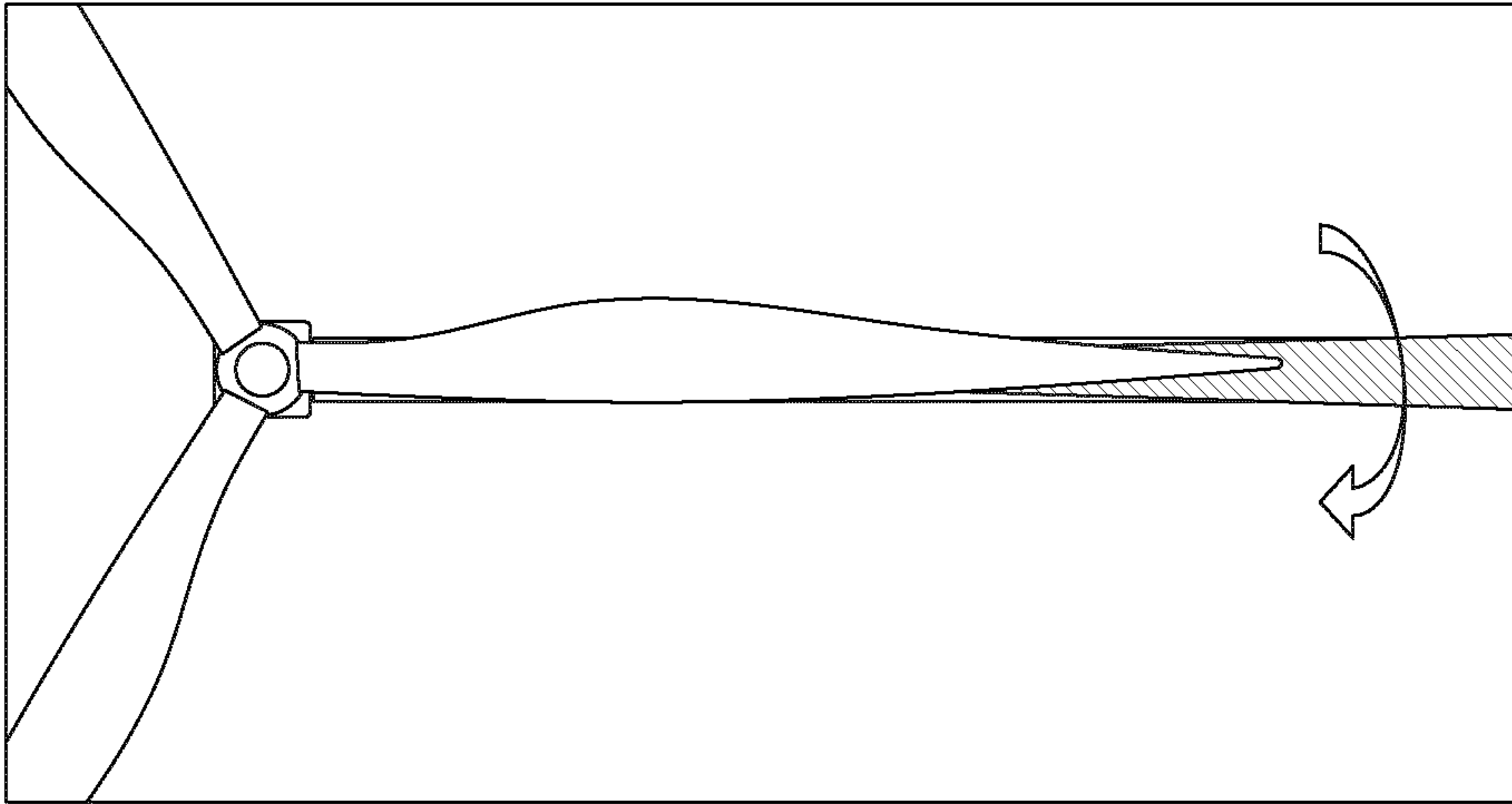

FIG. 5B

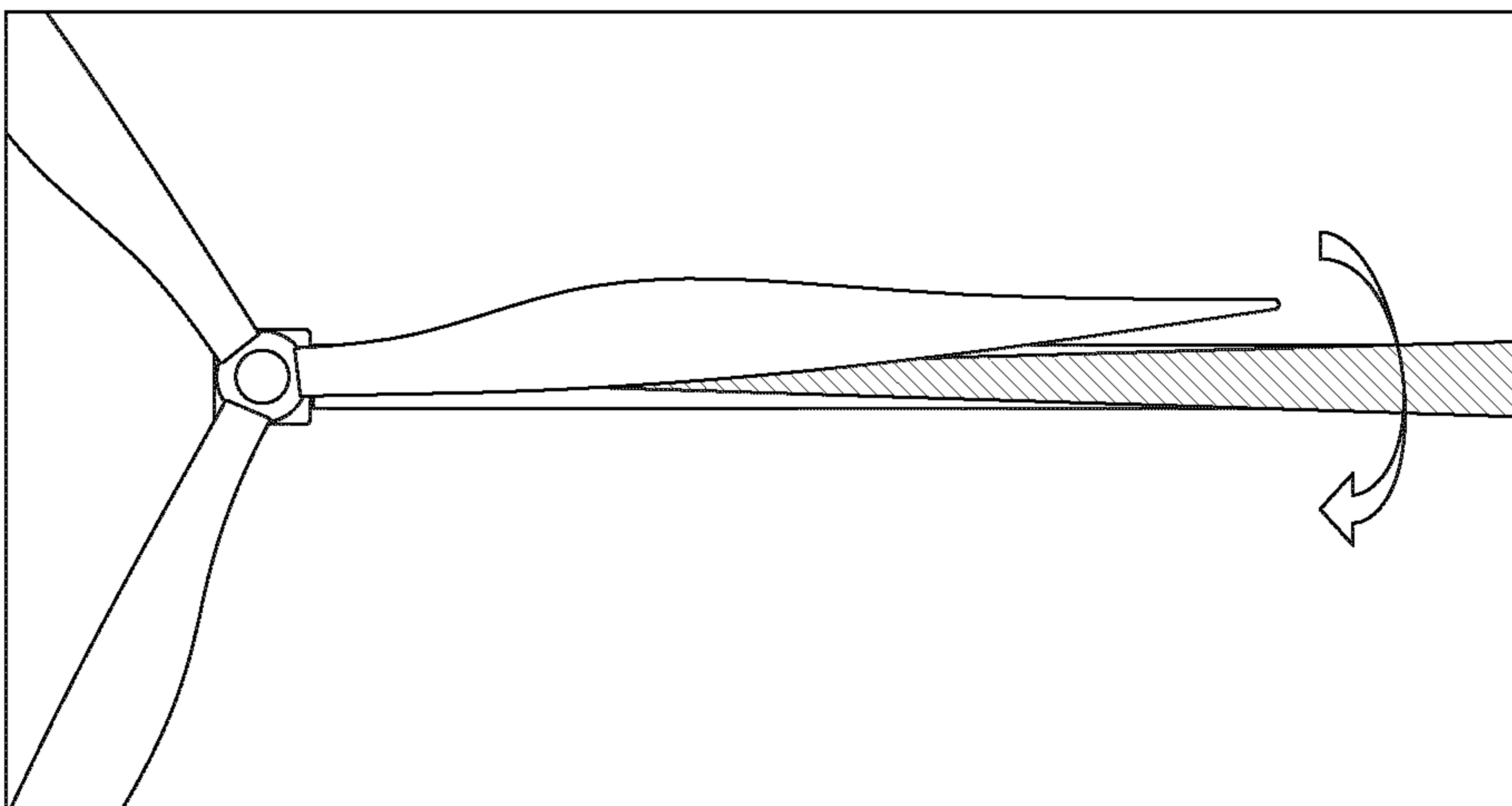

FIG. 5A

6/7

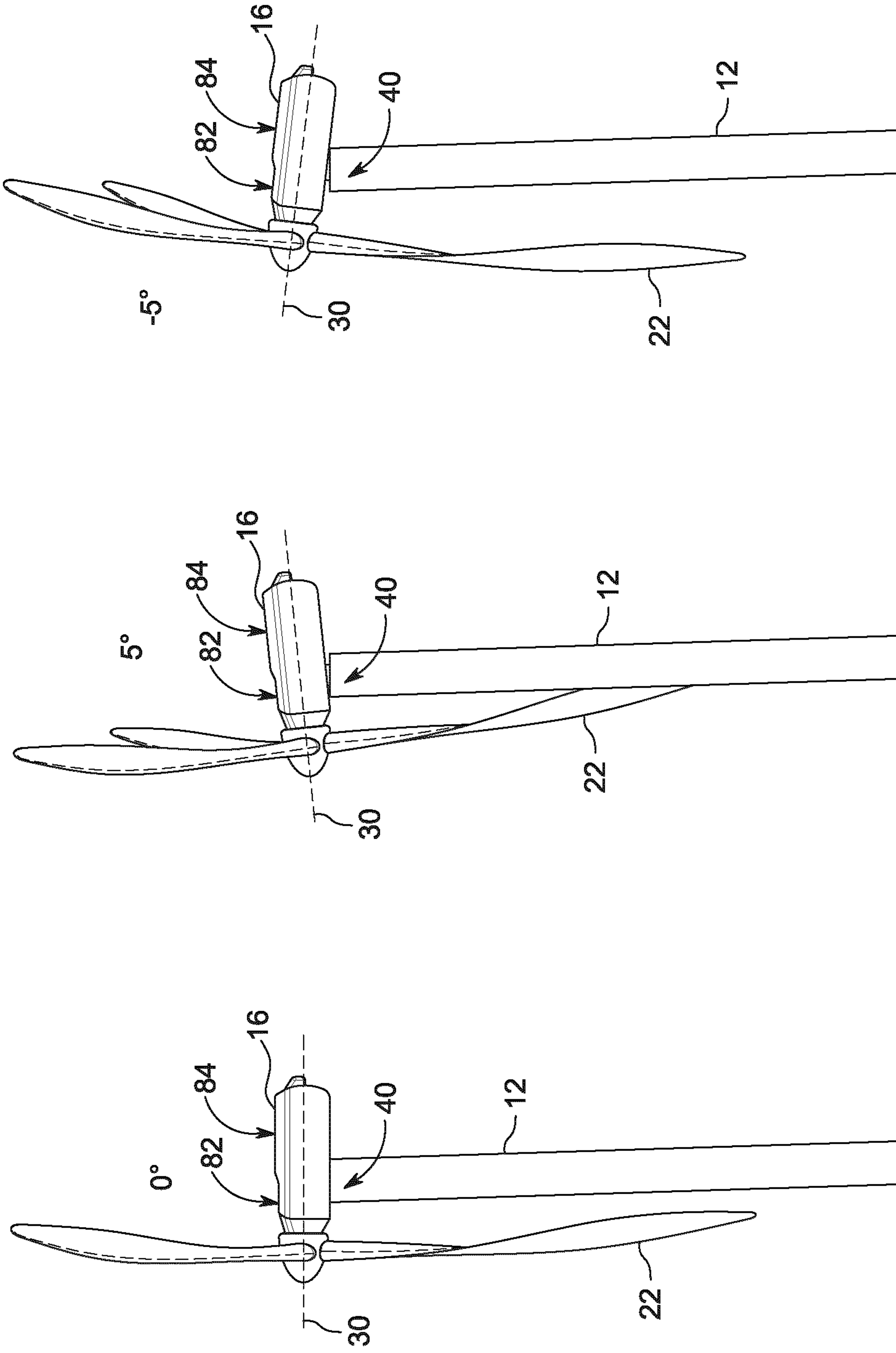

FIG. 6A

FIG. 6B

FIG. 6C



7/7

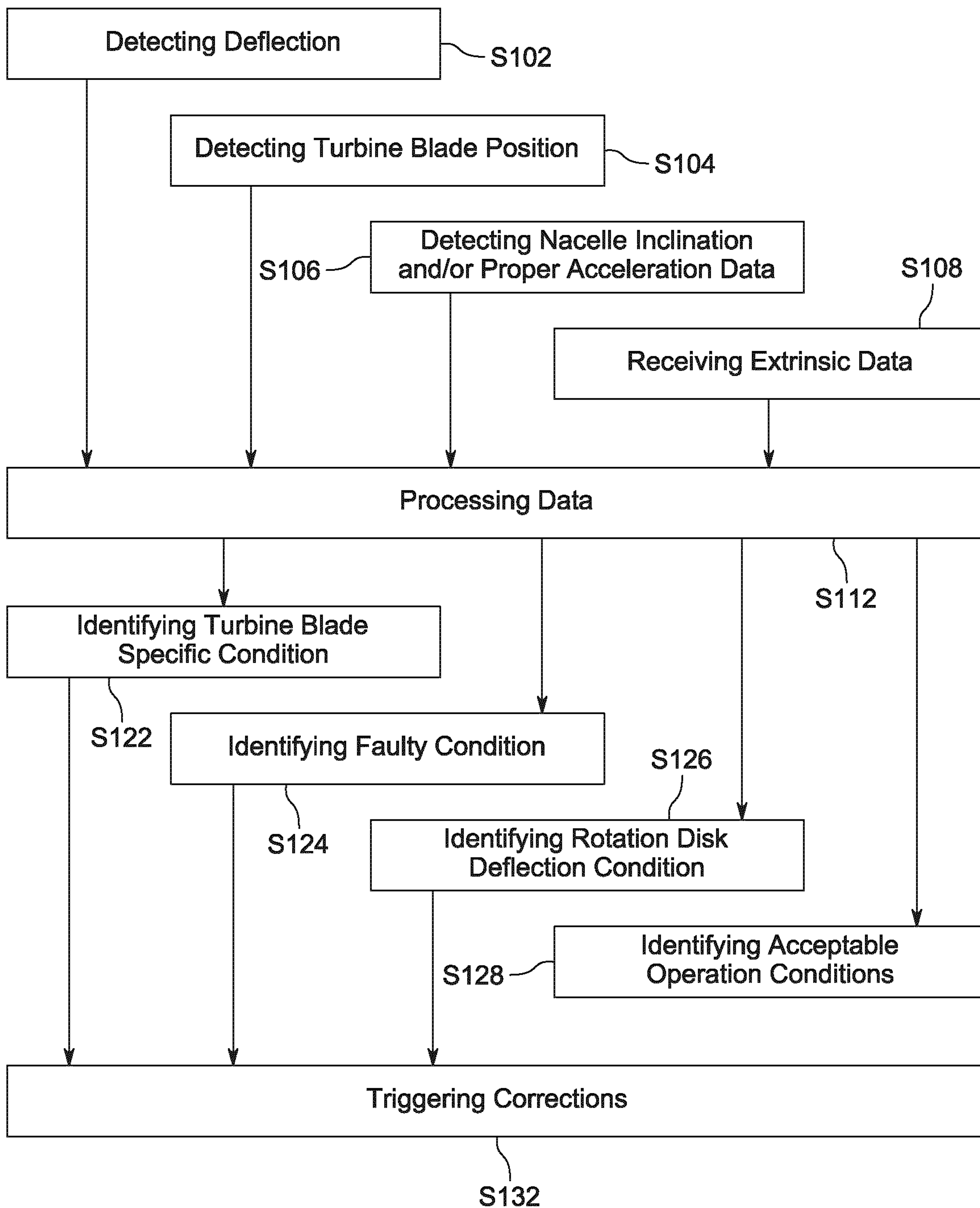

FIG. 7

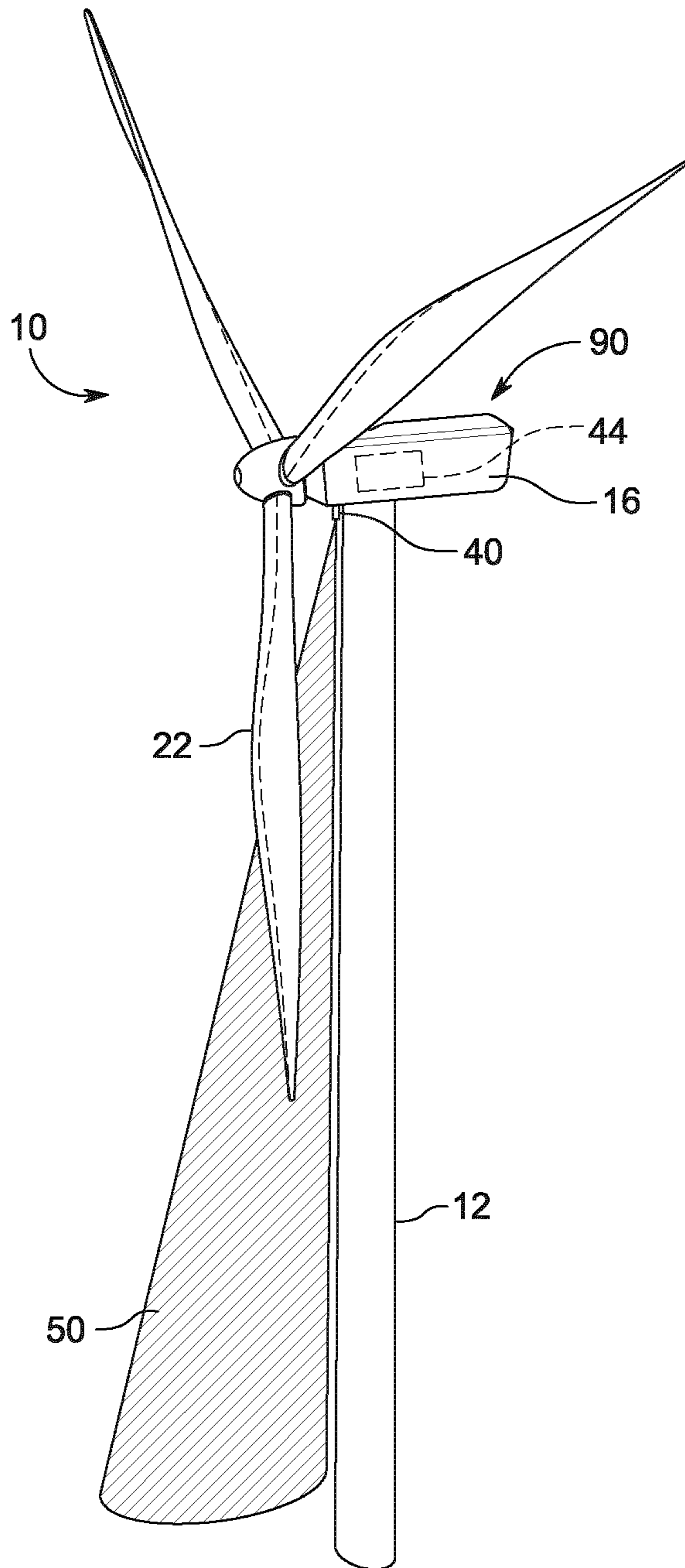

FIG. 2